

Full Size Site Plans

are available for viewing at the

**Zoning Board of Appeals**

Office located at

**308 Gardnertown Road**

Newburgh, NY

845-566-4901

N/F  
CURTIS  
L11676 P. 207  
TAX NO. 43 - 3 - 30  
(MUNICIPAL WATER & PRIVATE SEPTIC)

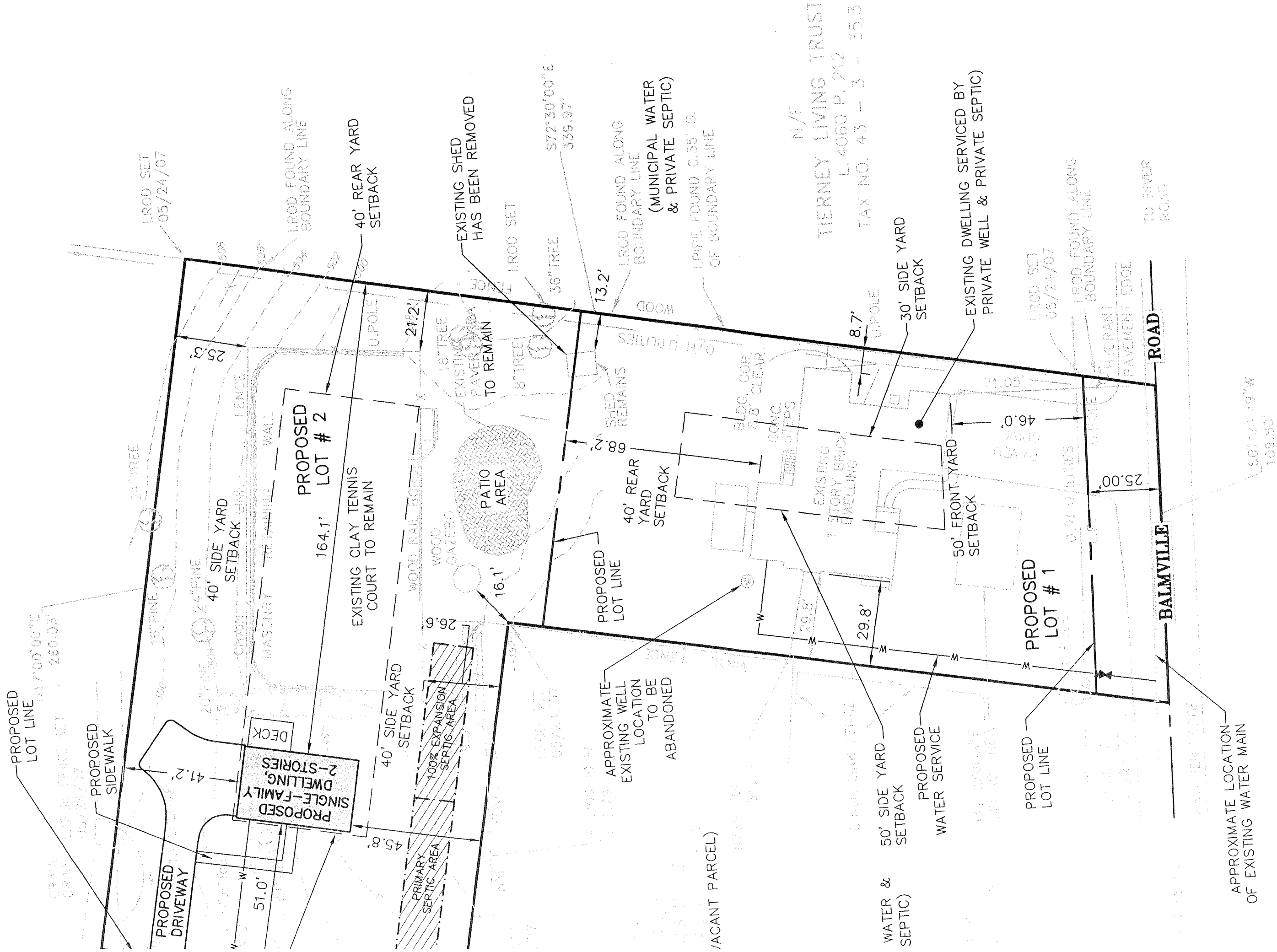

N/F  
TIERNEY LIVING TRUST  
L. 4060 P. 212  
TAX NO. 43 - 3 - 35.3

APPROXIMATE LOCATION  
OF EXISTING WATER MAIN

POWELTON  
COUNTRY CLUB

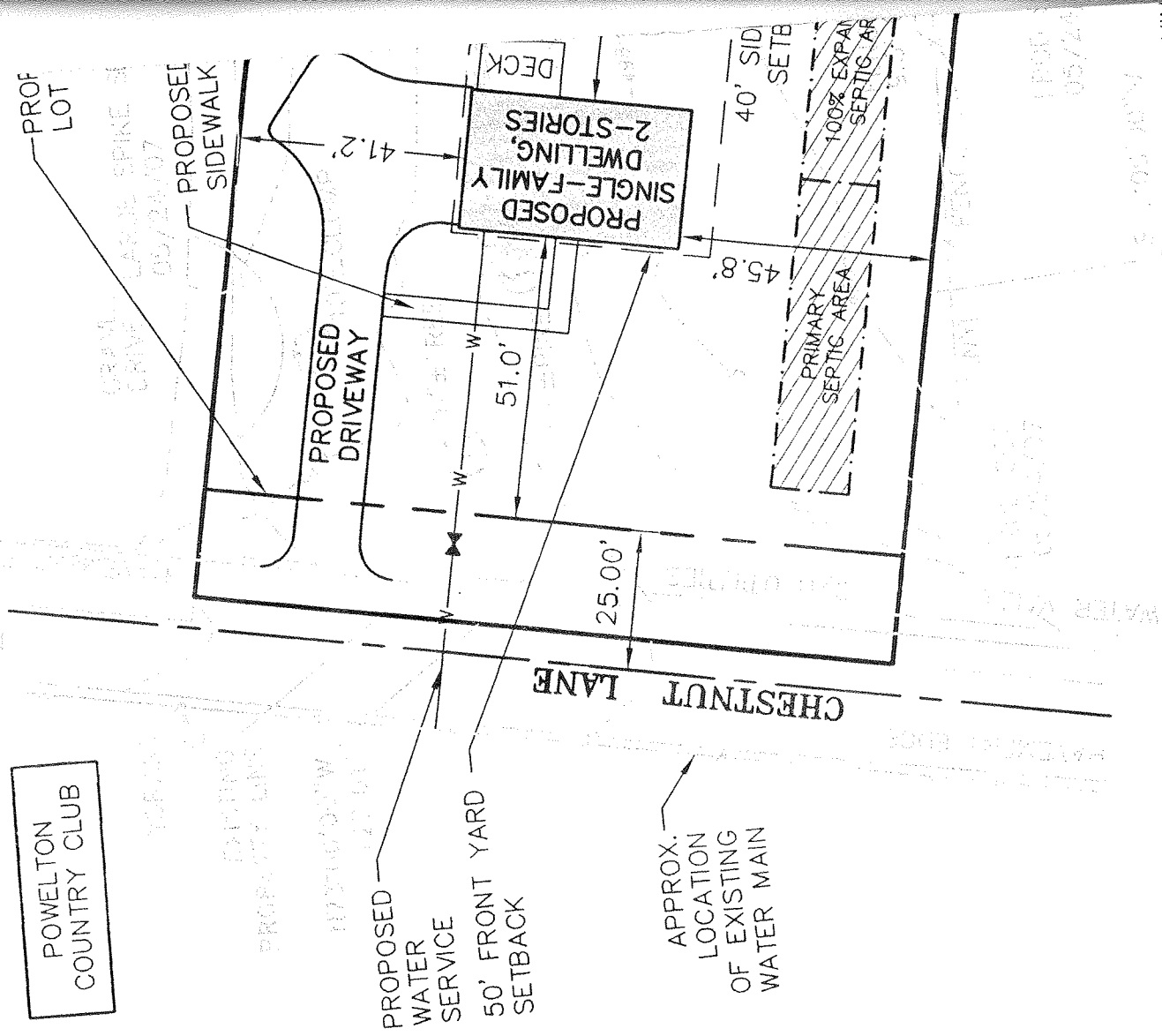

PROPOSED  
WATER  
SERVICE  
50' FRONT YARD  
SETBACK

APPROX.  
LOCATION  
OF EXISTING  
WATER MAIN

CHESTNUT LANE

PROPOSED  
SINGLE-FAMILY  
DWELLING,  
2-STORIES

PRIMARY  
SEPTIC AREA

40' SID  
SETB

(VACANT PARCEL)

(MUNICIPAL WATER &  
PRIVATE SEPTIC)

50' SIDE YARD  
SETBACK

PROPOSED  
WATER SERVICE

PROPOSED  
LOT LINE

APPROXIMATE LOCATION-  
OF EXISTING WATER MAIN

## BULK TABLES

ZONE: R-1 RESIDENTIAL DISTRICT  
 PERMITTED USE: SINGLE FAMILY DWELLINGS, NOT TO EXCEED 1 DWELLING UNIT PER LOT  
 PERMITTED ACCESSORY USE: TENNIS COURT (PROPOSED LOT #2)

### LOT #1

	REQUIRED	PROVIDED	REMARKS
<b>MINIMUM:</b>			
LOT AREA	40,000 SQ. FT.	±20,174.9 SQ. FT.	VARIANCE REQ'D
LOT WIDTH	150 FT	108.8 FT	VARIANCE REQ'D
LOT DEPTH	150 FT	184.2 FT	OK
FRONT YARD SETBACK	50 FT	46.0 FT	VARIANCE REQ'D
REAR YARD SETBACK	40 FT	68.2 FT	OK
1 SIDEYARD SETBACK	30 FT	8.7 FT	VARIANCE REQ'D
BOTH SIDEYARD SETBACK	80 FT	38.5 FT	VARIANCE REQ'D
HABITABLE FLOOR AREA PER UNIT	1,500 SQ. FT.	>1,500 SQ. FT.	OK
<b>MAXIMUM:</b>			
LOT BUILDING COVERAGE	10%	16.8%	VARIANCE REQ'D
BUILDING HEIGHT	35 FT	<35'	OK
LOT SURFACE COVERAGE	20%	28%	VARIANCE REQ'D

### LOT #2

	REQUIRED	PROVIDED	REMARKS
<b>MINIMUM:</b>			
LOT AREA	40,000 SQ. FT.	±31,811.1 SQ. FT.	VARIANCE REQ'D
LOT WIDTH	150 FT	127.0 FT	VARIANCE REQ'D
LOT DEPTH	150 FT	240.1 FT	OK
FRONT YARD SETBACK	50 FT	51.0 FT	OK
REAR YARD SETBACK	40 FT	164.1 FT	OK
1 SIDEYARD SETBACK	30 FT	41.2 FT	OK
BOTH SIDEYARD SETBACK	80 FT	87.0 FT	OK
HABITABLE FLOOR AREA PER UNIT	1,500 SQ. FT.	>1,500 SQ. FT.	OK
ACCESSORY USE SETBACK (TENNIS COURT)	15 FT FROM ANY LOT LINE	21.2 FT	OK
<b>MAXIMUM:</b>			
LOT BUILDING COVERAGE	10%	3.1%	OK
BUILDING HEIGHT	35 FT	<35'	OK
LOT SURFACE COVERAGE	20%	32%	VARIANCE REQ'D

REV.	DATE	DRAWN BY	DESCRIPTION
2	8/10/15	JAP	REVISED PER COMMENT FROM THE ZBA
1	8/8/15	JAP	REVISED FOR ZBA SUBMISSION

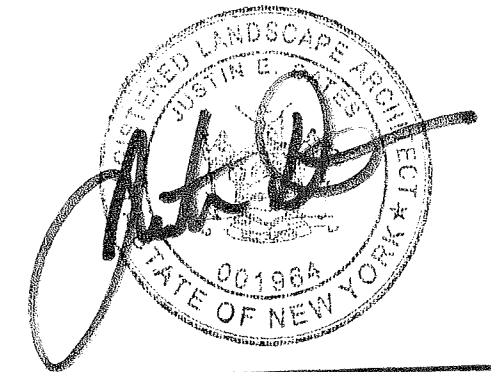

**JUSTIN E. DATES**  
 N.Y. REGISTERED LANDSCAPE ARCHITECT  
 LIC. NO. 001964



Consulting, Municipal & Environmental Engineers  
 Planners ■ Surveyors ■ Landscape Architects  
 State of N.Y. Certificate of Authorization: 0000172

New Jersey New York Pennsylvania Virginia  
 Customer Loyalty through Client Satisfaction

COPYRIGHT ©2012, MASER CONSULTING P.A.  
 ALL RIGHTS RESERVED

THIS DRAWING AND ALL THE INFORMATION CONTAINED HEREIN IS AUTHORIZED FOR USE ONLY BY THE PARTY FOR WHOM THE WORK WAS CONTRACTED OR TO WHOM IT IS CERTIFIED. THIS DRAWING MAY NOT BE COPIED, REUSED, DISCLOSED, DISTRIBUTED OR RELIED UPON FOR ANY OTHER PURPOSE WITHOUT THE EXPRESS WRITTEN CONSENT OF MASER CONSULTING, P.A.

#### NEWBURGH OFFICE

1607 Route 300  
 Suite 101  
 Newburgh, NY 12550  
 Phone: 845.564.4995  
 Fax: 845.564.0278  
 email: solutions @ maserconsulting.com

SKETCH  
**SKETCH SUBDIVISION PLAN**  
 FOR  
**PETER POLHAMUS**  
 TAX LOT 43-3-34.2

TOWN OF NEWBURGH, ORANGE COUNTY, N.Y.

SCALE: 1"=30'	DATE: 11/10/14	DRAWN BY: JJS	CHECKED BY: JED
PROJECT NUMBER: 13001929A		NB00140	

SHEET NUMBER:  
**1 of 2**

N/F  
CURTIS  
L.11676 P. 207  
TAX NO. 43 - 3 - 30  
(MUNICIPAL WATER & PRIVATE SEPTIC)

POWELTON  
COUNTRY CLUB

PROPOSED  
WATER  
SERVICE  
PROPOSED  
1,000 GAL.  
SEPTIC TANK

APPROX.  
LOCATION  
OF EXISTING  
WATER MAIN

CHESTNUT  
LANE

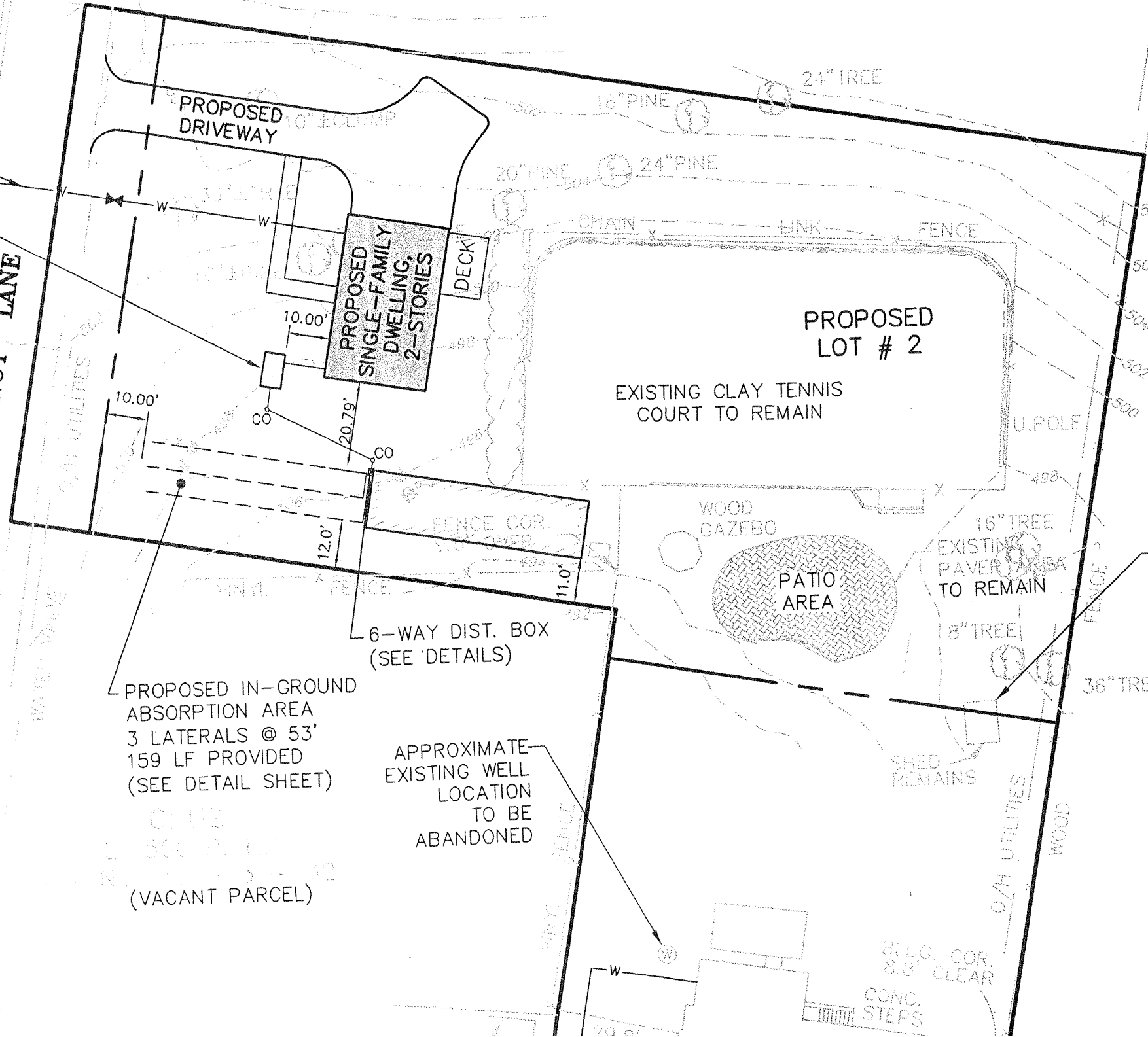

PROPOSED IN-GROUND  
ABSORPTION AREA  
3 LATERALS @ 53'  
159 LF PROVIDED  
(SEE DETAIL SHEET)  
(VACANT PARCEL)

APPROXIMATE  
EXISTING WELL  
LOCATION  
TO BE  
ABANDONED

EXISTING SHED  
HAS BEEN REMOVED

(MUNICIPAL WATER  
& PRIVATE SEPTIC)

(MUNICIPAL WATER &  
PRIVATE SEPTIC)  
N/F  
CRUZ  
L. 5508 P. 113  
TAX NO. 43 - 3 - 35.3

N/F  
TIERNEY LIVING TRUST  
L. 4060 P. 212  
TAX NO. 43 - 3 - 35.3

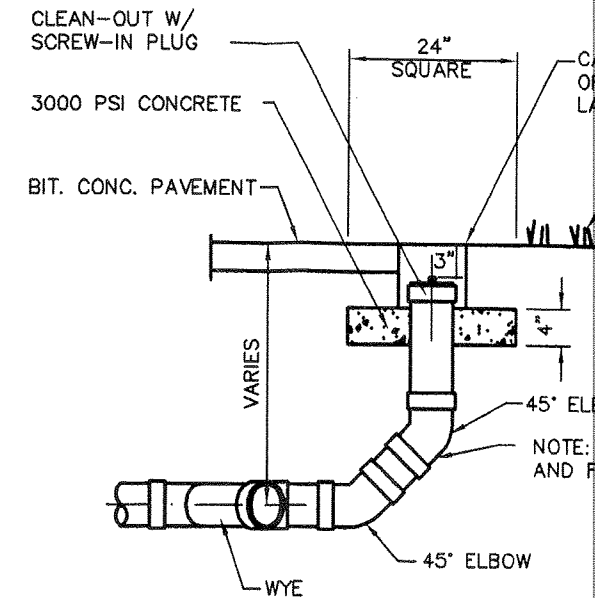
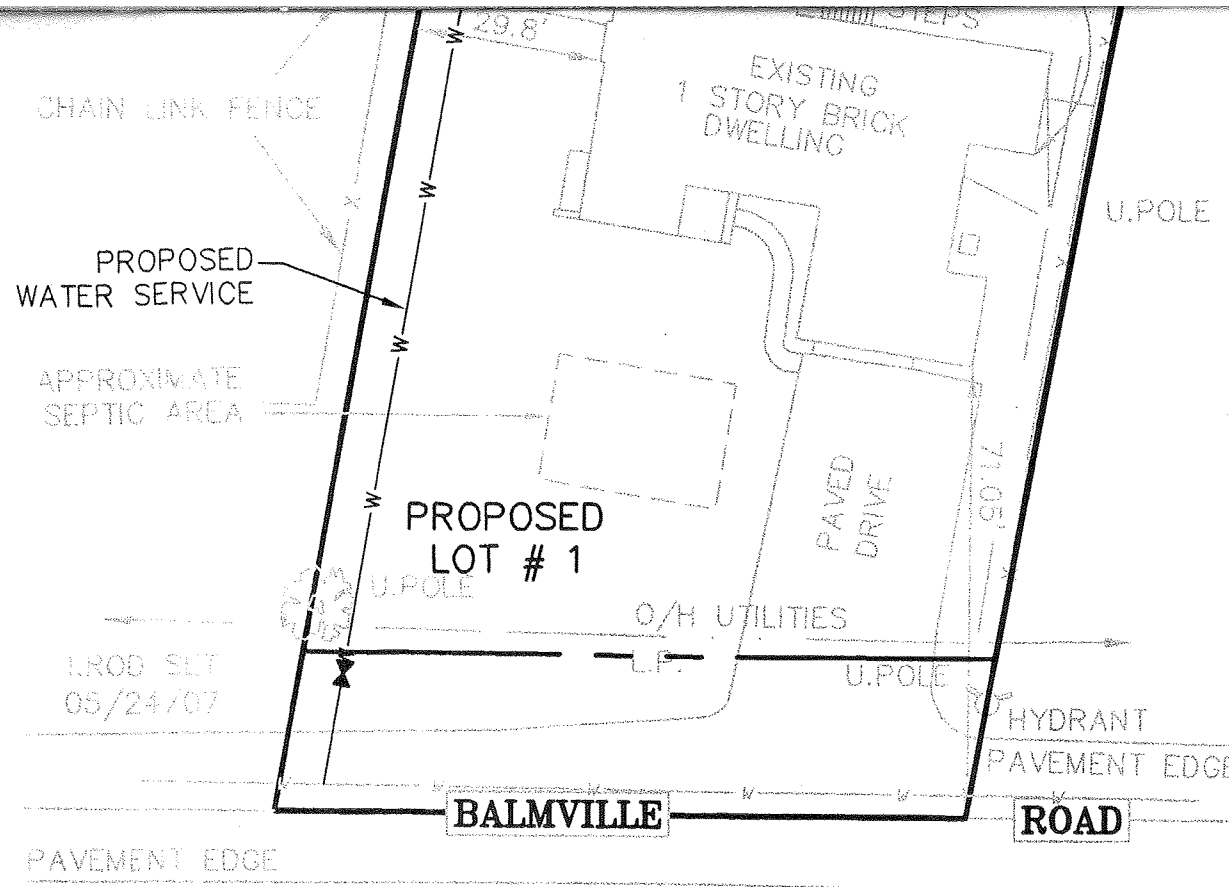

**SANITARY SEWER CLEANOUT**  
N.T.S.

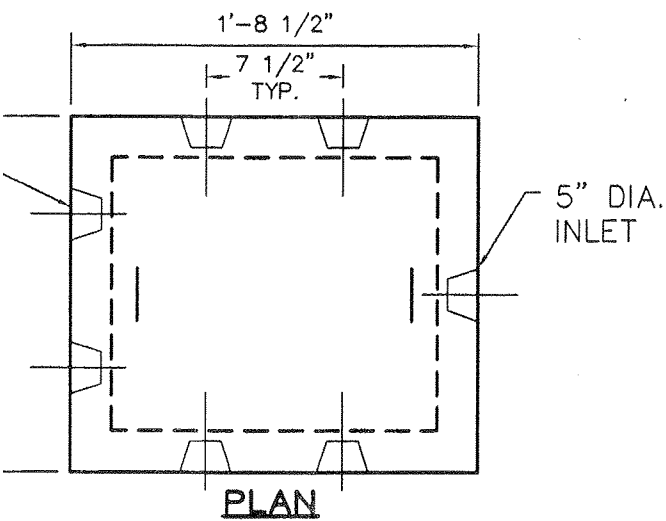

- NOTE:**
1. INLET AND OUTLETS ARE KNOCKOUTS
  2. WEIGHT BOX-256 LBS, TOP-56 LBS
  3. CONCRETE TO TEST 4,000 PSI AT 28 DAYS, STEEL REINFORCEMENT ASTM-A-615-68, GRADE 40, 12" MAX. COVER.
  4. BEDDING TO BE 12 INCHES MINIMUM OF CLEAN SAND, PEA GRAVEL OR AGGREGATE (3/4" TO 1 1/2").
  5. MAXIMUM COVER OVER DISTRIBUTION BOX TO BE 12 INCHES.
  6. ALL USED OUTLETS TO BE AT SAME ELEVATION OR SPEED LEVELERS SHALL BE USED.

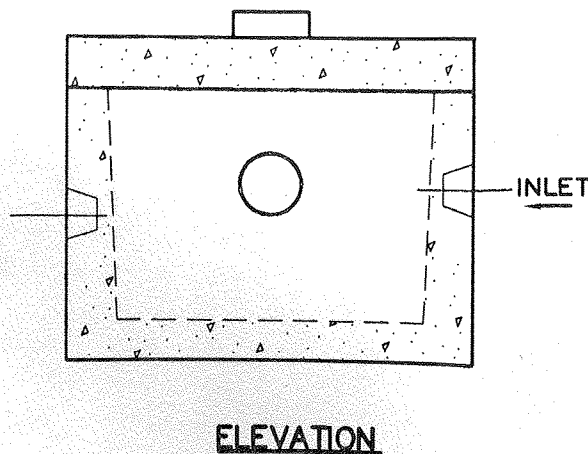
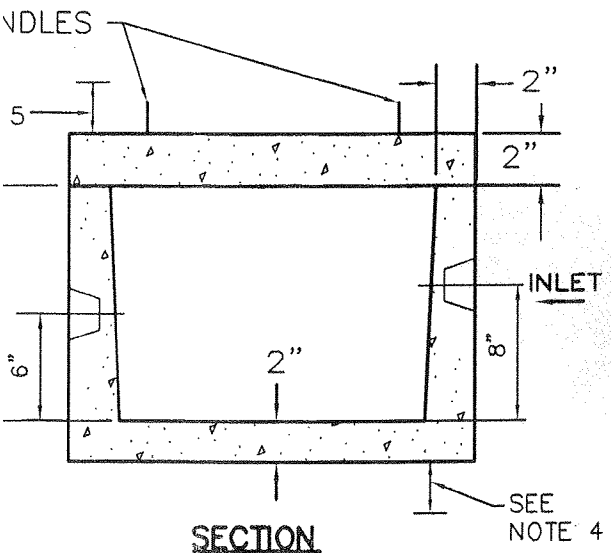

**6 WAY DISTRIBUTION BOX DETAIL**

N.T.S.

**SEPTIC SYSTEM DESIGN TABLE**

TESTING CONDUCTED BY MASER CONSULTING ON 04/24/15

LOT #	STABILIZED PERC RATE (Min/Inch)	REQUIRED LENGTH OF ABSORPTION TRENCH (PRIMARY)	DEEP TEST INFORMATION (HOLE 1)	DEEP TEST INFORMATION (HOLE 2)	TYPE OF SEPTIC SYSTEM (PRIMARY)
		2 BEDROOM			
1			1-1	1-2	
DESIGN	16-20 MIN.	158*	0-6" TOPSOIL 6-15" DARK LOAMY SAND W/ COBBLES THROUGHOUT	0-6" TOPSOIL 6-18" DARK SANDY LOAM W/ SMALL COBBLES THROUGHOUT	IN GROUND SYSTEM
1-1	(24") 4 MIN.		15-72" BROWN LOAMY SAND W/ COBBLES	18-72" SANDY CLAY LOAM W/ COBBLES	
1-2	(24") 17 MIN.				
			NO MOTTLING NO GROUNDWATER NO BEDROCK	NO MOTTLING NO WATER NO BEDROCK	

REQUIRED LENGTHS OF ABSORPTION TRENCH SHOWN ON PLAN BASED ON DESIGN PERCOLATION RATE  
DESIGN = PERCOLATION RATE USED FOR DESIGN  
\* = DENOTES LENGTH REQUIRED FOR CONVENTIONAL ABSORPTION SYSTEM