

**JOSEPH P. PEDI**  
**Town Clerk**  
**1496 Route 300**  
**Town of Newburgh, New York 12550**  
**Telephone 845-564-4554**

**TOWN BOARD PUBLIC MEETING AGENDA**  
**Tuesday, October 15, 2019**  
**7:00 p.m.**

1. ROLL CALL
2. PLEDGE OF ALLEGIANCE TO THE FLAG
3. MOMENT OF SILENCE
4. CHANGES TO AGENDA
5. SWEARING IN OF TWO POLICE OFFICERS
6. APPROVAL OF AUDIT
7. PUBLIC HEARING (7:00 p.m.): Preliminary Town Budget for Year 2020
8. PUBLIC HEARING (7:30 p.m.): Chadwick Lake Filter Plant Improvements
9. DEPARTMENT HEAD REPORTS
10. TOWN SUPERVISOR: Halloween Proclamation
11. JUSTICE COURT (Town Justice Richard Clarino)
  - A. Confirmation of Appointment for Chief Court Clerk
  - B. Approval of Salary for Chief Court Clerk
12. ANIMAL CONTROL: T-94 Withdrawal
13. LABOR ATTORNEY: Approval of Agreement
14. HIGHWAY DEPARTMENT: Fall Leaf and Brush Pick Up
15. WATER DEPARTMENT: Budget Transfer
16. FLEET DEPARTMENT: Budget Transfer
17. EMPLOYEE ASSISTANCE PROGRAM: Approval of Contract
18. BUILDING AND GROUNDS: Award of Security System Quote for  
21 Hudson Valley Plaza
19. RECEIVER OF TAXES:
  - A. 2019 Chargebacks
  - B. 2019 Unpaid Sewer Bond Relevy
20. ACCOUNTING: Justice Court Unclaimed Bail
21. ANNOUNCEMENTS
22. PUBLIC COMMENTS
23. ADJOURNMENT

GJP:jpp  
Second Revision – October 11, 2019; 9:00 am



Rider Weiner & Frankel P.C.  
ATTORNEYS & COUNSELORS AT LAW

MEMORANDUM

TO: HON. GILBERT J. PIAQUADIO, SUPERVISOR  
TOWN BOARD MEMBERS

FROM: MARK C. TAYLOR, ATTORNEY FOR THE TOWN

RE: CHADWICK LAKE RESERVOIR AND WATER  
FILTRATION PLANT IMPROVEMENTS PROJECT;  
OUR FILE NO. 800.1(B)(3)(2019), 801.152

DATE: OCTOBER 10, 2019

P: 845.562.9100  
F: 845.562.9126  
655 Little Britain Road  
New Windsor, NY 12553  
P.O. Box 2280  
Newburgh, NY 12550

Enclosed for the Town Board's consideration are the following draft Resolutions and draft Order:

**ATTORNEYS**  
David L. Rider  
Charles E. Frankel  
Michael J. Matsler  
Mark C. Taylor  
Deborah Weisman-Estis  
M. Justin Rider  
Donna M. Badura  
Amber L. Camio

*M. J. Rider*  
(1906-1968)  
*Elliott M. Weiner*  
(1915-1990)

**COUNSEL**  
Stephen P. Duggan, III  
John K. McGuirk  
(1942-2018)

**OF COUNSEL**  
Craig F. Simon  
Irene V. Villacci

1. A RESOLUTION OF SEQR DETERMINATION BY THE TOWN BOARD OF THE TOWN OF NEWBURGH AS THE LEAD AGENCY FOR THE PROPOSED CHADWICK LAKE WATER TREATMENT PLANT IMPROVEMENT PROJECT; A TYPE I ACTION SUBJECT TO COORDINATED REVIEW;
2. PUBLIC INTEREST ORDER IN THE MATTER OF THE INCREASE AND IMPROVEMENT OF THE FACILITIES OF THE CONSOLIDATED WATER DISTRICT IN THE TOWN OF NEWBURGH, ORANGE COUNTY, NEW YORK; AND
3. RESOLUTION OF TOWN BOARD APPROVING AND AUTHORIZING SUPERVISOR TO EXECUTE INTER-GOVERNMENTAL AGREEMENT BY AND BETWEEN THE TOWN OF NEWBURGH AND THE CITY OF NEW YORK FOR THE CONSTRUCTION OF CERTAIN IMPROVEMENTS TO CHADWICK LAKE RESERVIOR AND WATER TREATMENT FILTRATION PLANT

We have previously forwarded copies of the draft Full Environmental Assessment Form Part 1 and Part 2 and a copy of the Engineering Evaluation of Long Term Use & Economic Viability of the Chadwick Lake Reservoir & Filter

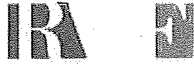

CHADWICK LAKE RESERVOIR AND WATER TREATMENT  
PLANT IMPROVEMENT PROJECT  
PAGE 2

Plant, Town of Newburgh, New York certified by Scott W. Davis, P.E. of HDR Inc. which Town Engineer James Osborne advises comprises the map, plan and report needed for the Town Law Section 202-b public hearing.

Additionally enclosed with this memo is a copy of the proposed Agreement with the City of New York Department of Environmental Protection pertaining to the improvement project. We will forward the proposed Negative Declaration under separate cover.

Should you have any questions or concerns, please do not hesitate to contact me.

cc: Town Clerk Joseph P. Pedi (via e-mail)  
James Osborne, Town Engineer (via e-mail)  
Ronald Clum, Town Accountant (via e-mail)

At a meeting of the Town Board of the Town of Newburgh held at the Town Hall, 1496 Route 300, in the Town of Newburgh, Orange County, New York, on the 23rd day of October, 2019 at 7:00 o'clock p.m.

PRESENT:

Gilbert J. Piaquadio, Supervisor

Elizabeth J. Greene, Councilwoman

Paul I. Ruggiero, Councilman

James E. Presutti, Councilman

Scott M. Manley, Councilman

A RESOLUTION OF SEQR DETERMINATION BY THE TOWN BOARD OF THE TOWN OF NEWBURGH AS LEAD AGENCY FOR THE PROPOSED CHADWICK LAKE WATER TREATMENT PLANT IMPROVEMENT PROJECT, A TYPE I ACTION SUBJECT TO COORDINATED REVIEW

Councilman/woman \_\_\_\_\_ presented the following resolution which was seconded by Councilman/woman \_\_\_\_\_.

**WHEREAS**, the Town Board of the Town of Newburgh has proposed to undertake the project generally described as the Chadwick Lake Water Treatment Plant Improvement Project, which encompasses the planning, design, engineering, reconstruction and construction of improvements to the Chadwick Lake Reservoir and Water Treatment Plant consisting of installing a water quality monitor in Chadwick Lake, installing a powder activated carbon (PAC) feed system, installing the necessary piping, mechanical equipment, tankage and electrical/process control modifications to connect to a trailer-mounted membrane filtration unit, adding a third solids handling tank and installing floating decanters in the solids handling tanks to ensure a minimum supply of 2.0 million gallons per day of water during the planned shutdown of the New York City Delaware Aqueduct, and operational and maintenance undertakings including continued dosing of algaecide in Chadwick Lake, bench testing of systems, installing a temporary trailer-mounted membrane filtration unit and second shift operation will be undertaken in conjunction with the project, all in connection with the treatment of the Town of Newburgh Consolidated Water District's Chadwick Lake Reservoir water supply and within the Chadwick Lake Reservoir Critical Environmental Area in the Town of Newburgh, New York (herein called the "Action"); and

**WHEREAS**, the Action additionally encompasses the approval of an Agreement with the New York City Department of Environmental Protection to fund the project; and



WHEREAS, the Town Board of the Town of Newburgh has caused a full Environmental Assessment Form (the "EAF") to be prepared for the proposed Action; and

WHEREAS, the Town Board pursuant to Article 8 of the Environmental Conservation Law ("SEQRA"), Part 617 of the General Regulations adopted pursuant thereto ("Part 617") and Chapter 100 entitled "Environmental Quality Review" of the Town of Newburgh Municipal Code, has determined that the Action is subject to SEQRA and is a Type I Action under SEQRA, Part 617 and Chapter 100, as it is located in the Chadwick Lake Critical Environmental Area; and

WHEREAS, the Town Board has determined that the Action does not involve a federal agency; and

WHEREAS, the Town Board has determined that the Action is not located in an agricultural district; and

WHEREAS, the Town Board using all due diligence has identified the following agencies as involved agencies for the Action:

New York City Department of Environmental Protection

New York State Department of Health

Orange County Department of Health

New York State Department of Environmental Conservation

and;

WHEREAS, the Town Board on January 28, 2019 adopted a resolution directing that a Lead Agency coordination notice to be circulated among the various involved agencies together with copies of the EAF, and such other information as is appropriate, indicating the Town Board's intent to assume the role of Lead Agency for the Action under SEQRA and Part 617; and

WHEREAS, the identified involved agencies have either agreed that the Town Board shall act as the Lead Agency for the Action or not responded within the thirty (30) calendar day time frame established under SEQRA; and

WHEREAS, the Town Board pursuant to Article 8 of the Environmental Conservation Law ("SEQRA"), Part 617 of the General Regulations adopted pursuant thereto ("Part 617") and Chapter 100 entitled "Environmental Quality Review" of the Town of Newburgh Municipal Code, hereby declares itself Lead Agency for this Type I Action for the purpose of conducting a coordinated review.

NOW THEREFORE BE IT RESOLVED, that the Town Board, as Lead Agency, hereby determines that said Action will not have a significant effect on the environment and, accordingly,

does issue a Negative Declaration; and

BE IT FURTHER RESOLVED, that the Town Board accordingly determines that an Environmental Impact Statement will not be prepared; and

BE IT FURTHER RESOLVED, that the Town Board hereby authorizes the Supervisor to execute, file and cause to be published the Environmental Assessment Form Determination of Significance and Negative Declaration heretofore prepared for this determination with such further amendment and modification as may be required to elaborate the Lead Agency's determination herein, in accordance with the applicable provisions of law, and all other appropriate notices and documents to effectuate these resolutions in accordance with the applicable provisions of law.

The foregoing resolution was duly put to a vote on roll call which resulted as follows:

<u>Elizabeth J. Greene, Councilwoman</u>	<u>voting</u>
<u>Paul I. Ruggiero, Councilman</u>	<u>voting</u>
<u>James E. Presutti, Councilman</u>	<u>voting</u>
<u>Scott M. Manley, Councilman</u>	<u>voting</u>
<u>Gilbert J. Piaquadio, Supervisor</u>	<u>voting</u>

The resolution was thereupon declared duly adopted

At a regular meeting of the Town Board of the Town of Newburgh, Orange County, New York, held at the Town Hall, in Newburgh, New York on October 15, 2019, at 7:00 o'clock P.M., Prevailing Time.

PRESENT:

Gilbert J. Piaquadio  
Supervisor

Elizabeth J. Greene  
Councilwoman

Paul I. Ruggiero  
Councilman

James E. Presutti  
Councilman

Scott M. Manley  
Councilman

Councilman/woman \_\_\_\_\_ presented the following order which was seconded by Councilman/woman \_\_\_\_\_.

In the Matter of The Increase and Improvement of the Facilities of the Consolidated Water District: in the Town of Newburgh, Orange County, New York	PUBLIC INTEREST ORDER
---	-----------------------------

WHEREAS, the Town Board of the Town of Newburgh, Orange County, New York, has caused to be prepared a map, plan and report, including an estimate of cost, pursuant to Section 202-b of the Town Law, relating to the increase and improvement of the facilities of the Consolidated Water District, in the Town of Newburgh, Orange County, New York (the "Consolidated Water District:"); being the planning, design, engineering, reconstruction and construction of improvements to the Chadwick Lake Reservoir and Water Treatment Plant consisting of installing a water quality monitor in Chadwick Lake, installing a powder activated carbon (PAC) feed system, installing the necessary piping, mechanical equipment, tankage and electrical/process control modifications to connect to a trailer-mounted membrane filtration unit, adding a third solids handling tank and installing floating decanters in the solids handling tanks to ensure a minimum supply of 2.0 million gallons per day of water during the planned

shutdown of the New York City Delaware Aqueduct in 2022 in and for said Town, including the original furnishings, equipment, machinery and apparatus, appurtenances, as well as incidental costs and expenses in connection therewith, at a maximum estimated cost of \$1,823,900; and

WHEREAS, said capital project has been determined to be a Type I Action pursuant to the regulations of the New York State Department of Environmental Conservation promulgated pursuant to the State Environmental Quality Review Act ("SEQRA") and Chapter 100 of the Town of Newburgh Municipal Code, the implementation of which as proposed, will not result in any significant environmental effects; and

WHEREAS, at a meeting of said Town Board duly called and held on the 23rd day of September, 2019, an order was duly adopted by it and entered in the minutes reciting the filing of such map, plan and report including an estimated of cost, the improvement proposed and the maximum aggregate amount proposed to be expended for the improvement, to-wit: the sum of \$1,823,900.00 for the Consolidated Water District, and specifying that said Board would meet to consider the map, plan and report, including an estimate of cost and the increase and improvement of the facilities of the Consolidated Water District and to hear all persons interested in the subject thereof concerning the same at 1496 Route 300 in Newburgh, New York, in said Town on the 15th day of October, 2019 at 7:30 o'clock, p.m., Prevailing Time; and

WHEREAS, the Notice of Public Hearing duly authorized by said order and duly certified by the Town Clerk was duly published and posted as required by law, to-wit: a duly certified copy thereof was published in The Mid Hudson Times, which is hereby designated as an official newspaper of this Town for such purpose on October \_\_, 2019 and in The Sentinel, which is also hereby designated as an official newspaper of this Town for such purpose on October \_\_, 2019, and a copy of such Notice of Public Hearing was posted on October \_\_, 2019, on the signboard maintained by the Town Clerk of the Town of Newburgh pursuant to Section 30, subdivision 6 of the Town Law; and

WHEREAS, a public hearing was duly held at the time and place set forth in said notice, at which all persons desiring to be heard were duly heard.

NOW, THEREFORE, IT IS HEREBY

ORDERED, by the Town Board in the Town of Newburgh, Orange County, New York, as follows:

Section 1. A copy of the Notice of Public Hearing set forth in the Order calling a public hearing as recited in the preambles hereof duly certified by the Town Clerk was duly published and posted as required by law.

Section 2. Upon the evidence given at the aforesaid public hearing, it is hereby found and determined that it is in the public interest to make the increase and improvement of the facilities of the Consolidated Water District, in the Town of Newburgh, Orange County, New York, consisting of the planning, design, engineering, reconstruction and construction of improvements to the Chadwick Lake Reservoir and Water Treatment Plant consisting of installing a water quality monitor in Chadwick Lake, installing a powder activated carbon (PAC) feed system, installing the necessary piping, mechanical equipment, tankage and electrical process control modifications to connect to a trailer-mounted membrane filtration unit, adding a third solids handling tank and installing floating decanters in the solids handling tanks to ensure a minimum supply of 2.0 million gallons per day of water during the planned shutdown of the New York City Delaware Aqueduct in 2022 in and for said Town, including the original furnishings, equipment, machinery and apparatus, appurtenances, as well as incidental costs and expenses in connection therewith, at a maximum estimated cost of \$1,823,900.

Section 3. The Town Engineer is hereby directed to prepare or to cause a licensed professional engineer retained for said purposes to prepare definite plans and specifications and to make a careful estimate of the expense of the aforesaid improvements, and to prepare a proposed contract for the execution of the work.

Section 4. The Town Clerk shall cause a copy of this Order to be filed with the County Clerk of the County of Orange.

Section 5. This Order shall take effect immediately.

The question of the adoption of the foregoing order was duly put to a vote on roll which resulted as follows:

<u>Elizabeth Greene, Councilwoman</u>	<u>voting</u>
<u>Paul I. Ruggiero, Councilman</u>	<u>voting</u>
<u>James E. Presutti, Councilman</u>	<u>voting</u>
<u>Scott M. Manley, Councilman</u>	<u>voting</u>
<u>Gilbert J. Piaquadio, Supervisor</u>	<u>voting</u>

The order was thereupon declared duly adopted.

**CERTIFICATION FORM**

STATE OF NEW YORK            )  
  ) ss.:  
COUNTY OF ORANGE         )

I, the undersigned Clerk of in the Town of Newburgh, Orange County, New York (the "Issuer"), DO HEREBY CERTIFY:

1. That a meeting of the Issuer was duly called, held and conducted on the 15th day of October, 2019.
2. That such meeting was a **special regular** (circle one) meeting.
3. That attached hereto is a proceeding of the Issuer which was duly adopted at such meeting by the Board of the Issuer.
4. That such attachment constitutes a true and correct copy of the entirety of such proceeding as so adopted by said Board.
5. That all members of the Board of the Issuer had due notice of said meeting.
6. That said meeting was open to the general public in accordance with Section 103 of the Public Officers Law, commonly referred to as the "Open Meetings Law".
7. That notice of said meeting (*the meeting at which the proceeding was adopted*) was caused to be given **PRIOR THERETO** in the following manner:

**PUBLICATION** (here insert newspaper(s) and date(s) of publication - should be a date or dates falling prior to the date set forth above in item 1)

**POSTING** (here insert place(s) and date(s) of posting- should be a date or dates falling prior to the date set forth above in item 1)

IN WITNESS WHEREOF, I have hereunto set my hand and affixed the seal of the Issuer this \_\_\_ day of \_\_\_\_\_, 2019.

\_\_\_\_\_  
Town Clerk

(CORPORATE SEAL)

At a special meeting of the Town Board of the Town of Newburgh, held at the Town Hall, 1496 Route 300, in the Town of Newburgh, Orange County, New York on the \_\_\_th day of October, 2019 at 10:00 o'clock a.m.

PRESENT:

Gilbert J. Piaquadio, Supervisor

Elizabeth J. Greene, Councilwoman

Paul I. Ruggiero, Councilman

James E. Presutti, Councilman

Scott M. Manley, Councilman

RESOLUTION OF TOWN BOARD  
APPROVING AND AUTHORIZING  
SUPERVISOR TO EXECUTE  
INTER-GOVERNMENTAL AGREEMENT  
BY AND BETWEEN  
THE TOWN OF NEWBURGH AND  
THE CITY OF NEW YORK FOR THE  
CONSTRUCTION OF CERTAIN IMPROVE-  
MENTS TO CHADWICK LAKE RESERVOIR  
AND WATER TREATMENT FILTRATION  
PLANT

Councilman/woman \_\_\_\_\_ presented the following resolution which was seconded by  
Councilman/woman \_\_\_\_\_.

**WHEREAS**, the Town of Newburgh (hereinafter the "Town") and the City of New York (hereinafter the "City") (hereinafter the Town and the City together referred to as the "Parties") are both municipal corporations of the State of New York; and

**WHEREAS**, the City acting by and through the New York City Department of Environmental Protection ("DEP"), operates and maintains the New York City water supply system and is responsible for providing drinking water to more than eight million residents in the City, as well as approximately one million upstate residents, including users who rely on a water supply from connections to the City's Delaware Aqueduct, including the Town; and

**WHEREAS**, DEP has identified leaks in sections of the Delaware Aqueduct and has committed capital funds to address such leaks to ensure the long-term sustainability of its ability to supply water through the Delaware Aqueduct, as part of a project known as "Water for the Future" ("WFF"); and

**WHEREAS**, in connection with WFF, DEP is constructing a new tunnel segment to bypass a leaking section of the existing Delaware Aqueduct tunnel, which will require DEP shutting down the Delaware Aqueduct for extended periods of time; and

**WHEREAS**, each of the communities that take water from the New York City water supply are required to maintain a back-up water supply system and enter into a water supply agreement with the New York City Water Board; and

**WHEREAS**, the Town, for and on behalf of its Consolidated, Colden Park, Fleetwood-Holiday Park and ANG Water Districts ("Consolidated Water District"), duly formed and extended pursuant to the provisions of Articles 12 and/or 12A of the Town Law of the State of New York, is the owner and operator of a water supply and distribution system which delivers potable water, including water taken from the New York City water supply and treated by the Town, to properties in the Town and to the Town of Marlborough; and



**WHEREAS**, the Town has commissioned the preparation of an engineering study by Henningson, Durham, and Richardson Architecture and Engineering, P.C., "Engineering Evaluation of Long-Term Use & Economic Viability of the Chadwick Lake Reservoir and Filter Plant," dated November 2017 (the "Engineering Study") for the purpose of evaluating the reliability of the Chadwick Lake Water Treatment Filtration Plant ("WTFP") to meet the Town's back-up water supply needs for this purpose; and

**WHEREAS**, the Engineering Study sets forth certain recommendations for improvements to the Chadwick Lake WTFP to allow the Town to meet its water demand during the WFF shut-downs; and

**WHEREAS**, in order to assist the Town, which relies on the New York City water system as its primary source of water supply, in ensuring its ability to sustain an extended shutdown of the Delaware Aqueduct for DEP's operational needs, DEP has agreed to provide up to \$1,823,900 in funding to be used towards the construction of certain short-term improvements to the Chadwick Lake WTFP in accordance with an inter-governmental Agreement between the Parties for the Construction of Certain Improvements to Chadwick Lake Reservoir and Water Treatment Filtration Plant (the "Agreement"); and

**WHEREAS**, the Town has agreed to fund the design of the Chadwick Lack WTFP improvements, manage the design and construction of the Chadwick Lake Water Treatment Filtration Plant improvements, and administer the DEP funding in accordance with the terms and conditions of the Agreement.

**WHEREAS**, the Town Board of the Town of Newburgh has reviewed the terms and conditions of the Agreement and finds the Agreement acceptable and in the best interests of the Town of Newburgh and the Town of Newburgh's water districts; and

**WHEREAS**, the Town Board desires to authorize the execution of the Agreement

**NOW, THEREFORE BE IT RESOLVED**, that the Town Board of the Town of Newburgh approves the Agreement by and between the Town of Newburgh and the City of New York as to its form and manner of execution and hereby authorizes the Supervisor to execute and deliver the Agreement.

The question of the adoption of the foregoing resolution was duly put to a vote on roll call which resulted as follows:

<u>Elizabeth J. Greene, Councilwoman</u>	voting _____
<u>Paul I. Ruggiero, Councilman</u>	voting _____
<u>James E. Presutti, Councilman</u>	voting _____
<u>Scott M. Manley, Councilman</u>	voting _____
<u>Gilbert J. Piaquadio, Supervisor</u>	voting _____

The resolution was thereupon declared duly adopted.

STATE OF NEW YORK )  
COUNTY OF ORANGE ) SS:  
TOWN OF NEWBURGH )

I, Joseph P. Pedi, Town Clerk of the Town of Newburgh, DO HEREBY CERTIFY that I have compared the foregoing resolution, duly adopted by the Town Board of the Town of Newburgh on the \_\_\_th day of October, 2019, and entered in the minutes of the proceedings of said Board, and that the foregoing is a true and correct copy of said resolution and the whole thereof.

IN WITNESS WHEREOF, I have hereunto set my name and the seal of said Town on this \_\_\_\_\_ day of October, 2019.

---

Joseph P. Pedi, Town Clerk

**AGREEMENT BETWEEN  
THE CITY OF NEW YORK AND THE  
TOWN OF NEWBURGH FOR THE CONSTRUCTION OF  
CERTAIN IMPROVEMENTS TO CHADWICK LAKE  
RESERVOIR AND WATER TREATMENT FILTRATION PLANT**

**THIS AGREEMENT** (“Agreement”) is made and entered into as of the \_\_\_\_ day of \_\_\_\_\_, 2018, by and between the **CITY OF NEW YORK** (the “City”), a municipal corporation of the State of New York, acting by and through the **NEW YORK CITY DEPARTMENT OF ENVIRONMENTAL PROTECTION** (“DEP”), having its principal office at 59-17 Junction Boulevard, Flushing, New York 11373, and the **TOWN OF NEWBURGH**, New York (the “Town”), a municipal corporation of the State of New York having its principal office at 1496 Route 300, Newburgh, New York 12550 (each, a “Party” and collectively, the “Parties”).

**WHEREAS**, DEP operates and maintains the New York City water supply system and is responsible for providing drinking water to more than eight million residents in the City, as well as approximately one million upstate residents, including users who rely on a water supply from connections to the City’s Delaware Aqueduct , including the Town; and

**WHEREAS**, DEP has identified leaks in sections of the Delaware Aqueduct and has committed capital funds to address such leaks to ensure the long-term sustainability of its ability to supply water through the Delaware Aqueduct, as part of a project known as “Water for the Future” (“WFF”); and

**WHEREAS**, in connection with WFF, DEP plans to construct a new tunnel segment to bypass a leaking section of the existing Delaware Aqueduct tunnel, which will require DEP shutting down the Delaware Aqueduct for extended periods of time; and

**WHEREAS**, each of the communities that take water from the New York City water supply are required to maintain a back-up water supply system and enter into a water supply agreement with the New York City Water Board; and

**WHEREAS**, the Town, for and on behalf of its Consolidated, Colden Park, Fleetwood-Holiday Park and ANG Water Districts (“Consolidated Water District”), duly formed and extended pursuant to the provisions of Articles 12 and/or 12A of the Town Law of the State of New York, is the owner and operator of a water supply and distribution system which delivers potable water, including water taken from the New York City water supply and treated by the Town, to properties in the Town and to the Town of Marlborough; and

**WHEREAS**, the Town has commissioned the preparation of an engineering study by Henningson, Durham, and Richardson Architecture and Engineering, P.C., “Engineering Evaluation of Long-Term Use & Economic Viability of the Chadwick Lake Reservoir and Filter Plant,” dated November 2017 (the “Engineering Study”) for the purpose of evaluating the reliability of the Chadwick Lake Water Treatment Filtration Plant (“WTFP”) to meet the Town’s back-up water supply needs for this purpose; and

**WHEREAS**, the Engineering Study sets forth certain recommendations for improvements to the Chadwick Lake WTFP to allow the Town to meet its water demand during the WFF shut-downs; and

**WHEREAS**, in order to assist the Town, which relies on the New York City water system as its primary source of water supply, in ensuring its ability to sustain an extended shutdown of the Delaware Aqueduct for DEP’s operational needs, DEP has agreed to provide up to \$1,823,900 in funding to be used towards the construction of certain short-term improvements to the Chadwick Lake WTFP; and

**WHEREAS**, the Town has agreed to fund the design of the Chadwick Lack WTFP improvements, manage the design and construction of the Chadwick Lake WTFP improvements, and administer the DEP funding in accordance with the terms of this Agreement;

**NOW, THEREFORE**, in consideration of the respective representations and agreements contained below, the Parties agree as follows:

**1. Registration Required**

This Agreement shall not take effect until it is registered pursuant to Section 328 of the New York City Charter. The date of registration shall be referred to as the “Effective Date” of this Agreement.

2. **Expiration, Termination and Extension of Agreement**

Unless otherwise extended in writing signed by both Parties, with the approval of the DEP Agency Chief Contracting Officer (the "ACCO"), and except for the provisions herein which expressly survive this Agreement, this Agreement shall expire on the fourth anniversary of the Effective Date, unless terminated sooner pursuant to the terms of this Agreement.

3. **Chadwick Lake Reservoir WTFP Improvement Project**

a) The services to be completed by the Town pursuant to this Agreement shall consist of the construction of the short-term improvements to the WTFP as described below (the "Project"), to ensure operation that will yield a minimum of 2.0 million gallons per day ("GPD") of potable water during the Delaware Aqueduct shutdowns:

- (i) Installation of water quality monitoring equipment in Chadwick Lake Reservoir;
- (ii) Installation of a powder activated carbon ("PAC") feed system for total organic carbon ("TOC") removal, along with necessary bench tests;
- (iii) Installation of a temporary trailer-mounted membrane filtration unit;
- (iv) Construction of a third solids handling tank; and
- (v) Installation of a floating decanter in each of two existing and one new solids handling tanks.

b) The Project shall be constructed pursuant to a design completed by the Town at its own expense, through its own professional staff or through consultants who, if necessary, are licensed to practice engineering in the State. The design shall implement the conceptual plan that is described in Section 4.1 of Attachment 4 of the Engineering Study, a copy of which is annexed hereto as Exhibit A, and shall include the preparation of plans and specifications that comply with all applicable standards set by the New York State Department of Health ("NYSDOH") and New York State Department of Environmental Conservation and with all applicable federal, New York State ("State") and local laws (the "Plans and Specifications").

c) In accordance with the milestones on Exhibit B, the Town shall submit the Plans and Specifications to DEP for review when they are ninety (90%) percent complete, together with the bid documents for the proposed Project construction contract(s) ("Construction Contract(s)"). DEP shall review and comment upon the Plans and Specifications within two weeks. To the maximum extent possible, the Town shall incorporate any revisions necessitated by DEP's comments in its final plans and specifications. A copy of the final bid solicitation package shall be provided by the Town to DEP on its release date.

d) The Project shall be managed by the Town. The Town shall be responsible for ensuring that all necessary permits, consents and approvals are obtained, for and making of any and all notifications necessary to carry out the Project, and for making all necessary modifications to its existing permits that may be affected by the Project, in a timely manner to ensure that the milestones on Exhibit B are met. Upon request, the Town shall provide DEP with a copy of any permit application. In the event that the Town learns that it may not obtain a necessary approval, consent or permit prior to the date upon which such work must be undertaken to meet the milestone dates set forth on Exhibit B, it shall notify DEP immediately, in writing, in accordance with the provisions of Section 14, below.

The Town will be responsible for completing the Project in accordance with the milestones on Exhibit B hereto. Failure to do so will give DEP the option to declare an event of default under this Agreement.

4. **Public Letting of Construction Contract(s)**

a) Following determination by the Town Board after public hearing that the acquisition or construction, as the case may be, of the Project improvements is in the public interest, the Town shall take all steps necessary under applicable law, including, without limitation, the Wicks Law, to advertise and bid out and award the Construction Contract(s).

b) Promptly after the opening of the sealed bids, the Town shall provide DEP with a list of the bidders' names and the bid amounts.

c) Within three business days of the Town providing such notice of bidders, DEP shall have the opportunity to provide notice to the Town that, in DEP's opinion, the lowest bidder does not have a satisfactory record of business integrity, would otherwise be found to be a non-responsible bidder by DEP or that DEP has reason to believe such bidder will be unable to complete the relevant Construction Contract according to the applicable Plans and Specifications. If DEP does not provide notice of an objection to the Town within three business days, DEP shall waive its opportunity to object to award of a Construction Contract to the lowest responsive bidder.

d) The Town shall award one or more Construction Contract(s) (which may allow for subcontracting) for the construction work, in compliance with the Wicks Law, if applicable. The Town shall immediately notify DEP, in writing, of any Construction Contract award.

5. **Construction Work**

a) The commencement of construction work pursuant to the Plans and Specifications (the "Construction Work") shall not occur prior to:

i) the Town's completion of all actions necessary to conduct a review as the lead agency in compliance with the requirements set forth under the State Environmental Quality Review Act ("SEQRA") for the Project;

ii) the Town's receipt of all approvals and permits and provision of all notices that are necessary under law or contract prior to commencing the Construction Work;

iii) the Town's having secured the necessary bonds and proof of insurance pursuant to Section 11, below;

iv) the Town's having provided to DEP a complete original set of the Plans and Specifications included in the bidding documents for the Construction Contract(s); and

(v) procurement by Town of design services during construction and construction management services to ensure the Project is built in accordance with the Plans and Specifications.

b) The Town shall ensure that the Construction Work is prosecuted diligently and performed in an orderly, expeditious and workmanlike manner and in substantial conformance with the Plans and Specifications and with the milestones set forth on Exhibit B. The Town's design engineer shall be required to certify that the work was completed in accordance with the approved Plans and Specifications.

c) DEP shall have the right (and the Town shall ensure that DEP shall have access to the work site as needed) to inspect the Construction Work from time to time to determine whether the Construction Work is being prosecuted in accordance with Section 5(b), above.

d) The Town must provide DEP with written notice of any and all change orders under the Construction Contract(s) prior to the approval thereof, unless necessitated by an emergency condition.

6. **Progress Reports**

The Town shall submit written monthly progress reports to DEP by email on the first day of each month after the Effective Date, which shall include, at a minimum, a written report on all work completed in the past month; work planned for completion in the upcoming month; and a description of any aspect of the Project that the Town anticipates may be delayed or not completed in accordance with the milestones established in Exhibit B, for any reason, and a description of any Construction Work that may not or will not be completed in accordance with the Plans and Specifications.

7. **Costs**

a) **Eligible Costs.** Subject to the restrictions set forth in this Section 7, DEP agrees to pay for the reasonable and necessary costs associated with the construction of the Project in accordance with the terms and conditions in this Agreement, but not including any costs for time spent of the Project by employees of the Town ("Eligible Costs"). The Eligible Costs shall be limited to the actual cost of the Construction Work performed in accordance with Construction Contract(s) that have been competitively bid and awarded pursuant to General Municipal Law §103, which may include the cost of Project-specific commercial general liability insurance of both the Town and its contractor(s) and/or performance and payment



bonds required by this Agreement, and other costs directly related to the Construction Work on the Project that may be approved by DEP in writing in advance of the Town expending such amounts. In no event shall any costs associated with the design work performed prior to or during construction, construction management, Town overhead, or operation or maintenance of the Project or WTPF constitute Eligible Costs.

b) Total Eligible Costs. Notwithstanding anything to the contrary herein, the aggregate total of all Eligible Costs payable by DEP hereunder shall not exceed one million eight hundred twenty-three thousand nine hundred and 00/100 dollars (\$1,823,900.00) (“Total Eligible Costs”). The Town shall be responsible for any and all Project costs above the Total Eligible Costs, and for any costs or expenses that are determined by DEP to not qualify as an Eligible Cost.

c) Administration of Funds by the Town. The Town shall manage, coordinate and administer the costs and payments required in connection with the Construction Work in accordance with the terms hereof, including compliance with the milestones set forth in Exhibit B. The Town shall deposit all funds received pursuant to this Agreement in an account not to be co-mingled with funds from other sources and shall use such funds solely to fulfill its obligations hereunder. In no event shall any funds distributed by DEP to the Town under this Agreement be used for any expense other than Eligible Costs.

8. **Payment**

The City shall pay the Town for Eligible Costs for Construction Work actually performed as set forth below:

a) After the Effective Date, the Town shall submit to DEP itemized vouchers specifying the work performed, and the amount of compensation requested, and including appropriate documentation including, but not limited to, invoices from all contractors and subcontractors, and a cover letter from the Town verifying that all costs are reasonable and fair and were authorized in good faith and in accordance with all applicable laws. DEP shall release funds on a reimbursement basis after it confirms that all of the Town's obligations under this Agreement have been complied with, but not more frequently than once a month.

b) Payments by the Town. The Town must require that all requests for payments from the Town by its contractors for Eligible Costs be made by itemized voucher. Such vouchers shall include documentation demonstrating that the services for which payment is sought have actually been performed, and that the vouchers cover an Eligible Cost as defined in this Agreement. Where appropriate, the documentation supporting the voucher may include items such as purchase orders, canceled checks, certified payroll records and machinery use records. The Town shall ensure that all funds advanced or released to it shall be used exclusively for Eligible Costs incurred in connection with Project construction activities as set forth herein.

c) Right to Examine Books. All receipts and disbursements of funds pursuant to this Agreement are subject to audit by the City or the State and the Town agrees to cooperate with any such audit of this Agreement.

d) Delays or Incomplete Work. If the Town is in material breach of the terms of this Agreement, including the milestone schedule set forth on Exhibit B, and such breach is not cured in accordance with Section 29, below, in addition to any other rights or remedies available to it at law or in equity, the City shall be entitled to withhold payment otherwise due to the Town in an amount that represents the cost to cure the breach and covers any reasonable damages resulting directly from such breach until such breach is cured.

e) Payment Disputes. In the event of a dispute between the Town and DEP as to the Town's documentation or expenditures, it is understood and agreed that such dispute shall be brought to the Commissioner of DEP (the "Commissioner") for a determination. The Commissioner shall examine the material submitted by each Party and may, in his or her discretion, convene an informal conference with the Parties and any other designee of the Commissioner to resolve the issue by mutual consent prior to reaching a determination. The Commissioner may seek such technical or other expertise as he or she shall deem appropriate, including the use of neutral mediators, and require any such additional material from either Party or both Parties as he or she deems fit.

f) Survival of Expiration or Termination. The City's payment obligations hereunder for work performed prior to the expiration or earlier termination of this Agreement, shall survive such expiration or termination.

9. **Maintenance of the Project Improvements**

The improvement to the Chadwick Lake WTFP shall be owned and maintained by the Town for and on behalf of its Consolidated Water District. The City shall not take title to and shall not be responsible for the repair or maintenance of such improvements constructed and installed pursuant to this Agreement. The provisions of this Section shall survive the expiration or termination of this Agreement.

10. **Independent Contractors**

a) The Town and the City agree that the Town is an independent contractor and not an employee, subsidiary, affiliate, division, department, agency, office, or unit of the City. Accordingly, the Town and its employees, officials, officers, and agents shall not, by reason of this Agreement or any performance pursuant to or in connection with this Agreement, assert the existence of any relationship or status on the part of the Town, with respect to the City, that differs from or is inconsistent with that of independent contractor.

b) All persons who are employed by the Town and all the Town's contractors (including without limitation, consultants and independent contractors) that are retained to perform

services under or in connection with this Agreement are neither employees of the City nor under contract with the City. The Town, and not the City, is responsible for their work, direction, compensation, and personal conduct while the Town is engaged under this Agreement. Nothing in this Agreement, and no entity or person's performance pursuant to or in connection with this Agreement, shall create any relationship between the City and the Town's employees, agents, contractors, or contractor's employees or agents (including without limitation, a contractual relationship, employer-employee relationship, or quasi-employer/quasi-employee relationship) or impose any liability or duty on the City (i) for or on account of the acts, omissions, liabilities, rights or obligations of the Town, its employees or agents, its contractors, or its contractor's employees or agents (including without limitation, obligations set forth in any collective bargaining agreement); or (ii) for taxes of any nature; or (iii) for any right or benefit applicable to an official or employee of the City or to any officer, official, agent, or employee of the Town or any other entity (including without limitation, Workers' Compensation coverage, Employers' Liability coverage, Disability Benefits coverage, Unemployment Insurance benefits, Social Security coverage, employee health and welfare benefits or employee retirement benefits, membership or credit). The Town and its employees, officers, and agents shall not, by reason of this Agreement or any performance pursuant to or in connection with this Agreement, (i) hold themselves out as, or claim to be, officials or employees of the City, including any department, agency, office, or unit of the City, or (ii) make or support in any way on behalf of or for the benefit of the Town, its employees, officers, or agents any demand, application, or claim upon or against the City for any right or benefit applicable to an official or employee of the City or to any officer, official, agent, or employee of the Town or any other entity. Except as specifically stated in this Agreement, nothing in the Agreement and no performance pursuant to or in connection with the Agreement shall impose any liability or duty on the City to any person or entity whatsoever.

11. **Insurance**

a) Prior to the Effective Date of this Agreement, the Town must provide evidence that it has procured, and must maintain throughout the term of this Agreement, the insurance set forth in Part I of Exhibit C hereto. The City, together with its officials and employees, shall be

named as an additional insured on the required commercial general liability insurance policies as set forth in Exhibit C.

b) Before they commence any Construction Work on the Project, the Town shall require its contractors and subcontractors to procure and provide evidence of insurance in the types and amounts set forth in Part II of Exhibit C hereto, and require that such insurance be maintained during the entire period of their respective contracts to provide such work. The City, together with its officials and employees, shall be named as an additional insureds (without a requirement of privity of contract) on the required commercial general liability insurance as set forth in Exhibit C. Proof of insurance for each and every policy required hereunder, as required in Exhibit C, shall be furnished to DEP for review and approval before the relevant work is commenced.

c) In addition to other bonds required by law, if any, for the performance and completion of the Construction Work, the Town shall require its construction contractor(s) to provide a performance bond or other security acceptable to the City, in a form acceptable to the City. The performance bond or other security shall name the City and the Town as obligees in the full amount of the cost of the work to be performed by the contractor, shall be issued by a surety company qualified to do business in the State, and shall secure the faithful performance and completion of all work required of the contractor. In addition, the Town shall require the contractor(s) to provide a payment bond or other security acceptable to the City in the full amount of the work to be performed by the contractor guaranteeing prompt payment of monies due to all persons furnishing labor or materials in the prosecution of the Construction Work, as required by State Finance Law Section 137.

12. **Indemnification**

a) To the fullest extent permitted by law, the Town shall indemnify, defend and hold the City and its officials and employees (the "Indemnitees") harmless against any and all claims (including, but not limited to, claims asserted by any employee of the Town or any of its consultants and/or contractors) and costs and expenses of whatever kind (including, but not limited to, payment or reimbursement of reasonable attorneys' fees and disbursements)

allegedly arising out of or in any way related to the operations of the Town and its consultants, subconsultants, contractors and/or subcontractors in the performance of this Agreement or the Town's and/or its consultants', subconsultants, contractors, and/or subcontractors' failure to comply with any of the provisions of this Agreement or of the law. Such costs and expenses shall include all those incurred in defending the underlying claim and those incurred in connection with the enforcement of this Section 12 by way of cross-claim, third-party claim, declaratory judgment action or otherwise. The Parties expressly agree that the indemnification obligation hereunder contemplates (i) full indemnity in the event of liability imposed against the Indemnitees without negligence and solely by reason of statute, operation of law or otherwise; and (ii) partial indemnity in the event of any actual negligence on the part of the Indemnitees either causing or contributing to the underlying claim (in which case, indemnification will be limited to any liability imposed over and above that percentage attributable to actual fault whether by statute, by operation of law, or otherwise). Where partial indemnity is provided hereunder, all costs and expenses shall be indemnified on a *pro rata* basis.

b) The Town shall include a provision in all of its contracts for the Construction Work covered by this Agreement requiring that its contractors shall indemnify, defend and hold the Indemnitees harmless to the same extent set forth in paragraph (a), immediately above, provided that such indemnification, defense and hold-harmless provisions may be restricted to operations and failures to comply by the respective contractor, and need not include operations and failures to comply by the Town unrelated to the contractor and by unrelated contractors.

c) Indemnification under this Section or any other provision of this Agreement shall operate whether or not the Town and its contractors and/or subcontractors have placed and maintained the insurance required under Section 11.

d) The Town waives all rights against the City, including its officials and employees, for any damages or losses for which either is covered under any insurance required under this Agreement (whether or not such insurance is actually procured) or any other insurance applicable to the operations of a consultant or contractor of the Town.

e) The provisions of this Section shall not be deemed to create any new right of action in favor of any third parties against the City.

13. **Acceptance of Final Payment**

The acceptance by the Town, or by anyone claiming by or through it, of final payment under this Agreement, whether such payment be made pursuant to any judgment of any court or otherwise, shall constitute and operate as a release of the City from any and all claims of and liability to the Town for anything heretofore done or furnished by the Town relating to or arising out any work done pursuant to the terms of this Agreement, and for any prior act, neglect or default on the part of the City or any of its officers, agents or employees, excepting only a claim against the City for the amounts deducted or retained in accordance with the terms and provisions of this Agreement or law.

14. **Notices**

All notices required or permitted hereunder shall, unless otherwise specified, be in writing and be delivered by hand, or by overnight mail or by certified mail, return receipt requested, to the Parties at the following respective addresses:

To DEP :

New York City Department of Environmental Protection  
71 Smith Avenue  
Kingston, New York 12401  
Attn: Dan Michaud, Project Manager

With a copy to:

New York City Department of Environmental Protection  
Bureau of Legal Affairs  
59-17 Junction Boulevard, 19th Floor  
Flushing, New York 11373  
Attn: General Counsel

To the Town:

Town Supervisor  
1496 Route 300  
Newburgh, New York 12550

With copies to:

Town Engineer  
1496 Route 300  
Newburgh, New York 12550

and

Town Attorney  
1496 Route 300  
Newburgh, New York 12550

Either Party may, from time to time, change its address(es) for notices by giving notice of such change to the other Party in the manner specified in this Section.

15. **Compliance with Public Procurement Requirements**

The contemplated Construction Contract(s) for the Construction Work will be contract(s) for "public work" as such term is defined in Article 5-A of the General Municipal Law of the State. The Town shall, in soliciting or procuring contracts for any of the Project work, comply with all public procurement requirements that are applicable to the Town under State or local law, or that would be applicable to the Town under State or local law or any regulations thereunder if it were funding such work itself. The Construction Contract(s) may permit subcontracting of the work under said contract(s) provided that all subcontracts comply with applicable law and regulations for public works contracts including, without limitation, the Wicks Law.

16. **Administration of Contracts**

The Town shall be responsible for administering all contracts necessary to complete the Project work in such a manner as to ensure compliance with all applicable laws and regulations. Upon request, the Town shall provide DEP with a copy of any contract entered



into by it with respect to any aspect of the Project and of any subcontract entered into by its contractor(s).

17. **Construction Contract(s)**

a) Any contract between the Town and any person, firm or other entity for the performance of the Construction Work, and any subcontract thereunder, shall contain the following:

(i) a requirement that the contractor or subcontractor, as applicable, perform such work in accordance with the terms hereof, and with all applicable federal, State and local laws and regulations;

(ii) a provision requiring the contractor or subcontractor, as applicable, to indemnify the Indemnitees to the same extent and on the same conditions set forth in Section 12 of this Agreement;

(iii) a provision stating that nothing in such contract or subcontract shall be deemed to create any contractual relationship between the contractor or subcontractor and the City;

(iv) a provision stating that nothing contained in such contract or subcontract shall impair the rights of the City under this Agreement;

(v) a requirement that the contractor or subcontractor, as applicable, obtain insurance upon the terms and conditions and in the amounts set forth in Section 11 and Exhibit C;

(vi) a statement that the contractor or subcontractor, as applicable, has not engaged and will not engage in any unlawful discrimination based upon actual or perceived race, color, creed, religion, religious practice, political beliefs or affiliations, ancestry, national origin, sex, sexual orientation, gender, disability or other handicap, predisposing genetic characteristics, pregnancy, age, veteran or military status, marital/familial status, partnership status, arrest or conviction record, status as a victim of domestic violence, stalking or sex offenses, unemployment status, or status with regard to public assistance or any

other class protected by federal, state or local law with respect to all employment decisions, including but not limited to, recruitment, hiring, upgrading, demotion, downgrading, transfer, training, rates of pay or other forms of compensation, layoffs, termination, and all other terms and conditions of employment;

(vii) a provision requiring that the contractor or subcontractor, as applicable, fully comply with all applicable prevailing wage requirements and all other applicable requirements of Section 220 of the State Labor Law; and

(viii) a provision making any subcontracting or sub-subcontracting by the contractor or subcontractor, as applicable, subject to approval by the Town.

b) Except for any contract between the Town and its employees, the Town agrees not to enter into any subcontracts for, or assignment of, the performance of its obligations under this Agreement, in whole or in part, without the prior written approval of DEP.

c) The Town agrees that it is fully responsible to DEP for the acts and omissions of its contractors and subcontractors and of persons either directly or indirectly employed by such contractors and subcontractors as it is for the acts and omissions of any person directly employed by it.

d) The Town shall not in any way be relieved of any of its responsibilities, duties and liabilities under this Agreement by virtue of entering into any contract or subcontract for the performance of any portion of the Project work.

18. **The Town's Representations and Warranties**

a) The Town represents and warrants that:

(i) it has all requisite power and authority to execute, deliver and perform this Agreement;

(ii) this Agreement has been duly authorized by all necessary action on its part, has been duly executed and delivered by the Town and, assuming due execution and delivery by the City and registration under Section 328 of the City Charter, constitutes the legal, valid and binding agreement of the Town, enforceable in accordance with its terms; and

(iii) the execution and delivery of this Agreement, and compliance with the provisions hereof, do not and will not conflict with or constitute a violation or default under any provision of applicable law, charter, ordinance or regulation or to the extent of its knowledge, of any material agreement, judgment, injunction order, decree or other instrument binding upon it.

b) Acceptance by the Town of funds from DEP hereunder shall be deemed at such time to be a reaffirmation of the foregoing representations and warranties.

19. **No Discrimination**

The Town agrees that it has not and will not, in connection with the performance of this Agreement, engage in any unlawful discrimination based upon actual or perceived race, color, creed, religion, religious practice, political beliefs or affiliations, ancestry, national origin, sex, sexual orientation, gender, disability or other handicap, predisposing genetic characteristics, pregnancy, age, veteran or military status, marital/familial status, partnership status, arrest or conviction record, status as a victim of domestic violence, stalking or sex offenses, unemployment status, or status with regard to public assistance or any other class protected by federal, state or local law with respect to all employment decisions including, but not limited to, recruitment, hiring, upgrading, demotion, downgrading, transfer, training, rates of pay or other forms of compensation, layoffs, termination, and all other terms and conditions of employment.

20. **Compliance with Law**

The Town agrees that it will comply with all federal, State and local laws, rules and regulations in performing its obligations hereunder and in prosecuting and ensuring the completion of the Project.

21. **Incorporation of Applicable Laws**

The Parties agree that each and every provision of federal, State or local law, rule, regulation or order applicable to this Agreement, that is required to be included in this Agreement, is incorporated herein by this reference. Furthermore, it is hereby stipulated that every such provision is to be deemed inserted herein, and if, through mistake or otherwise, any such provision is not inserted or is not inserted in correct form, then this Agreement shall forthwith, upon the application of either Party, be amended by any such insertion so as to comply strictly with such law, rules, regulation or order and without prejudice to the rights of either Party.

22. **Cooperation with Investigations**

The Parties agree to cooperate fully and faithfully with any investigation, audit or inquiry relating to the subject matter of this Agreement conducted by a State, City or other municipal governmental agency or authority that is empowered directly or by designation to compel the attendance of witnesses and to examine witnesses under oath, or conducted by the Inspector General of a governmental agency or entity that is a party in interest to the transaction, submitted bid, submitted proposal, contract, lease, permit or license that is the subject of the investigation, audit or inquiry. Any breach or violation of the foregoing may be deemed a breach or violation of a material provision of this Agreement.

23. **Copyrights and Access to Information**

The City shall have the right to use all written materials, documents, data and information that are gathered or prepared pursuant to the Agreement for any purpose deemed appropriate by the City. In furtherance thereof, the Town hereby grants to the City a royalty-free, worldwide, non-exclusive, perpetual, irrevocable license to use, execute, reproduce, make,

modify, adapt, display, perform and create derivative works of, all written material, documents, data and information that are gathered or prepared pursuant to this Agreement, including, but not limited to, all designs, plans, specifications and models created hereunder for which the Town has obtained ownership rights.

24. **Infringements**

The Town shall defend, indemnify and hold the City harmless from any and all claims (even if the allegations of the lawsuit are without merit) or judgments for any damages and from the costs and expense to which the City may be subject or which it may suffer or incur allegedly arising out of or in connection with any infringement by the Town, or any of its consultants, subconsultants, contractors, and/or subcontractors of any copyright, trademark, trade secrets or patent rights or any other property or personal right of any third party in the performance of this Agreement. Insofar as the facts or law relating to any claim would preclude the City from being completely indemnified by the Town, the City shall be partially indemnified by the Town to the fullest extent permitted by law.

25. **No Claim Against Officers, Agents or Employees**

No claim whatsoever shall be made by either Party against any individual officer, agent or employee of the other Party for, or on account of, anything done or omitted in connection with this Agreement.

26. **Waiver**

Neither Party shall be deemed to have waived the observance or performance of any term or provision of this Agreement, or any default hereunder, except pursuant to a written instrument of waiver signed by such Party. No waiver of the observance or performance of any term or provision of this Agreement, or of any default hereunder, shall be deemed to be a waiver of any subsequent failure to observe or perform this Agreement, or of any subsequent default hereunder.

27. **Retention of Records**

a) The Town agrees to retain all books, records and other documents relevant to this Agreement for six years after the final payment under, or termination of, this Agreement, whichever is later. City, State and federal auditors and any other persons duly authorized by DEP or the Town shall have full access to and the right to examine any of said materials during said period, including ensuring that any funds administered under this Agreement were applied in accordance with the terms and conditions herein. The Parties shall have the right, at any time during normal business hours, to inspect, examine and/or make copies of any such books, records or other documents. The same right shall be afforded to representatives of the State Comptroller or the City Comptroller, or any other person duly authorized by DEP or the Town.

b) All receipts, management and disbursements of funds provided by the City pursuant to this Agreement, and the records and accounts evidencing such receipts, management and disbursements, shall be subject to audit by the State Comptroller and by the City, including the City Comptroller, pursuant to the rights and powers of such officials as conferred upon them by State and City law. The Town agrees to cooperate with any such audits.

c) The Town shall prepare and maintain its records and accounts of receipts, management and disbursements of funds under this Agreement in accordance with generally accepted government accounting standards and shall provide a summary of such records and accounts to DEP as requested.

28. **Early Termination**

The City may terminate this Agreement in the event that:

a) any litigation has been filed and served upon the Town that would, in DEP's reasonable opinion, materially, adversely affect the Town's ability to fulfill the obligations herein and meet the milestones in Exhibit B, upon fifteen days written notice to the Town and failure by the Town to cure within such period, except in the event the DEP or City has commenced such litigation;

- b) the Town has failed to meet, or in DEP's reasonable opinion, the Town's progress reports indicate it is likely to fail to meet, one of the milestones in Exhibit B upon fifteen days written notice to the Town and failure by the Town to cure within such period, except in the event the DEP has caused such delay; or
- c) the City determines there has been a material default under any provision hereof and such breach has not been cured by the Town in accordance with Section 29.

29. **Default**

- a) If either Party defaults in the observance or performance of any material term of this Agreement, and such default continues for more than fifteen calendar days after written notice of such default is received by the defaulting Party from the non-defaulting Party, the non-defaulting Party may, in addition to any other rights or remedies available at law or in equity, suspend its performance or terminate this Agreement by written notice of suspension or termination to the defaulting Party, specifying a date of suspension or termination which shall not be less than five business days from the date such notice is sent. However, if such default cannot reasonably be cured within fifteen calendar days, the Agreement may not be terminated if: (i) the defaulting Party commences appropriate actions to cure the default prior to the end of the fifteen day period, (ii) such actions have been approved in writing by the non-defaulting Party, and (iii) the defaulting Party thereafter diligently prosecutes the actions necessary to cure the default to the complete satisfaction of the non-defaulting Party.
- b) In addition to any other right or remedy available to DEP at law or in equity, if the Town defaults in the observance or performance of any material term of this Agreement, including compliance with the milestones set forth on Exhibit B hereto (which shall be deemed a default of a material term of this Agreement), and such default continues for more than fifteen calendar days after written notice of such default is received by the Town from DEP, DEP may withhold future payments to the Town. However, if such default cannot reasonably be cured within fifteen calendar days, the Agreement may not be terminated if: (i) the Town commences appropriate actions to cure the default prior to the end of the fifteen day period, (ii) such actions have been approved in writing by DEP, such approval not to be delayed, and

(iii) the Town thereafter diligently prosecutes the actions necessary to cure the default to the complete satisfaction of DEP.

30. **Force Majeure**

The period of time during which either Party is prevented or delayed in any performance or fulfilling of any obligation under this Agreement, other than the payment of money, due to unavoidable delays caused by fire, catastrophe, strikes or labor trouble, civil commotion, Acts of God, prohibition by a governmental agency of proper jurisdiction enacted or issued after the date of execution of this Agreement (not including a failure to obtain a necessary approval), acts of the public enemy or acts of terrorism, shall not be considered a basis for default under this Agreement. Notwithstanding the occurrence of such a *force majeure* event, in the event that DEP determines that the Town will not be able to meet the milestones in Exhibit B hereto, or in the event of a prohibition by a governmental agency, DEP may terminate this Agreement in accordance with the terms herein. As a condition to the Town's right to avail itself of a *force majeure* defense, it must give DEP written notice of such claimed force majeure event not later than three business days following the occurrence of such *force majeure* event.

31. **Amendments**

This Agreement may not be modified or amended except by an instrument in writing signed by both of the Parties and the Office of the City's Corporation Counsel. This Agreement can be terminated by mutual agreement with the written consent of both Parties.

32. **No Third-Party Beneficiaries**

This Agreement does not, and is not intended to, confer any rights or remedies upon any person or entity other than the Parties.

33. **Assignment**

This Agreement may not be assigned, in whole or in part, except pursuant to a written instrument signed by both of the Parties.



34. **Cooperation; Obligation to Provide Documents**

Both Parties acknowledge and agree that during the term of this Agreement each shall cooperate with the other and provide each other promptly with all documentation, reports, and information that may be necessary to carry out their respective obligations under this Agreement.

35. **Choice of Law; Specific Performance**

a) This Agreement shall be governed by and construed in accordance with the laws of the State. To the fullest extent permitted by law, the Parties consent to the jurisdiction of the Supreme Court of the State of New York in connection with any action by either Party against the other pursuant to this Agreement.

b) The Parties each hereby agree that irreparable damage would occur in the event that any provision of this Agreement were not performed in accordance with its specific terms or were otherwise breached, and that money damages or other legal remedies would not be an adequate remedy for any such damages. Accordingly, the Parties acknowledge and hereby agree that, unless this Agreement has been terminated in accordance with the terms set forth herein, in the event of any breach or threatened breach by the Town or DEP of any of their respective covenants or obligations set forth in this Agreement, the non-breaching Party shall be entitled to an injunction or injunctions to prevent or restrain breaches or threatened breaches of this Agreement, and to specifically enforce the terms and provisions of this Agreement to prevent breaches or threatened breaches of, or to enforce compliance with, the covenants and obligations of the other under this Agreement.

36. **Severability; Entire Agreement**

a) If any provision of this Agreement or its application is determined to be invalid, illegal or unenforceable in any respect, the validity, legality and enforceability of all other provisions and applications hereof shall not in any way be affected or impaired.

b) This Agreement constitutes the entire understanding between the Parties with respect to the subject matter hereof and supersedes all prior agreements with respect to such subject matter, whether written or oral.

37. Counterparts

This Agreement may be executed in counterparts, each of which shall be deemed an original, but all of which together shall constitute one and the same instrument.

**IN WITNESS WHEREOF**, the Commissioner of the New York City Department of Environmental Protection, or his or her designee, on behalf of the City and the Town Supervisor on behalf of the Town of Newburgh, have executed this Agreement, in quadruplicate, one part to be filed with the Comptroller of the City of New York, one part to be retained by the Department of Environmental Protection and two parts to be delivered to the Town of Newburgh.

THE CITY OF NEW YORK

TOWN OF NEWBURGH

BY: \_\_\_\_\_  
Name:  
Title:  
Department of Environmental Protection

BY: \_\_\_\_\_  
Name:  
Title: Town Supervisor

Dated: \_\_\_\_\_, 2018

Dated: \_\_\_\_\_, 2018

Approval as to Form and Certification as to Legal Authority

\_\_\_\_\_  
Acting Corporation Counsel of the City of New York  
Dated: \_\_\_\_\_

State of New York )

ss.:

County of )

On the \_\_\_\_ day of \_\_\_\_\_, in the year 2018, before me, the undersigned, personally appeared \_\_\_\_\_, personally known to me or proved to me on the basis of satisfactory evidence to be the individual(s) whose name(s) is(are) subscribed to the within instrument and acknowledged to me that he/she/they executed the same in his/her/their capacity(ies), and that by his/her/their signature(s) on the instrument, the individual(s) or person upon behalf of which the individual(s) acted, executed the instrument.

\_\_\_\_\_  
Notary Public

State of New York )

ss.:

County of )

On the \_\_\_\_ day of \_\_\_\_\_, in the year 2018 before me, the undersigned, personally appeared \_\_\_\_\_, personally known to me or proved to me on the basis of satisfactory evidence to be the individual(s) whose name(s) is(are) subscribed to the within instrument and acknowledged to me that he/she/they executed the same in his/her/their capacity(ies), and that by his/her/their signature(s) on the instrument, the individual(s) or person upon behalf of which the individual(s) acted, executed the instrument.

\_\_\_\_\_  
Notary Public



**Exhibit A**  
**Conceptual Plan**

**Exhibit B**  
**Milestones**

Complete preparation of 90% design Plans and Specifications	No later than 365 calendar days after Effective Date of the Agreement
Commence Construction Work	No later than 545 calendar days after Effective Date of the Agreement
Complete startup and testing and receive NYSDOH approval of completed Project	No later than August 30, 2022

**Exhibit C**  
**Insurance Requirements**

**Note:** All certificate(s) of insurance submitted pursuant to Section 8 of Part III of this Exhibit C must be accompanied by a Certification of Insurance Broker or Agent in the form at the end of this Exhibit C and include the following information:

- For each insurance policy, the name and NAIC number of issuing company, number of policy, and effective dates;
- Policy limits consistent with the requirements listed below;
- Additional insureds or loss payees consistent with the requirements listed below; and
- The name of this Agreement and the number assigned to it by the City (in the "Description of Operations" field).

All such certificate(s) of insurance (including Certification(s) of Insurance Broker or Agent, where required) must be sent to the New York City Department of Environmental Protection, as follows:

For insurance required from the Town, to:

NYCDEP  
Office of the ACCO  
59-17 Junction Blvd., 17<sup>th</sup> Floor  
Flushing, New York 11373

For insurance required from the Town's contractors, to:

NYCDEP  
Bureau of Water Supply  
ATTN: Project Manager (Dan Michaud)  
71 Smith Avenue  
Kingston, New York 12401

I. **Specific Types of Insurance Coverage Required to be Maintained by the Town of Newburgh (Agreement, Section 11):**

- Workers' Compensation                      Statutory per New York State Law without regard to jurisdiction (See Part III(1), below)
- Employers' Liability                              Statutory (See Part III(2), below)
- Disability Benefits Insurance                Statutory (See Part III(1), below)

- Commercial General Liability      \$2,000,000 per occurrence  
    \$1,000,000 personal and advertising injury  
    \$4,000,000 aggregate, per project  
    \$4,000,000 products/completed operations  
    Additional Insureds:  
    City of New York, including its officials and  
    employees, with coverage at least as broad as ISO  
    Forms CG 20 26 and CG 20 37  
    (See Part III(3), below, for additional requirements)
- Commercial Automobile Liability      \$1,000,000 per accident Combined Single Limit  
    (See Part III(4), below)

**II. Specific Types of Insurance Coverage Required to be Maintained by Contractors Retained by the Town of Newburgh (see Agreement, Section 11) (as per the provisions of this Exhibit C, including, without limitation, the below-listed section), with Minimum Limits and Special Conditions:**

- Workers' Compensation      Statutory per New York State Law  
    without regard to jurisdiction  
    (See Part III(1), below)
- Employers' Liability      Statutory (See Part III(2), below)
- Disability Benefits Insurance      Statutory (See Part III(1), below)
- Commercial General Liability      \$2,000,000 per occurrence  
    \$4,000,000 aggregate, per project  
    Additional Insureds:  
    City of New York, including its officials and  
    employees, with coverage at least as broad as  
    ISO Forms CG 20 26 and CG 20 37  
    (See Part III(3), below)
- Commercial Automobile Liability      \$1,000,000 per accident combined single limit  
    If vehicles are used for transporting hazardous  
    materials, the Contractor shall provide  
    pollution liability broadened coverage for  
    covered autos (endorsement CA 99 48) as  
    well as proof of MCS 90  
    (See Part III(4), below)



- Professional Liability Insurance (for all professional services contracts) \$1,000,000 per claim (See Part III(5), below)
- Builders' Risk (for construction contracts only; may be maintained by Town or its Contractor) 100% of the value of the Contract Work City should be named as "loss payee as its interests may appear" and additional insured (See Part III(6), below)

**III. General Provisions Applicable to Insurance Coverage:**

In each case below, the reference to "Contractor" shall mean the party required to maintain insurance coverage, and the reference to "Contract" shall mean the contract pursuant to which the or contractor is providing services to the Town pursuant to this Agreement, or, in the case of the Town's obligation to provide insurance, this Agreement itself.

**Section 1**      Worker's Compensation and Disability Benefits Insurance:

Before performing any work under the Contract, the Contractor shall procure Worker's Compensation and Disability Benefits Insurance in accord with the laws of the State of New York on behalf of all employees who are to provide labor or services under the Contract.

**Section 2**      Employer's Liability Insurance:

Before performing any work under the Contract, the Contractor shall procure Employer's Liability Insurance affording compensation due to bodily injury by accident or disease sustained by any employee arising out of and in the course of his or her employment under the Contract.

**Section 3**      Commercial General Liability:

The Contractor shall provide Commercial General Liability Insurance covering claims for property damage and/or bodily injury, including death, and personal and advertising injury which may arise from any of the operations under the Contract. Coverage under this insurance shall be at least as broad as that provided by the latest edition of Insurance Services Office ("ISO") Form CG 0001. Such insurance shall be "occurrence" based rather than "claims-made." No Commercial Liability Insurance policy shall contain exclusions that are not included in ISO Form CG 00 01 (whether by exception, exclusion, endorsement, script, or other modification) unless approved in writing by DEP, including but not limited to exclusions of any of the following attributes: (i) contractual liability insuring the contractual obligations of the insured; (ii) employer's liability coverage for liability assumed by the Contractor under an "insured contract"; (iii) coverage for claims arising under New York Labor Law; (iv) independent contractors; (v) explosion, collapse and underground (XCU); and

(vi) the applicability of Commercial General Liability Insurance coverage to the City, including its officials and employees, as Additional Insured in respect of liability arising out of claims against the Additional Insured by employees of Contractor. Such insurance shall contain a "per project" aggregate limit, as specified above, that applies separately to operations under the Contract. Such Commercial General Liability Insurance shall name the City as an Additional Insured. Coverage for the City shall specifically include the City's officials and employees, be at least as broad as the latest edition of ISO Form CG 20 10 (for the Contractor) or 20 26 (for the Town) and provide completed operations coverage at least as broad as the latest edition of ISO Form CG 20 37. ISO Form CG 20 37 shall be maintained at least three years after completion of the Contract work. Additional insured endorsements provided by any entity other than the Town of Newburgh shall not include a privity of contract requirement.

**Section 4     Commercial Automobile Liability:**

(a) The Contractor will provide Commercial Automobile Liability Insurance covering liability arising out of ownership, maintenance or use of any owned (if any), non-owned and hired vehicles to be used in connection with the Contract. Coverage shall be at least as broad as the latest edition of ISO Form CA0001.

(b) If vehicles are used for transporting hazardous materials, the Commercial Automobile Liability Insurance shall be endorsed to provide pollution liability broadened coverage for covered vehicles (endorsement CA 99 48) as well as proof of MCS 90.

**Section 5     Professional Liability Insurance**

(a) If professional services are provided pursuant to the Contract, the Contractor shall maintain and submit evidence of Professional Liability Insurance appropriate to the type(s) of such services to be provided under the Contract in the amount of at least One Million Dollars (\$1,000,000) per claim. The policy or policies shall cover the liability assumed by the Contractor under the Contract arising out of the negligent performance of professional services or caused by an error, omission or negligent act of the Contractor or anyone employed by the Contractor.

(b) All subcontractors of the Contractor providing professional services under the Contractor for which Professional Liability Insurance is reasonably commercially available shall also maintain Professional Liability Insurance in the amount of at least One Million Dollars (\$1,000,000) per claim, and the Contractor shall provide to DEP, at the time of its request for subcontractor approval, evidence of such Professional Liability Insurance on forms acceptable to DEP.

(c) Claims-made policies will be accepted for Professional Liability Insurance. All such policies shall have an extended reporting period option or automatic coverage of not less than two (2) years. If available as an option, the Contractor shall purchase extended reporting period coverage effective on cancellation or termination of such insurance unless a new policy is secured with a retroactive date, including at least the last policy year.

**Section 6**     Builders Risk Insurance:

The Town or its construction contractor shall procure and maintain Builders Risk Insurance on special causes of loss and completed value forms through completion of construction. Unless waived by DEP, such insurance shall include coverage, without limitation, for terrorism, windstorm (including named windstorm), water (other than flood-related), storm surge, and earth movement. It shall include coverage for collapse in the course of construction and ordinance and law, including coverage for loss to the undamaged portion of the building, demolition cost coverage, and increased cost of construction coverage. Such insurance shall cover, without limitation, (a) all buildings and/or structures involved in the Contract work, as well as temporary structures at the work site, and (b) any property that is intended to become permanent part of such building or structure, whether such property is on the work site, in transit or in temporary storage. Policies shall name the Town and/or its construction contractor as Named Insured and list the City as both an Additional Insured and a Loss Payee as its interest may appear.

**Section 7**     Miscellaneous Requirements for Insurance Coverage and Policies

(a) All required insurance policies shall be procured from companies that may lawfully issue such policies and have an A.M. Best rating of at least A- /VII, Standard & Poor's rating of at least A, a Fitch Ratings rating of at least A-, a Moody's Investors Service rating of at least A3, or a similar rating by any other nationally recognized statistical rating organization acceptable to the Office of the New York City Corporation Counsel, unless prior written approval is obtained from the Office of the New York City Corporation Counsel.

(b) All insurance policies (except professional liability insurance, workers' compensation/employer's liability insurance, and disability benefits insurance) shall be primary (and non-contributing) to any insurance or self-insurance maintained by the City.

(c) The Contractor shall be solely responsible for the payment of all premiums for all required insurance policies and all deductibles or self-insured retentions to which such policies are subject, whether or not the City is an insured under the policy.

(d) There shall be no self-insurance program with regard to any insurance required under this Agreement unless approved in writing by DEP. Any such self-insurance program shall provide the City, including its officials and employees, with all rights that would be provided by traditional insurance required under this Exhibit C, including, but not limited to, the defense obligations that insurers are required to undertake in liability policies.

(e) The City's limits of coverage for all types of insurance required under this Agreement shall be the greater of (i) the minimum limits set forth above in this Exhibit C or (ii) the limits provided to the Contractor as Named Insured under all primary, excess, and umbrella policies of that type of coverage.

(f) The Contractor may satisfy its insurance obligations under this Agreement through primary policies or a combination of primary and excess/umbrella policies, so long as all policies provide the scope of coverage required herein.

(g) Unless waived by DEP, policies of insurance provided pursuant to this Agreement, other than professional liability insurance and disability benefits insurance include a waiver of the right of subrogation with respect to the City of New York, including its officials and employees.

**Section 8** Proof of Insurance

(a) For all types of insurance required by this Agreement, the Contractor shall file proof of insurance in accordance with this Section 8 within ten (10) days of award of the Contract.

(b) For policies provided pursuant to Sections 1 and 2, above, the Contractor shall submit one of the following forms: C-105.2 Certificate of Workers' Compensation Insurance; U-26.3 - State Insurance Fund Certificate of Workers' Compensation Insurance; Request for WC/DB Exemption (Form CE-200); equivalent or successor forms used by the New York State Workers' Compensation Board; or other proof of insurance in a form acceptable to DEP. ACORD forms are not acceptable.

(c) For policies provided pursuant to all of this Exhibit C other than Sections 1 and 2, above, the Contractor shall submit one or more Certificates of Insurance on forms acceptable to DEP. All such Certificates of Insurance shall certify (a) the issuance and effectiveness of such policies of insurance, each with the specified minimum limits (b) for insurance secured pursuant to Section 3, that the City is an Additional Insured with coverage at least as broad as the most recent edition of ISO Forms CG 20 10 or CG 20 26, and CG 20 37, as applicable; (c) the company code issued to the insurance company by the National Association of Insurance Commissioners (the NAIC number); and (d) the number assigned to this Agreement by the City. All such Certificates of Insurance shall be accompanied by either a duly executed "Certification by Broker or Agent" in the form contained in this Exhibit C or copies of all policies referenced in such Certificate of Insurance as certified by an authorized representative of the issuing insurance carrier. If any policy is not available at the time of submission, certified binders may be submitted until such time as the policy is available, at which time a certified copy of the policy shall be submitted.

(d) Documentation confirming renewals of insurance shall be submitted to DEP prior to the expiration date of coverage of policies required under the Contract. Such proofs of insurance shall comply with the requirements of subsections (b) and (c), immediately above.

(e) The Contractor shall be obligated to provide the City with a copy of any policy of insurance provided pursuant to this Agreement upon the demand for such policy by DEP or the Office of the New York City Corporation Counsel.

**Section 9** Operations of the Contractor:

(a) The Contractor shall not commence the Contract work unless and until all required certificates have been submitted to and accepted by DEP. Acceptance of a certificate does not excuse the Contractor from securing insurance consistent with all provisions of the Contract or of any liability arising from its failure to do so.

(b) The Contractor shall be responsible for providing continuous insurance coverage in the manner, form, and limits required by the Contract and shall be authorized to perform Contract work only during the effective period of all required coverage.

(c) In the event that any of the required insurance policies lapse, are revoked, suspended or otherwise terminated, for whatever cause, the Contractor shall immediately stop all Contract work, and shall not recommence work until authorized in writing to do so. Contract time shall continue to run during such periods and no extensions of time will be granted. The Contractor may be declared to be in default for failure to maintain required insurance.

(d) In the event the Contractor receives notice, from an insurance company or other person, that any insurance policy required under this Exhibit C shall be cancelled or terminated (or has been cancelled or terminated) for any reason, the Contractor shall immediately forward a copy of such notice to DEP and (if the Contractor in question is the Town itself) to the New York City Comptroller, Attn: Office of Contract Administration, Municipal Building, One Centre Street, Room 1005, New York, New York 10007. Notwithstanding the foregoing, the Contractor shall ensure that there is no interruption in any of the insurance coverage required under this Exhibit C.

(e) Whenever notice of loss, damage, occurrence, accident, claim or suit to an insurance company is required under a policy maintained in accordance with this Exhibit C (whether on behalf of the Contractor as Named Insured or the City as Additional Insured), the Contractor shall provide timely notice thereof. Such notice shall comply with all of the following requirements:

- (i) The Contractor shall send written notice of any such event to all insurance carriers that issued potentially responsive policies (including commercial general liability insurance carriers for events relating to the Contractor's own employees) no later than twenty (20) days after such event and again no later than twenty (20) days after the initiation of any claim and/or suit resulting therefrom. Such notice shall contain the following information: the number of the insurance policy, the name of the Named Insured, the date and location of the incident, and the identity of the persons injured or property damaged. For any policy on which the City is an Additional Insured and/or Loss Payee, such notice shall expressly specify that "this notice is being given on behalf of the City of New York as Additional Insured [and Loss Payee, as applicable], as well as the Named Insured."
- (ii) Whenever such notice is sent under a policy on which the City is an Additional Insured, the Contractor shall provide copies of the notice to the Comptroller, DEP and the City Corporation Counsel. The copy to the Comptroller shall be sent to the Insurance Unit, NYC Comptroller's Office, 1 Centre Street – Room 1222, New York, New York 10007. The copy to DEP shall be sent to the address set forth at the beginning of this Exhibit C. The copy to the City Corporation Counsel shall be sent to Insurance Claims Specialist, Affirmative

Litigation Division, New York City Law Department, 100 Church Street, New York, New York 10007.

- (iii) If the Contractor fails to provide any of the foregoing notices to any appropriate insurance carrier(s) in a timely and complete manner, the Contractor shall indemnify the City for all losses, judgments, settlements, and expenses, including reasonable attorneys' fees, arising from an insurer's disclaimer of coverage citing late notice by or on behalf of the City.

## **CERTIFICATES OF INSURANCE**

### **Instructions to New York City Agencies, Departments, and Offices**

All certificates of insurance (except certificates of insurance solely evidencing Workers' Compensation Insurance, Employer's Liability Insurance, and/or Disability Benefits Insurance) must be accompanied by one of the following:

(1) the Certification by Insurance Broker or Agent on the following page setting forth the required information and signatures;

-- OR --

(2) copies of all policies as certified by an authorized representative of the issuing insurance carrier that are referenced in such certificate of insurance. If any policy is not available at the time of submission, certified binders may be submitted until such time as the policy is available, at which time a certified copy of the policy shall be submitted.

**CITY OF NEW YORK  
CERTIFICATION BY INSURANCE BROKER OR AGENT**

The undersigned insurance broker or agent represents to the City of New York that the attached Certificate of Insurance is accurate in all material respects.

\_\_\_\_\_  
[Name of broker or agent (typewritten)]

\_\_\_\_\_  
[Address of broker or agent (typewritten)]

\_\_\_\_\_  
[Email address of broker or agent (typewritten)]

\_\_\_\_\_  
[Phone number/Fax number of broker or agent (typewritten)]

\_\_\_\_\_  
[Signature of authorized official, broker, or agent]

\_\_\_\_\_  
[Name and title of authorized official, broker, or agent (typewritten)]

Sworn to before me this

\_\_\_\_\_ day of \_\_\_\_\_, 201\_

\_\_\_\_\_  
NOTARY PUBLIC



# PROCLAMATION

## ***2019 HALLOWEEN CURFEW***

The Town of Newburgh is concerned with the safety and welfare of our children along with protection of private property.

I hereby proclaim a Town Wide Curfew on door to door "Trick or Treating" and other outdoors Halloween related activities.

The curfew will run from 9:00 pm until 6:00 am starting on Tuesday October 29<sup>th</sup> through Thursday October 31<sup>st</sup> 2019

I am requesting that parents inform their children and supervise the implementation of the Town Wide Curfew so that we may avoid problems and for the safety, health and welfare of our Town's young people and property owners.

Given Under My Hand and Seal  
This 15th Day of October 2019

Gil Piaquadio Supervisor  
Town of Newburgh  
County of Orange  
State of New York

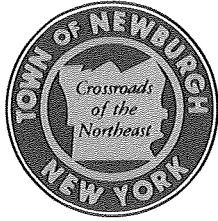

## TOWN OF NEWBURGH

1496 Route 300, Newburgh, New York 12550

11A  
and  
11B

PERSONNEL DEPT.

PH: 845-566-7785  
Fax: 845-564-2170

To: Gilbert Piaquadio, Supervisor  
Town Board

From: Charlene M Black, Personnel

Date: October 2, 2019

Re: Clerk to Town Justice

---

Judge Clarino has a vacancy created by Jennifer Profpe's resignation. He would like to hire Abigail Puntar as his Clerk to Town Justice. Upon approval from the Town Board, Ms. Puntar will need to complete her paperwork, physical and fingerprints. She will be part of the management division. A hire date of October 16, 2019 is proposed. Thank you

in advance.



**TOWN OF NEWBURGH JUSTICE COURT**  
**311 ROUTE 32**  
**NEWBURGH, NEW YORK 12550**

**TELEPHONE (845) 564-7161**  
**FACSIMILE (845) 564-7171**

**HON. RICHARD CLARINO**  
**TOWN JUSTICE**

September 24, 2019

Hon. Gilbert Piaquadio  
Supervisor of the Town of Newburgh  
1496 Route 300  
Newburgh, New York 12550

Charlene Black  
Director of Personnel  
1496 Route 300  
Newburgh, New York 12550

Re: Recommendation to Fill Vacancy for Court Clerk to Town Justice

Dear Supervisor Piaquadio and Ms. Black:

This is to request that Abigail Puntar be appointed to fill the position of Court Clerk to Town Justice. Enclosed is Ms. Puntar's resume.

Please contact me if you have any questions or wish to discuss this matter further.

Very truly yours,

**RICHARD CLARINO**  
Town Justice, Town of Newburgh

cc: James Presutti

# TOWN OF NEWBURGH

## EMPLOYMENT REQUEST FORM

**To: Personnel Department**

NAME OF CANDIDATE: Abigail Punter

DEPARTMENT: Justice Court

TITLE OF POSITION: Court Clerk to Town Justice

FULL TIME OR PART TIME: Full Time

HOURLY RATE: 22.<sup>00</sup>

IS POSITION FUNDED IN CURRENT BUDGET:  YES OR NO

FUND APPROPRIATION NUMBER: 1110.001

PROPOSED HIRE DATE: October 16 2019

NOTE: CANDIDATE CANNOT BEGIN WORK WITHOUT FINGERPRINTS, PRE-EMPLOYMENT PHYSICAL,  
DRUG/ALCOHOL TESTING AND COMPLETION OF ALL REQUIRED PAPERWORK

**RICHARD CLARINO**  
TOWN JUSTICE-TOWN OF NEWBURGH

  
DEPARTMENT HEAD SIGNATURE

9/27/19  
DATE

**ORIGINAL APPLICATION SHOULD BE ON FILE IN THE PERSONNEL  
DEPARTMENT**



12

TOWN OF NEWBURGH ANIMAL CONTROL &  
SHELTER

645 GIDNEY AVE. NEWBURGH, NY 12550

(845)561-3344  
FAX: (845) 561-2220

To: Town Board

From: Cheryl Cunningham, Animal Control

Subject: Authorization to pay Vet Services Utilizing T-94 Account

Date: October 4, 2019

---

I am requesting authorization to use the T-94 account to pay for Vet service: Newburgh Vet

Totaling: \$2348.60

Feline: \$1584.15

Canine: \$764.45

# COPY

## TOWN OF NEWBURGH

1496 Route 300  
Newburgh, New York 12550  
(845) 564-4552

DEPARTMENT \_\_\_\_\_

CLAIMANT'S  
NAME  
AND  
ADDRESS

**NEWBURGH VETERINARY HOSPITAL**  
17-6 Route 300  
Newburgh, NY 12550  
Tel: (845) 564-2660  
www.newburghvet.com

TERMS Net 30 Days

DO NOT WRITE IN THIS BOX

Date Voucher Received		VOUCHER NO. _____
FUND - APPROPRIATION	AMOUNT	
Total		
Abstract #		

Invoice # \_\_\_\_\_

Feline

Dates	Quantity	Description of Materials or Services	Unit Price	Amount
8/25/19	716834 ①			33.00
8/29/19	717242 ②			81.73
9/13/19	719104 ③		99.75	103.25
9/15/19	717617 ④			48.50
9/15/19	717618 ⑤		\$132.28	132.28
9/10/19	718032 ⑥		68.50	99.00
9/17/19	718722 ⑦			72.00
9/18/19	718799 ⑧			153.75
9/18/19	718802 ⑨			12.73
9/18/19	718805 ⑩		854.91	854.41
<b>TOTAL</b>				<b>1590.65</b>

① ✓  
② ✓  
③ ✓  
④ ✓  
⑤ ✓  
⑥ ✓  
⑦ ✓  
⑧ ✓  
⑨ ✓  
⑩ ✓

1584.15

### CLAIMANT'S CERTIFICATION

I, Dora McCatt certify that the above account in the amount of \$ 1584.15 is true and correct; that the items, services and disbursements charged were rendered to or for the municipality on the dates stated; that no part has been paid or satisfied; that taxes from which the municipality is exempt, are not included; and that the amount claimed is actually due.

10/2/19 DATE                      Dora McCatt SIGNATURE                      ORice Mar TITLE

(Space below for municipal use)

### DEPARTMENT APPROVAL

The above services or materials were rendered or furnished to the municipality on the dates stated and the charges are correct.

\_\_\_\_\_ Date                      Authorized Official

### APPROVAL FOR PAYMENT

This claim is approved and ordered for paid from the appropriations indicated above

\_\_\_\_\_ Date                      Auditing Board

# INVOICE

## Newburgh Veterinary Hospital

1716 Route 300  
Newburgh, NY 12550  
845 564-2660



"Your pet is part of our family too." Visit us at [www.newburghvet.com](http://www.newburghvet.com)

**FOR:** Town of Newburgh - Feline  
645 Gidney Ave.  
Newburgh, NY 12550  
(845) 561-3344

**Printed:** 10-03-19 at 1:41p

**Date:** 08-25-19

**Account:** 4417

**Invoice:** 716834

Date	For	Qty	Description	Price	Discount	Net Price
------	-----	-----	-------------	-------	----------	-----------

08-25-19	Jewel 29C 19	1	FELINE RHINO/PANLEUK/CALICI	31.00	17.25	13.75 ** ✓
	Your pet has been immunized against feline distemper, rhinotracheitis, and calicivirus. Occasionally listlessness, lethargy, or lack of appetite may occur. If severe listlessness or facial swelling occurs, please call us for advice.					

08-25-19		1	Feline Rabies/ Purevax 1yr	40.50	21.25	19.25 ** ✓
	Today, your cat received the most advanced rabies protection available. PUREVAX Rabies vaccine gives your cat protection that is pure, safe and effective without the use of potentially harmful adjuvants.					

---

Total charges, this invoice... 33.00

\*\*Total discount included: 38.50

Your invoice total reflects our **13Stray Cat Accounts** discount.

---

LIKE US ON FACEBOOK.COM!

GOING AWAY?...BOOK YOUR PETS BOARDING RESERVATION TODAY!

In compliance with New York State law, all medications are non-refundable. We regret any inconveniences.

# INVOICE

## Newburgh Veterinary Hospital

1716 Route 300  
Newburgh, NY 12550  
845 564-2660

"Your pet is part of our family too." Visit us at [www.newburghvet.com](http://www.newburghvet.com)



**FOR:** Town of Newburgh - Feline  
645 Gidney Ave.  
Newburgh, NY 12550  
(845) 561-3344

**Printed:** 08-29-19 at 2:25p  
**Date:** 08-29-19  
**Account:** 4417  
**Invoice:** 717242

Date	For	Qty	Description	Price	Discount	Net Price
08-27-19	Herman 35k-19	1	CONSULT / EXAM - Sick	69.50	38.25	31.25 ** ✓
08-27-19		1	Pet Insurance Review			0.00
			Please visit <a href="http://www.petinsurancereview.com">www.petinsurancereview.com</a> and <a href="http://dogtime.com">dogtime.com</a> for an independent review of all national pet health insurance plans			
08-27-19		1	FeLV/FIV ELISA in hosp	120.00	71.50	48.50 ** ✓
08-27-19		15	Panacur Dewormer Liquid / ml #26	25.80	23.82	1.98 ** ✓
08-27-19		1	Recommend-Fecal (please dropoff			0.00
			Annual fecal microscopic exams are very important for the health of your pet and, since some worms are transmissible to humans, for the health of your family. Please bring us your pet's fecal sample at your earliest convenience			
08-27-19		1	Zoonoses			0.00
			Discussed Zoonotic potential of intestinal parasites- in particular roundworms.			
08-27-19		1	Recommend- Monthly Flea and Tic			0.00
Total charges, this invoice...						81.73
**Total discount included: 133.57						

Your invoice total reflects our **13Stray Cat Accounts** discount.

Reminders for: **Herman 35k-19** (Weight: 0.7 lbs - 8w) Last done

06/24	Consultation/Exam- Bi-annual
12/19	FECAL EXAM
11/19	Rabies/Purevax Feline 1yr
11/19	Neuter your pet at 5-6 months
08/19	Feline Rhino/Panleuk/Calici #

**Herman 35k-19's weight history** (in lbs)

08-27-19	0.70
----------	------



# INVOICE

## Newburgh Veterinary Hospital

1716 Route 300  
Newburgh, NY 12550  
845 564-2660

③

"Your pet is part of our family too." Visit us at [www.newburghvet.com](http://www.newburghvet.com)

**FOR:** Town of Newburgh - Feline  
645 Gidney Ave.  
Newburgh, NY 12550  
(845) 561-3344

**Printed:** 10-03-19 at 1:42p  
**Date:** 09-03-19  
**Account:** 4417  
**Invoice:** 719104

Date	For	Qty	Description	Price	Discount	Net Price
09-03-19	Smitten 37K-19	1	CONSULT / EXAM - Sick	69.50	38.25	31.25 **
09-03-19		1	Pet Insurance Review			0.00
Please visit <a href="http://www.petinsurancereview.com">www.petinsurancereview.com</a> and <a href="http://dogtime.com">dogtime.com</a> for an independent review of all national pet health insurance plans						
09-03-19		1	Shelter euthanasia and body care f			<del>72.00</del> 168.50
09-03-19		0.20	TelazolInject Control Log / ml			0.00
09-03-19		1	Euthanasia - Somlethol Pent Contr			0.00

Total charges, this invoice...  
\*\*Total discount included: 38.25

~~103.25~~  
99.75

Your invoice total reflects our **13Stray Cat Accounts** discount.

LIKE US ON FACEBOOK.COM!

GOING AWAY?...BOOK YOUR PETS BOARDING RESERVATION TODAY!

In compliance with New York State law, all medications are non-refundable. We regret any inconveniences.

# INVOICE

## Newburgh Veterinary Hospital

1716 Route 300  
Newburgh, NY 12550  
845 564-2660

"Your pet is part of our family too." Visit us at [www.newburghvet.com](http://www.newburghvet.com)

**FOR:** Town of Newburgh - Feline  
645 Gidney Ave.  
Newburgh, NY 12550  
(845) 561-3344

**Printed:** 09-05-19 at 2:09p  
**Date:** 09-05-19  
**Account:** 4417  
**Invoice:** 717617

Date	For	Qty	Description	Price	Discount	Net Price
09-01-19	Kitten 36k-19	1	FeLV/FIV ELISA in hosp	120.00	60.00	<del>60.00</del> **
09-01-19		1	FeLV/FIV ELISA in hosp	120.00	120.00	0.00 **

Total charges, this invoice...  
\*\*Total discount included: 180.00

44.50  
~~60.00~~  
44.50

Your invoice total reflects our **13Stray Cat Accounts** discount.

Reminders for: <b>Kitten 36k-19</b>	Last done
07/24	Consultation/Exam- Bi-annual
01/20	FECAL EXAM
11/19	Rabies/Purevax Feline 1yr
08/19	Feline Rhino/Panleuk/Calici #

LIKE US ON FACEBOOK.COM!

GOING AWAY?...BOOK YOUR PETS BOARDING RESERVATION TODAY!

In compliance with New York State law, all medications are non-refundable. We regret any inconveniences.

# INVOICE

## Newburgh Veterinary Hospital

1716 Route 300  
Newburgh, NY 12550  
845 564-2660

5

"Your pet is part of our family too." Visit us at [www.newburghvet.com](http://www.newburghvet.com)

**FOR:** Town of Newburgh - Feline  
645 Gidney Ave.  
Newburgh, NY 12550  
(845) 561-3344

**Printed:** 09-05-19 at 2:11p  
**Date:** 09-05-19  
**Account:** 4417  
**Invoice:** 717618

Date	For	Qty	Description	Price	Discount	Net Price
09-05-19	Donut 12K-19	1	Weight Monitoring			0.00
09-05-19		0.10	BuprenorphineSR Inject/ml in hosp	37.30	37.30	0.00 **
09-05-19		0.26	Convenia Inject / ml Hosp	44.17	22.09	22.08 ✓
09-05-19		0.26	Onsior Inject/ ml (hosp)	33.40	16.70	16.70 ✓
09-05-19		0.04	TelazolInject Control Log / ml			0.00
09-05-19		1	OHE FELINE	180.00	100.25	79.75 ✓

Your pet has been spayed. This eliminates the risk of uterine infection and lowers the risk of breast tumors when she gets older. Expect her to be quiet and not as active for a couple of days. Restrict exercise for the next two weeks. This receipt certifies that your pet has been spayed. Please keep this with your pet's health records.

09-05-19		1	-Isoflurane Gas Anesthesia			0.00
09-05-19		1	PEDICURE	15.00	15.00	0.00 **
09-05-19		1	FELINE RHINO/PANLEUK/CALICI	31.00	17.75	13.25 **

Your pet has been immunized against feline distemper, rhinotracheitis, and calicivirus. Occasionally listlessness, lethargy, or lack of appetite may occur. If severe listlessness or facial swelling occurs, please call us for advice.

13.75

Total charges, this invoice...

~~131.78~~

\*\*Total discount included: 209.09

132.28

Your invoice total reflects our **13Stray Cat Accounts** discount.

Reminders for: Donut 12K-19 (Weight: 5.7 lbs - 5m)	Last done
03/24 Consultation/Exam- Bi-annual	
09/20 Feline Rhino/Panleuk/Calici I/	
07/20 Rabies/Purevax Feline 1yr	07-09-19
09/19 FECAL EXAM	

### Doctor's Instructions

OHE FELINE

# INVOICE

## Newburgh Veterinary Hospital

1716 Route 300  
Newburgh, NY 12550  
845 564-2660

6

"Your pet is part of our family too." Visit us at [www.newburghvet.com](http://www.newburghvet.com)

**FOR:** Town of Newburgh - Feline  
645 Gidney Ave.  
Newburgh, NY 12550  
(845) 561-3344

**Printed:** 09-10-19 at 1:43p  
**Date:** 09-10-19  
**Account:** 4417  
**Invoice:** 718032

Date	For	Qty	Description	Price	Discount	Net Price
09-10-19	20k-19 Mischief	1	OHE FELINE Your pet has been spayed. This eliminates the risk of uterine infection and lowers the risk of breast tumors when she gets older. Expect her to be quiet and not as active for a couple of days. Restrict exercise for the next two weeks. This receipt certifies that your pet has been spayed. Please keep this with your pet's health records.	180.00	100.25	79.75 ** ✓
09-10-19		1	-Isoflurane Gas Anesthesia			0.00
09-10-19		0.05	BuprenorphineSR Inject/ml in hosp	33.65	33.65	0.00 **
09-10-19		0.20	Penicillin G Inject / ml (in hosp)	30.13	30.13	0.00 **
09-10-19		0.07	TelazolInject Control Log / ml			0.00
09-10-19		1	Feline Rabies/ Purevax 1yr Today, your cat received the most advanced rabies protection available. PUREVAX Rabies vaccine gives your cat protection that is pure, safe and effective without the use of potentially harmful adjuvants.	40.50	21.25	19.25 ** ✓

Total charges, this invoice... 99.00

\*\*Total discount included: 185.28

Your invoice total reflects our **13Stray Cat Accounts** discount.

Reminders for: 20k-19 Mischief	Last done
03/24 Consultation/Exam- Bi-annual	
09/20 Rabies/Purevax Feline 1yr	09-10-19
09/19 FECAL EXAM	
07/19 Rhinotracheitis/Pan/leuk/Calic	

### Doctor's Instructions

#### OHE FELINE

Your kitty has been surgically spayed. Please watch the incision for swelling or redness, and give antibiotics as indicated.

# INVOICE

## Newburgh Veterinary Hospital

1716 Route 300  
Newburgh, NY 12550  
845 564-2660



"Your pet is part of our family too." Visit us at [www.newburghvet.com](http://www.newburghvet.com)

**FOR:** Town of Newburgh - Feline  
645 Gidney Ave.  
Newburgh, NY 12550  
(845) 561-3344

**Printed:** 10-03-19 at 1:43p  
**Date:** 09-17-19  
**Account:** 4417  
**Invoice:** 718722

Date	For	Qty	Description	Price	Discount	Net Price
09-10-19	River 38C-19	1	Shelter euthanasia and body care f			72.00
09-10-19		0.15	TelazolInject Control Log / ml			0.00
09-10-19		2	Euthanasia - Somlethol Pent Contr			0.00
Total charges, this invoice...						<del>72.00</del>

64.50

LIKE US ON FACEBOOK.COM!

GOING AWAY?...BOOK YOUR PETS BOARDING RESERVATION TODAY!

In compliance with New York State law, all medications are non-refundable. We regret any inconveniences.

# INVOICE

## Newburgh Veterinary Hospital

1716 Route 300  
Newburgh, NY 12550  
845 564-2660



"Ycur pet is part of our family too." Visit us at [www.newburghvet.com](http://www.newburghvet.com)

**FOR:** Town of Newburgh - Feline  
645 Gidney Ave.  
Newburgh, NY 12550  
(845) 561-3344

**Printed:** 09-18-19 at 1:26p  
**Date:** 09-18-19  
**Account:** 4417  
**Invoice:** 718799

Date	For	Qty	Description	Price	Discount	Net Price
09-18-19	Siren 26k-19	0.15	BuprenorphineSR Inject/ml in hosp	40.95	40.95	0.00 **
09-18-19		0.35	Penicillin G Inject / ml (in hosp)	30.23	30.23	0.00 **
09-18-19		0.06	TelazolInject Control Log / ml			0.00
09-18-19		1	OHE FELINE	180.00	100.25	79.75 ** ✓
Your pet has been spayed. This eliminates the risk of uterine infection and lowers the risk of breast tumors when she gets older. Expect her to be quiet and not as active for a couple of days. Restrict excercise for the next two weeks. This receipt certifies that your pet has been spayed. Please keep this with your pet's health records.						
09-18-19		1	-Isoflurane Gas Anesthesia			0.00
09-18-19		1	Feline Rabies/ Purevax 1yr	40.50	21.25	19.25 ** ✓
Today, your cat received the most advanced rabies protection available.PUREVAX Rabies vaccine gives your cat protection that is pure, safe and effective without the use of potentially harmful adjuvants.						
09-18-19		1	FELINE RHINO/PANLEUK/CALICI	31.00	17.25	13.75 ** ✓
Your pet has been immunized against feline distemper, rhinotracheitis, and calicivirus. Occasionally listlessness, lethargy, or lack of appetite may occur. If severe listlessness or facial swelling occurs, please call us for advice.						
09-18-19		1	FeLV/ FIV Elisa SA260	94.00	53.00	41.00 ** ✓
09-18-19		1	Weight Monitoring			0.00
Total charges, this invoice...						153.75
**Total discount included: 262.93						

Your invoice total reflects our **13Stray Cat Accounts** discount.

Reminders for:	Siren 26k-19 (Weight: 7.0 lbs - 18w)	Last done
05/24	Consultation/Exam- Bi-annual	
09/20	Feline Rhino/Panleuk/Calici I/	
09/20	Rabies/Purevax Feline 1yr	09-18-19

# INVOICE

## Newburgh Veterinary Hospital

1716 Route 300  
Newburgh, NY 12550  
845 564-2660



"Your pet is part of our family too." Visit us at [www.newburghvet.com](http://www.newburghvet.com)

**FOR:** Town of Newburgh - Feline  
645 Gidney Ave.  
Newburgh, NY 12550  
(845) 561-3344

**Printed:** 09-18-19 at 1:58p  
**Date:** 09-18-19  
**Account:** 4417  
**Invoice:** 718802

Date	For	Qty	Description	Price	Discount	Net Price
09-18-19	Siren 26k-19	1	Frontline Gold Feline Single	20.00	7.27	12.73

Total charges, this invoice... 12.73

\*\*Total discount included: 7.27

Your invoice total reflects our **13Stray Cat Accounts** discount.

Reminders for: **Siren 26k-19** (Weight: 7.0 lbs - 18w) Last done

05/24	Consultation/Exam- Bi-annual	
09/20	Feline Rhino/Panleuk/Calici I/	
09/20	Rabies/Purevax Feline 1yr	09-18-19
11/19	FECAL EXAM	

**Siren 26k-19's weight history** (in lbs)

09-18-19	7.00
----------	------

LIKE US ON FACEBOOK.COM!

GOING AWAY?...BOOK YOUR PETS BOARDING RESERVATION TODAY!

In compliance with New York State law, all medications are non-refundable. We regret any inconveniences.

# INVOICE

## Newburgh Veterinary Hospital

1716 Route 300  
Newburgh, NY 12550  
845 564-2660

10

"Your pet is part of our family too." Visit us at [www.newburghvet.com](http://www.newburghvet.com)

**FOR:** Town of Newburgh - Feline  
645 Gidney Ave.  
Newburgh, NY 12550  
(845) 561-3344

**Printed:** 09-18-19 at 6:32p  
**Date:** 09-18-19  
**Account:** 4417  
**Invoice:** 718805

Date	For	Qty	Description	Price	Discount	Net Price	
09-17-19	Winston 24K - 1	1	Leg Amputation	880.00	440.00	440.00	** ✓
09-17-19		1	NEUTER FELINE	94.50	52.50	42.00	** ✓
09-17-19		1	Anesthesia- Isoflurane	260.00	130.00	130.00	** ✓
09-17-19		1	-I.V.Cath. /subcut fluids during surg	88.50	44.25	44.25	** ✓
09-17-19		1	---BloodPressureMonitoring w/anes			0.00	
09-17-19		1	---PulseOximeterMonitoring w/Ane			0.00	
09-17-19		1	-CapnographMonitoring w/Anesthe			0.00	
09-17-19		1	----Recovery in Heated Cage			0.00	
09-17-19		1	----Warm Water Blanket in Surgery			0.00	
09-17-19		0.15	BuprenorphineSR Inject/ml outpati	40.65	20.33	20.32	** ✓
09-17-19		0.22	Convenia(Cefovecin) Inject/ml Out	28.55	14.27	14.28	** ✓
09-17-19		0.20	Onsior Inject/ ml (outpatient)	20.17	10.09	10.08	** ✓
09-17-19		0.20	Onsior Inject/ ml (outpatient)	20.17	10.09	10.08	** ✓
09-17-19		0.04	TelazolInject Control Log / ml			0.00	
09-17-19		1	Feline Rabies/ Purevax 1yr	40.50	21.25	19.25	** ✓
<p>Today, your cat received the most advanced rabies protection available. PUREVAX Rabies vaccine gives your cat protection that is pure, safe and effective without the use of potentially harmful adjuvants.</p>							
09-17-19		1	PEDICURE	15.00	15.00	0.00	**
09-17-19		1	FELINE RHINO/PANLEUK/CALICI	31.00	17.75	13.25	**
<p>Your pet has been immunized against feline distemper, rhinotracheitis, and calicivirus. Occasionally listlessness, lethargy, or lack of appetite may occur. If severe listlessness or facial swelling occurs, please call us for advice.</p>							
09-17-19		1	Hospitalization+Dr.Care Cat/Day	75.50	37.75	37.75	** ✓
09-17-19		1	OSHA Compliance Biohazards Fee	7.00	3.50	3.50	** ✓
09-17-19		2	Nursing/ General/day	53.00	26.50	26.50	** ✓
09-17-19		2	Daily Feeding	12.00	6.00	6.00	** ✓
09-18-19		0.10	BuprenorphineSR Inject/ml in hosp	37.30	18.65	18.65	** ✓
09-18-19		1	Rehab Laser Therapy	37.00	18.50	18.50	** ✓

0.00 \*\*  
13.25 \*\*  
13.75

Total charges, this invoice...

\*\*Total discount included: 886.43

854.41  
851.91

Your invoice total reflects our **13 Stray Cat Accounts** discount.



# COPY

## TOWN OF NEWBURGH

1496 Route 300  
Newburgh, New York 12550  
(845) 564-4552

DEPARTMENT \_\_\_\_\_

CLAIMANT'S  
NAME  
AND  
ADDRESS

**NEWBURGH VETERINARY HOSPITAL**  
17 6 Route 300  
Newburgh, NY 12550  
Tel: (845) 564-2660  
www.newburghvet.com

TERMS Net 30 Days

DO NOT WRITE IN THIS BOX

Date Voucher Received		VOUCHER NO. _____
FUND - APPROPRIATION	AMOUNT	
Total		
Abstract #		

Invoice # \_\_\_\_\_

Canine

Dates	Quantity	Description of Materials or Services	Unit Price	Amount
10/27/19	717020 ①			227.95
10/29/19	717219 ①			188.14
10/29/19	718001 ③		298.748	824.99
11/11/19	718167 ②			33.12
11/22/19	719099 ⑤			16.50
			<b>TOTAL</b>	<b>764.45</b>
				<b>790.70</b>

Out  
Out  
③ 4  
⑤ 4

### CLAIMANT'S CERTIFICATION

Dora M Cast

I, Dora M Cast certify that the above account in the amount of \$ 764.45 is true and correct; that the items, services and disbursements charged were rendered to or for the municipality on the dates stated; that no part has been paid or satisfied; that taxes, from which the municipality is exempt, are not included; and that the amount claimed is actually due.

10/22/19  
DATE

Dora M Cast  
SIGNATURE

Office Manager  
TITLE

(Space below for municipal use)

### DEPARTMENT APPROVAL

The above services or materials were rendered or furnished to the municipality on the dates stated and the charges are correct.

Date \_\_\_\_\_

Authorized Official \_\_\_\_\_

### APPROVAL FOR PAYMENT

This claim is approved and ordered for paid from the appropriations indicated above

Date \_\_\_\_\_

Auditing Board \_\_\_\_\_

# INVOICE

## Newburgh Veterinary Hospital

1716 Route 300  
Newburgh, NY 12550  
845 564-2660



"Your pet is part of our family too." Visit us at [www.newburghvet.com](http://www.newburghvet.com)

**FOR:** Town of Newburgh - canine  
645 Gidney Ave  
Newburgh, NY 12550  
(845) 561-3344

**Printed:** 10-02-19 at 9:20a  
**Date:** 08-27-19  
**Account:** 19984  
**Invoice:** 717020

Date	For	Qty	Description	Price	Discount	Net Price	
08-27-19	Cher 45-19	1	Lyme,Hwt,Ehrlich Anaplasma 4Dx i	110.00	69.75	40.25	** ✓
08-27-19		1	OHE Canine - Town of Newburgh			99.75	✓
08-27-19		1	Anesthesia- Isoflurane	260.00	260.00	0.00	**
08-27-19		1	---BloodPressureMonitoring w/anes			0.00	
08-27-19		1	---PulseOximeterMonitoring w/Ane			0.00	
08-27-19		1	-CapnographMonitoring w/Anesthe			0.00	
08-27-19		1	-----Recovery in Heated Cage			0.00	
08-27-19		1	----Warm Water Blanket in Surgery			0.00	
08-27-19		1	Canine Respiratory Complex- Bord	37.00	23.25	13.75	** ✓
<p>Canine Kennel Cough is A HIGHLY contagious respiratory infection. Dogs can be exposed at any time through coughing or nose to nose contact. Boarding, grooming and or showing dogs can have increased risk of exposure....please be sure to have your pet boosted every 12 months.</p>							
08-27-19		1	CANINE RABIES / 1YEAR	38.00	21.50	16.50	** ✓
08-27-19		1	Canine Dist/A2/PI/Parvo/Lepto1YR	39.00	24.50	14.50	** ✓
<p>Your pet has been vaccinated with Pfizer's new 5 in 1 DA2PPI , the best available protection against Distemper,Adenovirus, Parvovirus, Parainfluenza,and Leptosiprosis</p>							
08-27-19		0.50	Hydromorphone 2mg/ml Inject/ml	35.55	35.55	0.00	**
08-27-19		1.80	Penicillin G Inject / ml Outpatient	31.04	31.04	0.00	**
08-27-19		2	Vetprofen Tablets 25mg Individual	18.81	18.81	0.00	**
08-27-19		0.35	TelazolInject Control Log / ml			0.00	
08-27-19		60	Doxycycline Hyclate Tablets 100m	59.55	16.35	43.20	** ✓
08-27-19		1	Veterinarian's Notes			0.00	

Total charges, this invoice... 227.95

\*\*Total discount included: 500.75

Your invoice total reflects our **13Stray Cat Accounts** discount.

LIKE US ON FACEBOOK.COM!

# INVOICE

## Newburgh Veterinary Hospital

1716 Route 300  
Newburgh, NY 12550  
845 564-2660



"Your pet is part of our family too." Visit us at [www.newburghvet.com](http://www.newburghvet.com)

**FOR:** Town of Newburgh - canine  
645 Gidney Ave  
Newburgh, NY 12550  
(845) 561-3344

**Printed:** 08-29-19 at 2:06p  
**Date:** 08-29-19  
**Account:** 19984  
**Invoice:** 717219

Date	For	Qty	Description	Price	Discount	Net Price
08-29-19	Dandyllion 66-19	1	CONSULT / EXAM - Sick	69.50	38.25	31.25 ** ✓
08-29-19		1	Pet Insurance Review			0.00
Please visit <a href="http://www.petinsurancereview.com">www.petinsurancereview.com</a> and <a href="http://dogtime.com">dogtime.com</a> for an independent review of all national pet health insurance plans						
08-29-19		1	Capstar Blue 11.4 mg 2-25 #			7.02 ✓
08-29-19		1	Antirobe AquaDrops (25mg/ml) #26	33.15	23.79	9.36 ** ✓
08-29-19		1	Metacam Oral Susp 15ml (0.5mg/m	49.50	25.74	23.76 ** ✓
08-29-19		1	CANINE RABIES / 1YEAR	38.00	21.50	16.50 ** ✓
08-29-19		1	Canine Dist/A2/PI/Parvo/1YR	39.00	24.50	14.50 ** ✓
Your pet has been vaccinated with Pfizer's new 5 in 1 DA2PPI, the best available protection against Distemper, Adenovirus, Parvovirus, Parainfluenza, and Leptospirosis						
08-29-19		1	Canine Respiratory Complex- Bord	37.00	23.25	13.75 ** ✓
Canine Kennel Cough is A HIGHLY contagious respiratory infection. Dogs can be exposed at any time through coughing or nose to nose contact. Boarding, grooming and or showing dogs can have increased risk of exposure....please be sure to have your pet boosted every 12 months.						
08-29-19		1	Accuplex4 Lyme, HW, Ehrlichia, Ana	72.00	46.00	26.00 ** ✓
08-29-19		1	Pre-Anesth Chem <7yrs SA040	92.00	46.00	46.00 ** ✓
<b>Total charges, this invoice...</b>						188.14
**Total discount included: 249.03						

Your invoice total reflects our **13 Stray Cat Accounts** discount.

Reminders for: <b>Dandyllion 66-19</b>	Last done
08/22 Consultation/Exam- Bi-annual	
08/20 Lyme, HW, Ehrlichia Accu Plus4(A)	08-29-19
08/20 CANINE RABIES / 3 YEAR	
08/20 CanineDist/Aden/Para/Parvo/Lep	

# INVOICE

## Newburgh Veterinary Hospital

1716 Route 300  
Newburgh, NY 12550  
845 564-2660

(3)

"Your pet is part of our family too." Visit us at [www.newburghvet.com](http://www.newburghvet.com)

**FOR:** Town of Newburgh - canine  
645 Gidney Ave  
Newburgh, NY 12550  
(845) 561-3344

**Printed:** 09-09-19 at 6:29p  
**Date:** 09-09-19  
**Account:** 19984  
**Invoice:** 718001

Date	For	Qty	Description	Price	Discount	Net Price	
09-07-19	Percy (mange) 9	1	CONSULT / EXAM - Sick	69.50	38.25	31.25	** ✓
09-07-19		1	Pet Insurance Review			0.00	
Please visit <a href="http://www.petinsurancereview.com">www.petinsurancereview.com</a> and <a href="http://dogtime.com">dogtime.com</a> for an independent review of all national pet health insurance plans							
09-07-19		1	Shelter board medical alert k9	51.50	25.75	25.75	** ✓
09-07-19		1	Weight Monitoring			0.00	
09-07-19		1	Skin Scraping (in oil x mites) in hos	33.00	16.50	16.50	** ✓
09-07-19		1	Cytology In Hospital	70.50	35.25	35.25	** ✓
Veterinarian Interpretation +/- Consult							
09-07-19		1	Sampling + Slide Prep Fee 1	11.10	5.55	5.55	** ✓
09-07-19		1	OSHA Compliance Biohazards Fee	7.00	3.50	3.50	** ✓
09-07-19		2	Dexamethasone Inject / ml Outpati	40.20	20.10	20.10	** ✓
09-07-19		1	PEDICURE	15.00	15.00	0.00	** ✓
09-07-19		1	Nexgard 24-60lb L single	20.00	0.80	19.20	** ✓
09-07-19		28	Cephalexin 500mg capsule #26197	27.63	25.31	2.32	** ✓
09-07-19		1	Shampoo - Douxo ChlorhexPS+Cli	24.60	9.84	14.76	** ✓
09-07-19		1	Ophth- Terramycin Ointment #2619	39.00	22.80	16.20	** ✓
09-07-19		1	BATH MEDICATED 36-54#			52.50	** ✓
09-08-19		1	Optixcare Eye Lube Plus #261970	22.00	11.81	10.19	** ✓
09-08-19		1	Heartworm Test T615	52.50	26.25	26.25	** ✓
Heartworm disease is an enormous problem in our area, seen in not only outdoor but also indoor dogs. It is transmitted by mosquitos. The AVMA strongly recommends that all dogs be tested once yearly and kept on a monthly preventative year round.							
09-08-19		43	Panacur Dewormer / lb (6 Packets)	46.34	23.17	23.17	** ✓
09-09-19		1	Heartworm Elisa Negative			0.00	
09-09-19		1	Accuplex4 Lyme, HW, Ehrlichia, Ana	72.00	36.00	36.00	** ✓

Total charges, this invoice...

~~338.49~~

\*\*Total discount included: 315.88

Your invoice total reflects our **13Stray Cat Accounts** discount.

298.74

# INVOICE

## Newburgh Veterinary Hospital

1716 Route 300  
Newburgh, NY 12550  
845 564-2660

(4)

"Your pet is part of our family too." Visit us at [www.newburghvet.com](http://www.newburghvet.com)

**FOR:** Town of Newburgh - canine  
645 Gidney Ave  
Newburgh, NY 12550  
(845) 561-3344

**Printed:** 09-11-19 at 3:48p  
**Date:** 09-11-19  
**Account:** 19984  
**Invoice:** 718167

Date	For	Qty	Description	Price	Discount	Net Price	
09-11-19	Dandy Lion 66-19	1	Metacam Oral Susp 15ml (0.5mg/	49.50	25.74	23.76	** ✓
09-11-19		1	Antirobe AquaDrops (25mg/ml) #26	33.15	23.79	9.36	** ✓
Total charges, this invoice...						33.12	
**Total discount included: 49.53							

Your invoice total reflects our **13Stray Cat Accounts** discount.

LIKE US ON FACEBOOK.COM!

GOING AWAY?....BOOK YOUR PETS BOARDING RESERVATION TODAY!

In compliance with New York State law, all medications are non-refundable. We regret any inconveniences.

# INVOICE

## Newburgh Veterinary Hospital

1716 Route 300  
Newburgh, NY 12550  
845 564-2660



"Your pet is part of our family too." Visit us at [www.newburghvet.com](http://www.newburghvet.com)

**FOR:** Town of Newburgh - canine  
645 Gidney Ave  
Newburgh, NY 12550  
(845) 561-3344

**Printed:** 10-03-19 at 1:39p  
**Date:** 09-22-19  
**Account:** 19984  
**Invoice:** 719099

Date	For	Qty	Description	Price	Discount	Net Price
09-22-19	Sage	1	CANINE RABIES / 1YEAR	38.00	21.50	16.50

Total charges, this invoice... 16.50

\*\*Total discount included: 21.50

Your invoice total reflects our **13Stray Cat Accounts** discount.

Reminders for: **Sage** Last done

09/20	CANINE RABIES / 3 YEAR
03/20	Neuter your pet at 5-6 months
03/20	Canine Kennel Cough Vacc -1 ye
03/20	FECAL EXAM
09/17	<b>Consultation/Exam- Bi-annual</b>
09/13	<b>Pro-Heart 12 (26-50lbs)</b>
09/13	<b>Pro-Heart 12 (1-25lb)</b>
09/13	<b>Pro-Heart 12 (51-100lbs)</b>

LIKE US ON FACEBOOK.COM!

GOING AWAY?...BOOK YOUR PETS BOARDING RESERVATION TODAY!

In compliance with New York State law, all medications are non-refundable. We regret any inconveniences.

AGREEMENT

Made and entered into this day of \_\_\_\_\_, 2019, by and between the **TOWN OF NEWBURGH**, by and through its Town Board, with its offices located at 1496 Rt. 300, Newburgh, New York 12550, hereinafter referred to as the "**TOWN**," and **ROEMER WALLENS GOLD & MINEAUX LLP**, Labor Relations Attorneys and Consultants, with its principal place of business located at 13 Columbia Circle, Albany, New York 12207, hereinafter referred to as "**ROEMER WALLENS GOLD & MINEAUX**."

1. The **TOWN** hereby retains and employs **ROEMER WALLENS GOLD & MINEAUX** as its Labor Relations Attorneys and Consultants to provide to the **TOWN** the following professional services for the period of time hereinafter designated.

(a) Comprehensive negotiating services up to and including impasse resolution proceedings and interest arbitration as exemplified in Exhibit "A" which is attached hereto and made a part hereof for each of the following collective bargaining units in which terms and conditions of employment for the **TOWN** and its employees are negotiated:

- i) PBA Bargaining Unit
- ii) CSEA Bargaining Unit

(b) Consultations and advice regarding the **TOWN'S** rights and liabilities in connection with:

- i) Civil Service Law
- ii) Taylor law
- iii) Fair Labor Standards Act
- iv) Public Officers Law
- v) Freedom of Information Law
- vi) Unemployment Insurance Law
- vii) Workers' Compensation Law
- viii) Human Rights/Discrimination
- ix) Sexual Harassment Investigations
- x) Disability Benefits
- xi) Contract Administration and Enforcement
- xii) Grievances Filed Against Employer
- xiii) Employee Discipline Matters (Includes drafting of Notice of Discipline based upon information supplied)
- xiv) Work Rules
- xv) Layoff Procedures
- xvi) General Municipal Law
- xvii) Americans With Disabilities Act
- xviii) Family and Medical Leave Act
- xix) Omnibus Transportation Employee Testing Act of 1991 (CDL Drug Testing)
- xx) Pregnancy Discrimination Act

- xxi) Appointment of Non-Unionized Employees and related matters
  - xxii) Such other laws, rules and regulations as may apply to the field of labor relations and personnel administration
- (c) Advice and representation in connection with:
- i) Initial steps of contract grievance procedure.
  - ii) Pre-hearing matters before the Public Employment Relations Board (Improper Practice Charges, Managerial/Confidential Petitions, and Union representation challenges), including the preparation of pleadings (other than documents prepared in lieu of a hearing) and attendance at all pre-hearing conferences. Hearing preparation and settlement negotiations which lead to a settlement without a hearing are covered by paragraph 2 below.
  - iii) Attendance at relevant Labor/Management meetings and meetings of the Legislative body and committees thereof.
- (d) Management and Supervisory Training in connection with employee corrective action, contract administration and other topics agreed upon by the parties in an amount not to exceed two (2) days per calendar year.
- (e) Periodic printed reports containing relevant information regarding public sector labor relations as obtained from Public Employment Relations Board decisions, New York State Court decisions, relevant Administrative agency decisions and other similar sources.

2. **ROEMER WALLENS GOLD & MINEAUX** hereby agrees that it will provide the **TOWN**, as requested by the **TOWN**, with those services not specifically covered by this Agreement, such as document preparation, negotiating settlements of disciplinary matters, grievances and other matters upon request, representation at the final step in administrative disciplinary proceedings against employees, representation at the final step in contract grievance proceedings, representation at hearings before the Public Employment Relations Board, including the preparation of documents prepared in lieu of a hearing, hearing preparation and settlement negotiations, as well as representation in labor related litigation in New York and Federal Courts at the following rates:

- Partner and Senior Associate Attorney  
In year 2020, the hourly rate will be \$250.00.
- Associate Attorney  
In year 2020, the hourly rate will be \$210.00.
- Paralegal  
In year 2020, the hourly rate will be \$140.00.



The foregoing includes disbursements such as postage for letters, in-house photocopy costs, local telephone charges and faxes. The foregoing shall be exclusive of normal disbursements paid by the firm on behalf of the **TOWN**, such as court filing fees, computer research, consultants, appraisers, arbitration panel selection fees, out-of-office copy charges, express delivery charges and the like.

3. The **TOWN** and **ROEMER WALLENS GOLD & MINEAUX** agree that those representatives of **ROEMER WALLENS GOLD & MINEAUX** who perform services pursuant to this Agreement shall be approved in advance by the **TOWN**.

4. That in consideration of the foregoing, the **TOWN** hereby agrees to compensate **ROEMER WALLENS GOLD & MINEAUX** (inclusive of normal disbursements) as follows:

- Three Thousand Three Hundred Dollars (\$3,300.00) per month from January 1, 2020 through December 31, 2020.

The Town may have the right to arbitrate fee disputes under Part 137 of the Rules of the Chief Administrator.

5. In accordance with our records retention policy, we will maintain all documents, papers and other items relating to our representation of you pursuant to this retainer agreement (the "Records") for a period of four (4) years from the date we cease providing you with legal services hereunder. If you desire to maintain the Records beyond that date, you will need to retain your own copies or request the Records in writing before the end of the four (4) year period. After that time, all of the Records will be destroyed.

6. The term of this Agreement shall be from January 1, 2020 through December 31, 2020. The **TOWN** may terminate this Agreement earlier than December 31, 2020, upon thirty (30) days' written notice from the **TOWN** to **ROEMER WALLENS GOLD & MINEAUX**.

IN WITNESS WHEREOF, the parties have executed this Agreement on the day and year first written above.

**TOWN OF NEWBURGH**

By: \_\_\_\_\_  
Gil Piaquadio, Supervisor

**ROEMER WALLENS GOLD & MINEAUX LLP**

By: Elayne G. Gold 9/1/19  
Elayne G. Gold, Partner

## EXHIBIT "A"

### NEGOTIATION SERVICES

#### A. Preparation for Negotiations

The need for thorough preparation prior to the commencement of actual bargaining is often overlooked. We believe that preparation is a key element in assuring a successful outcome to the negotiation process.

Preparation includes:

- Reviewing the existing contract and offering advice regarding suggested modifications
- Reviewing the existing work rules and practices
- Reviewing grievances filed and arbitration decisions
- Reviewing the demands presented by both Union and Management in the last negotiations
- Reviewing the history of other benefit changes over the past six years
- Reviewing the most recent settlements in similarly situated jurisdictions
- Meeting with first line supervisors to ascertain their needs - both changes to the existing contract, as well as the needed additions to the contract
- Meeting with senior officials to determine their needs and review the findings resulting from meetings with line supervisors

#### B. Preparation of Demands

This phase of the process is flexible and is adapted to the needs of each jurisdiction. Generally, we recommend that Labor Counsel prepare suggested demands and that those demands be reviewed by you and modified to suit your needs.

#### C. Selection of Negotiating Team

We recommend that a cross-section of management representatives be appointed to the negotiating team so that the entire negotiating process can be "felt" at all levels of management. Managers appreciate the process to a much greater degree if they know and trust those who were directly involved.

#### **D. Participation in Negotiations**

The negotiations are made much easier by careful planning and research as typified in "A", "B", and "C" above. We will participate fully in all phases of negotiations including renegotiation preparatory sessions, face-to-face meetings at the bargaining table, management caucuses, and, if necessary, the impasse process. We will maintain a detailed record of the negotiations for use in future proceedings. Our services include representation through the impasse procedure.

#### **E. Communications**

Meetings with key management personnel will be scheduled throughout the negotiating process to inform them of progress in the negotiations and to recommend position modifications.

#### **F. Drafting the Contract**

All changes agreed upon in the negotiations process will be reduced to contract language which accurately reflects the agreement and is readily understood by Union and Management representatives, as well as those important persons not present at the bargaining table such as arbitrators.

#### **G. Ratification**

After a tentative agreement has been entered into, it must be presented to and approved by the appropriate Legislative body. We will appear before such body and make all necessary presentations to explain the proposed agreement.

#### **H. Conduct Management Information Sessions**

At the conclusion of negotiations it is extremely important that all changes be identified and explained to supervisors and managers. General information on reasons for the changes or failure to achieve desired changes must be explained so that managers are fully supportive of the new contract.



# HIGHWAY DEPARTMENT

14

90 GARDNERTOWN ROAD  
NEWBURGH, NEW YORK 12550

TELEPHONE 845-561-2177  
FAX 845-561-8987

MARK HALL  
HIGHWAY SUPERINTENDENT

**TO:** Gil Piaquadio, Supervisor & Town Board Members  
**FROM:** Mark Hall, Highway Superintendent *MH*  
**DATE:** October 1, 2019  
**RE:** Fall Leaf and Brush Pick-up

I would like to get the approval to have the attached letter published in the local newspapers to inform the Town Residents of the Fall pick-up schedule. Pick-up will be for the week of November 18, 2019 to November 21, 2019 and November 22, 2019 for calls.

If you have any questions you may feel free to contact me in my office.

**MH/ch**  
**cc:** Joseph P. Pedi, Town Clerk



## **TOWN OF NEWBURGH RESIDENTS LEAF AND BRUSH PICKUP – FALL OF 2019**

Town trucks will pick up bagged leaves and brush (which must be less than 4 inches in diameter & no longer than four (4) feet in length & tied in bundles). Leaves will be in CLEAR BAGS ONLY BY ORDER OF TOWN BOARD. CLEAR BAGS are available at many retail outlets & stores in the Greater Newburgh area. Leaves bagged with DIRT AND STONE mixed in will NOT be picked up. Bags of Grass Clippings, Pine Cones or Pine Needles will NOT be picked up. Town trucks will not return to any area once they have picked up in the area.

**Leaves & Brush must be curbside  
throughout the entire Town on Monday,  
November 18, 2019 no later than 7:00A.M.**

**We wish to THANK YOU for your cooperation**

A leaf and brush recycling bin is available to the public at the Town of Newburgh Highway Department at 90 Gardnertown Road, Newburgh. Hours are Monday thru Friday 7:00am to 3:00pm.

Elizabeth J. Greene, Councilwoman  
James F. Presutti, Councilman

Gil Piagnadio, Supervisor

Scott M. Manley, Councilman  
Paul I. Ruggiero, Councilman

**BY ORDER OF THE TOWN BOARD, Joseph P. Pedi, Town Clerk**



Town of Newburgh  
1496 Route 300  
Newburgh, New York 12550  
(845) 564-4552

Date: 9/23/19

Is the budget adjustment under \$5,000? Yes: \_\_\_\_\_ No: X

If yes: Please give Gil a copy to sign and deliver to the Accounting Office.

If no: Please have the board approve at the next available board meeting.

Reason why the budget transfer is needed to cover the cost of larger size meters, so that the Department can continue with the meter change out program.

From: Account Number: 8340-5200 Amount: 10,000.00  
Account Description: Equipment Amount: \_\_\_\_\_

From: Account Number: \_\_\_\_\_ Amount: \_\_\_\_\_  
Account Description: \_\_\_\_\_ Amount: \_\_\_\_\_

To: Account Number: 834-5466 Amount: 10,000.00  
Account Description: Operating Supplies Amount: \_\_\_\_\_

To: Account Number: \_\_\_\_\_ Amount: \_\_\_\_\_  
Account Description: \_\_\_\_\_ Amount: \_\_\_\_\_

Please note: The total of the from and to should equal.

[Signature]  
Department Head Signature

\_\_\_\_\_  
Gil Piaquadio, Town Supervisor



# TOWN OF NEWBURGH

16

1496 Route 300, Newburgh, New York 12550

**RONALD E. CLUM, CPA**  
ACCOUNTANT

845-564-5220  
Fax: 845-566-9461  
E-Mail: rclumaccountant@townofnewburgh.org

**To:** Gil Piaquadio, Town Supervisor and  
Town Board  
**CC:** Mark Hall, Fleet Department  
**From:** Ronald E. Clum, Town Accountant  
**Date:** October 1, 2019  
**RE:** Budget Adjustment

Could you approve the following budget transfer that is needed to cover the purchase of the Snap-On Diagnostic Scanner for the fleet department.

Since this requires Board action could you add this to the next board meeting.

<u>FROM ACCOUNT</u>	<u>TO ACCOUNT</u>	<u>AMOUNT</u>
A.1990.5499 Contingency	A.1640.5200 Fleet Department - Equipment	\$13,092.00

Sincerely,

Ronald E. Clum

\_\_\_\_\_  
Board Approval



## TOWN OF NEWBURGH

1496 Route 300, Newburgh, New York 12550

17

PERSONNEL DEPT.

PH: 845-566-7785  
Fax: 845-564-2170

To: Supervisor Piaquadio ✓  
Town Board  
Cc: Ron Clum, Accountant  
From: Charlene M Black, Personnel  
Date: September 27, 2019  
Re: Extension of EAP Contract

---

Please see the attached letter from Catholic Charities who administer our EAP program. They are unfortunately increasing their fee by \$97.00 for a total contract cost of \$5487.00 for 2019-2020 contract. This is the first increase since the inception of the program in 2014. Mr. Piaquadio will need to sign the extension per the letter attached. Please approve this so we can go forward with the EAP program, since it is part of our handbook and the union contracts. Many of our employees have been utilizing the program. Thank you in advance.





Corporate Services EAP  
305 North Street  
Middletown, NY 10940  
Tel: 845.344.5565  
Fax: 845.344.6982

September 23, 2019

Charlene Black  
Personnel Director  
Town of Newburgh  
1496 Route 300  
Newburgh, NY 12550

Dear Charlene:

Enclosed is Addendum No.5 extending the EAP agreement between Town of Newburgh and Corporate Services EAP for another year. If the addendum meets with your approval, please have both originals signed and returned to me. I will forward a fully executed original to you for your file.

Also enclosed is the invoice for the first quarter of the current contract year, August 15, 2019 – November 14, 2019. While we try to contain costs, please note that we have increased our annual fee slightly by \$97 in order to cover our own increasing business expenses. This is the first increase since the inception of our agreement in 2014. The current number of employees covered under the EAP is 220, with an annual fee of \$5,487.00.

This invoice will be followed by our annual "year in review" information. We forward our invoice separately and prior to the report in order to maintain consistency in the billing cycle. We appreciate your patience with this process.

Please give me a call if you have any questions or concerns.

Sincerely,

Pat Hollenbeck  
Contract Manager

Encls.

October 15h Town Board Meeting Agenda Item

Building and Grounds 21 Hudson Plaza

I am looking for a motion to award D-Ben Securities Inc. of Newburgh New York the installation of the Security System at 21 Hudson Plaza for a total of \$ 25,290.62

I am looking for a motion to award D-Ben Securities Inc. of Newburgh New York the cost of the 2<sup>nd</sup> year guarantee on all security systems at 21 Hudson Plaza for a total of \$ 2100.00

A handwritten signature in black ink, appearing to be "M. L.", enclosed within a large, loopy oval shape.

# TOWN OF NEWBURGH

*Crossroads of the Northeast*

OLD TOWN HALL  
308 GARDNERTOWN ROAD  
NEWBURGH, NEW YORK 12550

CODE COMPLIANCE DEPT.  
TELEPHONE 845-564-7801  
FAX LINE 845-564-7802

To: Supervisor Gil Piaquadio

September 27, 2019

From: Gerald Canfield Code Compliance Supervisor 

Re: Price Quote Burgler, Fire and Camera System

21 Hudson Valley Professional Plaza

Plans and specifications have been sent to the listed below vendors upon request as advertised in the legal notice which appeared in both the Mid Hudson Times and the Orange County Post . Per the legal notice, a mandatory walk through at the site was scheduled for September 19<sup>th</sup> at 10:00am. One vendor appeared which is D-Ben Security Inc. One Price quote was received at the Town Clerks Office for opening for the advertised date of Thursday September 26<sup>th</sup>. From D-Ben Security Inc.

Henri Bradshaw

John Delgado

D-Ben Securities Inc.

Construct Connect

A.V.S. Technology

91 Thompson St.

3825 Edwards Rd.

140 J Commerce Rd.

Newburgh N.Y.

Cincinatti Oho

Totowa N.J.

12550

45209

07512

**Quote Sheet for Security Systems 21 Hudson Plaza Newburgh, New York 12550**

**Quotes should be returned in a sealed envelope clearly marked "Quote for Security Systems Hudson Plaza" and delivered to Town Clerk Joseph Pediti 1496 Route 300 Newburgh, N.Y. 12550. Quotes will be opened on September 26<sup>th</sup> 2019 at 10:00 am.**

This work is subject to Prevailing Wage.

Systems must be complete thirty calendar days (30) from award date by Town of Newburgh.

Systems must be guaranteed for one year after completion and acceptance of the systems by the Town of Newburgh.

Please supply three (3) references of similar installations completed by your company.

Two hours of training shall be included in this quote.

All systems to be in plenum cable of 16/2 gauge. Wiring to be concealed or placed in steel wiremold.

All security equipment is Honeywell, Fire Lite, System Sensor ADEMCO or equal, Video system is Dahua or equal. Proprietary systems only offered to limited dealers will not be acceptable.

Proof of Liability Insurance \$ 1,000,000 each occurrence with a \$ 2,000,000 total with the town being named as also insured, Workers Compensation and Automobile insurance must be supplied before commencement of any work.

Cost for installation of fire and burglar system including pre wire:

\_\_\_\_\_ \$ 1,268,91

Cost for pre wire of fire and burglar system:

\_\_\_\_\_ \$ 232,00

Cost for installation of video system including pre wire:

\_\_\_\_\_ \$ 7968.71

Cost for pre wire of Video system:

\_\_\_\_\_ \$ 232,00

Cost for 2<sup>nd</sup> year guarantee on all systems:

\_\_\_\_\_ \$ 2100,00



**From** D-BEN Security Systems, Inc.

91 Thompson Street  
Newburgh NY 12550  
(845)565-4024

**Quote No.** 0889801

**Quote For** Town of Newburgh

Type Service Call  
Prepared By Gregory DeBenedictus  
Created On 08/05/2019  
Valid Until 10/31/2019

Town of Newburgh -  
Hudson Plaza  
21 Hudson Valley  
Professional Plaza  
Newburgh NY 12550

## Description of Work

Installation of a Burglar and Fire Alarm System

Partition for Animal Control

Partition for Code Compliance

## Services to be completed

[Alarm Systems] Location - Building

Installation of a Burglar and Fire Alarm System

Parts, labor, and fees	Quantity	Unit Price	Total
Honeywell 128 Zone Commercial Burg/Fire Control	1	\$640.79	\$640.79
Honeywell Commercial Fire Keypad Red	1	\$219.62	\$219.62
Honeywell 6160PX Custom Alpha Prox Keypad	2	\$201.55	\$403.10
Honeywell Ultra Wireless Commercial Receiver	1	\$244.64	\$244.64
Honeywell wireless Smoke Detector	33	\$92.16	\$3,041.28
Honeywell Wireless Heat Detector	4	\$77.76	\$311.04
Pull Station	7	\$50.96	\$356.72
Commercial Wireless Transmitter	7	\$97.92	\$685.44
Horn/Strobe	7	\$74.76	\$523.32
Honeywell Mini Wireless Contact	4	\$51.62	\$206.48
Honeywell Wireless Motion Detector	4	\$89.28	\$357.12
16/2 Solid FPLP Red 1000'	1	\$177.92	\$177.92
Prevailing Wage Labor Rate	1	\$5,000.00	\$5,000.00
		<b>GRAND TOTAL</b>	<b>\$12,681.91</b>

<b>Parts, labor, and fees</b>	<b>Quantity</b>	<b>Unit Price</b>	<b>Total</b>
Strobe	3	\$53.40	\$160.20
Honeywell Wireless CO Detector	3	\$118.08	\$354.24
		<b>GRAND TOTAL</b>	<b>\$12,681.91</b>

By my signature below, I authorize work to begin and agree to pay the Grand Total.

Name: \_\_\_\_\_ Date: \_\_\_\_\_

Signature: \_\_\_\_\_

**Photos**

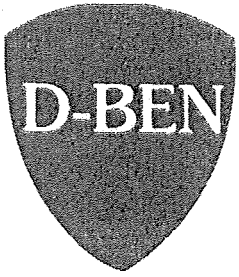

**From** D-BEN Security Systems,  
Inc.

91 Thompson Street  
Newburgh NY 12550  
(845)565-4024

**Quote No.** 0889842

**Quote For** Town of Newburgh

Type Installation  
Prepared By Gregory DeBenedictus  
Created On 08/05/2019  
Valid Until 10/31/2019

Town of Newburgh -  
Hudson Plaza  
21 Hudson Valley  
Professional Plaza  
Newburgh NY 12550

## Description of Work

Installation of a IP based Camera System

## Services to be completed

[CCTV] Location - Building

Installation of a IP based Camera System

Parts, labor, and fees	Quantity	Unit Price	Total
Dahua 4K 16CH 1U NVR	1	\$829.46	\$829.46
Skyhawk 3.5 4TB Hard Drive	2	\$186.26	\$372.52
Dahua 4MP IR Vari-focal ePoE Bullet	4	\$269.65	\$1,078.60
Dahua Junction Box	4	\$40.79	\$163.16
Ip Over Coax Passive Converters	4	\$100.79	\$403.16
Dahua 1/3" 4MP MOS, 0.08LUX/F2.0 Ip Camera	4	\$145.95	\$583.80
Wbox 43" 4k UHD Tv	1	\$319.70	\$319.70
Category 6 ECO Cable Plenum White	1	\$318.31	\$318.31
Prevailing Wage Labor Rate	1	\$3,900.00	\$3,900.00
		<b>GRAND TOTAL</b>	<b>\$7,968.71</b>

By my signature below, I authorize work to begin and agree to pay the Grand Total.

Name: \_\_\_\_\_ Date: \_\_\_\_\_

Signature: \_\_\_\_\_



**21 Hudson Plaza Security System equipment list:**

If a conflict in the number of detectors exists between the floor plans and equipment schedule Equipment list will take precedent.

**FIRE ALARM**

- 1 Honeywell 128 Zone Commercial Burg/Fire Control
- 1 Honeywell Commercial Fire Keypad Red
- 2 Honeywell 6160X Custom Alpha Prox Keypad
- 1 Honeywell Ultra Wireless Commercial Receiver
- 33 Wireless Smoke Detector
- 4 Honeywell Wireless Heat Detector
- 7 Pull Stations
- 5 Commercial Wireless Transmitter
- 7 Horn/Strobe
- 5 Strobes
- 7 Heat Detectors
- 3 Wireless CO Detectors

**BURGLAR ALARM SYSTEM**

- 4 Honeywell Mini Wireless Contact
- 4 Honeywell Wireless Motion Detector

**IP CAMERA SYSTEM**

- 1 Dahua 4K 16CH 1U NVR
- 2 Skyhawk 3.5 4TB Hard Drive
- 4 Dahua 4MP IR Vari-focal ePoE Bullet
- 4 Dahua Junction Box
- 4 Ip Over Coax Passive Converters
- 4 Dahua 1/3" 4MP MOS,0.08LUX/F2.0 Ip Camera
- 1 42" Full HD 1920x1080 LED Monitor

# BG-12 Series

## Manual Fire Alarm Pull Stations

 **FIRE-LITE ALARMS**  
by Honeywell

Conventional Initiating Devices

### General

The Fire-Lite **BG-12 Series** is a cost-effective, feature-packed series of non-coded manual fire alarm pull stations. It was designed to meet multiple applications with the installer and end-user in mind. The BG-12 Series features a variety of models including single- and dual-action versions.

The BG-12 Series provides Fire-Lite Alarm Control Panels (FACPs), as well as other manufacturers' controls, with a manual alarm initiating input signal. Its innovative design, durable construction, and multiple mounting options make the BG-12 Series simple to install, maintain, and operate.

### Features

- Aesthetically pleasing, highly visible design and color.
- Attractive contoured shape and light textured finish.
- Meets ADA 5 lb. maximum pull-force.
- Meets UL 38, Standard for Manually Actuated Signaling Boxes.
- Easily operated (single- or dual-action), yet designed to prevent false alarms when bumped, shaken, or jarred.
- PUSH IN/PULL DOWN handle latches in the down position to clearly indicate the station has been operated.
- The word "ACTIVATED" appears on top of the handle in bright yellow, further indicating operation of the station.
- Operation handle features white arrows showing basic operation direction for non-English-speaking persons.
- Braille text included on finger-hold area of operation handle and across top of handle.
- Multiple hex- and key-lock models available.
- U.S. patented hex-lock needs only a quarter-turn to lock/unlock.
- Station can be opened for inspection and maintenance without initiating an alarm.
- Product ID label viewable by simply opening the cover; label is made of a durable long-life material.
- The words "NORMAL" and "ACTIVATED" are molded into the plastic adjacent to the alarm switch (located inside).
- Four-position terminal strip molded into backplate.
- Terminal strip includes Phillips combination-head captive 8/32 screws for easy connection to Initiating Device Circuit (IDC).
- Terminal screws backed-out at factory and shipped ready to accept field wiring (up to 12 AWG/3.1 mm<sup>2</sup>).
- Terminal numbers are molded into the backplate, eliminating the need for labels.
- Switch contacts are normally open.
- Can be surface-mounted (with **SB-10** or **SB-I/O**) or semi-flush mounted. Semi-flush mount to a standard single-gang, double-gang, or 4" (10.16 cm) square electrical box.
- Backplate is large enough to overlap a single-gang backbox cutout by 1/2" (1.27 cm).
- Optional trim ring (**BG12TR**).
- Spanish versions (*FUEGO*) available (**BG-12LSP**, **BG-12LPSP**).
- Designed to replace the Fire-Lite legacy **BG-10 Series**.
- Models packaged in attractive, clear plastic (PVC), clam-shell-style, Point-of-Purchase packages. Packaging includes a cutaway dust/paint cover in shape of pull station.



### Construction

- Cover, backplate and operation handle are all molded of durable polycarbonate material.
- Cover features white lettering and trim.
- Red color matches System Sensor's popular SpectrAlert® Advance horn/strobe series.

### Operation

The BG-12 manual pull stations provide a textured finger-hold area that includes Braille text. In addition to PUSH IN and PULL DOWN text, there are arrows indicating how to operate the station, provided for non-English-speaking people.

Pushing in and then pulling down on the handle activates the normally-open alarm switch. Once latched in the down position, the word "ACTIVATED" appears at the top in bright yellow, with a portion of the handle protruding at the bottom as a visible flag. Resetting the station is simple: insert the key, twist one quarter-turn, then open the station's front cover, causing the spring-loaded operation handle to return to its original position. The alarm switch can then be reset to its normal (non-alarm) position manually (by hand) or by closing the station's front cover, which automatically resets the switch.

## Specifications

### PHYSICAL SPECIFICATIONS:

	pull station	SB-I/O	SB-10
Height	5.5 inches (13.97 cm)	5.601 inches (14.23 cm)	5.5 inches (13.97 cm)
Width	4.121 inches (10.47 cm)	4.222 inches (10.72 cm)	4.121 inches (10.47 cm)
Depth	1.39 inches (3.53 cm)	1.439 inches (3.66 cm)	1.375 inches (3.49 cm)

### ELECTRICAL SPECIFICATIONS:

Switch contact ratings: gold-plated; rating 0.25 A @ 30 VAC or VDC.

### ENGINEERING/ARCHITECTURAL SPECIFICATIONS

Manual Fire Alarm Stations shall be non-code, with a key- or hex-operated reset lock in order that they may be tested, and so designed that after actual Emergency Operation, they cannot be restored to normal except by use of a key or hex. An operated station shall automatically condition itself so as to be visually detected as activated. Manual stations shall be constructed of red colored LEXAN (or polycarbonate equivalent) with clearly visible operating instructions provided on the cover. The word FIRE shall appear on the front of the stations in white letters, 1.00 inches (2.54 cm) or larger. Stations shall be suitable for surface mounting on matching backbox SB-10 or SB-I/O; or semi-flush mounting on a standard single-gang, double-gang, or 4" (10.16 cm) square electrical box, and shall be installed within the limits defined by the Americans with Disabilities Act (ADA) or per national/local requirements. Manual Stations shall be Underwriters Laboratories listed.

**NOTE:** \*The words "FIRE/FUEGO" on the BG-12LSP shall appear on the front of the station in white letters, approximately 3/4" (1.905 cm) high.



## Agency Listings and Approvals

The listings and approvals below apply to the BG-12 Series pull stations. In some cases, certain modules may not be listed by certain approval agencies, or listing may be in process. Consult factory for latest listing status.

- C(UL)US: S711
- FM Approved
- CSFM: 7150-0075:184
- MEA: 67-02-E
- Patented: U.S. Patent No. D428,351; 6,380,846; 6,314,772; 6,632,108.

## Product Line Information

**BG-12S:** Single-action pull station with pigtail connections, hex lock.

**BG-12SL:** Same as BG-12 with key lock.

**BG-12:** Dual-action pull station with SPST N/O switch, screw terminal connections, **hex lock**.

**BG-12L:** Same as BG-12 with key lock.

**BG-12LSP:** Same as BG-12L with English/Spanish (FIRE/FUEGO) labeling.

**BG-12LOB:** Same as BG-12L with "outdoor use" listing. Includes outdoor listed backbox, and sealing gasket.

**BG-12LO:** Same as BG-12L with "outdoor use" listing. Does not include backbox.

**BG-12LA:** Same as BG-12L with auxiliary contacts.

**BG-12LPS:** Dual-action pull station with pre-signal option.

**BG-12LPSP:** Same as BG-12LPS with English/Spanish (FIRE/FUEGO) labeling.

**SB-10:** Surface-mount backbox, metal.

**SB-I/O:** Surface-mount backbox, plastic. (Included with BG-12LOB.)

**BG12TR:** Optional trim ring for semi-flush mounting.

**17003:** Keys, set of two. (Included with key-lock pull stations.)

**17007:** Hex lock, 9/64". (Included with hex-lock pull stations.)

**NOTE:** For addressable BG-12LX models, see data sheet DF-52013.

Fire-Lite® Alarms, SpectrAlert® Advance, and System Sensor® are registered trademarks of Honeywell International Inc.  
©2008 by Honeywell International Inc. All rights reserved. Unauthorized use of this document is strictly prohibited.



This document is not intended to be used for installation purposes.  
We try to keep our product information up-to-date and accurate.  
We cannot cover all specific applications or anticipate all requirements.  
All specifications are subject to change without notice.



For more information, contact Fire-Lite Alarms. Phone: (800) 627-3473, FAX: (877) 699-4105.  
www.firelite.com

## VISTA-128FBPT

VISTA® COMMERCIAL PARTITIONED FIRE AND BURGLARY ALARM CONTROL PANEL

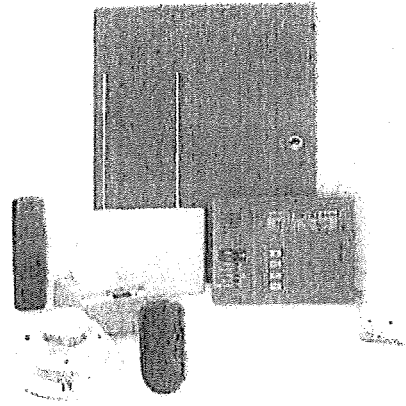

The new VISTA-128FBPT provides the ultimate protection for life and property. This commercial fire and burglary control panel supports up to eight partitions and up to 128 zones/points using hardwired, wireless and V-Plex® addressable technologies. A diverse line of Honeywell initiating devices, notification appliances, communication devices, keypads, RF receivers and relays satisfy a wide range of installation requirements.

The VISTA-128FBPT control is suitable for fire-only applications, as well as for installations requiring

integrated fire/burglary systems. It is the perfect solution for medical and professional office buildings, churches and synagogues, banks, schools, strip malls, and factory or warehouse environments.

VISTA-128FBPT is compatible with a number of AlarmNet® communication products for alarm reporting, uploading/downloading and Honeywell Total Connect™ Remote Services.

## FEATURES

- Eight hardwired zones standard, expandable to 128 using V-Plex addressable points/zones
- Supports up to 128 wireless zones (fewer if using hardwired and/or V-Plex zones)
- Can control eight separate areas independently (8 partitions)
- Common lobby partition – auto arm or disarm based upon assigned partitions
- Master partition – used for viewing status of all partitions
- Supports commercial wireless fire and burglary devices
- Stores up to 512 events
- Accommodates 150 user codes and up to 250 access card holders using VISTAKEY®
- Supports V-Plex addressable VISTAKEY access control (1 to 8 doors)
- Two on-board NACS delivering a total of 2.3A @ 12V
- Automatic smoke detector sensitivity maintenance testing
- Four-wire smoke reset using on-board Form C relay
- Supports Dynamic Signaling for AlarmNet Communicators
- Supports Internet and GSM alarm reporting
- Supports graphical user interfaces for burglary use (e.g. 6280 and Tuxedo Touch™)
- Supports 6160CR-2 multi-LED fire keypad
- Upload/download via AlarmNet® Communicators
- Carbon monoxide (CO) zone support
- On-board serial port for communication with WIN-PAK®, Pro-Watch® and approved third-party applications
- Supports Total Connect Remote Services\*
- \*Event reporting only for fire partition.

# VISTA-128FBPT

VISTA® COMMERCIAL PARTITIONED FIRE  
AND BURGLARY ALARM CONTROL PANEL

# Honeywell

## ADDITIONAL FEATURES

---

- Notification Appliance Circuits (two):
  - Programmable
  - Individually silenceable
- False alarm reduction features:
  - Exit error logic
  - Exit delay reset
  - Cross zoning
  - Call waiting defeat
  - Recent close report
- Supports commercial hardwired, addressable V-Plex® polling loop and wireless zones
- Hardwired zones
  - Provides eight style B hardwired zones
  - EOLR supervised for Fire and UL burglary installations
  - Supports N.O. or N.C. sensors
  - Individually assignable to any of eight partitions (all fire zones on partition 1)
  - Up to 16 conventional two-wire smoke detectors each on zone one and two (32 total)
- Patented addressable V-Plex polling loop technology
  - Class B, Style 3 SLC
  - Supports 120 two-wire addressable points
  - Global polling technology for faster processing
  - Supervised by panel
  - Zones individually assignable to partitions and notification circuit (bell) output or auxiliary relay
  - 4,000 ft. capability without the use of shielded cable
  - Extender/Isolation bus modules
  - Eight zone - Class A and B expander module
  - Eight zone - Class B expander module
  - Single-zone supervised contact module
  - Single relay module for auxiliary fire functions
  - Supports anti-masking feature on "smart" motion detectors (e.g. DT7500SN)
- UL Listed wireless expansion
  - Supports up to 128 wireless zones/points
  - Supervised by control for check-in signals
  - Tamper protection for transmitters
  - Individually assignable to one of eight partitions
  - Supports commercial wireless smoke detectors
- Up to eight doors using VISTAKEY® V-Plex Access Control
- Event reporting
- Local printer for event log printing
- Communication
  - Phone line, GSM and IP communicator support
  - Panel operation during download
  - Four or 10-digit subscriber account numbers
- Extra security feature that requires master code to allow installer into program mode (enabled through Compass Downloader)

## SPECIFICATIONS

---

### Electrical

- Primary power: 18VAC @ 72VA  
Honeywell No. 1451-UL9
- Control panel quiescent current draw:  
300mA
- Backup battery:
  - 12VDC, 12AH min to 34.4AH max
  - Lead acid battery (gel type)
- Alarm power: 12VDC, 1.7A max for each notification (bell) circuit output  
Total 2.3A @ 12V
- Aux. standby pwr: 12VDC, 1A max
- Total power: 2.3A at 12VDC
- Standby time: 24 hours with 1A standby load using 34.4AH battery
- Fusing: Battery input, aux. and notification (bell) circuit outputs are protected using PTC circuit protectors. All outputs are power limited.
- Optional 24-volt kit

### Communications

#### Dialer

- Line seize: Double Pole
- Ringer equiv: 0.7B
- Formats: ADEMCO Low Speed, ADEMCO 4+2 Express, ADEMCO High Speed, ADEMCO Contact ID, Sescoa and Radionics

- Dual phone line capability using 5140DLM module  
AlarmNet® Communicators
- GSM, i-GSM and IP Communicators

### Cabinet Dimensions

- 18" H x 14.5" W x 4.3"D

### Environmental

- Storage temp: 14° F to 158° F  
(-10° C to 70° C)
- Operating temp: 32° F to 122° F  
(0° C to 50° C)
- Humidity: 85% RH
- EMI: Meets or exceeds the following requirements:
  - FCC Part 15, Class B Device
  - FCC Part 68
  - IEC EMC Directive

### Agency Listings

- UL864 – Control Units and Accessories for Fire Alarm Systems
- ULC-S559-04 – Equipment for Fire Signal Receiving Centers and Systems
- UL1076 – Proprietary Burglar Alarm Units and Systems
- UL1610 – Central Station Burglar Alarm Units

- CAN/ULC-S304-06 – Signal Receiving Centre and Premise Burglar Alarm Control Units
- UL1635 – Digital Alarm Communicator System Units
- UL365 – Police Station Connected Burglar Alarm Units and Systems
- UL609 – Local Burglar Alarm Units and Systems
- UL985 – Household Fire Warning System Units
- UL1023 – Household Burglar Alarm System Units
- ULC-S545-02 – Residential Fire Warning System Control Units
- ULC/ORD-C1023-74 – Preliminary Standard for Household Burglar Alarm System Units
- ULC-S303-M91 – Standard for Local Burglar Alarm Units and Systems
- Factory Mutual (FM)
- California State Fire Marshal (CSFM)
- FDNY Certificate #6140

# VISTA-128FBPT

VISTA® COMMERCIAL PARTITIONED FIRE AND BURGLARY ALARM CONTROL PANEL

## COMPATIBLE DEVICES

### Auxiliary Devices

- 6160CR-2 – Red Fire Keypad
- 6160 – Burglary Keypad
- 6280, Tuxedo Touch™, Tuxedo Touch with Wi-Fi® Graphic Keypads – Burglary
- 4204 – Relay Module, four Form C contacts
- 4204CF – Two supervised NAC circuits
- 5881ENHC Series RF receivers
- 5883H RF receiver
- 6220S – System printer

### Two-wire Conventional Smoke Detectors

- System Sensor
- ESL
- DSC

### Horn/Strobes

- System Sensor
- Wheelock
- Gentex

### Manual Pull Stations

- 5140MPS-1
- 5140MPS-2

### V-Plex® (Addressable) Devices

- 4208U Universal Eight-zone Expansion Module
- 4208EX Universal Eight-zone Expansion Module (Canada)
- 4208SN Eight-zone Expansion Module
- 4101SN Single Relay/Zone Module
- 4208SNF Class A/B Expander Module
- 4190SN Remote Point Module – two zones
- 4193SN and 4193SNP Two-zone Expander Modules

*Product specifications subject to change.*

## ORDERING

### V128FBPT

### V128FBPT24KT (U.S. Only)

Commercial Fire and Partitioned Burglary Alarm Control Panel 12V Model

Commercial Fire and Partitioned Burglary Alarm Control Panel with External 24V Power Supply (6A, four outputs, synchronized)

For more information: [www.honeywell.com/security](http://www.honeywell.com/security)

### Automation and Control Solutions

Honeywell Security Products Americas  
2 Corporate Center Dr. Suite 100  
P.O. Box 9040  
Melville, NY 11747  
1.800.467.5875  
[www.honeywell.com](http://www.honeywell.com)

### V-Plex Extender/Isolation Modules

- 4297 Extender/Isolator Module
- VSI Isolator Module

### V-Plex Smoke Detectors

- 5193SD
- 5193SDT
- 5192SDTA

### V-Plex Passive Infrared Detectors

- IS2500SN
- DT7500SN

### V-Plex (Addressable) Contacts

- 4939SN-WH
- 4959SN

### V-Plex Glassbreak Detectors

- FG1625SN

### Seismic Detectors

- SC100
- SC105

### Commercial Wireless Devices

- 5808W3/5808W3A – Photoelectric Smoke/Heat Detector
- 5806W3 – Photoelectric Smoke Detector
- 5809 – Wireless Heat Detector
- 5817CB – Wireless Commercial Transmitter
- 5869 – Hold-Up Transmitter
- 5800CO/5800COA – Carbon Monoxide Detector
- 5800PIR-COM – Commercial PIR

### Access Control

- VISTAKEY® V-Plex® (addressable) Access Control
- VISTAKEY-SK Starter Kit
- VISTAKEY-EX Expansion Kit
- Integrates with WIN-PAK® and Pro-Watch® systems

### Alarm Communications

#### U.S.

- GSMV4G – Digital Cellular Communicator with Two-way Voice Transport Capability
- iGSMV/iGSMV4G – Internet and Digital Cellular Communicator
- iGSMCF/iGSMCFP4G – Commercial Fire Digital Cellular Communicator with Internet
- iGSMHS/iGSMHS4G – High Security Internet and Digital Cellular Communicator
- 7845i-ENT – Internet/Intranet Enterprise Communicator
- 7847i – Internet Communicator

#### Canada

- GSMV4GCN – Digital Cellular Communicator with Two-way Voice Transport Capability
- iGSMVCN/iGSMVCN4G – Internet and Digital Cellular Communicator

# Honeywell



# Indoor Selectable-Output Horns, Strobes, and Horn Strobes for Wall Applications

*System Sensor L-Series audible visible notification products are rich with features guaranteed to cut installation times and maximize profits with lower current draw and modern aesthetics.*

## Features

- Updated Modern Aesthetics
- Small profile devices for Horns and Horn Strobes
- Plug-in design with minimal intrusion into the back box
- Tamper-resistant construction
- Automatic selection of 12- or 24-volt operation at 15 and 30 candela
- Field-selectable candela settings on wall units: 15, 30, 75, 95, 110, 135, and 185
- Horn rated at 88+ dBA at 16 volts
- Rotary switch for horn tone and two volume selections
- Mounting plate for all standard and all compact wall units
- Mounting plate shorting spring checks wiring continuity before device installation
- Electrically compatible with legacy SpectrAlert and SpectrAlert Advance devices
- Compatible with MDL3 sync module
- Strobes and Horn Strobes listed for wall mounting only
- Horns listed for wall or ceiling use

FIRE

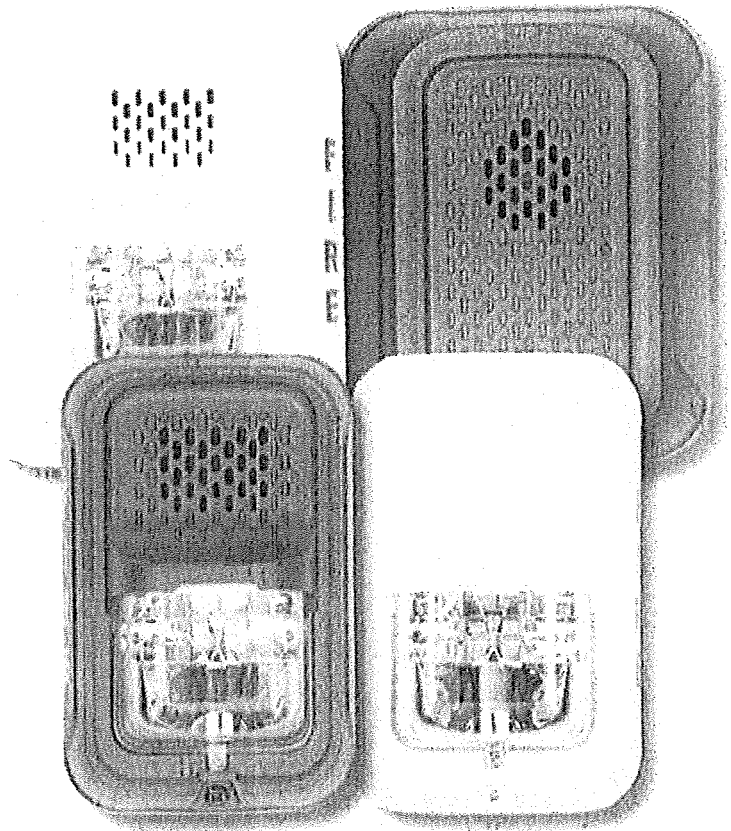

The System Sensor L-Series offers the most versatile and easy-to-use line of horns, strobes, and horn strobes in the industry with lower current draw and modern aesthetics. With white and red plastic housings, standard and compact devices, and plain, FIRE, and FUEGO-printed devices, System Sensor L-Series can meet virtually any application requirement.

The L-Series line of wall-mount horns, strobes, and horn strobes include a variety of features that increase their application versatility while simplifying installation. All devices feature plug-in designs with minimal intrusion into the back box, making installations fast and foolproof while virtually eliminating costly and time-consuming ground faults.

To further simplify installation and protect devices from construction damage, the L-Series utilizes a universal mounting plate for all models with an onboard shorting spring, so installers can test wiring continuity before the device is installed.

Installers can also easily adapt devices to suit a wide range of application requirements using field-selectable candela settings, automatic selection of 12- or 24-volt operation, and a rotary switch for horn tones with two volume selections.

## Agency Listings



FM approved class 1  
in UL512 and 515  
UL736, 248-372

UL512 and 515  
UL736, 248-372



## L-Series Specifications

### Architect/Engineer Specifications

#### General

L-Series standard horns, strobes, and horn strobes shall mount to a standard 2 x 4 x 1 7/8-inch back box, 4 x 4 x 1 1/2-inch back box, 4-inch octagon back box, or double-gang back box. L-Series compact products shall mount to a single-gang 2 x 4 x 1 7/8-inch back box. A universal mounting plate shall be used for mounting ceiling and wall products for all standard models and a separate universal mounting plate shall be used for mounting wall compact models. The notification appliance circuit wiring shall terminate at the universal mounting plate. Also, L-Series products, when used with the Sync•Circuit™ Module accessory, shall be powered from a non-coded notification appliance circuit output and shall operate on a nominal 12 or 24 volts. When used with the Sync•Circuit Module, 12-volt-rated notification appliance circuit outputs shall operate between 8.5 and 17.5 volts; 24-volt-rated notification appliance circuit outputs shall operate between 16.5 and 33 volts. Indoor L-Series products shall operate between 32 and 120 degrees Fahrenheit from a regulated DC or full-wave rectified unfiltered power supply. Strobes and horn strobes shall have field-selectable candela settings including 15, 30, 75, 95, 110, 135, and 185.

#### Strobe

The strobe shall be a System Sensor L-Series Model \_\_\_\_\_ listed to UL 1971 and shall be approved for fire protective service. The strobe shall be wired as a primary-signaling notification appliance and comply with the Americans with Disabilities Act requirements for visible signaling appliances, flashing at 1 Hz over the strobe's entire operating voltage range. The strobe light shall consist of a xenon flash tube and associated lens/reflector system.

#### Horn Strobe Combination

The horn strobe shall be a System Sensor L-Series Model \_\_\_\_\_ listed to UL 1971 and UL 464 and shall be approved for fire protective service. The horn strobe shall be wired as a primary-signaling notification appliance and comply with the Americans with Disabilities Act requirements for visible signaling appliances, flashing at 1 Hz over the strobe's entire operating voltage range. The strobe light shall consist of a xenon flash tube and associated lens/reflector system. The horn shall have two audibility options and an option to switch between a temporal three pattern and a non-temporal (continuous) pattern. These options are set by a multiple position switch. The horn on horn strobe models shall operate on a coded or non-coded power supply.

#### Synchronization Module

The module shall be a System Sensor Sync•Circuit model MDL3 listed to UL 464 and shall be approved for fire protective service. The module shall synchronize Strobes at 1 Hz and horns at temporal three. Also, while operating the strobes, the module shall silence the horns on horn strobe models over a single pair of wires. The module shall mount to a 4 1/16 x 4 1/16 x 2 1/4-inch back box. The module shall also control two Style Y (class B) circuits or one Style Z (class A) circuit. The module shall synchronize multiple zones. Daisy chaining two or more synchronization modules together will synchronize all the zones they control. The module shall not operate on a coded power supply.

### Physical/Electrical Specifications

Standard Operating Temperature	32°F to 120°F (0°C to 49°C)
Humidity Range	10 to 93% non-condensing
Strobe Flash Rate	1 flash per second
Nominal Voltage	Regulated 12 DC or regulated 24 DC/FWR <sup>1</sup>
Operating Voltage Range <sup>2</sup>	8 to 17.5 V (12 V nominal) or 16 to 33 V (24 V nominal)
Operating Voltage Range MDL3 Sync Module	8.5 to 17.5 V (12 V nominal) or 16.5 to 33 V (24 V nominal)
Input Terminal Wire Gauge	12 to 18 AWG
Wall-Mount Dimensions (including lens)	5.6" L x 4.7" W x 1.91" D (143 mm L x 119 mm W x 49 mm D)
Compact Wall-Mount Dimensions (including lens)	5.26" L x 3.46" W x 1.91" D (133 mm L x 88 mm W x 49 mm D)
Horn Dimensions	5.6" L x 4.7" W x 1.25" D (143 mm L x 119 mm W x 32 mm D)
Compact Horn Dimensions	5.25" L x 3.45" W x 1.25" D (133 mm L x 88 mm W x 32 mm D)

1. Full Wave Rectified (FWR) voltage is a non-regulated, time-varying power source that is used on some power supply and panel outputs.

2. Strobe products will operate at 12 V nominal only for 15 cd and 30 cd.

## UL Current Draw Data

UL Max. Strobe Current Draw (mA RMS)				
Candela Range	Candela	8-17.5 Volts		
		DC	DC	FWR
Candela Range	15	88	43	60
	30	143	63	83
	75	N/A	107	136
	95	N/A	121	155
	110	N/A	148	179
	135	N/A	172	209
	185	N/A	222	257

UL Max. Horn Current Draw (mA RMS)				
Sound Pattern	dB	8-17.5 Volts		
		DC	DC	FWR
Temporal	High	39	44	54
Temporal	Low	28	32	54
Non-Temporal	High	43	47	54
Non-Temporal	Low	29	32	54
3.1 KHz Temporal	High	39	41	54
3.1 KHz Temporal	Low	29	32	54
3.1 KHz Non-Temporal	High	42	43	54
3.1 KHz Non-Temporal	Low	28	29	54
Coded	High	43	47	54
3.1 KHz Coded	High	42	43	54

UL Max. Current Draw (mA RMS), Wall Horn Strobe, Candela Range (15-185 cd)									
DC Input	8-17.5 Volts			16-33 Volts					
	15cd	30cd	15cd	30cd	75cd	95cd	110cd	135cd	185cd
Temporal High	98	158	54	74	121	142	162	196	245
Temporal Low	93	154	44	65	111	133	157	184	235
Non-Temporal High	106	166	73	94	139	160	182	211	262
Non-Temporal Low	93	156	51	71	119	139	162	190	239
3.1K Temporal High	93	156	53	73	119	140	164	190	242
3.1K Temporal Low	91	154	45	66	112	133	160	185	235
3.1K Non-Temporal High	99	162	69	90	135	157	175	208	261
3.1K Non-Temporal Low	93	156	52	72	119	138	162	192	242
FWR Input	16-33 Volts								
	15cd	30cd	75cd	95cd	110cd	135cd	185cd		
Temporal High	83	107	156	177	198	234	287		
Temporal Low	68	91	145	165	185	223	271		
Non-Temporal High	111	135	185	207	230	264	316		
Non-Temporal Low	79	104	157	175	197	235	283		
3.1K Temporal High	81	105	155	177	196	234	284		
3.1K Temporal Low	68	90	145	166	186	222	276		
3.1K Non-Temporal High	104	131	177	204	230	264	326		
3.1K Non-Temporal Low	77	102	156	177	199	234	291		

## Horn Tones and Sound Output Data

Horn and Horn Strobe Output (dBA)					
Switch Position	Sound Pattern	dB	8-17.5 Volts		FWR
			DC	DC	
1	Temporal	High	84	89	89
2	Temporal	Low	75	83	83
3	Non-Temporal	High	85	90	90
4	Non-Temporal	Low	76	84	84
5	3.1 KHz Temporal	High	83	88	88
6	3.1 KHz Temporal	Low	76	82	82
7	3.1 KHz Non-Temporal	High	84	89	89
8	3.1 KHz Non-Temporal	Low	77	83	83
9*	Coded	High	85	90	90
10*	3.1 KHz Coded	High	84	89	89

\* Settings 9 and 10 are not available on 2-wire horn strobes. Temporal coding must be provided by the NAC. If the NAC voltage is held constant, the horn output remains constantly on.

## L-Series Dimensions

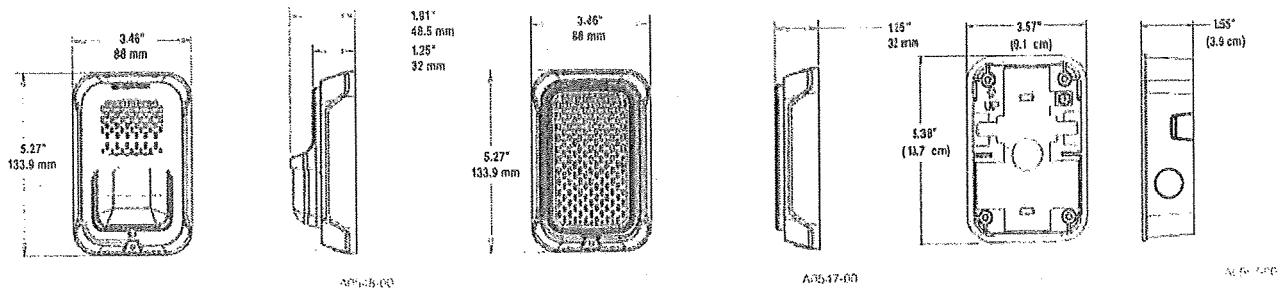

Compact Strobe, Horn Strobe

Compact Horn

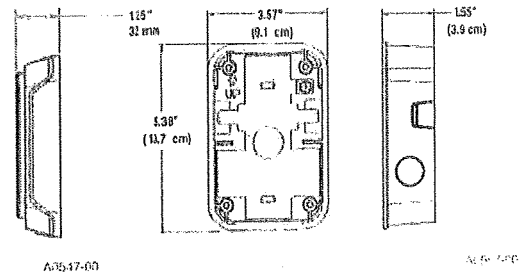

Compact Wall Surface Mount Back Box  
SBBGRL, SBBGWL

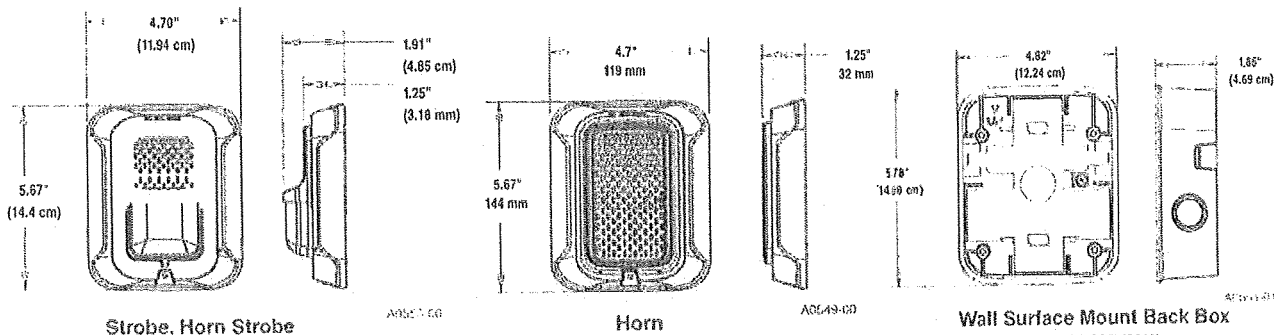

Strobe, Horn Strobe

Horn

Wall Surface Mount Back Box  
SBBRL/SBBWL

## L-Series Ordering Information

Model	Description
<b>Wall Horn Strobes</b>	
P2RL	2-Wire, Horn Strobe, Red
P2WL	2-Wire, Horn Strobe, White
P2GRL	2-Wire, Compact Horn Strobe, Red
P2GWL	2-Wire, Comp 2 fil act Horn Strobe, White
P2RL-P	2-Wire, Horn Strobe, Red, Plain
P2WL-P	2-Wire, Horn Strobe, White, Plain
P2RL-SP	2-Wire, Horn Strobe, Red, FUEGO
P2WL-SP	2-Wire, Horn Strobe, White, FUEGO
P4RL	4-Wire, Horn Strobe, Red
P4WL	4-Wire, Horn Strobe, White
<b>Wall Strobes</b>	
SRL	Strobe, Red
SWL	Strobe, White
SGRL	Compact Strobe, Red
SGWL	Compact Strobe, White
SRL-P	Strobe, Red, Plain
SWL-P	Strobe, White, Plain
SRL-SP	Strobe, Red, FUEGO
SWL-CLR-ALERT	Strobe, White, ALERT

Model	Description
<b>Horns*</b>	
HRL*	Horn, Red
HWL*	Horn, White
HGRL*	Compact Horn, Red
HGWL*	Compact Horn, White
<b>Accessories</b>	
TR-2	Universal Wall Trim Ring Red
TR-2W	Universal Wall Trim Ring White
SBBRL	Wall Surface Mount Back Box, Red
SBBWL	Wall Surface Mount Back Box, White
SBBGRL	Compact Wall Surface Mount Back Box, Red
SBBGWL	Compact Wall Surface Mount Back Box, White

### Notes:

- All -P models have a plain housing (no "FIRE" marking on cover)
- All -SP models have "FUEGO" marking on cover.
- All -ALERT models have "ALERT" marking on cover.
- \*Horn-only models are listed for wall or ceiling use.



3825 Ohio Avenue • St. Charles, IL 60174  
Phone: 800-SSENSOR2 • Fax: 630-377-6495  
www.systemsensor.com

©2018 System Sensor  
All rights reserved. No part of this publication may be reproduced, stored in a retrieval system, or transmitted, in any form or by any means, electronic, mechanical, photocopying, recording, or by any information storage and retrieval system, without the prior written permission of System Sensor.

# Wireless Products | 5800 SERIES RECEIVERS

## RECEIVERS

### ADEMCO®

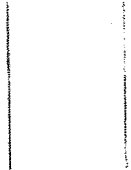

#### 5881ENL, 5881ENM, 5881ENH Receivers

- Connects to four wire keypad data lines
- Supports all 5800 Wireless Series non-bidirectional wireless devices (bidirectional devices are compatible with use of 5800TM)
- UL Listed for commercial fire applications
- Dimensions: 4-3/8" H x 7-3/8" W

**5881ENL** – up to 8 zones

**5881ENM** – up to 16 zones

**5881ENH** – unlimited zones

#### 5883H

##### High Security Transceiver Module

- Receiver and 5800TM system transmitter built-in
- Unlimited wireless zones
- Compatible with all 5800 Series wireless devices
- Supports Honeywell ADEMCO bidirectional devices: 5804BD, 5804BDV, 5828, 5828V, 5839, 5800WAVE, 5800RPL and 5800RP

Compatible with all VISTA® control panels

#### 5881ENHC

##### Commercial Wireless Receiver

- Front and back tamper for commercial fire/burglary installations
- One or two receivers can be used to provide redundant coverage or extend coverage in large areas (panel dependent)
- Unlimited wireless zones
- Spatial Diversity System virtually eliminates "nulls" and "dead spots" within the coverage area
- Connects to control panel via the keypad bus
- UL Listed for commercial fire/burglary applications

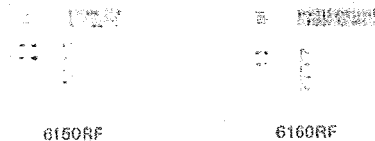

ALSO AVAILABLE: (In Keypad section)

**6150RF** – Deluxe Fixed English Integrated Keypad/Receiver

**6160RF** – Deluxe Custom Alpha Integrated Keypad/Receiver

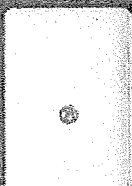

**5800ZBRIDGE**  
The Z-Bridge controls Z-Wave® enabled thermostats and lights automatically when it receives the armed "away" or "disarm" signal from a LYNX or VISTA® (with RF keypad) control panel.

#### 5800ZBRIDGE

- Wireless set back control of Z-Wave enabled thermostats
- Wireless on/off control of Z-Wave lighting devices
- Supports up to
  - Two individual Z-Wave enabled thermostats
  - Two individual Z-Wave lighting devices
- Sends thermostat set-back/lights off when security system is armed "away"
- Sends thermostat run /lights on when security system is "disarmed"
- LED indicator of system armed "away" or "stay" and "ready to arm"
- Compatible with all LYNX controls and VISTA Plus (with RF keypad) controls
- Power: 12VDC transformer included
- Dimensions: 4-1/2 H" x 2- 3/4 W" x 1/4 D"

## 5800 Wireless Series

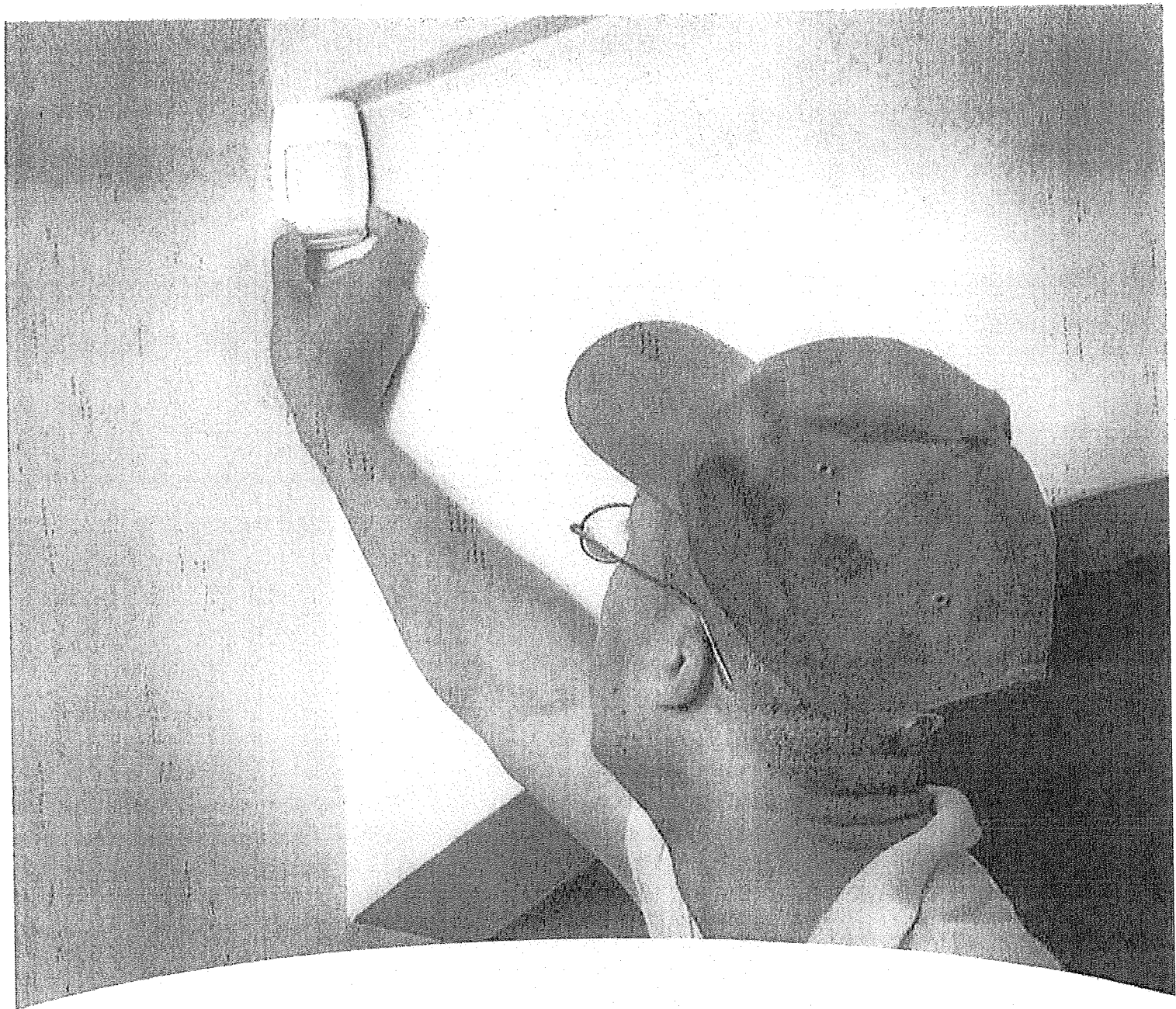

ADVANCED, QUICK-INSTALL SOLUTIONS FOR  
TODAY'S CONNECTED HOME AND BUSINESS

## The Wireless Advantage

**Honeywell**



## Wireless Solutions for Today's Connected Home and Business

You know Honeywell's 5800 Series as the most flexible, convenient and cost-effective wireless security in the industry, with over 100 million devices installed trouble-free. They make even the most labor-intensive jobs quicker, easier and more profitable.

Today, we've evolved - with a dynamic line of products that combine security and lifestyle benefits for the connected consumer. These solutions are designed to help you earn RMR quicker and move on to the next installation faster -- including products that enhance life safety, protect outdoor valuables, prevent theft and enhance end-user awareness.

They're the best way to connect to opportunity.

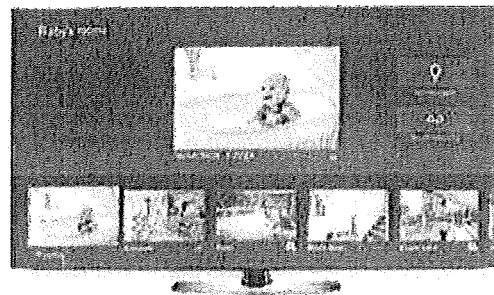

## Connect to Opportunity

An excellent complement to 5800 Series wireless technology, Honeywell Total Connect<sup>®</sup> Remote Services ties all the devices in consumers' homes and businesses together on one platform—keeping them connected and in control with a single app anytime, anywhere on their everyday smart devices. The lifestyle-enhancing service lets your customers:

- Control security, lights, thermostats and locks remotely on their iPhone<sup>®</sup>, iPad<sup>®</sup> or Android<sup>™</sup> devices
- Know exactly when their children get home from school, when pet sitters or caregivers arrive, when employees come and go and more
- Get iOS push notifications, texts, emails and video alerts when important events occur
- Remotely view live video on up to six cameras at a time
- Keep tabs on teenage and elderly drivers, employees, cars, fleets and valuables with GPS tracking
- Elevate their connected home experience with the SkyBell<sup>™</sup> Video Doorbell, August Smart Lock<sup>™</sup> and Total Connect Comfort Wi-Fi<sup>™</sup> and RedLINK<sup>™</sup> Connected Thermostats—all part of our dynamic, growing ecosystem
- Conveniently view live, streaming video, view multiple locations, record video clips and see live security system status on their televisions via the Apple TV<sup>™</sup> App
- Control security, keep tabs on multiple locations and activate Z-Wave<sup>™</sup> Smart Scenes with the Apple Watch<sup>™</sup> App

© 2015 Honeywell International Inc.  
 All rights reserved. Honeywell is a registered trademark.

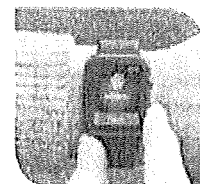



# Wireless Transmitters/Keys

15% smaller  
than previous  
version

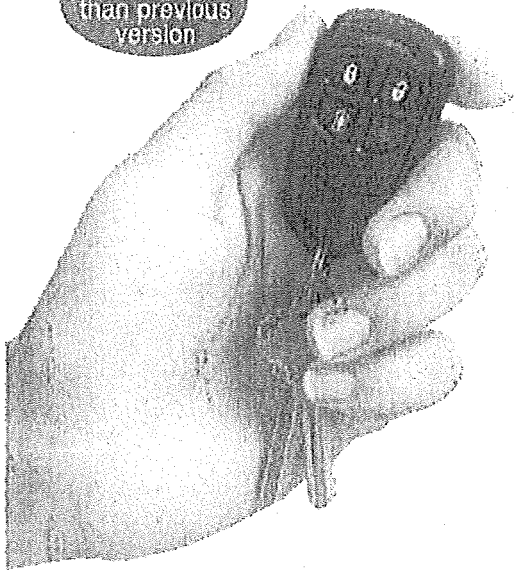

## 5834-4 Wireless Key

Security, Convenience and Style at Your Customers' Fingertips

Stand out to your customers with the 5834-4 Four-button Wireless Key.

Exciting features like the sleek, compact size, LED, eight programmable functions and more provide you with a great way to increase your sales.

- Compact size and comfortable, tactile keys
- Four programmable keys with up to eight functions let end-users summon police, fire and other emergency response personnel with the press of a button
- Tactile keys are recessed to help prevent false alarms
- Supports both Standard and High-Security (Encrypted) modes

## 5800MINI Door/Window Contact

Featuring an LED status indicator and a sleek, compact design, the 5800MINI virtually disappears when installed and blends with any décor—making it ideal for applications where aesthetics are critical such

as ornate doors, casement and double-hung windows. It provides a single zone of protection and installs easily on doors or windows with the included double-sided adhesive tape.

## 5800RPS Recessed Transmitter

The world's smallest wireless recessed transmitter, Honeywell's 5800RPS

disappears when installed on doors and windows, making it ideal for any installations where aesthetics matter.

## 5800MICRA Mini Window Recessed Transmitter

Honeywell's 5800MICRA is compact and ideal for vinyl windows.

It also provides

clean, fast installations, up to a ten year battery life and exceptional range. You'll want to use it on every job where aesthetics and discretion are important.

## 5818MNL Recessed Transmitter

With its small, sleek, tapered design, the 5818MNL is another great example of how our technology

has evolved to meet your needs. The low-profile design makes it perfect for discreet applications.

## 5815/5815WG Door/Window Transmitters

Ideal for installations when discretion and appearance are critical, these versatile transmitters are available in both standard models and a version with an extra 1" + gap. They provide

convenient, cost-effective door and window protection, and feature dual reed switches for added reliability.

## 5820L Slimline Transmitter

At nearly one third smaller than standard transmitters, Honeywell's 5820L is an ideal choice for casement and double-hung windows.

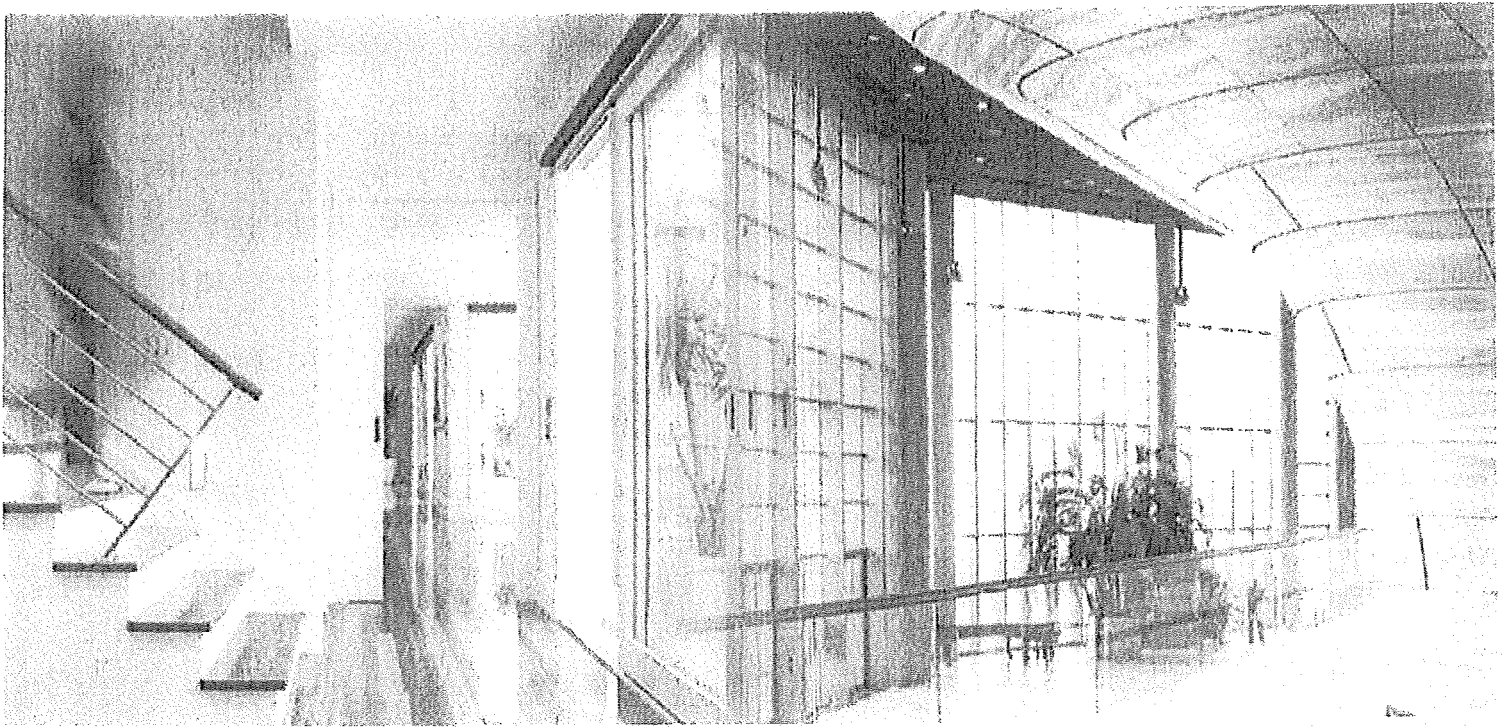

## Motion Detectors

### 5800PIR Motion Detectors

The 5800PIR Series pack some big benefits into a sleek, compact design—including easy, flexible programming, fewer service calls, reduced false alarms and more. Features include compatibility with Honeywell Total Connect® Remote Services for alerts when temperatures fall below 45°F, an automatic walk test, the ability to turn on the walk test mode with a flashlight, housings that can be custom-painted to match any décor, remotely programmable pet immunity (between 80 lbs. or 0 lbs.), the ability to operate in temperatures as low as -4°F/-20°C, longer range patterns for commercial installations and much more.\*

### 5898 K-Band DUAL TEC®

The 5898 Wireless K-Band DUAL TEC Motion Sensor provides superior detection while reducing the risk of false alarms. The combination of microwave and PIR technologies enable the sensors to distinguish between real intruders and environmental conditions by confirming each other within a defined area of protection. Additional features include a sleek, compact design, easy installation thanks to an automatic walk test and flashlight walk test, a cold temperature alert option with Honeywell Total Connect Remote Services compatibility and much more.

\*Availability of features depends upon the version of PIR selected. Models include the 5800PIR-RES and the 5800PIR-COM. Consult data sheets for details.



# Life Safety

**NEW!**

## 5800COMBO Smoke/Carbon Monoxide Detector

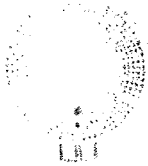

The 5800COMBO is a professionally installed and monitored, multi-criteria smoke and carbon monoxide detector for homes. It contains a built-in transmitter that enables central-station alarm monitoring of dangerous smoke and CO gas, as well as maintenance supervision. The 5800COMBO also includes voice annunciation, visual alerts and temperature reporting clusters.

- Reacts faster to real danger and reduces false alarms
- Reduces the need to sell and install two separate detectors—saving both you and your customers money
- Crystal clear, multi-lingual voice annunciation and feedback helps occupant clearly distinguish between alarms and other maintenance sounds
- User-replaceable batteries save time and maximize efficiency
- Clear visual notification of alarm conditions with 360° viewable side LEDs
  - Red: Smoke
  - Blue: CO



Smarter, Intuitive, Reliable Detection—  
New Two-in-One Device



## 5808W3 Photoelectric Smoke/Heat Detector

Honeywell's 5808W3 Photoelectric Smoke/Heat Detector with a built-in wireless transmitter has been enhanced with exciting features to help reduce false alarms and increase profits, including:

- Smoothing algorithms that smooth out short-term spikes from dust and smoke
  - The ability to eliminate emergency service calls with Smart Check, which sends a signal to the control panel when the detector requires cleaning—allowing a regular, non-emergency service call to clean the detector before it goes into alarm
  - Low temperature alerts
  - One 3V lithium battery for longer battery life and easier maintenance
  - Improved RF signal for larger commercial installations and increased overall sales
  - Additional green LED status indicator for added security and monitoring convenience
  - Reduced testing time, thanks to the handheld SENS-RDR Infrared Sensitivity Reader, which eliminates the need for magnets, voltmeters and ladders
- Also available: 5806W3 Wireless Smoke Detector and 5809 Wireless Heat Detector.*

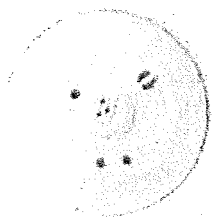

## 5800CO Carbon Monoxide Detector

Carbon monoxide (CO) is an odorless, colorless, toxic gas that can kill in minutes. With Honeywell's 5800CO Wireless Carbon Monoxide Detector, you can provide your customers with the very best defense against this deadly threat. It connects to the end-user's security system and can be monitored 24 hours a day, seven days a week. The detector features state-of-the-art sensing technology to help prevent false alarms and a wireless design that makes installation a snap. What's more, it's an excellent upsell opportunity and a great way to differentiate yourself by adding value and life safety to your installations.

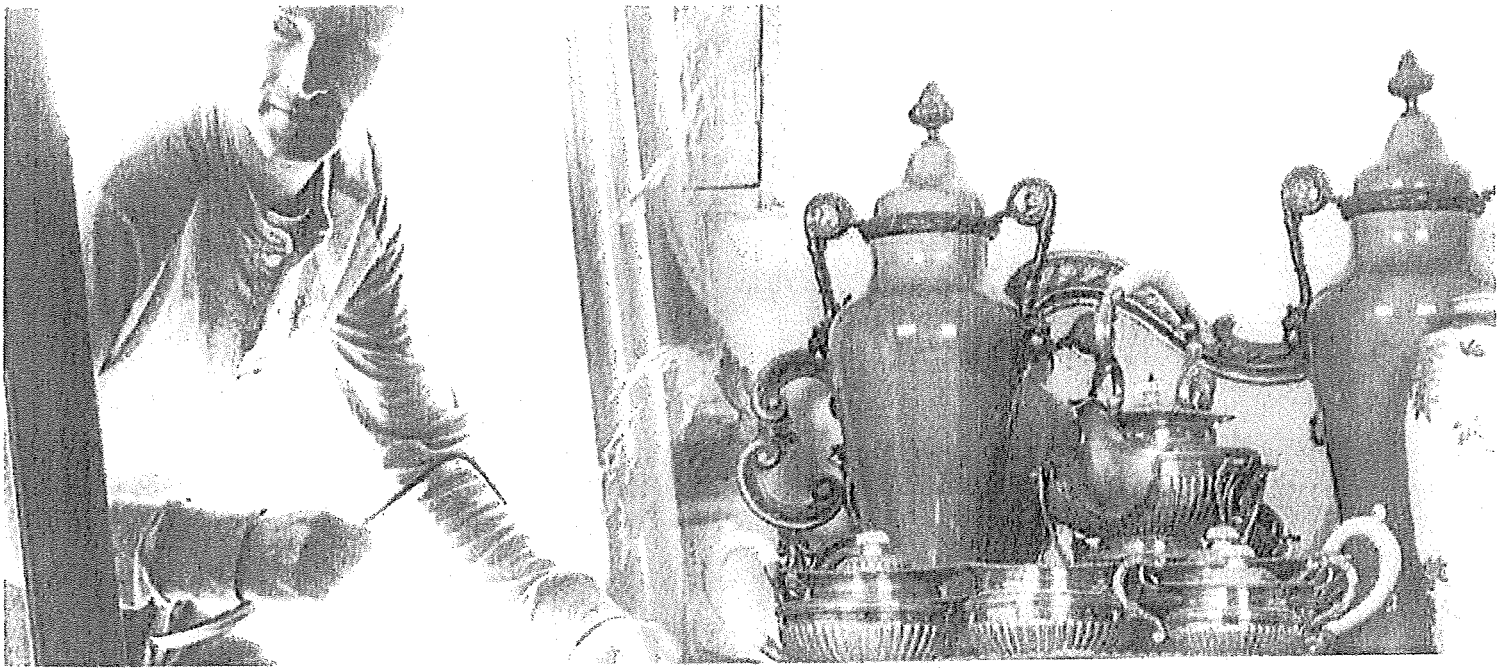

## Glassbreaks and Environmental Detection

### 5853 Glassbreak Detector

Honeywell's 5853 offers a wireless FlexGuard® solution to protect all types of glass. Installers rely on FlexGuard as a first line of defense, because it keeps intruders where they belong...outside. You'll provide your customers with the highest level of security possible—without any labor and installation headaches or costly service calls.

### 5800SS1 Shock Sensor

This compact, versatile detector mounts directly on the glass surface and offers excellent protection for all glass types—including plate, tempered, laminated and wired. It provides outstanding false alarm immunity, especially in problem areas such as kitchens and bathrooms. It's ideal for hard to reach areas like skylights.

### 5819S Door/Window Shock Sensor Combo

The 5819S combination magnetic contact and shock sensor provides two types of protection in one product—open and closed conditions of doors and windows, and with built-in shock sensing technology, it can detect abrupt, forcible attempts at entry. Four simple settings make setup a snap and an omnidirectional shock sensor provides maximum versatility when mounting around door and window frames.

### 5821 Temperature/Flood Sensor

Honeywell's 5821 is a versatile wireless device that can be configured to operate as either a standalone temperature sensor and/or a remote temperature sensor or flood detector. It is ideally suited for a wide range of applications including bathrooms, laundry rooms and basements.

## Theft Prevention

### 5870API Indoor Asset Sensor



Until now, many dealers have had to walk away from protecting assets within a home or

business—even when asked—due to the high costs, complexity and labor involved.

Honeywell's 5870API changes all of that. The device easily affixes to virtually any valuable requiring protection within a home or business, including paintings, flat screen TVs and other electronics, family heirlooms, safes, office equipment and more. It lets you offer an additional layer of protection that can be programmed to always be on—even when the panel is disarmed.

The 5870API is an excellent way to provide your customers with a unique solution to a problem most dealers overlook...theft. Remember, theft is different from burglary because it occurs without a break-in and the offender has a legal right to be on the premises. With the 5870API, you'll actually protect against burglary and theft at the same time.

# Wireless Outdoor Protection

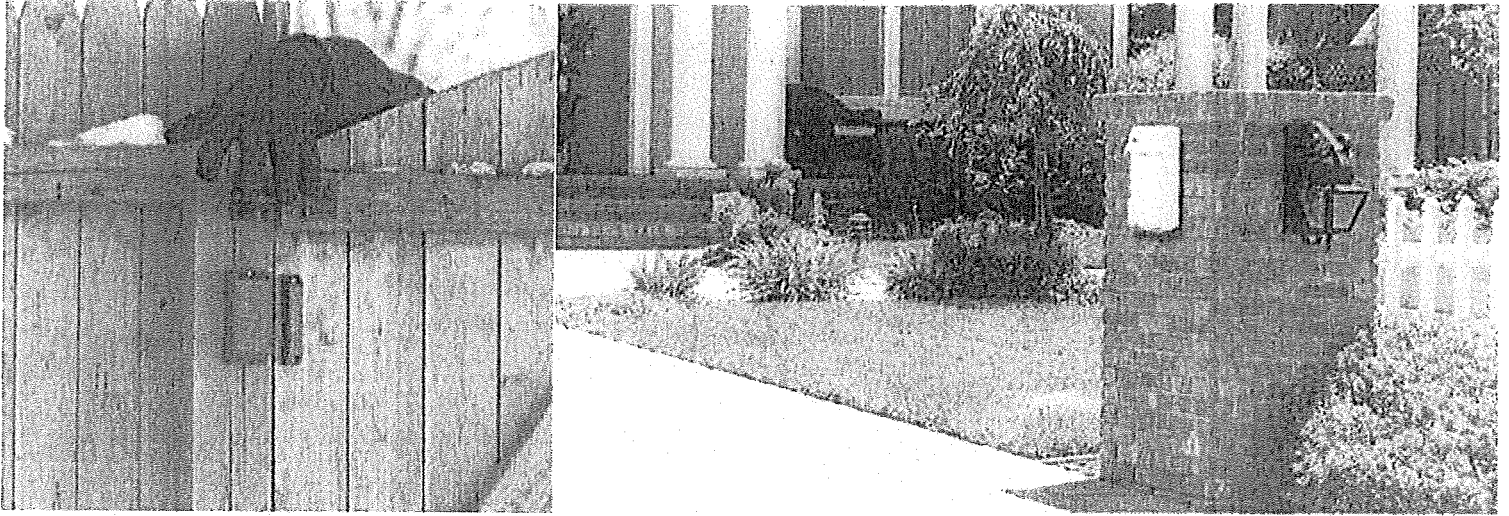

An integral part of our connected home and building solutions, Honeywell's robust, all-weather wireless outdoor contacts and sensors keep your customers aware of what's going on around the exterior of their homes and businesses while creating a safer environment.

## 5800PIR-OD Wireless Outdoor Motion Sensor



- Provides superior protection for pool areas, rooftops, exits, entrances, car lifts, cellular sites and more
- Easy installation—no trenching, excavating or subcontracting
- Weather-proof (IP54 rated) and water-resistant housing with a temperature range of -4°F to 122°F
- Range adjustable up to 40 feet with a 90° adjustable pattern
- Provides false alarm immunity to pets, small animals and other outdoor disturbances
- Dual passive infrared design—both PIRs must be tripped to declare an alarm
- Compatible with Honeywell Total Connect® Remote Services, VISTA® and LYNX controls

## 5816OD Outdoor Wireless Contact

- Ideal for gates, fences, barns, sheds, outdoor equipment and valuables
- Easy installation with a wide gap of 1.75" (1.25" on steel)
- Operates in temperatures from -40°F to 150°F (-40°C to +66°C), (100% RH)
- Weather-proof (NEMA 4X rated) and water-resistant housing
- Can be custom-painted to match mounting surface
- Long-life AA lithium batteries that your customers can change themselves
- Compatible with Honeywell Total Connect Remote Services, VISTA and LYNX controls

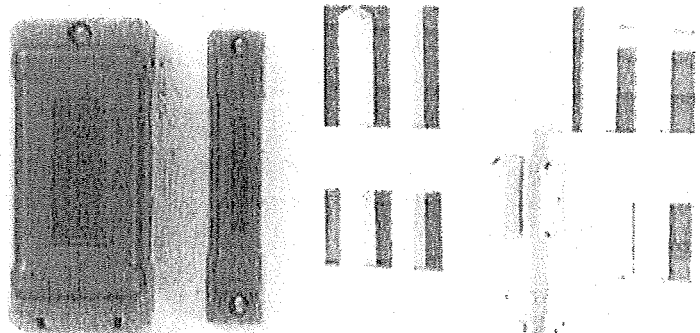

*iPhone, iPad, Apple TV and Apple Watch are registered trademarks of Apple Inc.*

*All other trademarks are property of their respective owners.*

**For more information:**

[www.honeywell.com/security](http://www.honeywell.com/security)

**Honeywell Security and Fire**

2 Corporate Center Dr. Suite 100

P.O. Box 9040

Melville, NY 11747

1.800.323.4576

[www.honeywell.com](http://www.honeywell.com)

**Honeywell**

L/EV016R/D  
March 2017  
© 2017 Honeywell International Inc.

# Honeywell's Traditional Keypad Family

## Landscape Keypads

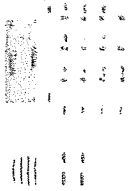

6150RF  
Fixed-English

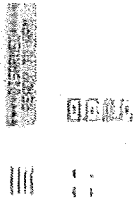

6160  
Custom Alpha

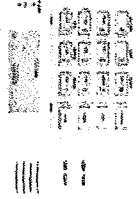

6150V  
Fixed-English

## Voice Keypads with Message Center

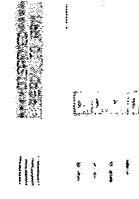

6160V  
Custom Alpha

## Keypads with Integrated Wireless Receiver (Zone Expansion)

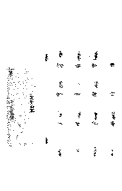

6150RF  
Fixed-English with 16 Wireless Zones and One Relay

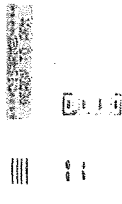

6160RF  
Custom Alpha (with as many zones as panel supports)

## Keypad with Integrated Hardwired Expander (Zone Expansion)

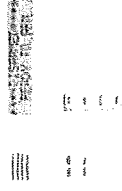

6164US  
Custom Alpha with Four Hardwired Zones and One Relay

## Wireless Keypads



5828  
Fixed-English



5828V  
Fixed-English with Voice Announcement and Message Center

Also available: 5828 Desk Mount and Transformer

# Honeywell's Premium Keypad Family

## Premium Design Keypads

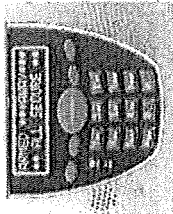

6460S  
Custom Alpha in  
Silver and Black

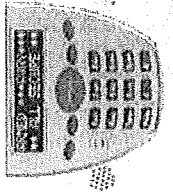

6460W  
Custom Alpha in  
White and Gray

## Slimline Keypads (Portrait Style)

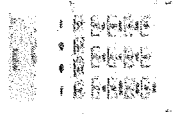

6149EX  
Fixed-English



6165EX  
Custom Alpha

## Fire Keypad – Commercial

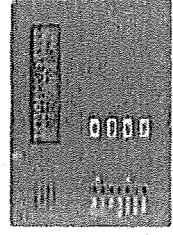

6160CR-2  
Custom Alpha UL864 Listing

## Graphic Keypads – High Resolution Display with Built-in Digital Picture Frame and/or Billboard

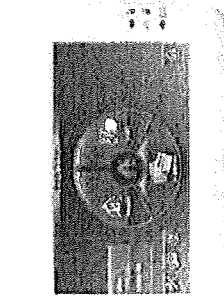

6280W  
White

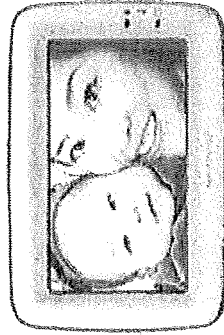

6280S  
Silver



TUXWIFIW  
White

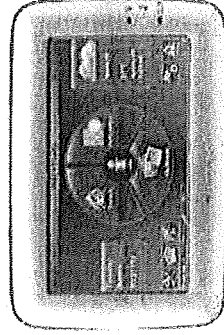

TUXWIFIS  
Silver

## Color Graphic Voice Touchscreen Security Keypad and Home/Business Controller with Integrated Wi-Fi®

# 4 MP Fixed Wedge Network Camera

## 4 MP IR Wedge Network Camera



- 1/3-in. 4 MP Progressive Scan CMOS
- Triple-stream Encoding
- Smart H.265+ Video Compression
- 4 MP (2688 x 1520) at 30 fps Maximum Resolution
- Smart Detection Support
- True Wide Dynamic Range (120 dB) and True Day/Night
- Built-in Microphone
- 2.8 mm or 3.6 mm Fixed Lens Options
- Maximum IR LED Length 20 m (65 ft)
- Micro SD Memory, IP67, IK10, PoE
- Five-year Warranty\*



### System Overview

Dahua's Mobile series of cameras offers high-resolution video and cutting-edge technology in a compact and accessible package. The cameras feature H.265 video compression, reducing bandwidth and storage requirements without sacrificing video quality. The camera series incorporates True Wide Dynamic Range, Smart IR, and the Intelligent Video Analysis, features typically found on high-end surveillance systems. This series provides a rugged enclosure rated to IP67 Ingress Protection to protect your security investment.

### Functions

#### Wide Dynamic Range

For applications with both bright and low-light conditions that change quickly, True WDR (120 dB) optimizes both the bright and dark areas of a scene at the same time to provide usable video.

#### Intelligent Video System (IVS)

IVS is a built-in video analytic algorithm that delivers intelligent functions to monitor a scene for tripwire violations, intrusion detection, and abandoned or missing objects. A camera with IVS quickly and accurately responds to monitoring events in a specific area. In addition to scene analytics, the camera offers tamper detection by recognizing a dramatic scene change and generating a warning message to inspect the camera.

#### High Efficiency Video Coding (H.265)

The H.265 (ITU-T VCEG) video compression standard offers double the data compression ratio at the same level of video quality, or substantially improved video quality at the same bit rate, as compared to older video compression technologies. H.265 offers such impressive compression by expanding the pattern comparison and difference-coding, improving motion vector prediction and motion region merging, and incorporating an additional filtering step called sample-adaptive offset filtering.

#### Smart H.265+

Smart H.265+ is the optimized implementation of the H.265 codec that uses a scene-adaptive encoding strategy, dynamic GOP, dynamic ROI, flexible multi-frame reference structure and intelligent noise reduction to deliver high-quality video without straining the network. Smart H.265+ technology reduces bit rate and storage requirements by up to 70% when compared to standard H.265 video compression.

#### Smart IR

With IR illumination, detailed images can be captured in low light or total darkness. The camera's Smart IR technology adjusts the intensity of the camera's infrared LEDs to compensate for the distance of an object. Smart IR technology prevents IR LEDs from whitening out images as they come closer to the camera.

#### Environmental

With a temperature range of 30 °C to +60 °C ( 22 °F to +140 °F), the camera is designed for extreme temperature environments. The camera complies with an IK10 impact rating making it capable of withstanding the equivalent of 5 kg (11.02 lbs) of force dropped from a height of 40 cm (15.75 in.). Subjected and certified to rigorous dust and water immersion tests, the IP67 rating makes it suitable for demanding outdoor applications.

#### Protection

Supporting ±30% input voltage tolerance, this camera suits even the most unstable conditions for outdoor applications. Its 6kV lightning rating provides protection against the camera and its structure from the effects of lightning.

**Technical Specification**

**Camera**

Image Sensor	1/3-in. 4 MP Progressive Scan CMOS
Effective Pixels	2688(H) x 1520(V)
RAM/ROM	512 MB / 32 MB
Scanning System	Progressive
Minimum Illumination	Color: 0.08 Lux at F2.0 0 Lux at F2.0 with IR on
S/N Ratio	More than 50 dB
IR Distance	Distance up to 20.0 m (65.60 ft)
IR On/Off Control	Auto, Manual
IR LEDs	10

**Lens**

Lens Type	Fixed
Mount Type	Board-In
Focal Length	N44BN52: 3.5 mm N44BN53: 3.6 mm
Maximum Aperture	F2.0

Angle of View	Horizontal	N44BN52: 104° N44BN53: 87°
	Vertical	N44BN52: 57° N44BN53: 48°

Focus Control	Fixed
---------------	-------

**Pan/Tilt/Rotation**

Range	Pan: 0° to 360° Tilt: 0° to 80° Rotation: 0° to 360°
-------	--

**Video**

Compression	Smart H.265+, H.265, Smart H.264+, H.264, MJPEG
-------------	---

Streaming Capability	Three (3) Streams
----------------------	-------------------

Resolution	4 MP (2688 x 1520)
	3 MP (2304 x 1296)
	1080p (1920 x 1080)
	1.3 MP (1280 x 960)
	720p (1280 x 720)
	D1 (704 x 480)
	VGA (640 x 480)
CIF (352 x 240)	

	Main Stream: 4 MP at 30 fps
--	-----------------------------

Frame Rate	Sub Stream: D1 at 30 fps
------------	--------------------------

	Third Stream: 720p at 30 fps
--	------------------------------

Bit Rate Control	CBR, VBR
------------------	----------

Bit Rate	H.264: 24 to 10240 Kbps H.265: 14 to 6144 Kbps
----------	---

Day/Night	Auto (ICR), Color, B/W
-----------	------------------------

BLC Mode	BLC, HLC, True WDR (120 dB)
----------	-----------------------------

White Balance	Auto, Natural, Street Lamp, Outdoor, Manual
---------------	---

Gain Control	Auto, Manual
--------------	--------------

Noise Reduction	3D DNR
-----------------	--------

Motion Detection	Off, On (4 Zone, Rectangle)
------------------	-----------------------------

Region of Interest	Off, On (4 Zone)
--------------------	------------------

Smart IR	Support
----------	---------

Digital Zoom	16x
--------------	-----

Flip	0°, 90°, 180°, 270°
------	---------------------

Privacy Masking	Off, On (4 Area, Rectangle)
-----------------	-----------------------------

**Audio**

Compression	G.711a, G.711Mu, AAC, G.726
-------------	-----------------------------

**Network**

Ethernet	RJ-45 (10/100 Base-T)
----------	-----------------------

Protocol	HTTP, HTTPS, TCP, ARP, RTSP, RTP, UDP, SMTP, FTP, DHCP, DNS, DDNS, PPPOE, IPv4/v6, QoS, UPnP, NTP, Bonjour, 802.1x, Multicast, ICMP, IGMP, SNMP
----------	---

Interoperability	ONVIF, PSIA, CGI
------------------	------------------

Streaming Method	Unicast, Multicast
------------------	--------------------

Max. User Access	10 Users / 20 Users
------------------	---------------------

Edge Storage	NAS Local PC for Instant Recording MicroSD Card, maximum 128 GB
--------------	---

Web Viewer	IE, Firefox, Safari
------------	---------------------

Management Software	Smart PSS, DSS
---------------------	----------------

Mobile Operating System	iOS, Android
-------------------------	--------------

**Certifications**

Safety	UL60950-1
--------	-----------

Electromagnetic Compatibility	FCC Part 15 Subpart B
-------------------------------	-----------------------

**Interface**

Audio	Built-in Microphone
-------	---------------------

**Electrical**

Power Supply	12 VDC, PoE (802.3af, Class 0)
--------------	--------------------------------

Power Consumption	< 4.5 W
-------------------	---------



**Environmental**

Operating Conditions	-30° C to +60° C (-22° F to +140° F), Less than 95% RH
Storage Conditions	-30° C to +60° C (-22° F to +140° F), Less than 95% RH
Ingress Protection	IP67
Vandal Resistance	IK10

**Construction**

Casing	Metal
Dimensions	ø106.0 mm x 50.30 mm (ø4.17 in. x 1.98 in.)
Net Weight	0.40 kg (0.88 lb)
Gross Weight	0.44 kg (0.97 lb)

**Intelligence**

IVS triggers an alarm and takes a defined action for the following events:

- Standard Features
- Tampering with the camera.
  - Error writing to an onboard Micro SD card.
  - Error sending or receiving data over the network.
  - Unauthorized access to the camera.

**Premium Features**

Motion	An object moves through any part of the scene.
Tripwire	A target crosses a user-defined line.
Intrusion	A target enters or exits a defined perimeter.
Scene Change	A person or object moves the camera to change the scene or covers the camera to obscure the scene.
Abandoned/Missing Object	A target leaves an object in designated area, or a target removes an object from the same designated area.

**Accessories**

**Optional:**



PFA139  
Junction Box



PFB204W  
Wall Mount



PFA152  
Pole Mount

Junction Mount	Pole Mount
PFA139	PFB204W + PFA152
Wall Mount	
PFB204W	

**Ordering Information**

Type	Part Number	Description
4 MP camera	N44BN52	4 MP IR Mini Dome Network Camera, 2.8 mm, WDR, IVS
	N44BN53	4 MP IR Mini Dome Network Camera, 3.6 mm, WDR, IVS
Accessories (optional)	PFB204W	Wall mount
	PFA139	Junction box
	PFA150	Pole mount
	PFA152	Pole mount

**Dimensions (mm/inch)**

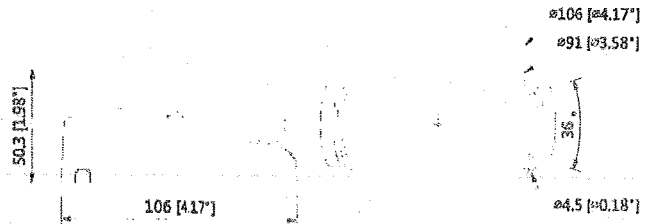

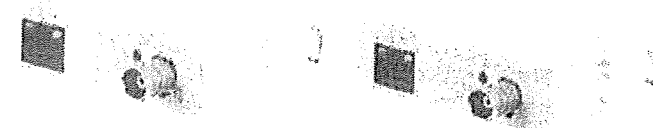

## INVID-IPOVERCOAX

IP Over Coax Passive Converters.  
(Includes INVID-IPOVERCOAX-RX & INVID-IPOVERCOAX-TX)

### Features

- Ethernet & Power transmission over Coaxial cable
- No power adapter is required
- Up to 2,000ft
- Compact design (79mm×52mm×23mm)
- Interface: 1×RJ45 10/100Mbps, 1×BNC RG59 coaxial
- Supports MDI/MDIX self-adaption

Model	INVID-IPOVERCOAX-TX INVID-IPOVERCOAX-RX
Function Port	1×10/100 Mbps Base-TX 1×BNC
Power Consumption	<2W
Transmission Bandwidth	RG59 coaxial cable: 400m/100Mbps. 1000m/10Mbps
PoE Protocol	IEEE802.3af, IEEE802.3at
Network Standard	IEEE802.3, IEEE802.3u, IEEE802.3x
Lightning Protection	Common Mode 4KV Differential Mode 2KV
Operating Temperature	-22° ~ 149° F (-30° ~ 65° C)
Operating Humidity	5-95%
Weight	0.13 lbs (61g)
Dimensions (WxDxH)	3.11 x 2.04 x .9" (79 x 52 x 23mm)

### Application

- Perfect to upgrade analog system to IP surveillance system
- PoE Video & Power extension up to 2000 Feet
- Works with all InVid Tech and other PoE IP Cameras

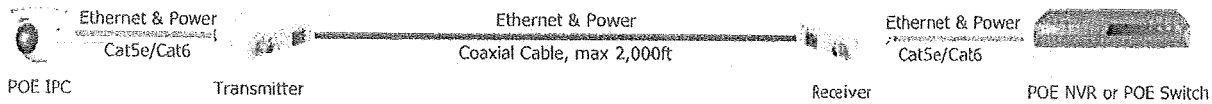

### PoE Power Supply Specifications (RG59 Coaxial Cable)

Cable Length (m)	Communication Bandwidth (Mbps)	PoE Max Load Capacity (W)	Network Operating Mode
100	100	21	E100
200	100	15	E100
300	100	11	F100
400	100	9	E100
500	10	7	E10
800	10	5	E10
1000	10	4	E10

ePoE switch power supply voltage is 48V.

RG-59 max. DC resistance <50/100m.

Caution: The load capacity can be applied to networking scheme 3. Cable length means the total wire length from switch to transmitter (including network cable and coaxial cable). It can be used max 2m network cable to connection transmitter to IPC.

Cable Length (m)	Communication Bandwidth (Mbps)	PoE Max Load Capacity (W)	Network Operating Mode
100	100	25.5	E100
200	100	24	E100
300	100	19	F100
400	100	16	F100
500	10	13	E10
800	10	8	E10
1000	10	6	F10

ePoE switch power supply voltage is 53V.

RG-59 max. DC resistance <50/100m.

Caution: The load capacity can be applied to networking scheme 3. Cable length means the total wire length from switch to transmitter (including network cable and coaxial cable). It can be used max 2m network cable to connection transmitter to IPC.

### Ordering Information

INVID-IPOVERCOAX: IP Over Coax Passive Converters

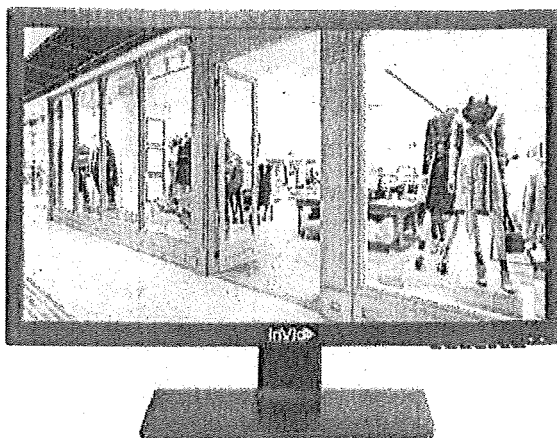

## IMHD-22HVB

21.5" Full HD 1920 x 1080 LED Monitor  
HDMI, VGA, Looping BNC Inputs & Outputs

### Features

- Suitable for All Video Surveillance and Security applications
- Full High Definition Quality: 1920 x 1080
- Bright LED Illuminated Panel with 170° Viewing Angle
- Inputs: HDMI, VGA, BNC
- Outputs: BNC
- 16.7 Million Color Capacity
- VESA Mount Compatible

<b>Display</b>	
Screen Size	21.5" 1FH
Backlight Type	LED
Aspect Ratio	16:9
Brightness	220 cd/m <sup>2</sup>
Contrast Ratio	1000:1 Static CR
Resolution	1920 x 1080
Response Time	5ms (G2G)
Viewing Angle	170°/150° (CV>10)
Color Support	16.7M
Pixel Pitch	0.2482 (h) x 0.2482 (v) mm
Active Display Area	476.64 (h) x 268.11 (v)
Frequency	30-80KHz (h) / 50-75Hz (v)
<b>Input</b>	
Connector	BNC-In x 1, BNC-Out x1, VGA-In x 1, HDMI-In x 1
<b>Features</b>	
Plug & Play	Supported
Color Temperature Options	Warm, Medium, Cool, User
VESA Mount	100 x 100mm
Remote Control	Yes
Accessory	Remote Control, Signal Cable, User Manual, Power Adapter
Cabinet Color	Black Plastic
<b>Weight &amp; Power</b>	
Net Weight	8.59 lbs (3.9 kg)
Gross Weight	10.58 lbs (4.8 kg)
Operating Humidity	20-70% RH
Power Consumption	Typical 20W
Stand By Power	<0.5W
Type	DC12V 2A

### Ordering Information

IMHD-22HVB: 21.5" HDMI Monitor

InVID Tech reserves the right to make changes to improve our products at any time without notice, we are not responsible for misprints.

# 4MP IR Vari-focal ePoE Bullet

WDR IR Bullet Network Camera

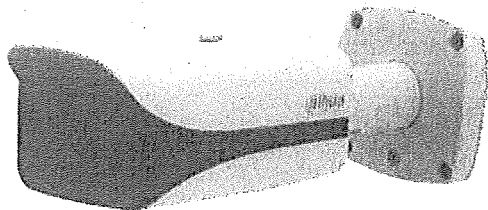

- 1/3-in. 4 MP Progressive-scan CMOS Sensor
- Triple-stream Encoding
- Smart H. 265+ and H.264 Dual Codec
- 4 MP at 30 fps Maximum Resolution
- 2.7 mm to 13.5 mm Motorized Optical Zoom Lens
- Enhanced Power and Data Transmission Distances (ePoE)
- True Wide Dynamic Range (120 dB) and True Day/Night (ICR)
- Maximum IR LED Distance 50 m (164 ft)
- IP67 Ingress Protection and IK10 Vandal Resistance
- Intelligent Video System
- Five-year Warranty\*



## System Overview

The 4 MP bullet camera features an advanced 1/3-in. Progressive-scan imager with a 2.7 mm to 13.5 mm vari-focal lens. The camera offers True Wide Dynamic Range, a True Day/Night IR Cut filter, IP67 Ingress Protection and operation in extreme temperatures to deliver superior images in all lighting and environmental conditions. The camera is a component of Dahua's innovative Enhanced Power over Ethernet (ePoE) system that transmits power and data over long distances without the need for repeaters or multiple switches.

## Functions

### Enhanced Power over Ethernet (ePoE) Technology

Dahua's innovative ePoE technology offers a plug-and-play solution to transmit power and data over long distances via Ethernet or coaxial cables, reducing installation time and saving money. ePoE technology is a viable, cost-effective solution for extending transmission distances and for converting existing, coax-based analog systems into IP systems. For video security and surveillance installers, ePoE technology saves time and money by reducing overall cabling requirements, allowing for existing coax cable to be used, and minimizing the number of peripheral devices needed. For new installations, ePoE offers the ability to design long-distance applications without the need for additional repeaters.

Enhanced PoE encompasses pure IP systems where a single CAT 5 cable can carry signals up to 800 m (2624 ft), and IP/Analog hybrid systems where the technology leverages existing analog infrastructure to transmit power and data up to 1000 m (3281 ft) over RG59 coaxial cable. Enhanced PoE is compatible with three connection modes operating over the same network simultaneously: traditional IP networks, long-distance ePoE networks and coaxial networks. ePoE technology seamlessly integrates the latest high-definition IP cameras with a coaxial infrastructure using the Ethernet over Coaxial (EoC) protocol to convert between analog and IP power and data transmissions.

### True Wide Dynamic Range (WDR)

The camera achieves vivid images, even in the most intense contrast lighting conditions, using industry-leading wide dynamic range (WDR) technology. For applications with both bright and low lighting conditions that change quickly, True WDR (120 dB) optimizes both the bright and dark areas of a scene at the same time to provide usable video.

### Intelligent Video System (IVS)

IVS is a built-in video analytic algorithm that delivers intelligent functions to monitor a scene for Tripwire violations, intrusion detection, and abandoned or missing objects. A camera with IVS quickly and accurately responds to monitoring events in a specific area. In addition to scene analytics, the camera supports face detection to quickly capture a face and upload the image to a server. The camera also offers tamper detection by recognizing a dramatic scene change and generating a warning message to inspect the camera.

### Smart H.265+

Smart H.265+ is the optimized implementation of the H.265 codec that uses a scene-adaptive encoding strategy, dynamic GOP, dynamic ROI, flexible multi-frame reference structure and intelligent noise reduction to deliver high-quality video without straining the network. Smart H.265+ technology reduces bit rate and storage requirements by up to 70% when compared to standard H.265 video compression.

### Environmental

Dahua cameras operate in extreme temperature environments, rated for use in temperatures from -30° C to +60° C (-22° F to +140° F) with 95% humidity. The camera complies with the IK10 impact rating and is certified to rigorous dust and immersion tests (IP67), making the camera the choice for installation in even the most unforgiving environments.

**Technical Specification**

**Camera**

Image Sensor	1/3-in. 4 MP Progressive-scan CMOS				
Effective Pixels	2688(H) x 1520(V)				
RAM/ROM	512 MB/32 MB				
Scanning System	Progressive				
Electronic Shutter Speed	Auto, Manual, 1/3 s to 1/100,000 s				
Minimum Illumination	Color: 0.03 lux at F1.4 (1/3 s, 30 IRE) Color: 0.3 lux at F1.4 (1/30 s, 30 IRE) 0 lux at F1.4 (IR on)				
S/N Ratio	More than 50 dB				
IR Distance	Distance up to 50 m (164.04 ft)				
IR On/Off Control	Auto, Manual				
IR LEDs	Four (4)				
<b>Lens</b>					
Lens Type	Motorized, Auto Iris (DC)				
Mount Type	Board-In				
Focal Length	2.7 mm to 13.5 mm				
Maximum Aperture	F1.4				
Angle of View	Horizontal: 106° to 31° Vertical: 58° to 17°				
Optical Zoom	5x				
Focus Control	Motorized				
Close Focus Distance	0.30 m (0.98 ft)				
	Lens	Detect	Observe	Recognize	Identify
DORI <sup>1</sup> Distance	Wide	64 m (210 ft)	26 m (85 ft)	13 m (42 ft)	6.5 m (21 ft)
	Tele	208 m (682 ft)	83 m (272 ft)	41 m (136 ft)	20 m (68 ft)
<b>Pan/Tilt/Rotation</b>					
Range	Pan: 0° to 360° Tilt: 0° to 90° Rotation: 0° to 360°				
<b>Video</b>					
Compression	Smart H.265+, H.265, Smart H.264+, H.264				
Streaming Capability	Three (3) Streams				
Resolution	4 MP (2688 x 1520), 3 MP (2304 x 1296), 1080p (1920 x 1080), 1.3 MP (1280 x 960), 720p (1280 x 720), D1 (704 x 480), VGA (640 x 480) CIF (352 x 240)				
Frame Rate	Main Stream: 4 MP at 30 fps Sub Stream 1: D1 at 30 fps Sub Stream 2: 720p at 30 fps				
Bit Rate Control	CBR/VBR				
Bit Rate	H.264: 24 to 10240 Kbps H.265: 14 to 9984 Kbps				
Day/Night	Auto (ICR), Color, B/W				
BLC Mode	BLC, HLC, True WDR (120 dB)				

White Balance	Auto, Natural, Street Lamp, Outdoor, Manual
Gain Control	Auto, Manual
Noise Reduction	3D DNR
Motion Detection	Off, On (4 Zones, Rectangular)
Region of Interest	Off, On (4 Zones)
Smart IR	Support
Digital Zoom	16x
Flip	0°, 90°, 180°, 270°
Mirror	Off, On
Privacy Masking	Off, On (4 Areas, Rectangular)
<b>Audio</b>	
Compression	G.711a, G.711Mu, AAC, G.726
<b>Network</b>	
Ethernet	RJ-45 (10/100 Base-T)
Protocol	HTTP, HTTPS, TCP, ARP, RTSP, RTP, UDP, SMTP, FTP, DHCP, DNS, DDNS, PPPoE, IPv4/v6, QoS, UPnP, NTP, Bonjour, 802.1x, Multicast, ICMP, IGMP, SNMP
Interoperability	ONVIF, PSIA, CGI
Streaming Method	Unicast / Multicast
Max. User Access	10 Users /20 Users
Edge Storage	Network Attached Storage (NAS) Local PC for Instant Recording Micro SD Slot, maximum 128 GB
Web Viewer	IE, Chrome, Firefox, Safari
Management Software	SmartPSS, DSS
Smart Phone	iOS, Android
<b>Certifications</b>	
Safety	UL60950-1
Electromagnetic Compatibility (EMC)	FCC CFR 47 FCC Part 15 Subpart B
<b>Interface</b>	
Video	One (1) Port, for installation adjustment only
Audio	Input: One (1) Channel, RCA Output: One (1) Channel, RCA
Alarm	Input: Two (2) Channels (5 mA, 5 VDC) Output: One (1) Channel (300 mA, 12 VDC)
<b>Electrical</b>	
Power Supply	12 VDC, 1.5 A or PoE (IEEE 802.3af, Class 0)
Power Consumption	< 12.95 W

1. The DORI distance is a measure of the general proximity for a specific classification to help pinpoint the right camera for your needs. The DORI distance is calculated based on sensor specifications and lab test results according to EN 62676-4, the standard that defines the criteria for the Detect, Observe, Recognize and Identify classifications

**Environmental**

Operating Temperature -30° C to +60° C (-22° F to +140° F)  
Less than 95% RH

Storage Temperature -30° C to +60° C (-22° F to +140° F)  
Less than 95% RH

Ingress Protection IP67

Vandal Resistance IK10

Lightning Protection 6 KV

**Construction**

Casing Metal

Dimensions 273.20 mm x 95.0 mm x 95.0 mm  
(10.76 in. x 3.74 in. x 3.74 in.)

Net Weight 1.11 kg (2.44 lb)

Gross Weight 1.51 kg (3.33 lb)

**Intelligence**

IVS triggers an alarm and takes a defined action for the following events:

**Standard Features**

- Tampering with the camera.
- Error writing to an onboard Micro SD card.
- Error sending or receiving data over the network.
- Unauthorized access to the camera.

**Premium Features**

- Motion** An object moves through any part of the scene.
- Tripwire** A target crosses a user-defined line.
- Intrusion** A target enters or exits a defined perimeter.
- Scene Change** A person or object moves the camera to change the scene or covers the camera to obscure the scene.
- Abandoned/Missing Object** A target leaves an object in designated area, or a target removes an object from the same designated area.

**ePoE Transmission Distances**

**Via CAT5E/CAT6 Ethernet Cable**

ePoE supply voltage 48 V  
Maximum DC resistance < 10 Ω/100 m

Cable Length, m (ft)	Bandwidth, Mbps	PoE Load Capacity, W	Hi-PoE Load Capacity, W	Working Mode
100 (328)	100	25.5	53	IEEE/E100
200 (656)	100	25.5	33	E100
300 (984)	100	19	19	E100
400 (1312)	10	17	17	E10
500 (1640)	10	13	13	E10
800 (2625)	10	7	7	E10

**Via CAT5E/CAT6 Ethernet Cable**

ePoE supply voltage 53 V  
Maximum DC resistance < 10 Ω/100 m

Cable Length, m (ft)	Bandwidth, Mbps	PoE Load Capacity, W	Hi-PoE Load Capacity, W	Working Mode
100 (328)	100	25.5	53	IEEE/E100
200 (656)	100	25.5	47	E100
300 (984)	100	25.5	32	E100
400 (1312)	10	23	26	E10
500 (1640)	10	20	20	E10
800 (2625)	10	13	13	E10

**Via RG-59 Coaxial Cable**

ePoE supply voltage 48 V  
Maximum DC resistance < 5 Ω/100 m

Cable Length, m (ft)	Bandwidth, Mbps	PoE Load Capacity, W	Hi-PoE Load Capacity, W	Working Mode
100 (328)	100	25.5	50	IEEE/E100
200 (656)	100	25.5	30	E100
300 (984)	100	18	18	E100
400 (1312)	100	15	15	E100
500 (1640)	10	12	12	E10
800 (2625)	10	6	6	E10
1000 (3281)	10	5	5	E10

**Via RG-59 Coaxial Cable**

ePoE supply voltage 53 V  
Maximum DC resistance < 5 Ω/100 m

Cable Length, m (ft)	Bandwidth, Mbps	PoE Load Capacity, W	Hi-PoE Load Capacity, W	Working Mode
100 (328)	100	25.5	52	IEEE/E100
200 (656)	100	25.5	48	E100
300 (984)	100	25.5	30	E100
400 (1312)	100	20	23	E100
500 (1640)	10	16	16	E10
800 (2625)	10	10	10	E10
1000 (3281)	10	8	8	E10



**Ordering Information**

Type	Part Number	Description
4 MP Camera	N45CB5Z	4 MP IR ePoE, Vari-focal Bullet Network Camera, True WDR, IVS
Mounting Accessories, optional	PFA121	Junction Box
	PFA152-E	Pole Mount
	DH-PFM320D-015	12 VDC, 2 A Power Adapter
ePoE Accessories, optional	LR1002	EoC Passive Converter
	LR1002-1EC	Single-port EoC Receiver

**Accessories**

Optional:



PFA121  
Junction Box

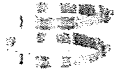

PFA152-E  
Pole Mount



DH-PFM320D-015  
Power Adapter



LR1002  
EoC Passive Converter



LR1002-1EC  
Single-port EoC Receiver

**ePoE Applications**

**Pure Ethernet**

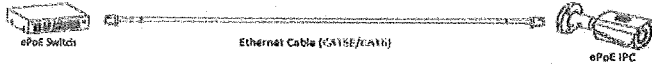

**Passive EoC**



**EoC with Single-port EoC Receiver**

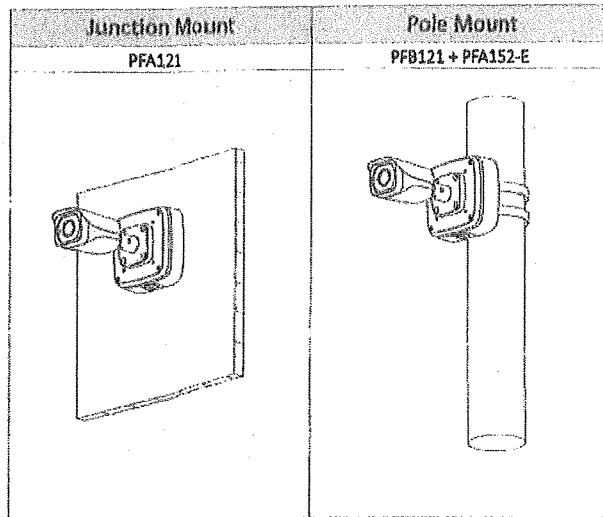

**Dimensions (mm/in.)**

273.20 mm  
(10.76 in.)

174.70 mm  
(6.88 in.)

100.0 mm  
(3.94 in.)

95.0 mm  
(3.74 in.)

95.0 mm  
(3.74 in.)

**Town of Newburgh**  
**Crossroads of the Northeast**  
**1496 Route 300**  
**Newburgh, NY 12550**

**Deborah A. Smith**  
**Receiver of Taxes & Assessments**

(Tel) 845-564-4553

(Fax) 845-566-1432

MEMORADUM

DATE: October 1, 2019  
TO: Gilbert Piaquadio, Supervisor  
FROM: Deborah A. Smith  
SUBJECT: 2019 Chargebacks

I am requesting to be on the October 15, 2019 Town Board Meeting Agenda for the approval of the 2019 Chargebacks and the signatures required for the Commissioner of Finance voucher.



# TOWN OF NEWBURGH

1496 Route 300  
Newburgh, New York 12550  
(845) 564-5220

G03200

DO NOT WRITE IN THIS BOX

DEPARTMENT **Tax Receiver**

CLAIMANT'S NAME AND ADDRESS  
Commissioner of Finance  
265 Main Street  
Goshen, NY 10924

TERMS \_\_\_\_\_

Date Voucher Received		VOUCHER NO.
FUND - APPROPRIATION	AMOUNT	
001.1964.0499	\$20,106.11	
030.1964.0499	\$10,794.22	
015.1964.499.1501	\$1,583.79	
040.1964.0499	\$3,309.51	
040.1964.0499	\$12,103.26	
Total		\$47,896.89
Abstract #		

Invoice # \_\_\_\_\_

Dates	Quantity	Description of Materials or Services	Unit Price	Amount
10/1/2019		2019 Charge Backs		\$47,896.89
			<b>TOTAL</b>	<b>\$47,896.89</b>

### CLAIMANT'S CERTIFICATION

I, \_\_\_\_\_ certify that the above account in the amount of \$ **\$47,896.89** is true and correct; that the items, services and disbursements charged were rendered to or for the municipality on the dates stated; that no part has been paid or satisfied; that taxes, from which the municipality is exempt, are not included; and that the amount claimed is actually due.

\_\_\_\_\_  
DATE SIGNATURE TITLE

(Space below for municipal use)

#### DEPARTMENT APPROVAL

The above services or materials were rendered or furnished to the municipality on the dates stated and the charges are correct.

#### APPROVAL FOR PAYMENT

This claim is approved and ordered for paid from the appropriations indicated above

Date Authorized Official

Date

Auditing Board

2019 Town of Newburgh  
Chargebacks

Date: As of September 9, 2019

TO: Town Board

FROM: Deborah A. Smith, Receiver of Taxes

PAGE 1

Subject	NAME	REASON	SBL	TOWN	HIGHWAY	Consol	Consol		TOTAL
							Consol Lt	WTR 1	
Watchtower		Court Order	95-1-45,22 & 97-2-30,12			953.56			953.56
Meadow Hill Realty		Court Order	60-3-51.1	15586.37	8343.52	630.23	2588.42	4519.82	31668.36
Potter		Correction of Error	47-1-103	113.47	65.80				179.27
Anello/Handier		Correction of Error	20-1-18.2	1.00				306.85	307.85
Leclair		Correction of Error	20-1-18.3	1.00				341.84	342.84
Great Palace		Court Order	86-1-39,21	3378.06	1800.85		561.14	979.96	6720.01
Patel		Correction of Error	20-1-18.55	1.00				453.1	454.10
Orr		Correction of Error	20-1-18.56	1.00				370.03	371.03
Fisher		Correction of Error	20-1-135	1.00				330.00	331.00
Colendrea		Correction of Error	20-1-136	1.00				33.98	34.98
Colendrea		Correction of Error	20-1-137	1.00				341.08	342.08
Ryan/Zoutis		Correction of Error	20-1-138	1.00				380.35	381.35
Zambio		Correction of Error	43-1-37	1.00				433.21	434.21
Beach		Correction of Error	43-1-38	1.00				415.34	416.34
Oliver		Correction of Error	43-1-39	1.00				41.28	42.28
Oliver		Correction of Error	43-1-40	1.00				565.11	566.11
Shah		Correction of Error	43-1-41	1.00				361.22	362.22
Choudhury		Correction of Error	43-1-42	1.00				468.7	469.70
Aftab		Correction of Error	43-1-43	1.00				415.34	416.34
Labor's Local 17		Correction of Error	97-1-40,2	1.00			3.28	5.64	9.92
Ness Group		Court Order	86-1-86	1008.21	584.05		156.67		1748.93
Levy		Correction of Error	20-1-18.4	1.00				327.49	328.49
Fuehck		Correction of Error	20-1-18.52	1.00				323.96	324.96
Dickinson		Correction of Error	20-1-18.53	1.00				302.57	303.57
Gonzalez		Correction of Error	20-1-18.54	1.00				386.39	387.39
<b>TOTAL</b>			Bal. Due	<b>20106.11</b>	<b>10794.22</b>	<b>1583.79</b>	<b>3309.51</b>	<b>12103.26</b>	<b>47896.89</b>



**Town of Newburgh**  
*Crossroads of the Northeast*  
1496 Route 300  
Newburgh, NY 12550  
*Deborah A. Smith*  
Receiver of Taxes and Assessments

Phone 845-564-4553

Fax 845-566-1432

DATE: September 24, 2018  
TO: Gilbert Piaquadio, Supervisor  
FROM: Deborah A. Smith, Receiver of Taxes  
SUBJECT: 2019 Unpaid Sewer Bond Relevy

I am requesting to be on the October 15, 2019 Town Board Meeting for the approval of unpaid Sewer Bond Relevy for the 2020 Property Taxes.

I will provide backup to the Town Clerk.

At a meeting of the Town Board  
Town of Newburgh, Orange County,  
New York, Held at the Town Hall,  
1496 Route 300, Town of Newburgh  
New York on the 15<sup>th</sup> day of  
October, 2019

PRESENT:  
Gilbert J. Piaquadio, Supervisor  
Elizabeth J. Greene, Councilwoman  
Paul I. Ruggiero, Councilman  
James E. Presutti, Councilman  
Scott Manley, Councilman

RESOLUTION LEVYING UNPAID  
SEWER BOND CHARGES AND  
ASSESSMENTS

Councilman presented the following resolution which was seconded by Councilman

WHEREAS, the Supervisor of the Town of Newburgh, on October 15, 2019 transmitted to the Board, a statement of the Unpaid Sewer Bond Charges and Assessments filed with the Town Board of the said Town by Receiver of Taxes and Assessments. The papers contained a brief description of the property on which the sewer bond charges and assessments are unpaid, the names of persons or corporation liable to pay the same and the amounts chargeable to each, and

BE IT RESOLVED, that there be levied on the 2019 tax roll of the Town of Newburgh against the properties hereinafter described as the Unpaid Sewer Bond in the amount of \$37,516.74 so transmitted to this Board and that the amount thereof is set forth on the tax roll of the said Town of Newburgh under the name

“UNPAID SEWER BOND” to wit (see schedule attached hereto) and

\*Town of Newburgh portion      \$ 37,516.74

BE IT FURTHER RESOLVED, that the amount so levied shall be placed in the warrant of the Orange County Legislature to the Receiver of Taxes of the said Town of Newburgh, and that the sewer charges and assessments levied shall be collected and paid to the Supervisor of the Town of Newburgh in the same manner as general taxes until the amount thereof is paid. The question of the adoption of the foregoing resolution was duly put to a roll call vote which resulted as follows:

Elizabeth J. Greene, Councilwoman	VOTING
Paul I. Ruggiero, Councilman	VOTING
James E. Presutti, Councilman	VOTING
Scott Manley, Councilman	VOTING
Gilbert J. Piaquadio, Supervisor	VOTING

The resolution was thereupon declared duly adopted.

**Town of Newburgh**  
*CrossRoads of the Northeast*  
1496 Rt 300  
Newburgh, NY 12550

Date: September 30, 2019  
To: Gilbert Piaquadio, Supervisor  
From: Deborah A. Smith, Receiver of Taxes  
Subject: Relevy Unpaid Sewer Bond

Attached are the delinquent Sewer Bond Accounts in the Town of Newburgh from July 1, 2018 through June 30, 2019. Accounts are to be transferred to the County and Town Roll. A Resolution requesting the Orange County Legislature to authorize the procedure is attached. The total to be relieved is \$37,516.74. The following breakdown applies:

	District #	
Algonquin	50	\$0.00
Crossroads & Colden Pk	51 & 58	\$10,213.87
Outsider User- CR	52	\$6,949.06
Gidney	53 & 54	\$0.00
Meadow Hill No	55	\$0.00
Meadow Hill So	56	\$5,769.07
Rt 17K/UA	57	\$0.00
Fleetwood	59	\$379.73 * 2018 3rd & 4th Qt.
Outside User- Gid	60	\$0.00
Wintergreen	61	\$3,372.65
Sherwood Forest	62 & 63	\$2,162.98
Pine Brook/Nbg Gdn	64 & 65	\$4,637.59
Orange Lake	66	\$2,654.48
Stewart Heights	67	\$1,377.31
Total		\$37,516.74

cc: Joseph Pedi, Town Clerk  
Ronald Clum, Accountant

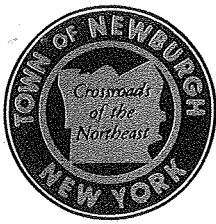

# TOWN OF NEWBURGH

20

1496 Route 300, Newburgh, New York 12550

**RONALD E. CLUM, CPA**  
ACCOUNTANT

845-564-5220

Fax: 845-566-9461

E-Mail: [rdumaccountant@townofnewburgh.org](mailto:rdumaccountant@townofnewburgh.org)

**To:** Gil Piaquadio, Town Supervisor  
**CC:** Town Board  
**From:** Ronald E. Clum, Town Accountant  
**Date:** October 11, 2019  
**RE:** Justice Court Unclaimed Bail

Attached is a list of the Unclaimed Exonerated Bail accounts (T-89) that are over six years old. Justice Court made a good faith effort to locate the persons that posted bail before the funds were turned over to the Accounting Department. These funds are still unclaimed 6 years later. At this time the bail becomes the property of the municipality and will be recorded as miscellaneous revenue. Please approve the transfer of these funds amounting to \$5,366.55 to the general fund.

7/17/2013	Randahl Schmidt	65.00
7/17/2013	O'Shane Miller	50.00
7/17/2013	Timothy Fischer	100.00
Total		
7/19/2013	Robin, McCarthey	194.00
7/19/2013	Ralph, Cefalo	135.80
7/19/2013	Lamont, Campo	39.00
7/19/2013	Deborah, Ramos	290.32
7/19/2013	Brittany, Shay	100.00

7/19/2013	Miroslaw, Jozwiak	94.00
7/19/2013	Tyrone, Testman	39.00
7/19/2013	Jose, Crespo	50.00
7/19/2013	Javier, Moreno	850.00
7/19/2013	Marcus, Brown	4.00
7/19/2013	Frank, Harrison	29.00
7/19/2013	Paul, Williams	194.00
7/19/2013	Gilda, Mendoza	100.00
7/19/2013	Elizabeth, Alonso	100.00
7/19/2013	Feliciano, Rodriguez-T	50.00
7/19/2013	Christian, Santo- Rivera	140.00
7/19/2013	Thomas, Victor	50.00
7/19/2013	George, Burks	15.00
7/19/2013	John, Katonah	170.00
7/19/2013	Donchevell, Nugent	100.00
7/19/2013	Deirdre, Multari	750.00
7/19/2013	Justin, Debrosky	153.00
7/19/2013	Michael , McLean	175.00
7/19/2013	Nicole, Petrone	5.00
7/19/2013	Jason, Shah	235.00
7/19/2013	Frank, Salomani	23.00
7/19/2013	Brett, Copeland	20.50
7/19/2013	Jesus, Aviles	



		97.00
7/19/2013	Michael, Tomadelli	35.00
7/19/2013	Eli, Muniz	44.00
7/19/2013	David, Bailin	75.00
7/19/2013	Unidentified Funds	122.07
Total		
7/19/2013	Michael, Garmer	67.20
Total		
8/23/2013	Unidentified Funds	605.66