

*ANDREW J. ZARUTSKIE, Town Clerk
1496 Route 300
Town of Newburgh, New York 12550
Telephone 845-564-4554*

**PUBLIC MEETING AGENDA
Monday, August 4, 2014
7:00 p.m.**

- 1. ROLL CALL**
- 2. PLEDGE OF ALLEGIANCE TO THE FLAG**
- 3. MOMENT OF SILENCE**
- 4. CHANGES TO AGENDA**
- 5. APPROVAL OF AUDIT**
- 6. (7:00 p.m.) PUBLIC HEARING: Amending Zoning for Banks in IB Zone**
- 7. (7:15 p.m.) PUBLIC HEARING: Unsafe Building at 1816 Route 300**
- 8. REPORT FROM DEPARTMENT HEADS**
- 9. IDA RESOLUTION**
- 10. ENGINEERING:**
 - A. 2014 Capital Improvements**
 - B. Delaware Aqueduct Tap WJP Materials Bid**
- 11. BUILDINGS & GROUNDS:**
 - A. Windows at Town Hall**
 - B. Bid of Generator for Town Hall**
- 12. HIGHWAY: Installation of Guard Rail (Powder Mill Road)**
- 13. JUSTICE COURT:**
 - A. Hiring of Court Clerk (Martini)**
 - B. Begin Process to Hire New Court Clerk (Clarino)**
- 14. RECREATION:**
 - A. T-38 Withdrawal**
 - B. Request for Use of Chadwick Park**
- 15. ANIMAL CONTROL: T-94 Withdrawal**
- 16. ACCOUNTING: Approval of Additional Funds for Financial Audit**
- 17. DISTRICT ATTORNEY OFFICE: Appoint a Tn Bd Member to Advisory Board**
- 18. EMPLOYEE ASSISTANCE PROGRAM**
- 19. ANNOUNCEMENTS**
- 20. PUBLIC COMMENTS**
- 21. POTENTIAL OF EXECUTIVE SESSION: ZBA Applicants & Attorney Selection**
- 22. ADJOURNMENT**

**TOWN OF NEWBURGH
 INTRODUCTORY LOCAL LAW NO. 6 OF 2014
 AMENDING CHAPTER 185 ENTITLED "ZONING" OF THE
 CODE OF THE TOWN OF NEWBURGH
 TO PROVIDE FOR BANKS AS A PERMITTED
 PRINCIPAL USE SUBJECT TO SITE PLAN REVIEW
 IN THE IB ZONING DISTRICT
 AND FOR SUPPLEMENTARY REGULATIONS FOR
 BANKS WITH DRIVE-THRU WINDOWS**

BE IT ENACTED by the Town Board of the Town of Newburgh, County of Orange, as follows:

SECTION 1 – TITLE

This Local Law shall be referred to as "A Local Law Amending Chapter 185 entitled 'Zoning' of the Code of the Town of Newburgh to Provide for Banks as a Permitted Principal Use Subject to Site Plan Review in the IB Zoning District and for Supplementary Regulations for Banks with Drive-thru Windows".

SECTION 2 – PURPOSE AND INTENT

The purpose of this local law is to permit banks as a principal use in the Interchange Business (IB) District subject to site plan review by the Planning Board. For purposes of this Local Law and the Zoning Code, the term banks shall include credit unions. Banks have been permitted in the IB District as part of shopping centers. The Town Board declares its intent to permit banks as a principal use subject to site plan review in the IB District without a requirement that the bank use be proposed in conjunction with a shopping center. The Board finds that the bank use is similar to and consistent with other principal commercial uses already separately permitted in the IB District. The Local Law also adds supplementary regulations for banks with drive-thru windows which are substantially similar to the existing supplementary regulations for drive-thru establishments.

SECTION 3 – AMENDMENTS TO CHAPTER 185

1. Chapter 185, "Zoning" of the Code of the Town of Newburgh, Table of Use and Bulk Requirements for the IB Zoning District, Schedule 8 of the Code adopted and incorporated into the Code pursuant to §185-10 entitled "Utilization of Use Table" and §185-11 entitled "Utilization of Bulk Table" shall be amended as follows:

A. Number 5 of Column D entitled "Uses Subject to Site Plan Review by the Planning Board" shall be amended to read as follows:

“5. Offices for business, research and professional use
and banks.”

2. A new Section 185-45.6 entitled “Banks with drive-thru windows” is hereby added to Chapter 185 entitled “Zoning” of the Code of the Town of Newburgh to read as follows:

“§185-45.6 Banks with drive-thru windows.

Before approving any bank with a drive-thru window, the Planning Board shall consider:

(1) Vehicular traffic movements and potential hazards to pedestrian safety. All drive-thru aisles shall exit into a parking area, driveway or onto a side street and not directly onto Routes 9W, 17K, 32, 52 or 300.

(2) Proposed signs, lighting, speaker noise where residential properties are located nearby and landscaping.

(3) Public roads and internal drive aisles shall not be blocked by waiting drive-thru traffic.

(4) Parking areas and circulation drives shall be adequately separated so as to avoid conflict between parking cars and waiting drive-thru traffic.

(5) Adequate stacking space will be provided for waiting drive-thru vehicles such that these vehicles do not interfere with site vehicular or pedestrian circulation.

(6) The site plan checklist for parking lot area traffic and pedestrian movements/safety concerns shall be reviewed in preparation of plans.”

SECTION 4 – VALIDITY

If any word, clause, sentence, paragraph, section or part of this local law or the application thereof to any person or circumstance shall be adjudged by any court of competent jurisdiction to be unconstitutional, illegal or invalid, such judgment shall not affect, impair or invalidate the remainder thereof or the application thereof to any other persons or circumstances but shall be confined in its operation to the clause, sentence, paragraph, word, section or part thereof directly involved in the controversy in which such judgment shall have been rendered. The Town Board hereby declares that it would have enacted this Local Law or the remainder thereof if the invalidity of such provision or application thereof had been apparent.

SECTION 5 – EFFECTIVE DATE

This Local Law shall take effect immediately when it is filed in the Office of the New York State Secretary of State in accordance with Section 27 of the Municipal Home Rule Law.

#2 7-

Unsafe Building
Town of Newburgh
Tax Map Section: 14-1-19
Code Compliance Department
Town of Newburgh
308 Gardnertown Rd.
Newburgh, New York 12550

Dear Frank and Olive Balison,

With reference to the above described property, the house has been declared by the Town Board of the Town of Newburgh to be unsafe due to structural instability and partial collapse.

This notice as of this date includes an ORDER to make safe and secure or to remove said building shall commence within twenty (20) days of the serving notice as hereinafter provided, and shall be completed within forty – five (45) days thereafter.

That in the event of neglect or refusal of the persons served with this notice and order to comply with same, the Town Board will cause said building to be demolished and removed.

That the land on which said buildings or structures are located will be assessed for all costs and expenses incurred by the Town in connection with the proceedings to remove or secure including the cost of actually removing the said building or structure and/or a special proceeding to collect said cost including legal fees, may be instituted by the Town Board.

That on the 4th ,day of August 2014 at 7:00pm, at the Town Hall, 1496 Rte. 300 in the Town of Newburgh, a hearing will be held before the Town Board at which time and place you will be given an opportunity to be heard in response to the evidence presented by the Town.

Attached is a certified copy of the “Resolution Determining Unsafe Building and Order to Make Safe or Remove” as passed by the Town Board, Town of Newburgh, on the 23rd day of July 2014.

This was certified by the Town Clerk on the 24th day of July 2014

Your full cooperation in this matter will be appreciated and expected.

Dated: July 24, 2014

Thomas Dubetsky
Public Safety Officer
Town of Newburgh

August
Frank 7:15

At a meeting of the Town Board
held at 1496 Rte. 300, in the Town of
Newburgh on the 23rd day of
July 2014 at 7:00 pm

Present:

Elizabeth Greene, Councilwoman
Gilbert Piaquadio, Councilman/Acting Supervisor
Paul Ruggiero, Councilman
George Woolsey, Councilman

**RESOLUTION DETERMINING
UNSAFE BUILDINGS AND
ORDER TO MAKE SAFE OR
REMOVE**

WHERE AS, it was reported to the Town Board that a house addressed as 1816 Rte. 300 .
in the Town of Newburgh owned by Frank and Olive Blaison, said premises designated
as Section 14, Block 1, Lot 19 , might be dangerous or unsafe to the public and

WHERE AS, the Town Board ordered the Code Compliance Dept. to make an inspection
and report of said site, and

WHERE AS, the Code Compliance Dept. did so inspect and deliver a report on said
building to said Town Board on the 23rd , day of July, 2014 and

WHERE AS, the Town Board has carefully considered said report.

NOW, THEREFORE, BE IT RESOLVED, that the Town Board of the Town of
Newburgh declares that the house located on a portion of 1816 Rte.300 premises owned
by Francis and Olive Blaison.said premises designated as Section 14, Block 1, Lot 19 is
unsafe and dangerous and comes within the confines of Chapter 75, Subsection 2, of the
Town of Newburgh Municipal Code.

BE IT FURTHER RESOLVED AND ORDERED, that said building shall be made safe
or removed and that work shall commence within (20) days of the serving of notice of
this Resolution and shall be completed (45) days thereafter.

BE IT FURTHER RESOLVED AND ORDERED THAT a notice containing the
information required under Section 75.2 C and E.

The foregoing resolution was duly put to a vote on roll call which resulted as follows:

Elizabeth Greene voting
Gil Piaquadio voting
Paul Ruggerio voting
George Woolsey voting

WHERE AS, a Public Hearing has been scheduled for the 4th of August 2014 at 7:00 pm for the hearing of all disputes and challenges to the claiming of Unsafe Building status for the house listed as 1816 Rte. 300 in the Town of Newburgh.

TOWN OF NEWBURGH

Crossroads of the Northeast

OLD TOWN HALL
308 GARDNERTOWN ROAD
NEWBURGH, NEW YORK 12550

CODE COMPLIANCE DEPT.
TELEPHONE 845-564-7801
FAX LINE 845-564-7802

July 21, 2014

To: Gil Piaquadio, Acting Town Supervisor
Town Board Members
From: Thomas Dubetsky
Asst. Fire Inspector/ Safety Officer
Re: Unsafe Building Resolution
SBL 14-1-19
1816 Rte. 300.

Based on an inspection of the residential structure on the above indicated parcel it is the recommendation of this office that an Unsafe Building Resolution be adopted.

Town of Newburgh Municipal Code Section 75-2

C. "Those which have improperly distributed loads upon the floors or roofs or in which the same are overloaded or which have insufficient strength to be reasonably safe for the purpose used.

Actual conditions:

Roof partially collapsed

E. "Those which have become or are so dilapidated, decayed, unsafe, or unsanitary or which so utterly fail to provide the amenities essential to decent living that they are unfit for human habitation or are likely to cause sickness or disease so as to work injury to the health, morals, safety or general welfare of those living therein.

Actual conditions:

Excessive signs of decay to the structure .

In consideration of this report I request the adoption of an Unsafe Building Resolution and the scheduling of a Public Hearing on August 4, 2014. at 7pm

Respectfully submitted,



Thomas Dubetsky
Asst. Fire Inspector/ Safety Officer
Town of Newburgh



1816 Route 300







Gil Piaquadio <councilmanpiaquadio@townofnewburgh.org>

Unsafe Building Resolution Requests

1 message

Tom Dubetsky <townsafety@townofnewburgh.org>

Wed, Jul 16, 2014 at 1:40 PM

To: councilmanpiaquadio@townofnewburgh.org

Cc: fireinspector@townofnewburgh.org

Gil,

I would like to request that the following proposed Unsafe Buildings be placed on the agenda of the Town Board Audit Meeting for July 23, 2014.

1. 258 North Plank Road
2. 1816 Rte.300

Thank you

Thomas J. Dubetsky

Asst. Fire Inspector/Safety Officer

Town of Newburgh

Office- (845) 564-7801

Fax – (845) 567-7802

e-mail: townsafety@townofnewburgh.org



TOWN OF NEWBURGH

1496 Route 300, Newburgh, New York 12550

GIL PIAQUADIO
Deputy Supervisor
Acting as Supervisor

845-564-4552
Fax: 845-566-9486
e-mail: councilmanpiaquadio@townofnewburgh.org

James R. Petro, Jr.
Executive Director
Orange County Industrial Development Agency
4 Crotty Lane Suite 100
New Windsor, New York 12553

August 4, 2014

Re: Danskammer Power Plant Project; Application of Danskammer Energy
LLC/Mercuria Energy America Inc.

Dear Director Petro and Board Members:

Please let this letter serve to confirm our support for the application to the Orange County Industrial Development Agency of Danskammer Energy LLC for the Danskammer power plant in the Town of Newburgh, so that a "deviation" Payment in Lieu of Taxes ("PILOT") agreement containing terms and conditions substantially the same as those set forth in the enclosed term sheet may be executed. The PILOT agreement will not only ensure a stabilized income stream to each of the affected taxing jurisdictions, but will also facilitate the creation or preservation of approximately 45 permanent private sector jobs as well as several jobs associated with the repair and rehabilitation work. The project will also provide additional host community revenues to the Town.

We are excited about the Danskammer power plant's reopening following its shut down after being damaged by Superstorm Sandy. The reopening of the power plant will assist in ensuring that our region has the vital and affordable electricity necessary for our economic well-being and will reduce emissions from the levels proposed when Danskammer operated on coal. The project fits well with the Town's Industrial zoning, and will provide a significant benefit to our region. We understand that the proposer seeks to immediately commence the refitting of the power plant, and will be working diligently towards resuming the plant's operation.

We appreciate any assistance and incentives that the Orange County IDA may provide, including the deviation PILOT agreement. The project represents a prime example of a private sector recovery from Superstorm Sandy's damage with minimal governmental assistance and without the tax dollar support required for so many other restorations in the surrounding region.

Thank you for your consideration.

GJP/ Enc.

CC: Steven Neuhaus, County Executive
Wayne C. Booth, Deputy County Executive
Town Board Members
Town Clerk
Town Assessor
David Murphy, Esq.

Sincerely,
Town of Newburgh

By: _____
Gilbert J. Piaquadio
Deputy Supervisor

EXHIBIT B

Inputs	Orange City	Twin Newburgh	Mailboro CSD	
Proposed (2015) Ass. Roll Yr. Tax Payment				\$ 1,500,000.00
Current (2014) Ass. Roll Yr. Combined Tax Rate/k*				\$ 90.18
Annual Property Tax Increase:				2.00%
County Portion of Annual Property Tax:				10.89%
Town Portion of Annual Property Tax:				14.19%
School District Portion of Annual Property Tax:				74.92%
	1,500,000.00	212,850.00	1,123,800.00	1,500,000.00
2015	166,617.00	217,107.00	1,146,276.00	1,530,000.00
2016	169,949.34	221,449.14	1,169,201.52	1,560,600.00
2017	173,348.33	225,878.12	1,192,585.55	1,591,812.00
2018	176,815.29	230,395.68	1,216,437.26	1,623,648.24
2019	180,351.60	235,003.60	1,240,766.00	1,656,121.20
2020	183,958.63	239,703.67	1,265,581.32	1,689,243.63
2021	187,637.80	244,497.74	1,290,892.95	1,723,028.50
2022	191,390.56	249,387.70	1,316,710.81	1,757,489.07
2023	195,218.37	254,375.45	1,343,045.03	1,792,638.85
2024	1,788,636.92	2,330,648.11	12,305,296.44	16,424,581.47
Total				

*Exclusive of Special District Assessments/Taxes

EXHIBIT A

Basic Terms

- Danskammer commits to a 10-year PILOT with two (2) annual payments per year, the first payable by September 30 and the second by January 31 of the following calendar year, in the initial aggregate amount of \$1.5 million, with annual 2% escalation provision.
- The September payment each year shall reflect the percentage amount payable to the Marlboro School District and the January payment each year shall reflect the percentages due to the Town of Newburgh and Orange County.
- PILOT payments shall not increase during the PILOT term, irrespective of the actual assessment of the project or any assessment changes due to improvements or upgrades, provided that such improvements do not increase facility generation capacity beyond current nameplate capacity rating.
- PILOT payments shall be split annually between the taxing jurisdictions based on current tax revenue percentages (i.e. 2014 Town/County taxes and 2013/14 school district taxes).
- Danskammer shall pay all special district charges on or before the dates due, but the PILOT shall provide that for the aggregate special district charges paid by Danskammer in any calendar year greater than a base amount of \$120,000, which base shall escalate 2% per year, such excess shall be credited against the next PILOT payment amount.
- PILOT is assignable to any successor owner(s), which shall assume the PILOT/IDA leasehold, as well as existing indemnification obligations, and Danskammer will be released from any continuing obligations after.
- Danskammer shall make all regular tax payments resulting from the Town's final 2014 assessment roll.

10A

TOWN OF NEWBURGH
CONSOLIDATED WATER DISTRICT
ORANGE COUNTY, NEW YORK

2014 WATER SYSTEM
CAPITAL IMPROVEMENTS

PREPARED FOR:

Town of Newburgh
1496 Route 300
Newburgh, NY 12550

TOWN OF NEWBURGH
CONSOLIDATED WATER DISTRICT

2014 WATER SYSTEM
CAPITAL IMPROVEMENTS

I. INTRODUCTION

The Town of Newburgh Consolidated Water District (TONCWD) has identified several capital project improvements necessary to be completed. These projects include the following:

1. Stewart Airport Water Storage Tank Painting and Improvements;
2. Fletcher Drive Water Main Extension and Meadow Hill Road / Route 52 Pumping Station Improvements;
3. Chadwick Lake Filter Plant Roof Replacement;
4. Water System Meter Replacement Program.

A detailed description of each of these projects and their associated costs are given below.

II. PROJECT DESCRIPTION

A. Stewart Airport Water Storage Tank Painting and Improvements:

The Stewart Airport Water Storage Tank is a welded steel tank located on Assembly Way in the Stewart Airport Industrial Park. The tank was erected in 1991 and has the original paint/coating system. Since its construction, the Town has leased space on the tank to four cellular phone carriers. The property on which the tank is located is an easement granted from the New York State Department of Transportation.

The Town of Newburgh engaged the service of GHD Consulting Engineers to conduct an inspection of the condition of the 1.8 Million Gallon Stewart Airport Water Storage Tank. In addition, GHD was tasked with evaluating and recommending a corrosion control technology, rehabilitation of an existing re-chlorination facility, a technology for the reduction of Total Tri-Halomethanes (TTHM) – a disinfection by-product, a method/technology for mixing the water in the tank, and a method to integrate the tank into the Town's SCADA system.

In March 2013, GHD issued a report entitled *Engineering Services for 1.8 MG Stewart Airport Water Storage Tank – Final Report*.

In the report, GHD evaluated alternatives and made recommendations to address the deficiencies in the condition of the existing tank coatings and to implement the water quality and operational improvements requested by the Town. Their specific recommendations are as follows:

1. The tank interior should be sand-blasted to Society of Protective Coating SP-10 (near white blast cleaning) and recoated with a 100 percent solids zinc/epoxy paint system.
2. The tank exterior should be sand-blasted to SP-6 (commercial blast cleaning) and recoated with an Extended Performance System of a three coat zinc/epoxy/urethane paint system.
3. For corrosion control, GHD recommended the use of a zinc rich primer for the tank interior (included in Item 1 above) rather than the use of a cathodic protection system.
4. To provide for the addition of chlorine into this part of the water distribution system to offset low chlorine residuals, GHD recommends the installation of new equipment in the existing on-site structure consisting of a weight scale, chlorine residual analyzer, metering pump skid, safety shower and eye wash, chemical injection assembly and a flow meter.
5. To reduce the TTHM levels, specifically chloroform levels in the water in the Stewart Airport Water Storage Tank, GHD has recommended the installation of a Solar Bee tank mixing system to provide turnover in the tank and reduce the water age. The need for a TTHM reduction system would be determined based on operational data with the mixing system in place.
6. To connect the Stewart Airport Water Storage Tank to the Town's existing SCADA system, GHD has recommended the installation of a cellular modem and a PLC based control panel.
7. To partially mitigate the loss of available fire flow to the Town's high pressure zone, GHD has recommended the installation of a connection between the Meadow Winds Tank and the Meadow Hills Tank controlled by a pressure reducing valve. The connection between the two service areas would be made on the west side of Meadow Hill Road near Fletcher Drive.

The total estimated cost for these improvements is **\$2,008,000** as shown on Table 1.

Table 1

Estimated Costs – Stewart Airport Tank Projects

Tank Painting (Extended Performance System)	\$1,140,000
Contingency	230,000
Engineering, Legal, Admin.	<u>210,000</u>
SUB-TOTAL:	\$1,580,000
Re-Chlorination Facility	\$ 100,000
Contingency	20,000
Engineering, Legal, Admin.	<u>20,000</u>
SUB-TOTAL:	\$ 140,000
TTHM Removal System	\$ 70,000
Contingency	14,000
Engineering, Legal, Admin.	<u>14,000</u>
SUB-TOTAL:	\$ 98,000
Tank Mixing System	\$ 30,000
Contingency	6,000
Engineering, Legal, Admin.	<u>6,000</u>
SUB-TOTAL:	\$ 42,000
Telemetry	\$ 17,000
Contingency	4,000
Engineering, Programming, Legal & Admin.	<u>16,000</u>
SUB-TOTAL:	\$ 37,000
Interconnection / PRV	\$ 80,000
Contingency	16,000
Engineering, Legal & Admin.	<u>15,000</u>
SUB-TOTAL:	\$ 111,000
TOTAL:	\$2,008,000

B. Fletcher Drive Water Main Extension and Meadow Hill Road / Route 52 Pumping Station Improvements.

As part of the Engineering Services for the 1.8 MG Stewart Airport Water Storage Tank Report, GHD evaluated distribution system improvements that would result in an increased operating range for the Meadow Hill and Stewart Airport Tanks. This operational adjustment will reduce pumping costs and improve the water quality in the distribution system.

Their recommendation was to transfer a portion of the Route 17K / Meadow Hill service area at the top of Meadow Hill to the service area served by the higher Meadow Winds tank. This could be accomplished by connecting the existing 12-inch main extending from Hibbing Way down North Fletcher Drive to the water main in Amber Drive. This would allow approximately 70 homes to be included in the Meadow Winds Service Area and allow the operating levels in the Meadow Hill / Stewart Airport Tanks to increase their operating range. The proposed project consists of the installation of approximately 2500 linear feet of 8-inch diameter ductile iron water main including transferring existing services onto the new main.

In addition, the report recommended the installation of flow meters in the Meadow Hill Road and Route 52 Water Booster Pumping Stations. This would allow the Town to monitor demand in this part of the system.

The total estimated cost for these improvements is \$492,300 as shown in Table 2 below:

Table 2

ESTIMATED PROJECT COSTS

Fletcher Drive W.M. Extension	\$ 320,000
Flow Meter Installation	35,000
Contingency	72,000
Engineering, Legal & Admin.	<u>65,000</u>
TOTAL:	\$ 492,300

C. Chadwick Lake Filter Plant Roof Replacement

The age of the existing roof on the Chadwick Lake Filter Plant is unknown. However, recent leaks into the pump room have prompted an inspection of the condition of the roof. Based on the inspection, it is recommended that the existing membrane roof be removed and replaced with a new membrane roof.

The cost estimate for this work is \$230,000 including engineering, legal and administrative costs.

D. Water System Meter Replacement Program

In the past few years, the Town of Newburgh has begun the process of upgrading its customers' meters. The Town has selected a radio read head to be installed on compatible Badger meters and replacement of non-compatible meters with new Badger meters with radio read heads. The goal is to modernize its meter reading operations, reducing labor costs of meter reading, improving the accuracy of its meter reads and improving the revenue stream of both the TONCWD and associated Sewer Districts.

To date, approximately 1200 of the Town's 6600 accounts have been upgraded to the new meter reading technology. However, recognizing that a complete retrofit of its customers' meters would take 5 years or more, and recognizing that a significant number of its customer meters are 25 to 40 years old and well past their projected useful life, the Town of Newburgh has elected to fund the replacement of the remaining 5400 meters and hire a specialized contractor to undertake the installation of the new meters and heads.

The estimated cost of this project is \$1,500,000.

III. SUMMARY OF PROJECT COSTS

For the four projects discussed above, the combined project costs are as follows:

A. Stewart Airport Tank Improvements	\$2,008,000
B. Fletcher Drive W.M. Ext.\P.S. Upgrades	492,300
C. Chadwick Lake Filter Plant Roof	230,000
D. Meter Replacement Program	<u>1,500,000</u>
TOTAL:	\$4,230,300

IV. PROJECT FINANCING

The Town intends to use some existing available monies and bonding to pay for the improvements identified in this Report. A breakdown of monies available for use for these projects consist of the following:

Stewart Airport WST Capital Project	\$ 850,000
Capital Reserve Fund	<u>400,000</u>
Total Available Funds:	\$1,250,000

The total project cost of \$4,230,300 minus the currently available funds of \$1,250,000 leaves an amount of \$2,980,300 to be bonded.

The calculated principal and interest payment for a 20 year bond at an interest rate of 2.5 percent is \$223,525.

Payment of the principal and interest payment can be made either from the TONCWD's Water 1 and Water 2 charges which are based on the Assessed Value of the individual properties in the Water District, or because of the inclusion of the meter replacement program, payment could be made utilizing an increase in the water usage rates. Each of these methods is discussed below.

Water 1 and Water 2 Repayment

Utilizing Water 1 and Water 2 charges for repayment of the principal and interest would result in an increase in these charges of \$0.14 / 1000 AV as shown below:

$$\$223,525 / (924,685.866 + 703,935.849) = \$0.14 / 1000 \text{ AV}$$

For an average district property (single family home with an AV of \$85,000), the net increase in their W1/W2 bill would be approximately twenty four (24) dollars.

Water Usage Repayment

Utilizing water usage rates for repayment of the principal and interest would result in an increase in the water rates of approximately \$0.35 per thousand gallons as shown below:

$$\$223,525 / 640,000,000 = \$0.35 \text{ per thousand gallons}$$

For an average water user (75,000 gallons usage per year), their quarterly bill would increase by \$6.40 for a total annual increase of \$25.60.

This is slightly higher than using W1/W2 charges because the subset of district properties connected to the water distribution system is smaller than all the properties in the district. However, given that approximately 50 percent of the bond is being used for new water meter technology used by water consumers, this method only impacts district properties receiving a direct benefit.

10B

**TOWN OF NEWBURGH
TOWN ENGINEER
1496 Rte. 300
Newburgh, NY 12550
(845) 564-7814**

MEMORANDUM

TO: Gil Piaquadio, Deputy Supervisor & Town Board
FROM: James W. Osborne, Town Engineer *JWO*
DATE: August 1, 2014
RE: W\ DELAWARE AQUEDUCT TAP WTP

As discussed with the Town Board previously, we need to capture the water blown off from the membrane filters through the exhaust and vent lines and redirect it to the clarifiers for recycle. To that end, we solicited three price quotes to purchase the materials as follows:

Schmidt's Wholesale	\$ 11,039
Vellano Corporation *	\$ 11,575
Newburgh Winwater Works *	\$ 14,889

* QUOTES NOT 100% COMPLETE

Based on the above, I am requesting Town Board approval to purchase the required materials from Schmidt's at a purchase price of \$11,039.

As the above requires Town Board action, I am requesting that this item be placed on the next available agenda for approval. If you have any questions or comments, I am available to discuss them with you.

JWO/id

cc: J. Platt, DPW Comm.
R. Clum, Accountant

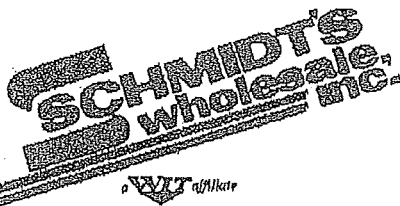

SCHMIDTS WHOLESALE, INC.

P.O. BOX 5100

MONTICELLO, NY 12701

WWW.SCHMIDTSWHOLESALE.COM

PRICE QUOTE

Phone 845-794-5900

Fax 845-794-8142

Page 1

Printed 07/22/14 REI

Quoted

Ship To

TOWN OF NEWBURGH
311 RT 32
NEWBURGH NY 12550
Tel:845-564-7813 Fax:845-566-8903

SAME

Quote #	Quote Date	Exp Date	Customer #	Customer P/O #	Ship Via	Writer
0042873	07/21/2014	08/20/2014	0000560		TRUCK	REI
Job ID	Customer Terms			Salesman		
PVCSCH80	NET 30 DAYS			TOM		
Product	Description	UM	Quant	Unit Price	Extension	
98036957000	6 X 20 PVC SCH80 PE PIPE PER	EA	6	120.7195	724.32	
98036958000	8 X 20 PVC SCH80 PE PIPE PER	EA	6	182.125	1092.75	
98037045860	6 PVC SCH80 VAN STONE FLG	EA	40	18.77	750.80	
98037040100	6 PVC SCH80 TEE	EA	10	41.37	413.70	
98037040760	6 PVC SCH80 SXS 90 ELL	EA	20	24.60	492.00	
98037041430	6 PVC SCH80 SXS 45 ELL	EA	10	29.57	295.70	
SP	8X6 PVC SCH80 WYE	EA	10	247.70	2477.00	
98037040102	8 PVC SCH80 SXSXS TEE	EA	4	95.94	383.76	
	SEE NOTE					
	* Above is a special order & *					
	* Non-Returnable item x: _____ *					
SP*067270	8 PVC SCH80 SXS 90 ELL	EA	2	67.80	135.60	
	806-080					
SP*041636	8 X 6 PVC SCH80 SXS CPLG	EA	2	134.04	268.08	
	SEE NOTE					
	* Above is a special order & *					
	* Non-Returnable item x: _____ *					
98037045870	8 PVC SCH80 VAN STONE FLG	EA	7	30.56	213.92	
SP	24X8 PVC SCH80 REDUCER	EA	1	2017.00	2017.00	
SP	6 HDPE IPS WELD FLANGE	EA	10	52.60	526.00	
SP	8 HDPE IPS WELD FLANGE	EA	1	92.40	92.40	
47011056044	6" FLG ACCESSORY KIT	EA	20	22.50	450.00	
47011056045	8" FLG ACCESSORY KIT	EA	7	25.00	175.00	
68439660465	Herc 60465 1QT Pvc Primer (CLEAR)	EA	12	11.2409	134.89	
68439660120	HERC 60120 1QT PVC CL CEMENT	EA	12	18.0912	217.09	
SP	8 PVC SCH80 BLIND FLANGE	EA	6	0.00	0.00	
98037042100	6 PVC SCH80 SXS CPLG	EA	6	20.50	123.00	
98037042102	8 PVC SCH80 SXS CPLG	EA	2	27.89	55.78	

Continue...

3

FILE: W\ DELAWARE AQUEDUCT TAP WTP

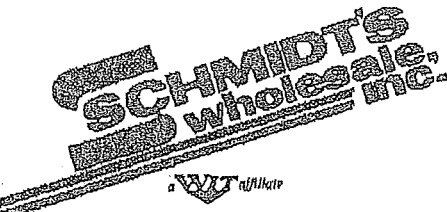

SCHMIDTS WHOLESALE, INC.
 P.O. BOX 5100
 MONTICELLO, NY 12701
 WWW.SCHMIDTSWHOLESALE.COM

PRICE QUOTE

Phone 845-794-5900
 Fax 845-794-8142

Page 2
 Printed 07/22/14 REI

Quoted
 TOWN OF NEWBURGH
 311 RT 32
 NEWBURGH NY 12550
 Tel:845-564-7813 Fax:845-566-8903

Ship To
 SAME

Quote #	Quote Date	Exp. Date	Customer #	Customer P/O #	Ship Via	Writer
0042873	07/21/2014	08/20/2014	0000560		TRUCK	REI
Job ID	Customer Terms			Salesman		
PVCSCH80	NET 30 DAYS			TOM		

Product	Description	UM	Quant	Unit Price	Extension

X: _____ (Accepted by)	Sub Total	\$11,038.79	Total \$11,038.79
	Freight	\$0.00	
	Misc Charges	\$0.00	
	Tax Amount	\$0.00	

<p align="center">MESSAGE</p> <p>Brass material with a lead content over 0.26% cannot be used in potable water systems per the Safe Drinking Water Act. We do not accept returns for any item exceeding 0.26% lead content.</p>	<p align="center">TERMS</p> <p>All special order items require a 50% minimum deposit and will be delivered immediately upon receipt of material.</p>
--	---

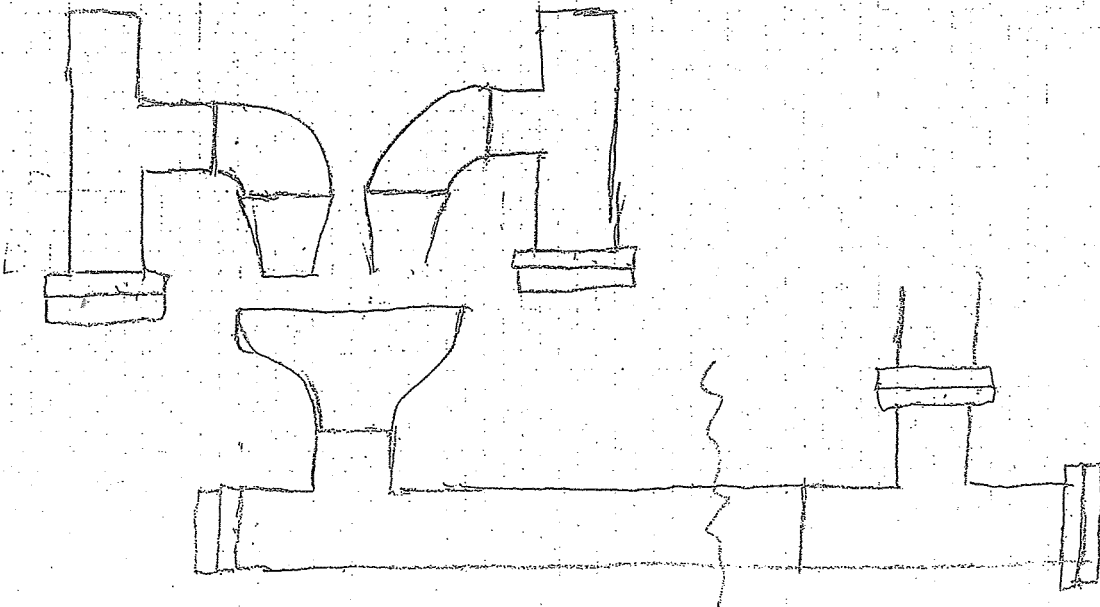
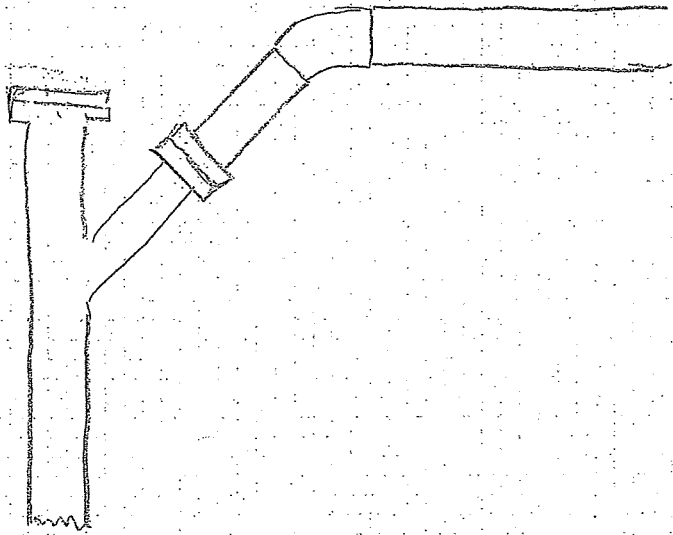
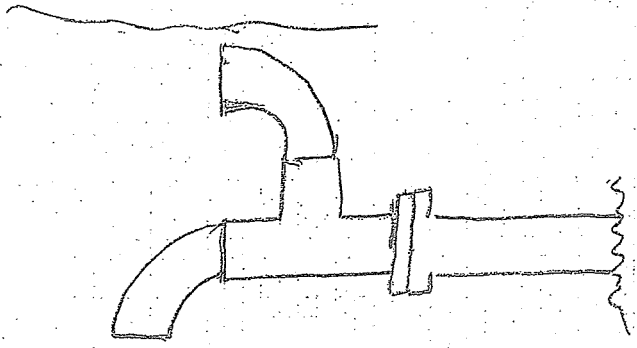

ATTN - MARY BUTLER

Jim
7-31-14

TOWN OF NEWBURGH
DELAWARE AQUEDUCT TAP WTP

REQUEST FOR QUOTE
VENT & EXHAUST PIPING MODIFICATONS

Page 1 of 1

VENDOR: THE VELLANO CORPORATION
CONTACT: GENE BOZSK
TEL. #: (845) 838-1010
E-MAIL: geneb@vellano.com

ITEM DESCRIPTION	UNITS	QUANTITY	UNIT PRICE	EXTENDED PRICE
6 X 20 PVC SCH80 PE PIPE PER	EA	6	6.00'	\$ 720.
8 X 20 PVC SCH80 PE PIPE PER	EA	6	9.10'	\$ 1092.
6 PVC SCH80 VAN STONE FLG	EA	40	17.62	\$ 704.80
6 PVC SCH80 TEE	EA	10	38.84	\$ 388.40
6 PVC SCH80 SXS 90 ELL	EA	20	23.10	\$ 462.
6 PVC SCH80 SXS 45 ELL	EA	10	21.75	\$ 217.50
8 X 6 PVC SCH80 WYE - 100 PSI *	EA	10	40.6	\$ 4060.
8 PVC SCH80 SXSXS TEE	EA	4	90.05	\$ 360.20
8 PVC SCH80 SXS 90 ELL	EA	2	63.64	\$ 127.28
8 X 6 PVC SCH80 SXS CPLG	EA	2	125.81	\$ 251.62
8 PVC SCH80 VAN STONE FLG	EA	7	32.12	\$ 224.84
24X8 PVC SCH80 REDUCER *	EA	1	1895.25	\$ 1895.25
6 HDPE IPS WELD FLANGE	EA	10	48.54	
8 HDPE IPS WELD FLANGE	EA	1		
6" FLG ACCESSORY KIT	EA	20	11.95	\$ 239.
8" FLG ACCESSORY KIT	EA	7	12.95	\$ 90.65
Herc 60465 1QT Pvc Primer (CLEAR)	EA	12	10.29	\$ 123.48
HERC 60120 1QT PVC CL CEMENT	EA	12	8.24	\$ 98.88
8 PVC SCH80 BLIND FLANGE	EA	6	48.54	\$ 291.24
6 PVC SCH80 SXS CPLG	EA	6	19.23	\$ 115.38
8 PVC SCH80 SXS CPLG	EA	2	26.17	\$ 52.34
TOTAL:				\$ 11,574.86

8x6 WYE
24x8 Reducer > 2-3 WEEKS
LEAD-TIME

SCH80 PVC FITTINGS -> FREE FREIGHT ON ORDERS OF
\$ 2,250. OR MORE TO ONE LOCATION.



VELLANO BROS., INC.

FAX
566-8903

FAX COVER SHEET

TO: *MARY BUTLER / JOHN PLATT*

LOCATION: *T/O Newburgh Water*

FROM: *GENE BOZSIK*

DATE: *7-31-14*

NUMBER OF PAGES (NOT INCLUDING COVER SHEET): *1*

IF YOU DO NOT RECEIVE ALL PAGES, CALL *(845)* 838-1010 EXT. 24

FAX NUMBER: *(845)* 838-1047

RE: Quote as requested.



Gene Bozsik
Municipal Sales Representative

Vellano Bros., Inc.
29 Vellano Drive, Wappingers Falls, NY 12590
845-838-1010
Fax: 845-838 1047 • Cell: 845-656-3129
geneb@vellano.com • www.vellano.com

Water | Sewer | Municipal | Drainage

Thanks
Gene
cell ph. 656-3129

1,074.0 +
 1,321.2 +
 1,070.4 +
 509.0 +
 655.8 +
 380.4 +
 4,718.9 +
 1,110.8 +
 147.96 +
 292.5 +
 261.8 +
 2,203.2 +
 193.0 +
 72.8 +
 149.28 +
 160.8 +
 338.7 +
 157.5 +
 70.5 +
 019.....
 14,888.54 ◊
 019.....
 14,888.54 *

REQUEST FOR QUOTE
VENT & EXHAUST PIPING MODIFICATONS

VENDOR: _____ NEWBURGH WINWATER WORKS
 CONTACT: _____ BRIAN STRATTON
 TEL. #: _____ 845-778-3312
 E-MAIL: BWSTRATTON@WINWATERWORKS.COM

<u>ITEM DESCRIPTION</u>	<u>UNITS</u>	<u>QUANTITY</u>	<u>UNIT PRICE</u>	<u>EXTENDED PRICE</u>
5 X 20 PVC SCH80 PE PIPE PER	EA	6	179	1074
3 X 20 PVC SCH80 PE PIPE PER	EA	6	220.2	1321.2
5 PVC SCH80 VAN STONE FLG	EA	40	26.76	1070.4
5 PVC SCH80 TEE	EA	10	50.9	509
5 PVC SCH80 SXS 90 ELL	EA	20	32.79	655.8
5 PVC SCH80 SXS 45 ELL	EA	10	38.04	380.4
3 X 6 PVC SCH80 WYE	EA	10	471.89	4718.9
3 PVC SCH80 SXSXS TEE	EA	4	277.7	1110.8
3 PVC SCH80 SXS 90 ELL	EA	2	73.98	147.96
3 X 6 PVC SCH80 SXS CPLG	EA	2	146.25	292.5
3 PVC SCH80 VAN STONE FLG	EA	7	37.4	261.8
24X8 PVC SCH80 REDUCER	EA	1	2203.2	2203.2
5 HDPE IPS WELD FLANGE	EA	10	need more info	please advise
3 HDPE IPS WELD FLANGE	EA	1	need more info	please advise
5" FLG ACCESSORY KIT	EA	20	9.65	193
3" FLG ACCESSORY KIT	EA	7	10.4	72.8
herc 60465 1QT Pvc Primer (CLEAR)	EA	12	12.44	149.28
HERC 60120 1QT PVC CL CEMENT	EA	12	13.4	160.8
3 PVC SCH80 BLIND FLANGE	EA	6	56.45	338.7
5 PVC SCH80 SXS CPLG	EA	6	26.25	157.5
3 PVC SCH80 SXS CPLG	EA	2	35.25	70.5
TOTAL:				

Water Distribution

From: BWStratton@winwaterworks.com
Sent: Friday, July 25, 2014 4:39 PM
To: Water Distribution
Subject: Re: Town of Newburgh Vent & Exhaust Piping Quotes
Attachments: DAT-WTP-RFQ-Vent Exhaust Piping Mod.ods

Importance: High

As requested... please advise on HDPE IPS WELD FLANGES. Please confirm receiving this quote.
Thank you.

Brian Stratton

Sales

Newburgh Winwater Works

653 Rt. 52

Walden, New York 12586

(P) 845-778-3312

(F) 845-778-3830

WWW.Newburghwinwater.com

-----"Water Distribution" <waterdistribution@townofnewburgh.org> wrote: -----

To: "Brian Stratton" <Bwstratton@winwaterworks.com>

From: "Water Distribution" <waterdistribution@townofnewburgh.org>

Date: 07/25/2014 03:06PM

Subject: Town of Newburgh Vent & Exhaust Piping Quotes

Good afternoon,

Attached is a list of materials that require quotes.

If you have any questions, please contact our office at 845-564-7813.

Thank you,

Mary Butler

Clerk



TOWN OF NEWBURGH

1496 ROUTE 300, NEWBURGH, NEW YORK 12550

11A



Les Cornell
Director of Buildings & Grounds

Ph: 845-564-4556
Fax: 845-566-1432

To: Deputy Supervisor Piaquadio
Town Board

From: Les Cornell, Building & Grounds Supervisor

Date: July 11, 2014

Re: Windows

Over the last few months I have been getting prices for replacing the old single pane windows at Town Hall with new energy efficient units. I have received two quotes over that period of time. Renewal by Anderson came and looked at the job but did not submit a quote even after several follow up calls. Reliable Glass did not provide us with a quote but verbally stated that type of windows they use would probably be in the 30 to 40 thousand dollar range. I did receive a price from Pella for \$17,953.75 and also a price from No Glass for \$10,875.00.

QUOTE**NU-GLASS & STOREFRONTS INC**

154 North Plank Road, Newburgh, New York 12550
 Phone (845) 562-8387 Fax (845) 565-0991
 Rack101@optonline.net

DATE: MAY 20, 2014

EXPIRES in: 60 days

Town Newburgh

SALESPERSON	JOB	PAYMENT TERMS	DUE DATE
Rick	Replacement windows		

QTY	DESCRIPTION	UNIT PRICE	LINE TOTAL
25	36" x 60" Ellison 1300 series white vinyl replacement windows with Low E/ argon filled insulated units. Inc half screens, night latches and (2) locks. Includes labor and caulking. Prevailing wage add 1500.00	375.00	9375.00
		SUBTOTAL	
		SALES TAX	Exempt
		TOTAL	10875.00

Quotation prepared by: Rick Powles

To accept this quotation, sign here and return: _____

THANK YOU FOR YOUR BUSINESS!



Ellison
WINDOWS & DOORS

*Windows
NO GLASS
Bid*

S e r i e s 1 5 0 0

Vinyl Replacement Windows

All-Welded Vinyl Replacement Windows. *What A Beautiful Way To Save Energy.*



Twin vent casement and half round with 5/8" grid.

You own a lovely home, and you want windows that match. That's why you'll want Ellison 1500.

These sleek vinyl windows feature the kind of crisp styling that complements any décor. And they're so efficient, they can cut your heating and cooling costs sharply.

Plus, thanks to their all-welded construction, they'll stay in great shape for years to come. So you'll enjoy both high style and high performance. What could be more beautiful?

We start with solid vinyl.

Why? Because vinyl is virtually maintenance free:

- Unlike wood, it won't crack or rot.
- Unlike aluminum, it won't corrode or allow excess condensation.
- It never needs repainting or refinishing.
- It wipes clean in a matter of moments.

But not all vinyl is created equal. So we use only premium virgin vinyl. And unlike most manufacturers, we extrude it ourselves, using our own special process. That way we can ensure consistent durability, window after window.

Plus, we fusion-weld our frames and sashes. We know welding adds solid structural strength, along with seamless beauty. And to enhance the beauty further, we bevel the mainframe, for a stylish "finished" look.

Ellison Series 1500.

Classic Windows That Will Warm Up Your Home.

Jamb Depth: 3.25"

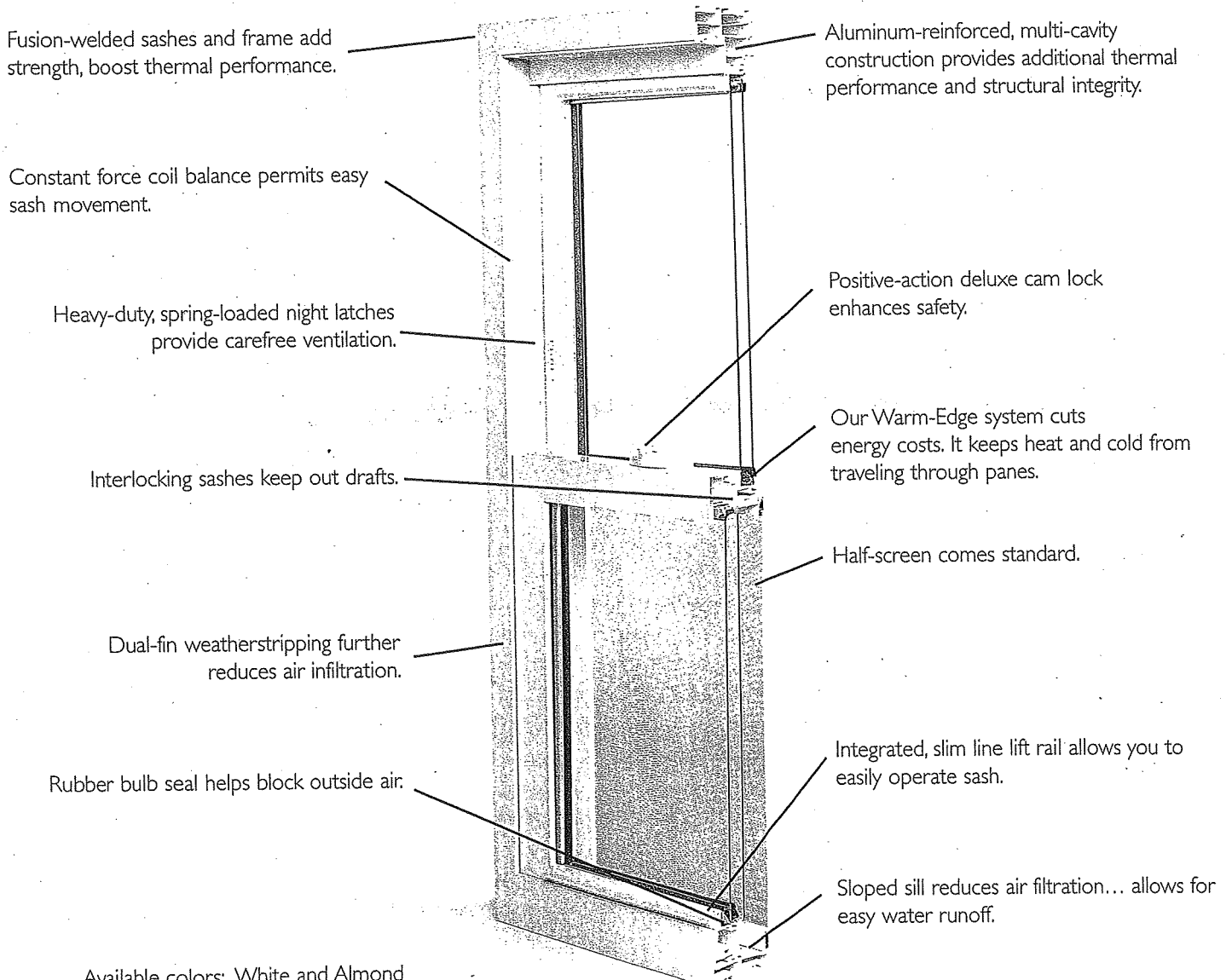

Available colors: White and Almond

Manufacturer reserves the right to substitute components as necessary.

Warm-Edge Glass Technology:

All Series 1500 Double Hung windows are simple to clean. Sashes tilt in so you can easily reach entire surface.

All Ellison windows feature our Warm-Edge insulated glass.

And the efficiency doesn't end there. Between the glass panes, the Warm-Edge glass is scientifically designed to flex with the glass in any temperature – hot or cold.

The exterior of this spacer is surrounded by a thick, insulating buffer that prevents heat and cold from traveling through the panes. Only this "warm edge" comes in contact with the glass. During cold weather, the inside glass perimeter stays warmer. During summer, the inside glass surface stays cooler. And so does your home's interior. So, year-round, you conserve energy and save substantially on fuel bills.

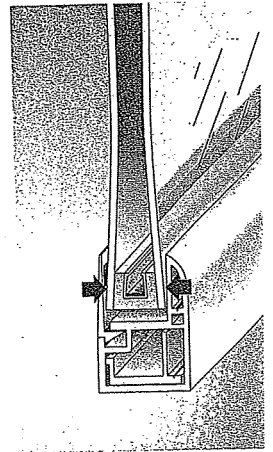

Our products
spa

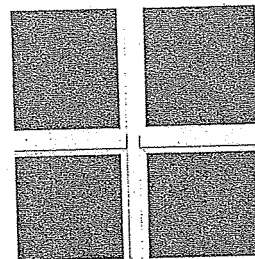

Optional grids come fixed between panes, so they'll never get in your way. (1" contoured shown here.)

Tilt-in sashes and "between the panes" grid make Ellison Double Hung windows quick and easy to clean.

The Secret To Our Inner Beauty.

Low-E glass with Insulating Argon Gas

This combination of features is built-in to every Series 1500 window we produce. Windows with Low-E glass and Argon gas dramatically improve the window's insulating performance. The glass

is made with a surface that reflects the sun's heat away from the home during hot summer months, while reflecting your home's heat back inside during cold winter months. No matter what the season, Low-E with Argon filled glass panels will save you money and make your home more comfortable.

As a seal of assurance, this glass feature makes all Series 1500 windows Energy Star compliant anywhere in the country.

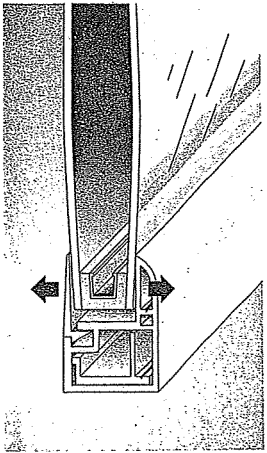

See a Warm-Edge stem

Ask about our other options:

- Obscure Glass
- Double-Strength Glass
- 5/8" Flat Grid
- 5/8" or 1" Contoured Grid
- 5/8" Diamond Grid

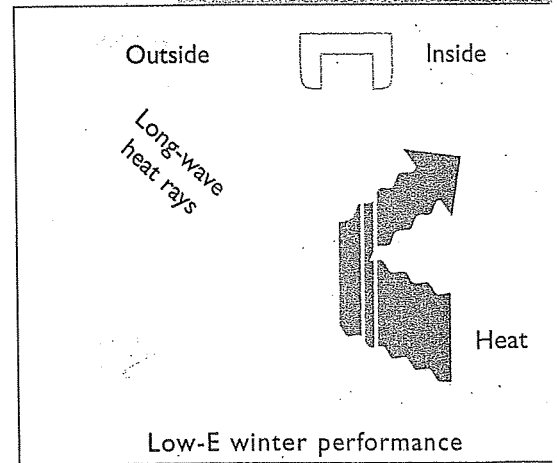

Ellison Windows and Doors is proud to promote energy-efficient products in conjunction with the Energy Star for Windows program.

The Secret To Our Inner Beauty.

Low-E glass with Insulating Argon Gas

This combination of features is built-in to every Series 1500 window we produce. Windows with Low-E glass and Argon gas dramatically improve the window's insulating performance. The glass

is made with a surface that reflects the sun's heat away from the home during hot summer months, while reflecting your home's heat back inside during cold winter months. No matter what the season, Low-E with Argon filled glass panels will save you money and make your home more comfortable.

As a seal of assurance, this glass feature makes all Series 1500 windows Energy Star compliant anywhere in the country.

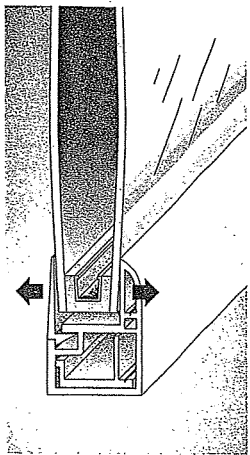

a Warm-Edge
seal

Ask about our other options:

- Obscure Glass
- Double-Strength Glass
- 5/8" Flat Grid
- 5/8" or 1" Contoured Grid
- 5/8" Diamond Grid

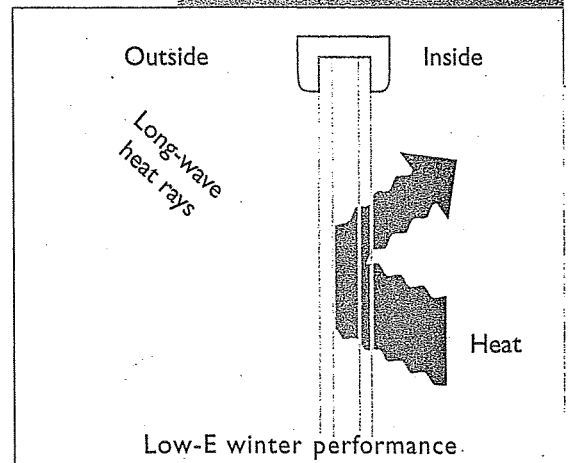

Ellison Windows and Doors is proud to promote energy-efficient products in conjunction with the Energy Star for Windows program.

Sliding Vinyl Patio Doors From Ellison: *Opening Up Even More Possibilities.*



#311 Sliding Patio Door

#311 Ellison Sliding Patio Door:

- Fully welded frame and panel come pre-assembled for easy installation.
- Reversible design lets you locate moving panel either left or right.
- Warm-Edge insulated glass resists condensation, boosts efficiency.
- Integrated nailing fin helps you install doors quickly – ideal for new construction. (Order door without fin for replacement application.)
- Sliding panel and meeting rail reinforced with roll-formed steel to ensure rigidity and strength.
- Aluminum track for movable panel means a smooth, easy glide.
- Interlocking panels prevent air infiltration.
- White enameled exterior handle and oak interior handle with built-in lock (shown here).
- Optional 5/8" flat and 1" contoured grid.
- Optional screen.
- Available in White only.
- Low-E optional.
- Available in 5', 6' and 6'4 configurations.

#312 Ellison Sliding Patio Door:

Extra beauty, security, options

- Reversible sliding panels install to open either left or right.
- Both panels come reinforced with steel for extra strength.
- Door frames come fully welded, fully assembled and complete with screen. (Most others do not.)
- Interlocking panels virtually eliminate air infiltration.
- 7/8" Warm-Edge sealant system with unique warm edge keeps heat and cold from traveling through glass surface.
- High-performance tempered glass comes insulated with thermal air or optional Argon gas.
- Easily removable nailing fin simplifies installation for replacement application.
- Standard screen fits easily on site.
- Deluxe color matched hardware comes with secure key lock.
- Available in crisp White or versatile Almond.



#312 Sliding Patio Door with Dark Hillside
Interior Wood Finish and Brass Grid.

DO NOT REMOVE

MAKE DATE: 10/6/1999 WARRANTY: 02589514
SALES ORDER: 00735962

Every Ellison 1500 window comes with a transferable, limited lifetime warranty covering vinyl, glass, and all working parts. This superb warranty comes with a Product ID Number for easy ordering of replacement parts. If you ever need to order parts within the warranty period, just find the ID sticker on the window and mention the Product ID Number when you call.

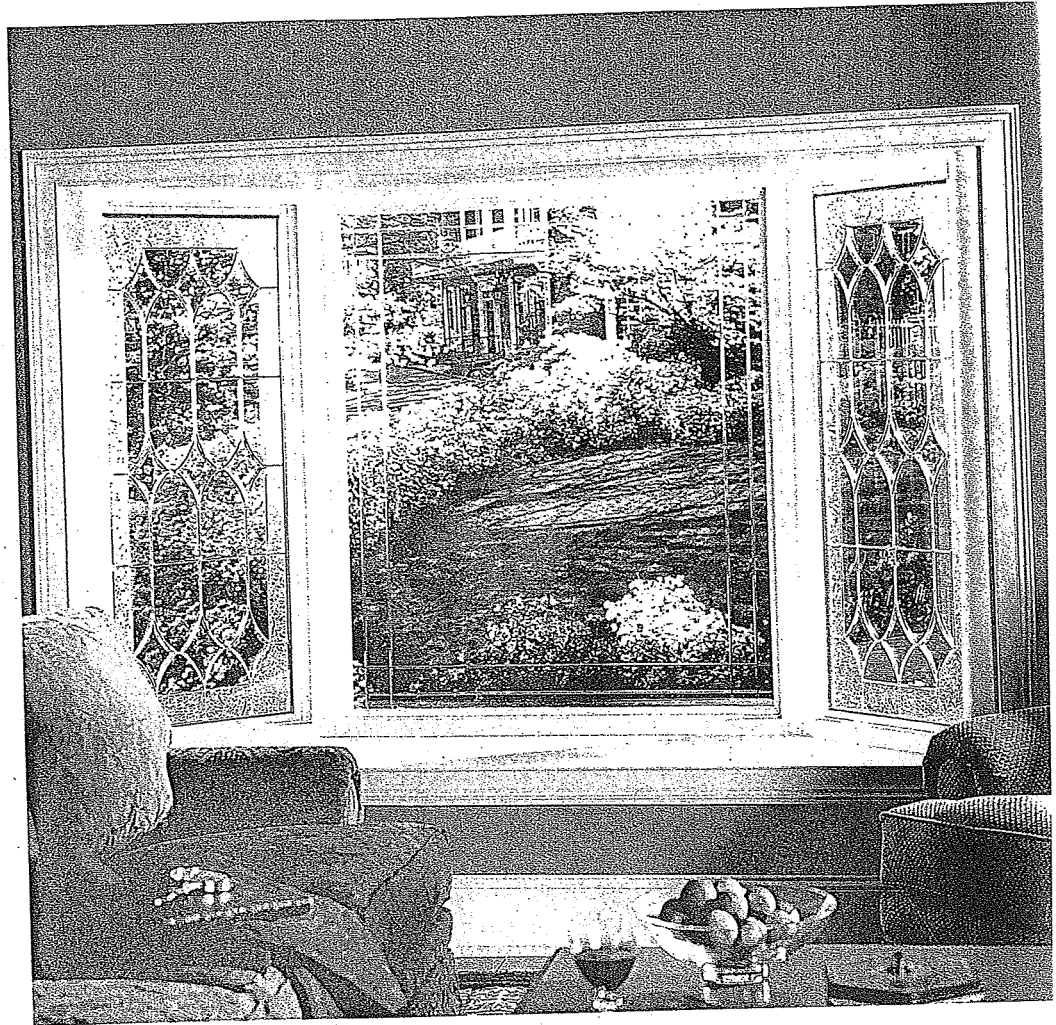

Bay window featuring Leaded glass and Double Prairie grid in a fixed lite casement unit.

A sampling of available styles and specialty shapes

Double Hung Windows

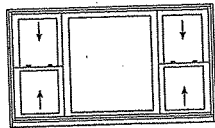

#1500 PW Picture Window
with #1500 DH Double Hung Flankers

Bow Windows

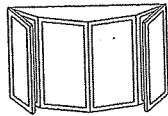

#1500 4L 4-Lite Bow

Specialty Shapes



#1500 OC Octagon

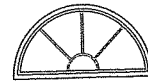

#1500 HR Half Round
Sunburst Grid

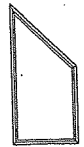

#1500 SS Trapezoid

Kids Can't Fly

Screens are not designed to restrain a child from falling through an open window. Please take proper precautions.

Distributed By:

Ellison
WINDOWS & DOORS

www.ellisonwindow.com



Contract - Detailed

Pella Window and Door Showroom of Paramus
483 Route 17 South
Paramus, NJ 07652-3001
Phone: 2012251385 Fax: 2012251388

Sales Rep Name: Rouse, Jason
Sales Rep Phone: 973-575-0200
Sales Rep Fax:
Sales Rep E-Mail: jrouse@njpella.com

Customer Information	Project/Delivery Address	Order Information
Town Of Newburgh Town Hall 1496 Route 300 NEWBURGH, NY 12550-2697 Primary Phone: (845) 5644552 Mobile Phone: Fax Number: E-Mail: Great Plains #: Customer Number: 1006899552 Customer Account: 1002357531	Town Hall, Town Of Newburgh, 1496 Route 300, Newburgh 1496 Route 300 Lot # Newburgh, NY 12550-2697 County: Orange	Quote Name: Town Hall, Town Of Newburgh, 1496 Route Order Number: 751 Quote Number: 5785952 Order Type: Installed Sales Payment Terms: Tax Code: OR-CAP Quoted Date: 6/10/2014

Line #	Location	Attributes	Qty
10	None Assigned	Vinyl Windows / Doors By Pella, Replacement Double Hung, White	24

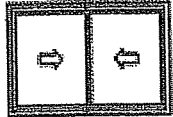

PK #
641

1: Double Hung, Equal
General Information: Standard, Vinyl, Block Frame With Mull Groove, 3 1/4", 3 1/4", Sill Adapter Included, No Head Expander
Exterior Color / Finish: White
Interior Color / Finish: White
Glass: Insulated Low-E Advanced Low-E Insulating Glass Argon Non High Altitude
Hardware Options: White
Screen: Full Screen
Grille: No Grille.

Viewed From Exterior

Customer: Town Of Newburgh Town Hall

Project Name: Town Hall, Town Of Newburgh, 1496 Route
300, Newburgh

Order Number: 751

Quote Number: 5785952

Project Checklist has been reviewed

Customer Name _____ (Please print)

Pella Sales Rep Name _____ (Please print)

Customer Signature _____

Pella Sales Rep Signature _____

Date _____

Date _____

Credit Card Approval Signature _____

Order Totals	
Taxable Subtotal	\$17,953.75
Sales Tax @ 0%	\$0.00
Non-taxable Subtotal	\$0.00
Total	\$17,953.75
Deposit Received	
Amount Due	\$17,953.75

For more information regarding the finishing, maintenance, service and warranty of all Pella® products, visit the Pella® website at www.pella.com

Contract Notified



MENU

Pella® 250 Series Single-Hung Window ▾

Pella® 250 Series Single-Hung Window

- [Architect Series® Single-Hung Window](#)
- [Pella® Impervia® Single-Hung Window](#)
- [Encompass by Pella® Single-Hung Window](#)
- [Pella® 350 Series Single-Hung Window](#)
- [Pella® 250 Series Single-Hung Window](#)

[Explore Window Styles](#) > [Single-Hung Windows](#)

Pella® 250 Series Single-Hung Window



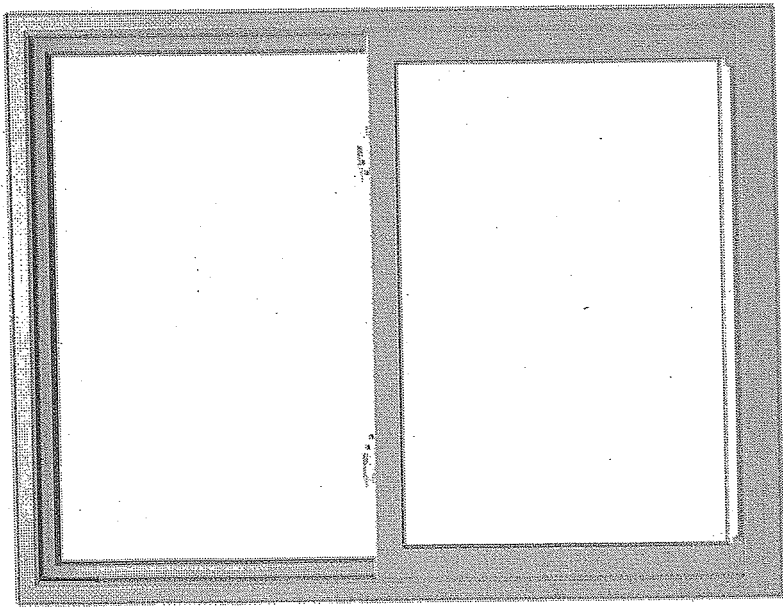

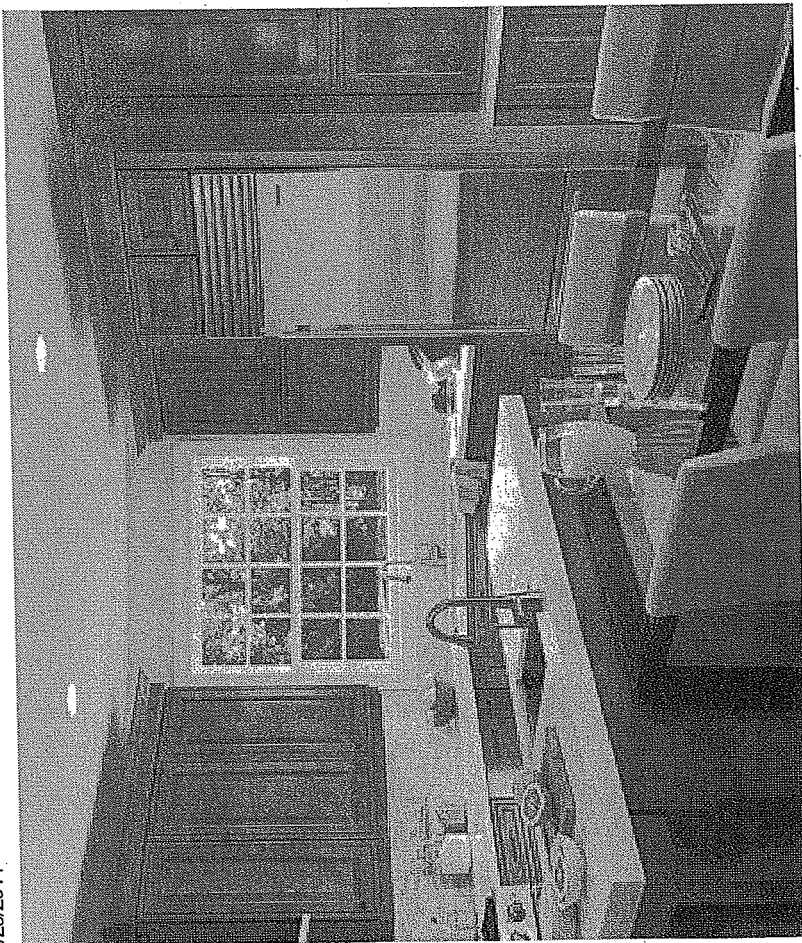

Please hover over the large image above for more details.

Features

- Frame that's 52% stronger than ordinary vinyl¹
- 54% — 77% more energy-efficient with triple-pane glass²
- More of our most popular features and design choices
- Easy-wash feature, tilt-in sash feature.

[VIEW ALL WINDOW OPTIONS >](#)

[DESIGN YOUR WINDOW >>](#)

Where to Buy

YOUR ZIP CODE

Please enter a valid zip code.

- Get a Free Quote

See it at a store near you »

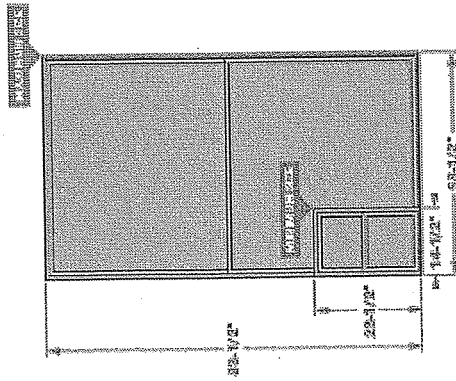

Sizes

Replacing, remodeling or building a new home? Pella offers a variety of sizes to fit most any project. Choose from a wide range of standard sizes or we can build products to fit your specifications.

Built to order in 1/8" increments for a precise fit.

- [View Pella 250 Series Single-Hung Window Size Chart »](#)
- [View East/West map](#)

Need help figuring out the size you need?
[Contact Pella »](#)

Brochure

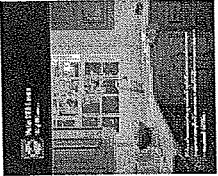

- [View Digital Brochure »](#)
- [View East/West map](#)

Pricing

The cost of each window or door can vary significantly based on many factors, such as your choice of size, frame material, glass type, finish options, etc.

- [Learn about costs »](#)

Warranty

Pella products are backed by some of the best warranties in the business.

- [Vinyl Window and Patio Door Limited Warranty \(PDF\) »](#)
- [Ventana de Vinilo y Puerta para Patio Pella »](#)

Installation

The best-performing windows and doors are only as good as their installation.

- [Installation by a Pella Expert »](#)
- [Locate a qualified contractor »](#)
- [Install them yourself »](#)

Energy Performance



Pella products offer the energy-efficient options that will meet or exceed ENERGY STAR® guidelines in all 50 states.¹



Pella's InsulShield® energy-saving technology can make a major difference in your home's comfort and energy use.

- [View NFRC Energy Ratings for All Glass Types »](#)

Pella Product Designer

You can design and visualize this window right now on your computer screen.

Pella® 250 Series Single-Hung Window Options

Interior/Exterior Frame

Pella® 250 Series windows have easy-care vinyl frames in your choice of two colors. [More Details »](#)

White

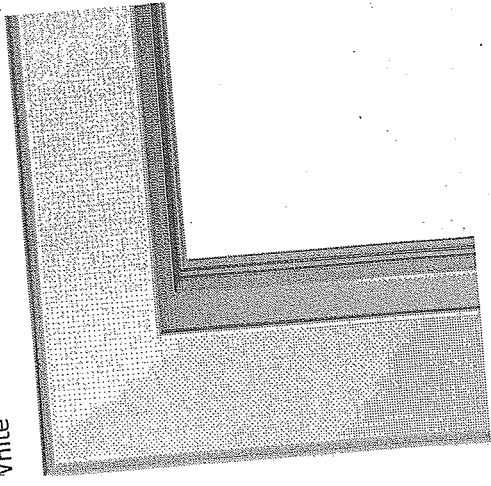

Almond

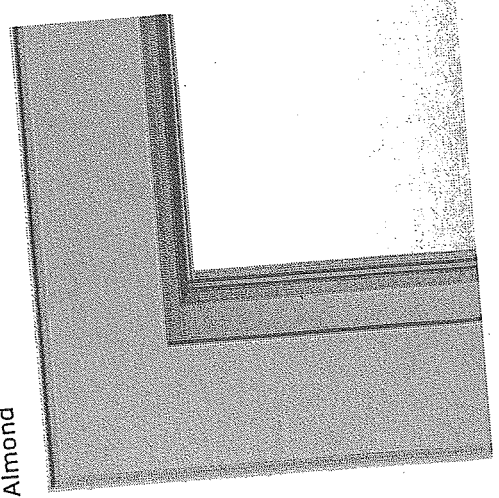

Grille Patterns

Grilles give the appearance of individual window panes. Pella offers many grille patterns to help enhance your home's architectural style.

Prairie

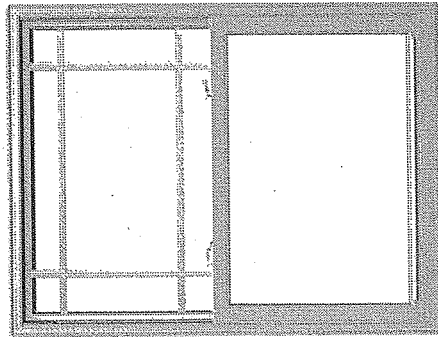

Custom (equally divided)

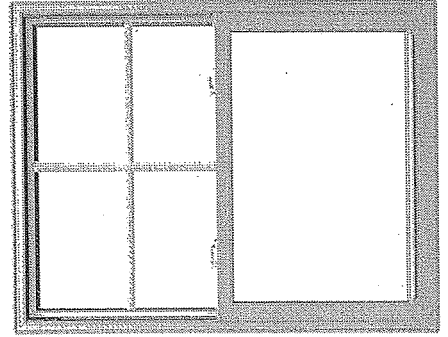

7/29/2014

Traditional

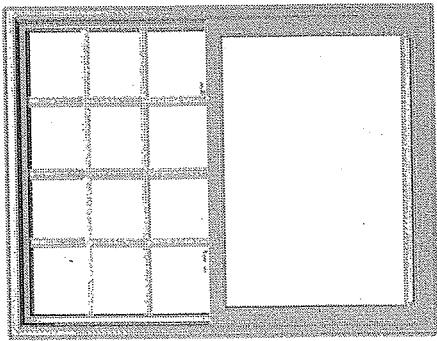

Top Row

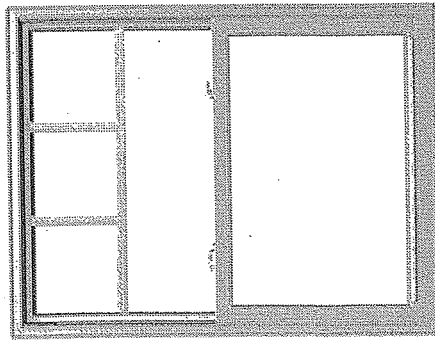

6-Lite Prairie

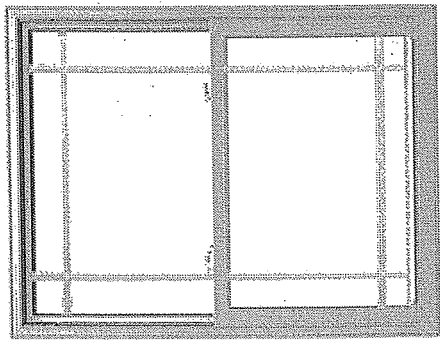

None

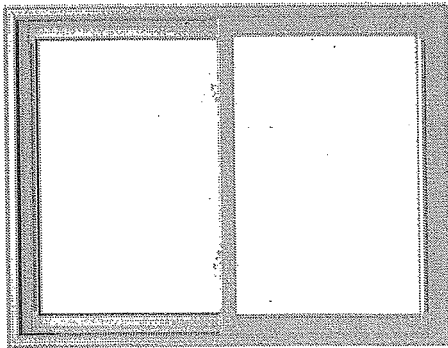

Grille Profiles

For the classic look of individual windowpanes, choose Grilles-Between-the-Glass, or Simulated-Divided-Light Grilles [More Details »](#)

5/8" Flat grilles-between-the-glass

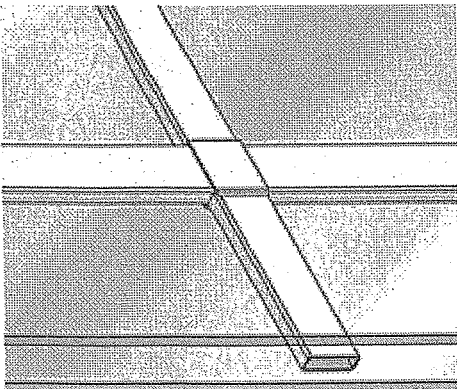

3/4" Contour grilles-between-the-glass

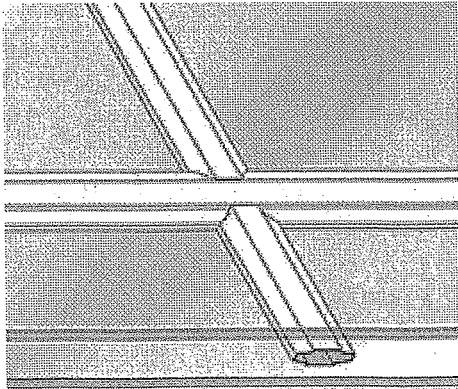

1" Contour grilles-between-the-glass

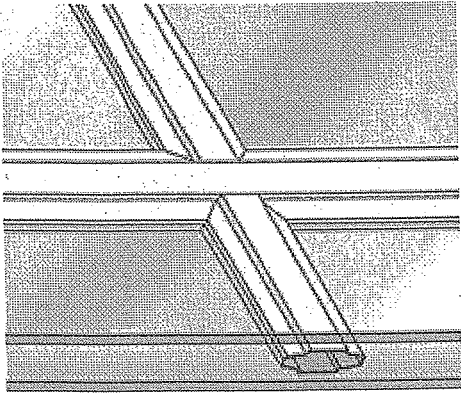

7/8" Simulated-Divided-Light Grilles

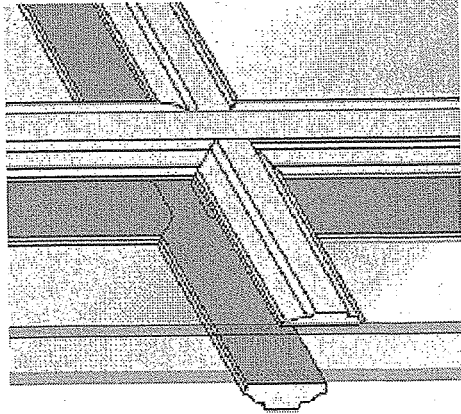

Grilles - Between-the-Glass

Grilles are permanently sealed between the panes of insulating glass.

-
-
-

Simulated-Divided-Light Grilles

Permanently bonded to the inside and outside of your window glass. There is no spacer between the grilles.

Hardware

Pella's cam-action lock and AutoLock hardware styles are available in your matched color finishes.

Cam-Action Lock White

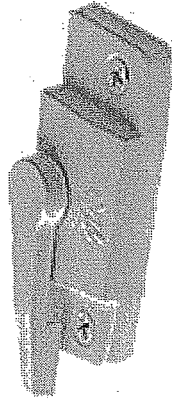

Cam-Action Lock Almond

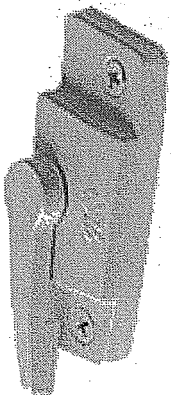

AutoLock White

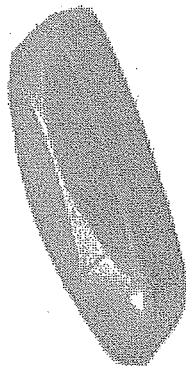

AutoLock Almond

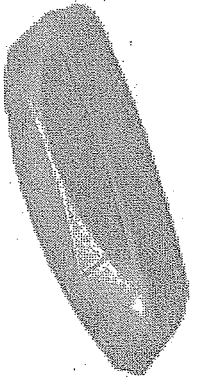

Style

•

•

Finish

•

•

•

•

7/29/2014

Screens²

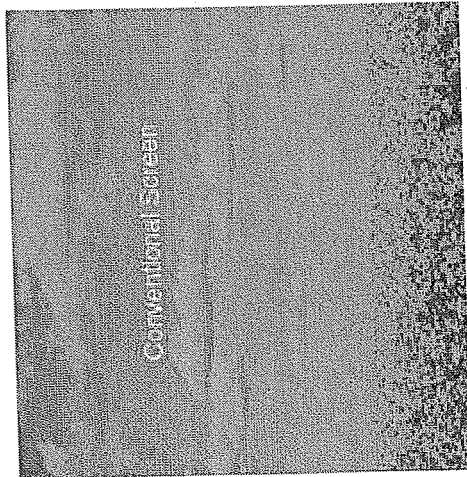

Conventional Fiberglass Screens

Window and door screens play an important role in your home's light, ventilation and view. Our conventional fiberglass screens allow in light and the breeze and are durable to stay looking great for years.

Glass Options

Insulshield Glass Collection⁶

Pella's InsulShield[®] glass collection offers our most innovative and energy-saving choices for your climate. [More Details »](#)

Advanced Low-E Insulating Glass with Argon⁷



Best Use:
Most Climates

SunDefense Low-E Insulating Glass with Argon⁷



Best Use:
Hot, sunny climates

NaturalSun Low-E Insulating Glass

<http://www.pella.com/windows/explore-window-styles/window.aspx?type=pella-250-series-single-hung-window>

- [CA SUPPLY CHAIN ACT](#)
- [PRIVACY POLICY](#)
- [SITEMAP](#)

© 2014 PELLA CORPORATION, ALL RIGHTS RESERVED.



VIEWED TO BE THE BEST.



113

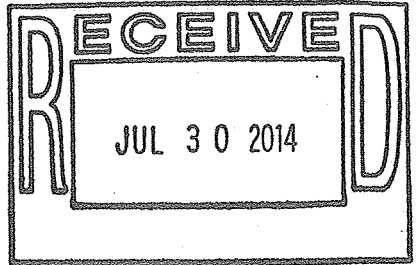

TOWN OF NEWBURGH
TOWN ENGINEER
1496 Rte. 300
Newburgh, NY 12550
(845) 564-7814

MEMORANDUM

TO: Gil Piaquadio, Deputy Supervisor & Town Board
FROM: James W. Osborne, Town Engineer *JWO*
DATE: July 29, 2014
RE: M \ TOWN HALL – OLD TOWN HALL
STANDBY GENERATOR

I am requesting Town Board approval for the following proposed bid schedule:

- Advertise for Bids: August 6, 2014 (MHT)*
August 8, 2014 (Sentinel)
- Open Bids: September 5, 2014
- Award Contract: September 15, 2014
- Contract Signing / Pre-Con. Mtg.: September 25, 2014
- Project Completion: December 15, 2014

* **Requires that the Notice to Bidders be delivered to MHT by Friday, 1 August 2014.**

As the above requires Town Board action, I am requesting that this item be placed on the 4 August 2014 agenda for approval. If you have any questions or comments, I am available to discuss them with you.

JWO/id
cc: A. Zarutskie, Town Clerk
M. Taylor, Attorney
L. Cornell, B & G
R. Clum, Accountant

Powder Mill Road Stone Wall over Bridge

On November 7, 2013 a vehicle struck the north side of the stone wall over the bridge on Powder Mill Road. This vehicle was insured by Travelers Insurance Company.

The town submitted a claim to travelers because the stone wall is within the town's right of way

An estimate was received to rebuild the stone wall for \$ 19,900.00

Based on depreciation the insurance company will give us \$ 5,188.46

After consulting our Highway Superintendent I am suggesting we square off the broken end of the stone wall and install 48 feet of tubular guard rail as shows on attached photo

A handwritten signature in black ink, appearing to be 'J. Ed' or similar, located in the lower right quadrant of the page.



60 Lakefront Boulevard
Buffalo, New York 14202

12
Melinda Friel
Claim Representative
716-855-5631
mfriel@travelers.com

May 15, 2014

Town of Newburgh
311 Route 32
Newburgh, NY 12550

CC: Atty: Mark C. Taylor

Insured: Jeffrey McCormick
Claimant: Town of Newburgh
Date of incident: 11/07/2013
Claim #: HTJ8692

Dear Mr. Piaquadio:

We have completed our investigation and appraisal of your property damage claim.

As we previously discussed, Travelers policies pay Actual Cash Value (ACV) for property damage. Based on our property appraisal we have found the Replacement Value of the damages to the retaining wall to be \$19,955.60. After further investigation, it was discovered that the life expectancy for a mason stone wall would be 100 years and would depreciate at a rate of 1% per year of age. Since the wall was constructed in 1940, 74% depreciation would apply. Depreciation of 74% amounts to a total of \$14,767.14. Therefore, we are offering you \$5,188.46 for your damages.

Please contact me to discuss this decision further. I can be reached at (800) 662-2310 x5631.

Sincerely,

Melinda Friel
CC: File

L. S. L. W. Corp.

dba Lynn Warren Landscaping
 18 north fostertown drive
 Newburgh, NY 12550
 (845) 564-8760

Estimate

Date	Estimate #
1/15/2014	137

Name / Address
TOWN OF NEWBURGH,BUILDING & GROUNDS 1496 ROUTE 300 Newburgh, NY 12550

			Project
Description	Qty	Cost	Total
WALL AND PILLAR REPAIR TO BRIDGE ON POWDER MILL ROAD TO ORIGINAL CONDITION.			
12 X 6.5 X2 WITH CAPS			
4 PILLARS 2X2X4.5			
RE-USING THE ORIGINAL STONE WHEN POSSIBLE FOR THE SUM OF			
LABOR	1	15,200.00	15,200.00T
MATERIAL	1	4,700.00	4,700.00T
		Subtotal	\$19,900.00
		Sales Tax (0.00)	\$0.00
		Total	\$19,900.00

Agreed and Accepted: _____

This proposal may be withdrawn by us if not accepted within 15 days. All material is guaranteed to be as specified. All work to be completed in a workmanlike manner according to standard practices. Any alteration or deviation from the above specifications involving extra costs will be executed only upon written orders, and will become an extra charge over and above the estimate. All agreements contingent upon strikes, accidents or delays beyond our control. Owner to carry fire, tornado and other necessary insurance. Our workers are fully covered by Workmen's Compensation Insurance.

Powder Mill Rd
50 074

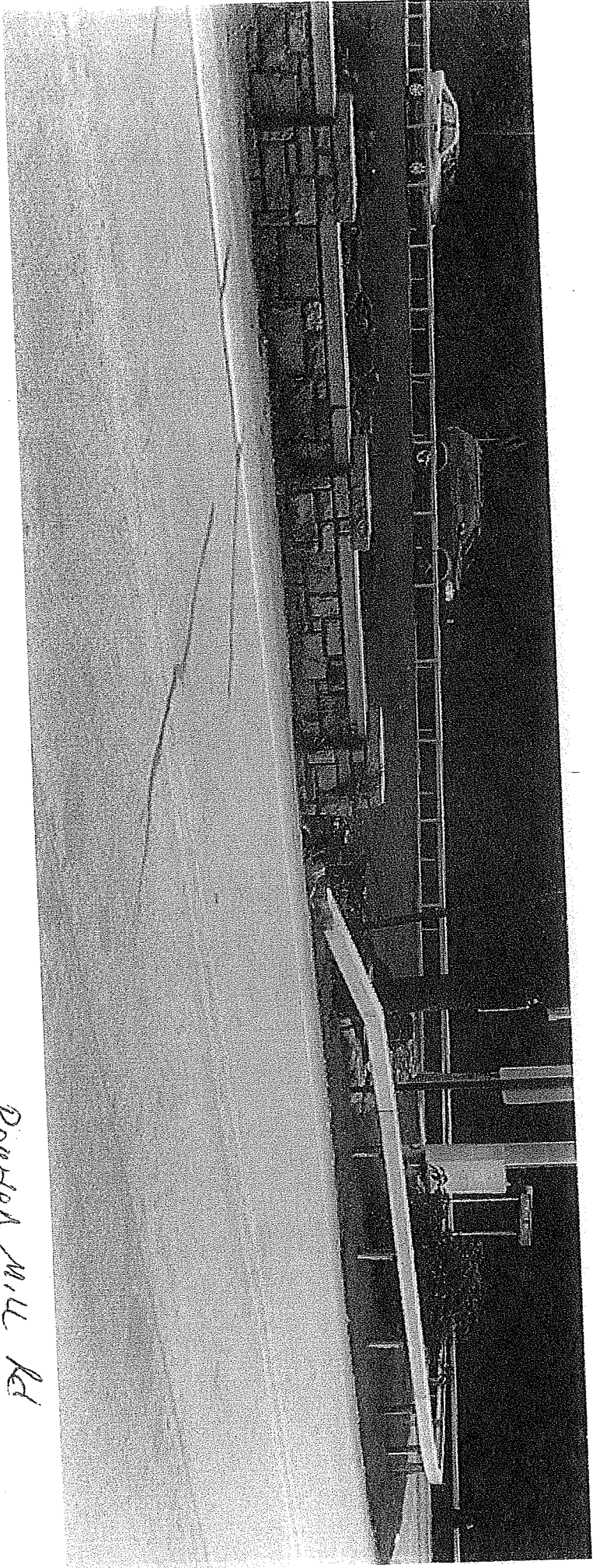

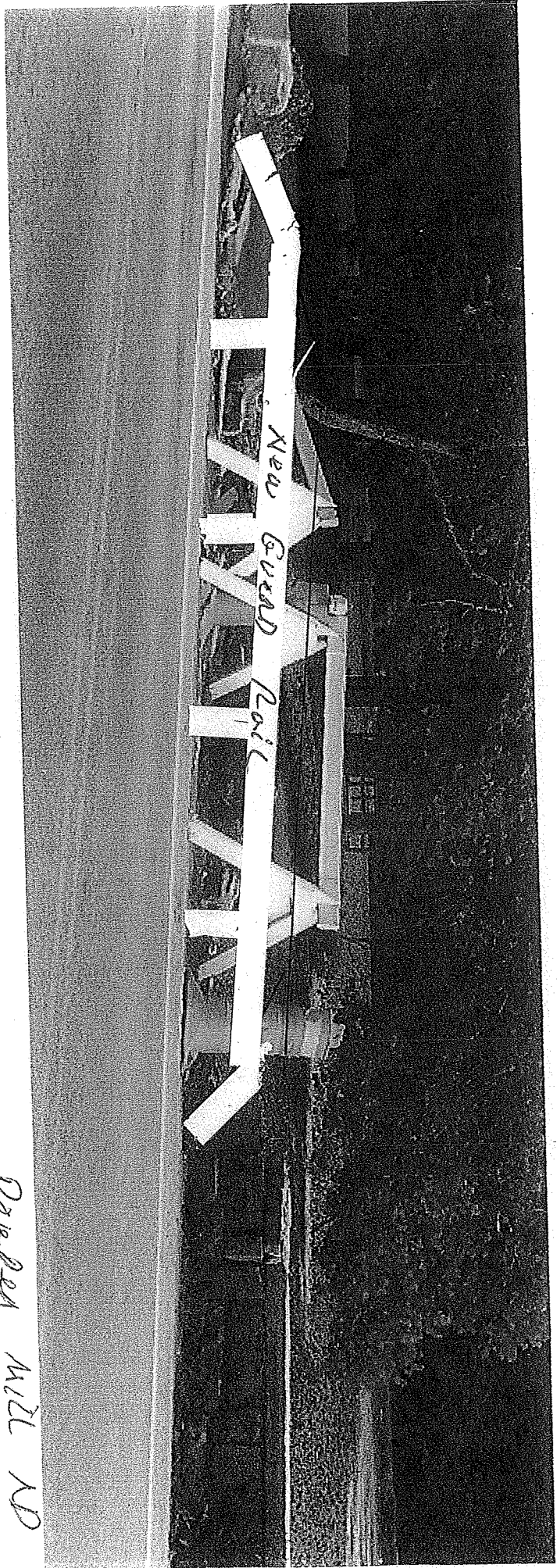

PAVING WILL BE
NEXT

SALESMAN

105

SUGGESTED VENDOR

DATE

9-29-14

SHIP TO:

T. Newland
90 SHAWNEEK RD.
NEWBURGH, N.Y. 12550

BILL TO:

TRACOTR TRAILER ACCESSIBLE: Y N

COUNTY

Orange

RECEIVING TIME: 7-3 m-f

GATE IN YARD: Y N

CONTACT:

Todd DeFels

PHONE:

845-561-2111

CUSTOMER P.O.#

N/A

MATERIAL:

Rubber Mill Rd. - Tomb Rd.

QTY	MATERIAL	COST	WEIGHT	S/P	EXTENSION
48'	Box Beam 241. (2-24')			49.80	2,265.60
2	Box Beam Type T GWS complete			624.00	1,248.00
9	3" X 5'3" posts for Box Beam			40.40	363.60
2	Pair splice plates w/braces			Incl.	Incl.
1	Pair 1/2" best splice plates w/braces			Incl.	Incl.
9	STEEL BRACES w/ 3/8" x 2" + 1/2" top plate			138.40	1,245.60
48'	INSULATION				
					4,721.52

SPECIAL INSTRUCTIONS:

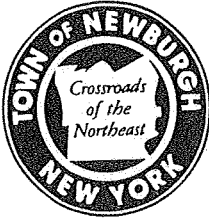

TOWN OF NEWBURGH

1496 Route 300, Newburgh, New York 12550

13A

Brenda

PERSONNEL DEPT.

PH: 845-566-7785
Fax: 845-564-2170

To: Gilbert Piaquadio, Deputy Supervisor
Town Board

From: Charlene M Black, Personnel

Date: July 29, 2014

Re: Justice Court: Clerk to the Justice

Town Justice Jude martini has interviewed for the full time position that is now available in his department due to the retirement of Frances Bockemuhl. He would like to offer the position to Dessy Acevedo.

All paperwork is attached: application, employment request form and letter from Mr. Martini. Ms Acevedo's employment is pending the Town Board's approval, paperwork to be completed, physical, Drug/alcohol testing and finger printing. The rate of pay is 18.64 per hour and with favorable results, start date can be on or after August 7, 2014 depending on how quickly I can get her in for the required paperwork, etc..

Thank you in advance.

TOWN OF NEWBURGH
EMPLOYMENT REQUEST FORM

TO: PERSONNEL DEPARTMENT

NAME OF CANDIDATE: Dessy Acevedo

DEPARTMENT: Justice Court

TITLE OF POSITION: Clerk to Town Justice

FULL TIME OR PART TIME: Full Time

HOURLY RATE: \$18.64

IS POSITION FUNDED IN CURRENT BUDGET: yes or no

FUND APPROPRIATION NUMBER: 1110-0100

PROPOSED HIRE DATE: On or about August 7, 2014

NOTE: CANDIDATE CANNOT BEGIN WORK WITHOUT PRE-EMPLOYMENT PHYSICAL AND COMPLETION OF ALL REQUIRED PAPERWORK.

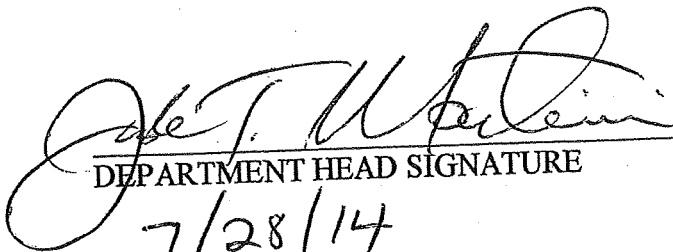
DEPARTMENT HEAD SIGNATURE

7/28/14
DATE

ORIGINAL APPLICATION MUST BE ATTACHED TO THIS FORM.
COPY TO ACCOUNTING DEPARTMENT
(02/04)



NEWBURGH TOWN COURT
311 ROUTE 32
NEWBURGH, NEW YORK 12550

TELEPHONE (845) 564-7165
FACSIMILE (845) 564-7171

HON. JUDE T. MARTINI
TOWN JUSTICE

FRANCES BOCKEMUHL
COURT CLERK TO TOWN JUSTICE

July 28, 2014

Gilbert J. Piaquadio, Deputy Supervisor/Acting as Supervisor
Town of Newburgh
Town Hall
1496 Route 300
Newburgh, NY 12550

RE: Fill Vacancy for Court Clerk

Dear Supervisor:

As you already know, my clerk Frances Bockemuhl is retiring effective July 31, 2014. I would like to fill this position as soon as possible and appoint the following candidate as her replacement:

Dessy Acevedo
77 Commonwealth Avenue
Middletown, New York 10940
917-622-2086

I am requesting this matter be placed on the next available agenda for approval by the Town Board.

Thank you.

Very truly yours,

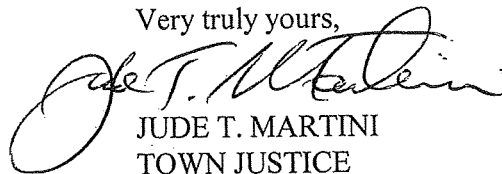

JUDE T. MARTINI
TOWN JUSTICE

cc: Members of the Town Board
Andrew Zarutskie, Town Clerk
Charlene Black, Personnel

BB



TOWN OF NEWBURGH JUSTICE COURT
311 ROUTE 32
NEWBURGH, NEW YORK 12550

TELEPHONE (845) 564-7161
FACSIMILE (845) 564-7171

HON. RICHARD CLARINO
TOWN JUSTICE

DEBRA A. MOORE
COURT CLERK TO TOWN JUSTICE

August 1, 2014

Hon. Gilbert Piaquadio
Supervisor, Town of Newburgh
1496 Route 300
Newburgh, New York 12550

Re: Staff Vacancy

Dear Mr. Piaquadio:

As you know, court clerk Kelly Pugh's employment ended on July 31, 2014.

I respectfully request that you immediately cause a canvass to be made so that we can fill the civil service position left vacant by Ms. Pugh's departure.

Please feel free to contact me if you have any questions or need to discuss this further.

Very truly yours,

RICHARD CLARINO
Town Justice, Town of Newburgh

cc: Charlene Black, Director of Personnel

14A

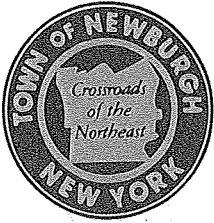

TOWN OF NEWBURGH RECREATION DEPARTMENT

311 ROUTE 32, NEWBURGH, NY 12550

Robert J. Petrillo
Commissioner of Parks, Recreation & Conservation

845-564-7815
FAX: 845-564-7827

July 28, 2014

TO: Gil Piaquadio, Acting Supervisor
Town Board Members

FROM: Robert J. Petrillo, Commissioner

RE: Payment Authorization Request

At this time we are requesting payment from the T-38 account for DMU Music in the amount of \$450.00 for the PA System and DJ services at Community Day on Friday, July 18th.

Thank you for your consideration.

Regards,

A handwritten signature in black ink, appearing to be "R. J. Petrillo", is written above the printed name.

R. J. Petrillo
Commissioner

14 B

Cronomer Valley Fire Department

336 North Plank Road

Newburgh, NY 12550

(845) 564-2020 / (845) 564-4611

July 2, 2014

Town of Newburgh Town Board
1496 Route 300
Newburgh, NY 12550

Dear Supervisor Piquadio,

I am proud to formally announce that the Cronomer Valley Fire Department will be hosting the 99th Annual Orange County Volunteer Firemen's Association Convention and Parade the week of September 21 – 27, 2014.

After many months of discussion and planning, we would like to formally request permission from the Town of Newburgh Town Board to use the Chadwick Lake Park and Public Service Building Parking Area on Saturday, September 27, 2014, for the Judging Portion of Fire Equipment and the finish of the Parade. The Park would be in use by the Fire Departments, County Association and public from 8:00 am until 9:30 pm.

For further information, the Parade Line-up (12:30 pm) would be located in the Hy Vue and Brewer Road (West Wedgewood) Housing Developments. The Parade will commence at 2 pm from the Line-up area and proceed west on North Plank Road to Paffendorf Drive, returning to North Plank Road, (past the Reviewing Stand at the Cronomer Valley Fire House), traveling through the Holt's Corners (Rt. 32 + 300) Intersection and ending at the Chadwick Lake Park.

The Cronomer Valley Fire Department and Orange County Volunteer Firemen's Association would also request permission to serve beer after the parade in the monitored, enclosed skating area. The Fire Department and County Association will provide the Town of Newburgh with a secondary insurance policy to cover the event and the town's properties.

Our Fire Department's final request is for permission to possibly hold a Fireworks Display at the Closing Ceremony after the Parade on September 27, 2014.

Cronomer Valley will also provide the Town of Newburgh with copies of any and all additional paperwork that will be required to hold such an event.

I want to thank you for your consideration. If you have any questions, please contact the Parade Committee at any time. We look forward to hosting this special County-wide event and working with the Town of Newburgh Town Board, Town Departments, Community Organizations and Local Businesses to make this a huge success!

Sincerely,

A handwritten signature in cursive script that reads "D. Donald Greene / mfg".

D. Donald Greene, Parade Committee Member
Cronomer Valley Fire Department



13

TOWN OF NEWBURGH ANIMAL CONTROL & SHELTER
645 Gidney Ave. Newburgh, NY 12550

To: Town Board
From: Chantel Haight, Animal Control Supervisor
Date: July 29, 2014
Subject: Authorization to Pay Veterinarian Services Utilizing T-94 Account

I am requesting authorization to use the T-94 account to pay for veterinary services from Newburgh Veterinary Hospital in May and June totaling \$1835.60.

Attached please find the bills.

Thank you.

Cc: Accounting

TOWN OF NEWBURGH

1496 Route 300
Newburgh, New York 12550
(845) 564-4552

DO NOT WRITE IN THIS BOX

DEPARTMENT _____

CLAIMANT'S
NAME
AND
ADDRESS

NEWBURGH VETERINARY HOSPITAL
1716 Route 300
Newburgh, NY 12550
Tel: (845) 564-2660
www.newburghvet.com

Date Voucher Received		VOUCHER NO.
FUND - APPROPRIATION	AMOUNT	
Total		
Abstract #		

TERMS _____

Net 30 Days

Invoice # _____

Feline

Dates	Quantity	Description of Materials or Services	Unit Price	Amount
5/28/14	575341			61.25
5/29/14	575456			25.00
6/1/14	576021			148.45
6/6/14	576030			97.98
6/11/14	576376			386.05
6/12/14	576449			160.32
6/13/14	576597			60.80
			TOTAL	939.85

CLAIMANT'S CERTIFICATION

I, Dora M Coet certify that the above account in the amount of \$ 939.85 is true and correct; that the items, services and disbursements charged were rendered to or for the municipality on the dates stated; that no part has been paid or satisfied; that taxes, from which the municipality is exempt, are not included; and that the amount claimed is actually due.

7/1/14
DATE

Dora M Coet
SIGNATURE

Bookkeeper
TITLE

(Space below for municipal use)

DEPARTMENT APPROVAL

The above services or materials were rendered or furnished to the municipality on the dates stated and the charges are correct.

Date

Authorized Official

APPROVAL FOR PAYMENT

This claim is approved and ordered for paid from the appropriations indicated above

Date

Auditing Board

INVOICE

Newburgh Veterinary Hospital

1716 Route 300
Newburgh, NY 12550
845 564-2660

"Your pet is part of our family too." Visit us at www.newburghvet.com

FOR: Town of Newburgh - Feline
645 Gidney Ave.
Newburgh, NY 12550
(845) 561-3344

Printed: 07-01-14 at 1:26p
Date: 05-29-14
Account: 4417
Invoice: 575456

Date	For	Qty	Description	Price	Discount	Net Price
05-29-14	Cinco De Mayo K	2	Feline Rhino/Panleuk/Calici #1 Your cat has received the first in a series of immunizations to protect him/her against feline distemper, rhinotracheitis, and calicivirus. It is important to return for a followup booster in 3-4 weeks. Occasionally listlessness, lethargy, or localized discomfort may occur. If there is severe listlessness or facial swelling, please call us for advice.	50.00	25.00	25.00 **✓
05-29-14		2	Recommend Fecal (please dropoff) Annual fecal microscopic exams are very important for the health of your pet and, since some worms are transmissible to humans, for the health of your family. Please bring us your pet's fecal sample at your earliest convenience			0.00
05-29-14		2	Zoonoses Discussed Zoonotic potential of intestinal parasites- in particular roundworms.			0.00
Total charges, this invoice...						25.00
**Total discount included: 25.00						

Your invoice total reflects our **13 Stray Cat Accounts** discount.

LIKE US ON FACEBOOK.COM!

GOING AWAY?....BOOK YOUR PETS BOARDING RESERVATION TODAY!

In compliance with New York State law, all medications are non-refundable. We regret any inconveniences.

INVOICE

Newburgh Veterinary Hospital

1716 Route 300
Newburgh, NY 12550
845 564-2660

"Your pet is part of our family too." Visit us at www.newburghvet.com

FOR: Town of Newburgh - Feline
645 Gidney Ave.
Newburgh, NY 12550
(845) 561-3344

Printed: 07-01-14 at 1:25p
Date: 05-28-14
Account: 4417
Invoice: 575341

Date	For	Qty	Description	Price	Discount	Net Price	
05-24-14	Fred 44K-14	1	FelV/FIV ELISA in hosp	73.00	36.50	36.50	** ✓
05-24-14		1	FIV Elisa Negative			0.00	
05-24-14		1	Feline Leukemia Elisa Negative			0.00	
05-24-14		1	CONSULT / EXAM - Biannual Wel	49.50	24.75	24.75	** ✓
05-24-14		1	Pet Insurance Review			0.00	

Please visit www.petinsurancereview.com and dogtime.com for an independent review of all national pet health insurance plans

Total charges, this invoice... 61.25
**Total discount included: 61.25

Your invoice total reflects our **13Stray Cat Accounts** discount.

LIKE US ON FACEBOOK.COM!

GOING AWAY?...BOOK YOUR PETS BOARDING RESERVATION TODAY!

In compliance with New York State law, all medications are non-refundable. We regret any inconveniences.

06-05-14	2 Zoonoses			0.00
	Discussed Zoonotic potential of intestinal parasites- in particular roundworms.			
06-05-14	1 Revolution Pup/Kitten 1-5lb single	17.50	8.75	8.75 **
				<hr/>
			Total charges, this invoice...	148.45
			**Total discount included:	148.45

✓ 1/22/14

Your invoice total reflects our **13Stray Cat Accounts** discount.

LIKE US ON FACEBOOK.COM!

GOING AWAY?....BOOK YOUR PETS BOARDING RESERVATION TODAY!

In compliance with New York State law, all medications are non-refundable. We regret any inconveniences.

INVOICE

Newburgh Veterinary Hospital

1716 Route 300
Newburgh, NY 12550
845 564-2660

"Your pet is part of our family too." Visit us at www.newburghvet.com

FOR: Town of Newburgh - Feline
645 Gidney Ave.
Newburgh, NY 12550
(845) 561-3344

Printed: 07-01-14 at 1:26p
Date: 06-06-14
Account: 4417
Invoice: 576021

Date	For	Qty	Description	Price	Discount	Net Price
06-06-14	Fred 44K-14	1	Strongid deworming(roundworms,t	17.40	8.70	8.70 ** ✓
06-06-14		1	Zoonoses			0.00
			Discussed Zoonotic potential of intestinal parasites- in particular roundworms.			
06-06-14		1	Feline Rhino/Panleuk/Calici #1	25.00	12.50	12.50 ** ✓
			Your cat has received the first in a series of immunizations to protect him/her against feline distemper, rhinotracheitis, and calicivirus. It is important to return for a followup booster in 3-4 weeks. Occasionally listlessness, lethargy, or localized discomfort may occur. If there is severe listlessness or facial swelling, please call us for advice.			
06-06-14		1	RecommendFecal (please dropoff			0.00
			Annual fecal microscopic exams are very important for the health of your pet and, since some worms are transmissible to humans, for the health of your family. Please bring us your pet's fecal sample at your earliest convenience			
06-06-14		1	Zoonoses			0.00
			Discussed Zoonotic potential of intestinal parasites- in particular roundworms.			
06-05-14	Kittens 6/5/14	1	FelLV/FIV ELISA in hosp	73.00	36.50	36.50 ** ✓
06-05-14		1	Feline Leukemia Elisa Negative			0.00 ✓
06-05-14		1	FIV Elisa Negative			0.00 ✓
06-05-14		1	Blood Draw Fee	15.00	7.50	7.50 ** ✓
06-05-14	<i>Andrew & Bethany</i>	2	CONSULT / EXAM - Annual Well n	99.00	49.50	49.50 ** ✓
06-05-14		2	Feline Rhino/Panleuk/Calici #1	50.00	25.00	25.00 ** ✓
			Your cat has received the first in a series of immunizations to protect him/her against feline distemper, rhinotracheitis, and calicivirus. It is important to return for a followup booster in 3-4 weeks. Occasionally listlessness, lethargy, or localized discomfort may occur. If there is severe listlessness or facial swelling, please call us for advice.			
06-05-14		2	RecommendFecal (please dropoff			0.00
			Annual fecal microscopic exams are very important for the health of your pet and, since some worms are transmissible to humans, for the health of your family. Please bring us your pet's fecal sample at your earliest convenience			

INVOICE

Newburgh Veterinary Hospital

1716 Route 300
Newburgh, NY 12550
845 564-2660

"Your pet is part of our family too." Visit us at www.newburghvet.com

FOR: Town of Newburgh - Feline
645 Gidney Ave.
Newburgh, NY 12550
(845) 561-3344

Printed: 07-01-14 at 1:24p
Date: 06-06-14
Account: 4417
Invoice: 576030

Date	For	Qty	Description	Price	Discount	Net Price	
06-06-14	3orange/1black	1	Revolution Cat 5.1-15lb (6 pack)	99.98	49.99	49.99	** ✓
06-06-14	Kittens 6/5/14	2	Revolution Pup/Kitten 1-5lbs (3 pk)	95.98	47.99	47.99	** ✓
						Total charges, this invoice...	97.98
						**Total discount included: 97.98	

Your invoice total reflects our **13Stray Cat Accounts** discount.

LIKE US ON FACEBOOK.COM!

GOING AWAY?....BOOK YOUR PETS BOARDING RESERVATION TODAY!

In compliance with New York State law, all medications are non-refundable. We regret any inconveniences.

INVOICE

Newburgh Veterinary Hospital

1716 Route 300
Newburgh, NY 12550
845 564-2660

"Your pet is part of our family too." Visit us at www.newburghvet.com

FOR: Town of Newburgh - Feline
645 Gidney Ave.
Newburgh, NY 12550
(845) 561-3344

Printed: 07-01-14 at 1:24p
Date: 06-11-14
Account: 4417
Invoice: 576376

Date	For	Qty	Description	Price	Discount	Net Price	
06-10-14	Blitz	1	CRYPT/MONORCHID-ABD/FEL	339.50	199.75	139.75	** ✓
06-10-14		1	-Isoflurane Gas Anesthesia			0.00	
06-10-14		1	X-RAY-Followup Views	93.00	46.50	46.50	** ✓
06-06-14	Carriage Kitten	1	FeLV/FIV ELISA in hosp	73.00	36.50	36.50	** ✓
06-06-14		1	FeLV/FIV ELISA in hosp	73.00	36.50	36.50	** ✓
06-06-14		6	Blood Draw Fee	90.00	45.00	45.00	**
06-06-14		2	Feline Leukemia Elisa Negative			0.00	
06-06-14		2	FIV Elisa Negative			0.00	
06-06-14		1	Amoxicillin Drops 15ml (50mg/ml)	18.60	9.30	9.30	** ✓
06-06-14	Kardel Kittens	1	Clavamox Drops #183421	36.00	18.00	18.00	** ✓
06-10-14		1	Clavamox Drops #183583	36.00	18.00	18.00	** ✓
06-11-14	Mickey D - 6/10	1	FeLV/FIV ELISA in hosp	73.00	36.50	36.50	** ✓
Total charges, this invoice...						386.05	
**Total discount included: 446.05							

Your invoice total reflects our **13Stray Cat Accounts** discount.

LIKE US ON FACEBOOK.COM!

GOING AWAY?....BOOK YOUR PETS BOARDING RESERVATION TODAY!

In compliance with New York State law, all medications are non-refundable. We regret any inconveniences.

INVOICE

Newburgh Veterinary Hospital

1716 Route 300
Newburgh, NY 12550
845 564-2660

"Your pet is part of our family too." Visit us at www.newburghvet.com

FOR: Town of Newburgh - Feline
645 Gidney Ave.
Newburgh, NY 12550
(845) 561-3344

Printed: 07-01-14 at 1:24p
Date: 06-12-14
Account: 4417
Invoice: 576449

Date	For	Qty	Description	Price	Discount	Net Price
06-11-14	Bethany 48K-14	1	Chemistry / CBC (SA020)	159.50	79.75	79.75 **
			Chemistry panel liver			
			Chemistry panel kidney			
			Chemistry panel pancreas			
			Veterinarian Interpretation +/- Consult			
			Speciman collection			
			White blood cell count			
			Red blood cell count			
			Packed cell volume			
			Differential cytology			
06-12-14		1	Amoxicillin Drops 15ml (50mg/ml)	18.60	9.30	9.30 **
06-12-14		1	Veterinarian's Notes			0.00
06-12-14		3	Oral medication administration			15.00
06-12-14		0.02	Unasyn Inject / ml (in hosp)	15.02	7.51	7.51 **
	6/11					
06-12-14		0.02	Unasyn Inject / ml (in hosp)	7.52	3.76	3.76 **
06-12-14		2	SUBCUTANEOUS FLUIDS INJEC	90.00	45.00	45.00 **
06-12-14		1	Weight Monitoring			0.00

Total charges, this invoice... 160.32

**Total discount included: 145.32

Your invoice total reflects our **13Stray Cat Accounts** discount.

LIKE US ON FACEBOOK.COM!

GOING AWAY?...BOOK YOUR PETS BOARDING RESERVATION TODAY!

In compliance with New York State law, all medications are non-refundable. We regret any inconveniences.

INVOICE

Newburgh Veterinary Hospital

1716 Route 300
Newburgh, NY 12550
845 564-2660

"Your pet is part of our family too." Visit us at www.newburghvet.com

FOR: Town of Newburgh - Feline
645 Gidney Ave.
Newburgh, NY 12550
(845) 561-3344

Printed: 07-01-14 at 1:23p
Date: 06-13-14
Account: 4417
Invoice: 576597

Date	For	Qty	Description	Price	Discount	Net Price
06-13-14	Kardel Kittens	1	Amoxicillin Drops 15ml (50mg/ml)	18.60	9.30	9.30 **
06-13-14		1	Erythromycin Ophthalmic Ointment	37.50	18.75	18.75 **
06-13-14		1	CONSULT / EXAM - Sick	59.50	29.75	29.75 **
06-13-14		1	Pet Insurance Review			0.00
Please visit www.petinsurancereview.com and dogtime.com for an independent review of all national pet health insurance plans						
06-13-14		1	NYS Mandated Biological Waste:	6.00	3.00	3.00 **
Total charges, this invoice...						60.80
**Total discount included: 60.80						

Your invoice total reflects our **13Stray Cat Accounts** discount.

LIKE US ON FACEBOOK.COM!

GOING AWAY?....BOOK YOUR PETS BOARDING RESERVATION TODAY!

In compliance with New York State law, all medications are non-refundable. We regret any inconveniences.

TOWN OF NEWBURGH

1496 Route 300
Newburgh, New York 12550
(845) 564-4552

DO NOT WRITE IN THIS BOX

DEPARTMENT _____

CLAIMANT'S
NAME
AND
ADDRESS

NEWBURGH VETERINARY HOSPITAL
1716 Route 300
Newburgh, NY 12550
Tel: (845) 564-2660
www.newburghvet.com

Date Voucher Received		VOUCHER NO.
FUND - APPROPRIATION	AMOUNT	
Total		
Abstract #		

TERMS Net 30 Days

Invoice # _____

Canine

Dates	Quantity	Description of Materials or Services	Unit Price	Amount
1/28/14	575336			112.50
2/2/14	575692			178.50
1/11/14	576375			213.50
2/12/14	576482			362.75
1/18/14	576880			28.50
TOTAL				895.75

CLAIMANT'S CERTIFICATION

I, Dora M Cast certify that the above account in the amount of \$ 895.75 is true and correct; that the items, services and disbursements charged were rendered to or for the municipality on the dates stated; that no part has been paid or satisfied; that taxes, from which the municipality is exempt, are not included; and that the amount claimed is actually due.

7/1/14
DATE

Dora M Cast
SIGNATURE

Bookkeeper
TITLE

(Space below for municipal use)

DEPARTMENT APPROVAL

The above services or materials were rendered or furnished to the municipality on the dates stated and the charges are correct.

Date

Authorized Official

APPROVAL FOR PAYMENT

This claim is approved and ordered for paid from the appropriations indicated above

Date

Auditing Board

INVOICE

Newburgh Veterinary Hospital

1716 Route 300
Newburgh, NY 12550
845 564-2660

"Your pet is part of our family too." Visit us at www.newburghvet.com

FOR: Town of Newburgh - canine
645 Gidney Ave
Newburgh, NY 12550
(845) 561-3344

Printed: 07-01-14 at 12:18p
Date: 06-12-14
Account: 19984
Invoice: 576482

Date	For	Qty	Description	Price	Discount	Net Price	
06-12-14	49-14 Champ	1	FECAL (ParasiteScreen) T808	29.50	14.75	14.75	** ✓
06-12-14	56-14 (chico)	1	4DX Elisa Negative			0.00	
06-11-14	Nadolny "patton	1	Chemistry in hospital Chemistry panel liver Chemistry panel kidney Chemistry panel pancreas Veterinarian Interpretation +/- Consult	149.50	149.50	0.00	** ✓
06-11-14		0.30	Morphine Inject Control Log / ml			0.00	
06-11-14		0.20	Telazol Injectable Control Log / ml			0.00	
06-11-14		1	Sevoflurane anesthesia	219.50	169.50	50.00	** ✓
06-11-14		1	-I.V.Cath. /subcut fluids during sur	63.50	31.75	31.75	** ✓
06-11-14		1	Pre-Anesth Chem <7yrs in hosp Chemistry panel liver Chemistry panel kidney Chemistry panel pancreas Veterinarian Interpretation +/- Consult Speciman collection Packed cell volume	89.00	44.50	44.50	** ✓
06-11-14	Riescher Dogs	2	NEUTER/CANINE <1YR	279.00	139.50	139.50	** ✓
06-11-14		2	-Isoflurane Gas Anesthesia			0.00	
06-12-14	Vanluwegen "Sab	1	Moved payment to account 22446			82.25	?
Total charges, this invoice...						362.75	
**Total discount included: 549.50							

Your invoice total reflects our **13Stray Cat Accounts** discount.

LIKE US ON FACEBOOK.COM!

INVOICE

Newburgh Veterinary Hospital

1716 Route 300
Newburgh, NY 12550
845 564-2660

"Your pet is part of our family too." Visit us at www.newburghvet.com

FOR: Town of Newburgh - canine
645 Gidney Ave
Newburgh, NY 12550
(845) 561-3344

Printed: 07-01-14 at 12:18p
Date: 06-18-14
Account: 19984
Invoice: 576880

Date	For	Qty	Description	Price	Discount	Net Price
06-17-14	RUGBY 57-14.	1	Lyme,HW,Ehrlichia Accu Plus4(AC	49.50	21.00	28.50 **
06-18-14		1	Heartworm Elisa Negative			0.00
06-18-14		1	Lyme Test Negative			0.00
06-18-14		1	Ehrlichia Canis Elisa negative			0.00

Total charges, this invoice... 28.50 ✓

**Total discount included: 21.00

Your invoice total reflects our **13Stray Cat Accounts** discount.

LIKE US ON FACEBOOK.COM!

GOING AWAY?...BOOK YOUR PETS BOARDING RESERVATION TODAY!

In compliance with New York State law, all medications are non-refundable. We regret any inconveniences.

For August 4th Agenda

On November 4th 2013 the Town of Newburgh approved \$ 24,800.00 for an audit to be performed by Vanacore DeBenedictus Digiovanni & Weddell the amount to approved should have been \$ 28,400.00 as Indicated on page three of the proposal.

I hereby request the board approve an additional \$ 3,600.00 to complete payment of this audit

Auditor
001-1320-0499

A handwritten signature, possibly "J. DeBenedictus", enclosed within a hand-drawn circle.

- 78 Susan Drive in the Town of Newburgh
- 28 Victoria Drive in the Town of Newburgh
- 3 Midway Drive in the Town of Newburgh

Councilman Piaquadio asked if these properties will be re-levied onto the owner's 2014 tax bill.

Mr. Taylor replied that the re-levy will appear on the 2014 tax roll.

11. ACCOUNTING: 2013 Audit Services

Supervisor Booth said the Town has used Vanacore, DeBenedictus, DiGovanni and Weddell's accounting services for the last three years. The amount of these services has remained the same as they were in 2012.

MOTION was made by Councilman Bello to approve the arrangement letter for the services, dated October 15, 2013, performed by Vanacore, DeBenedictus, DiGovanni, & Weddell, who are located in Newburgh, New York, for the services they will perform for the Town of Newburgh for the year ending December 31, 2013. The cost of these services is \$24,800.00. The motion was seconded by Councilman Piaquadio.

VOTE: Councilman Woolsey-yes; Councilman Piaquadio-yes; Councilwoman Greene-yes; Councilman Bello-yes; Supervisor Booth-yes

Motion passed: 5-yes; 0 no; 0 abstain; 0 absent

contract 28400.00

approve addtnl 3,600.00 in next meeting Aug 4, 2014

12. ANIMAL CONTROL:

A. T-94 Withdrawal(s)

Supervisor Booth said the T-94 account is a donation account with a balance of \$172,289.22.

MOTION was made by Councilman Woolsey to approve the request dated October 29, 2013, submitted by Chantel Haight, Animal Control Supervisor, to pay the veterinarian services vouchers, submitted by Flannery Animal Hospital for the following:

- Invoice # 108099, dated October 22, 2013, for the total amount of \$ 86.40
- Invoice # 106770, dated October 14, 2013, for the total amount of 1,106.00
- Invoice # 105424, dated October 2, 2013, for the total amount of 156.00

The motion was seconded by Councilman Bello.

VOTE: Councilman Woolsey-yes; Councilman Piaquadio-yes; Councilwoman Greene-yes; Councilman Bello-yes; Supervisor Booth-yes

Motion passed: 5-yes; 0 no; 0 abstain; 0 absent

B. Authorization to Hire Part Time Animal Shelter Helper

MOTION was made by Councilwoman Greene to approve the request dated October 29, 2013, submitted by Charlene Black, Personnel, selected by Chantel Haight, Animal Control Supervisor, to hire Guy Venzke, as a part-time Animal Shelter Helper at a pay rate of \$10.00, effective November 14, 2013, pending the pre-employment physical, fingerprints, drug/alcohol testing and paperwork. The motion was seconded by Councilman Piaquadio



VANACORE
DeBENEDICTUS
& DiGOVANNI
WEDDELL

LIMITED LIABILITY PARTNERSHIP

BUSINESS DEVELOPMENT CONSULTANTS CERTIFIED PUBLIC ACCOUNTANTS
11 RACQUET ROAD, P.O. BOX 10009 • NEWBURGH, NY 12552-0009

October 15, 2013

Town Board
Town of Newburgh
1469 Route 300
Newburgh, NY 12550

Attention: Mr. Wayne Booth

APPROVED

Date of Town Board Action: NOV - 4 2013

Vote of Town Board: 5-0

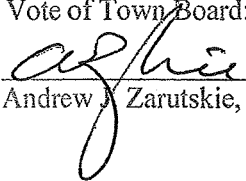
Andrew J. Zarutskie, Town Clerk

The Objective and Scope of the Audit of the Financial Statements

You have requested that we audit the financial statements of Town of Newburgh (the "Town"), which comprise governmental activities, each major fund and aggregate remaining fund information as of and for the year-ended December 31, 2013 which collectively comprise the basic financial statements. We are pleased to confirm our acceptance and our understanding of this audit engagement by means of this letter.

Our audit will be conducted with the objective of our expressing an opinion on the financial statements.

The Responsibilities of the Auditor

We will conduct the audit in accordance with auditing standards generally accepted in the United States of America and "Government Auditing Standards" issued by the Comptroller General of the United States. Those standards require that we plan and perform the audit to obtain reasonable, rather than absolute, assurance about whether the financial statements are free of material misstatement. An audit involves performing procedures to obtain audit evidence about the amounts and disclosures in the financial statements. The procedures selected depend on the auditor's judgment, including the assessment of the risks of material misstatement of the financial statements, whether due to fraud or error. An audit also includes evaluating the appropriateness of accounting policies used and the reasonableness of significant accounting estimates made by management, as well as evaluating the overall presentation of the financial statements.

Because of the inherent limitations of an audit, together with the inherent limitations of internal control, an unavoidable risk that some material misstatements may not be detected exists, even though the audit is properly planned and performed in accordance with GAAS. Also, an audit is not designed to detect errors or fraud that are immaterial to the financial statements. The determination of abuse is subjective; therefore, Government Auditing Standards do not expect us to provide reasonable assurance of detecting abuse.

In making our risk assessments, we consider internal control relevant to the Town's preparation and fair presentation of the financial statements in order to design audit procedures that are appropriate in the circumstances but not for the purpose of expressing an opinion on the effectiveness of the entity's internal control. However, we will communicate to you in writing concerning any significant deficiencies or material weaknesses in internal control relevant to the audit of the financial statements that we have identified during the audit.

We will also communicate to the Town Board (a) any fraud involving senior management and fraud (whether caused by senior management or other employees) that causes a material misstatement of the financial statements that becomes known to us during the audit, and (b) any instances of noncompliance with laws and regulations that we become aware of during the audit (unless they are clearly inconsequential).

The funds that you have told us are maintained by the Town and that are to be included as part of our audit are listed here.

- * General Fund
- * Highway Fund
- * Water Fund
- * Sewer Fund
- * Drainage Fund
- * Capital Projects Fund
- * Lighting Fund
- * Agency Fund

Our report on internal control will include any significant deficiencies and material weaknesses in controls of which we become aware as a result of obtaining an understanding of internal control and performing tests of internal control consistent with requirements of the standards and circulars identified above. Our report on compliance will address material errors, fraud, abuse, violations of compliance requirements, and other responsibilities imposed by state and federal statutes and regulations and assumed by contracts; and any state or federal grant, entitlement or loan program questioned costs of which we become aware, consistent with requirements of the standards identified above.

Town of Newburgh's Responsibilities and Identification of the Applicable Financial Reporting Framework

Our audit will be conducted on the basis that management and, when appropriate, those charged with governance acknowledge and understand that they have responsibility:

- a. For the preparation and fair presentation of the financial statements in accordance with accounting principles generally accepted in the United States of America;
- b. For the design, implementation, and maintenance of internal control relevant to the preparation and fair presentation of financial statements that are free from material misstatement, whether due to fraud or error; and
- c. To provide us with:
 - (1) Access to all information of which management is aware that is relevant to the preparation and fair presentation of the financial statements such as records, documentation, and other matters;
 - (2) Additional information that we may request from management for the purpose of the audit; and
 - (3) Unrestricted access to persons within the entity from whom we determine it necessary to obtain audit evidence.

As part of our audit process, we will request from management and, when appropriate, those charged with governance written confirmation concerning representations made to us in connection with the audit including among other items:

- a. That management has fulfilled its responsibilities as set out in the terms of this letter; and
- b. That it believes the effects of any uncorrected misstatements aggregated by us during the current engagement and pertaining to the latest period presented are immaterial, both individually and in the aggregate, to the financial statements taken as a whole.

Management is responsible for identifying and ensuring that the Town complies with the laws and regulations applicable to its activities, and for informing us about all known material violations of such laws or regulations. In addition, management is responsible for the design and implementation of programs and controls to prevent and detect fraud, and for informing us about all known or suspected fraud affecting the Town involving management, employees who have significant roles in internal control, and others where the fraud could have a material effect on the financial statements or compliance. Management is also responsible for informing us of its knowledge of any allegations of fraud or abuse or suspected fraud or abuse affecting the Town received in communications from employees, former employees, participants, regulators, analysts, short sellers, or others.

The Town Board is responsible for informing us of its views about the risks of fraud or abuse within the Town, and its knowledge of any fraud or abuse or suspected fraud or abuse affecting the Town.

Because Vanacore, DeBenedictus, DiGiovanni and Weddell, LLP will rely on Town of Newburgh and its management and Town Board to discharge the foregoing responsibilities, Town of Newburgh holds harmless and releases Vanacore, DeBenedictus, DiGiovanni and Weddell, LLP, its partners, and employees from all claims, liabilities, losses, and costs arising in circumstances where there has been a knowing misrepresentation by a member of Town of Newburgh's management which has caused, in any respect, Vanacore, DeBenedictus, DiGiovanni and Weddell, LLP's breach of contract or negligence. This provision shall survive the termination of this arrangement for services.

Town's Records and Assistance

If circumstances arise relating to the condition of the Town's records, the availability of appropriate audit evidence, or indications of a significant risk of material misstatement of the financial statements because of error, fraudulent financial reporting, or misappropriation of assets which, in our professional judgment, prevent us from completing the audit, we retain the unilateral right to take any course of action permitted by professional standards, including declining to express an opinion, issue a report or withdrawal from the engagement.

During the course of our engagement, we may accumulate records containing data that should be reflected in the Town's books and records. The Town will determine that all such data, if necessary, will be so reflected. Accordingly, the Town will not expect us to maintain copies of such records in our possession.

The assistance to be supplied by Town personnel, including the preparation of schedules and analyses of accounts, will be discussed and coordinated with you. The timely and accurate completion of this work is an essential condition to our completion of the audit and issuance of our audit report.

Other Relevant Information

From time to time and depending upon the circumstances, we may use third-party service providers to assist us in providing professional services to you. In such circumstances, it may be necessary for us to disclose confidential client information to them. We enter into confidentiality agreements with all third-party service providers and we are satisfied that they have appropriate procedures in place to prevent the unauthorized release of your confidential information to others.

Fees, Costs, and Access to Workpapers

Our fees for the audit and accounting services described above are based upon the value of the services performed and the time required by the individuals assigned to the engagement, plus direct expenses. We propose that our fee for this audit engagement will be \$28,400 for the year ending December 31, 2013. Our fee estimate and completion of our work is based upon the following criteria:

- a. Anticipated cooperation from Town personnel
- b. Timely responses to our inquiries
- c. Timely completion and delivery of client assistance requests
- d. Timely communication of all significant accounting and financial reporting matters
- e. The assumption that unexpected circumstances will not be encountered during the engagement

If any of the aforementioned criteria are not met, then fees may increase. Interim billings will be submitted as work

progresses and as expenses are incurred. Billings are due upon submission.

It is agreed by the Town of Newburgh and Vanacore, DeBenedictus, DiGovanni & Weddell, LLP that, should you hire any of our professionals assigned to this project within eighteen months of this assignment, you will be billed 100 percent of their current annual salary. This additional fee is being charged to offset recruitment, training and development expenses we would incur to replace this person. In addition, our professional standards require that we perform certain additional procedures, on current and previous years' engagements, whenever a partner or professional employee leaves the firm and is subsequently employed by, or associated with, a client in a key position.

Accordingly, the Town agrees it will compensate Vanacore, DeBenedictus, DiGovanni & Weddell, LLP for any additional costs incurred as a result of the Town's employment of a partner or professional employee of Vanacore, DeBenedictus, DiGovanni & Weddell, LLP.

In the event we are requested or authorized by Town of Newburgh, or are required by government regulation, subpoena, or other legal process, to produce our documents or our personnel as witnesses with respect to our engagement for Town of Newburgh, the Town of Newburgh will, so long as we are not a party to the proceeding in which the information is sought, reimburse us for our professional time and expenses, as well as the fees and expenses of our counsel, incurred in responding to such requests.

Claim Resolution

Town of Newburgh and Vanacore, DeBenedictus, DiGovanni and Weddell, LLP agree that no claim arising out of services rendered pursuant to this agreement shall be filed more than two years after the date of the audit report issued by Vanacore, DeBenedictus, DiGovanni and Weddell, LLP or the date of this arrangement letter if no report has been issued. Town of Newburgh waives any claim for punitive damages. Vanacore, DeBenedictus, DiGovanni and Weddell, LLP's liability for all claims, damages and costs of Town of Newburgh arising from this engagement is limited to the amount of fees paid by Town of Newburgh to Vanacore, DeBenedictus, DiGovanni and Weddell, LLP for the services rendered under this arrangement letter.

If any dispute arises among the parties hereto, the parties agree first to try in good faith to settle the dispute by mediation administered by the American Arbitration Association under its Rules for Professional Accounting and Related Services Disputes before resorting to litigation. The costs of any mediation proceeding shall be shared equally by all parties.

Reporting

We will issue a written report upon completion of our audit of Town of Newburgh's financial statements. Our report will be addressed to the Town Board of Town of Newburgh. We cannot provide assurance that an unmodified opinion will be expressed. Circumstances may arise in which it is necessary for us to modify our opinion, add an emphasis-of-matter or other-matter paragraph(s), or withdraw from the engagement.

Our report on internal control will include any significant deficiencies and material weaknesses in controls of which we become aware as a result of obtaining an understanding of internal control consistent with requirements of the standards identified above. Our report on compliance will address material errors, fraud and abuse of which we become aware, consistent with requirements of the standards identified above.

This letter constitutes the complete and exclusive statement of agreement between Vanacore, DeBenedictus, DiGovanni and Weddell, LLP and Town of Newburgh, superseding all proposals, oral or written, and all other communications, with respect to the terms of the engagement between the parties.

Town of Newburgh

October 15, 2013

Page 5

In accordance with *Government Auditing Standards*, a copy of our most recent peer review report has been provided for your information.

Please sign and return the attached copy of this letter to indicate your acknowledgment of, and agreement with, the arrangements for our audit of the financial statements, including our respective responsibilities. We appreciate your business.

Sincerely,

VANACORE, DeBENEDICTUS, DiGOVANNI & WEDDELL
Limited Liability Partnership

 Tonia A. Crown, CPA-CITP

Tonia A. Crown, CPA.CITP
Partner

Confirmed on behalf of the addressee:

Mr. Wayne Booth

Date

On June 26, 2014 Robert Conflitti from the Orange County District Attorney's Office requested a member of our Town Board be appointed to the Orange County District Attorney's Advisory Board.

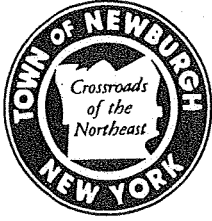

TOWN OF NEWBURGH

1496 Route 300, Newburgh, New York 12550

Brenda
18

PERSONNEL DEPT.

PH: 845-566-7785
Fax: 845-564-2170

To: Gilbert Piaquadio, Deputy Town Supervisor
Town Board

From: Charlene M Black, Personnel

Date: July 31, 2014

Re: Employees Assistance Program

As you are aware, we spoke about an Employee Assistance Program that our employees are entitled to. We had a program in place years ago and for some reason it was not kept current. The company we used was taken over by Corporate Services EAP (Catholic Charities Community Services of Orange County). I spoke to the contract manager and she prepared a proposal for your approval. Please see attached.

It is imperative that we have this program in place for our employees. It is in both our Union Contracts and is offered to our management and part time employees. The funding will come out of the medical budget.

Thank you in advance.

PROPOSAL

Employee Assistance Program

for

TOWN OF NEWBURGH

from

Corporate Services EAP

a program of

Catholic Charities Community Services of Orange County

July 31, 2014

Purpose

This proposal is offered to the **Town of Newburgh** in order to make Employee Assistance Program services available to its employees. Comprehensive assessment and referral support and services will be provided in relation to non-medical personal and family problems that may adversely affect work performance and employee welfare. **Corporate Services EAP** proposes to provide these services as described herein to the satisfaction of Town of Newburgh and its employees.

Our proposed approach encompasses two sets of activities:

- Working with Town of Newburgh managers and supervisors to enhance their ability, as supervisors, to identify employees who may be dealing with personal problems themselves, or within their families, and appropriately approach such employees regarding intervention; and
- Providing and arranging assessment and referral services with follow-up on a confidential basis for employees who are referred to the EA Program or voluntarily seek assistance. The objective in these instances is to enhance the performance, welfare and retention of all valuable employees of the Town of Newburgh.

Proposed Services

Organizational Assessment, Training and Ongoing Follow-up and Support

1. Corporate Services EAP will conduct a needs assessment in collaboration with Town of Newburgh managers and supervisors in order to identify specific internal concerns related to this EA Program and ensure that they are addressed during program implementation.
2. Corporate Services EAP will provide initial, in-person, organizational and supervisory orientation sessions in collaboration with management and will distribute informational brochures and contact information for each employee.
3. Corporate Services EAP, in collaboration with Town of Newburgh management, will analyze organizational and supervisory training needs that are to be addressed through ongoing leadership training. Two (2) relevant leadership training sessions will then be established and delivered in-person on a semi-annual basis by Corporate Services EAP. Additional leadership training sessions can be added on an incremental fee basis either on an annual, pre-planned basis or on an as-needed basis. A list of possible workshop topics is enclosed.
4. Corporate Services EAP will provide utilization reports on a quarterly basis, showing program utilization rates and data on utilization by problem type, referral source, and demographic grouping, while maintaining employee confidentiality.

Employee Services

1. Employees and members of their immediate household with personal or family problems will be provided the following:
 - Professional assessment and referral services by clinicians licensed in their field of practice. Typically up to three sessions are provided at no cost to the employee/client at a professional site convenient to the employee's residence or place of work, as requested by the employee. All assessment, counseling and referral will be conducted face-to-face between the employee and the clinician.

Requests for assessment and referral services can be initiated by employees themselves by calling our toll free phone number or by Town of Newburgh supervisors, making either an encouraged referral or a mandated referral. In the latter case, Corporate Services will keep Town of Newburgh management informed of the employee's ongoing participation in accordance with policies of the Town of Newburgh.

- An employee's initial appointment with a clinician will typically be scheduled by Corporate Services EAP within three business days of the employee's request unless it is an emergency, in which case the appointment will be scheduled within 24 hours.
2. Affiliate clinicians will make every effort to refer clients needing extended treatment to professionals covered by the employee's insurance, whenever possible.
 3. Corporate Services EAP utilizes a network of 150 licensed affiliates and selects those best suited to each employee's specific needs. These affiliates have been selected and proven in fulfilling EA program needs for Corporate Services EAP throughout the Hudson Valley for more than 25 years.
 4. On-call emergency assistance will be accessible 24 hours per day, 7 days per week, including holidays.
 5. Corporate Services EAP is available and responsive in times of an organizational crisis during which we will make every effort to provide services appropriate and responsive for the crisis situation.

Fees

Corporate Services EAP proposes to provide EAP services for Town of Newburgh and its 220 full and part time employees at an annual fee of \$5,390.00. This fee will be in effect for 12 months and, if agreeable to both parties, extended with any adjustments in fee based on changes in the number of employees to be covered or changes in services to be provided for subsequent periods. EAP services provided under this Agreement are non-denominational in nature; funds provided to Corporate Services under this Agreement are not used for any religious purposes.

General

Corporate Services EAP sees successful introduction, participation and continuation of this Employee Assistance Program as an essential endeavor that is incumbent on Corporate Services EAP to effectively provide and maintain in collaboration and cooperation with Town of Newburgh, whose involvement is also necessary for this program's success.

Corporate Services EAP has been serving the Hudson Valley and the surrounding areas for more than 25 years. Our parent organization, Catholic Charities Community Services of Orange County, is committed in numerous ways to the region's communities as evidenced by our ongoing work with and support for all: children; families; employees; employers; schools; mental health providers; social service agencies; health care providers; government agencies and housing providers.

Corporate Services EAP will be happy to provide references among our current employers so that Town of Newburgh can be assured of our history in providing these services since the early 1980's.

Enclosure: Sample workshop topics

EAP

*Make certain
your staff
know about
their
EAP*

Your EAP has developed various workshops and trainings which we offer to our contract companies at no additional cost. The topics deal with issues some of which are intended specifically for management/supervisory personnel while others are appropriate for the general employee population. They can compliment your regular organizational training agenda. They can be tailored both in terms of time and content to fit your particular needs.

Organizational Trainings

PARTIAL LIST OF WORKSHOP TOPICS THAT THE EAP WILL PROVIDE YOUR ORGANIZATION



- ◆ Constructive Intervention
- ◆ Management Training
- ◆ Creating a Civil Work Environment
- ◆ Anger Management
- ◆ Domestic Violence
- ◆ Sexual Harassment
- ◆ Enhancing Supervisory Skills
- ◆ Managing Stress
- ◆ Making Change Work For You
- ◆ Effective Communication
- ◆ Addiction in the Workplace
- ◆ Time Management
- ◆ Coping with Shift Work

- ◆ Relaxation Techniques
- ◆ De-Clutter your Mind
- ◆ Budgeting for Today, Planning for Tomorrow

Your Employee Assistance Program is committed to making our services available to all those who may need them. To achieve this we must rely on you to assist us in remaining visible within YOUR ORGANIZATION: to distribute the promotional literature we provide and to schedule EAP staff trainings. One EAP training could make a "world of difference" in a co-workers life. To contact your EAP in order to schedule a training or presentation please call

1-800-962-7487