

JOSEPH P. PEDI
Town Clerk, 1496 Route 300
Town of Newburgh, New York 12550
Telephone 845-564-4554

WORKSHOP MEETING AGENDA
Monday, January 27, 2020
7:00 p.m.

1. ROLL CALL
2. PLEDGE OF ALLEGIANCE TO THE FLAG
3. MOMENT OF SILENCE
4. CHANGES TO AGENDA
5. POLICE DEPARTMENT:
 - A. Promotion of Sergeant
 - B. Approval to Hire Two Part Time Dispatchers
6. APPROVAL OF AUDIT
7. GRANT: Orange Lake Homeowners' Association
8. PRESENTATION: Darrigo Solar Farm
9. ZONING TEXT AMENDMENT PETITION: Building Blocks Child Care Center
10. RECREATION DEPARTMENT:
 - A. Chadwick Lake Park Concert Series
 - B. Sealed Bid Request for Chadwick Lake Park Grounds Maintenance
 - C. Sealed Bid Request for Busing for Year 2020
 - D. Approval to Accept Quote for Printing of Annual Program Brochure for Year 2020
 - E. Approval to Exercise Option to Select Firework's Bid
 - F. Approval to Hire Part Time Chauffeur
11. WATER AND SEWER DEPARTMENT:
 - A. Approval to Hire Wasterwater Maintenance Worker
 - B. Budget Transfer
12. ENGINEERING:
 - A. Rock Cut Estates - Three Lots and Common Driveway
 - B. Partial Release of Landscape Security for McDonald's
13. HIGHWAY DEPARTMENT:
 - A. Budget Transfer Request
 - B. Approval to Hire Part Time Laborer
 - C. Approval to Purchase Tandem Plow Truck
 - D. Approval to Purchase Super Cab
 - E. Sealed Bid Request for Summer Material, Cold Milling Machine, Tree Cutting and Brush Grinding
 - F. Sealed Bid Request for Truck Body and Plow for the Tandem Class 8 Truck
 - G. Approval to Hire Two Full Time MEO 1As
14. ANIMAL CONTROL: T-94 Withdrawal
 - A. Approval of First Payment to Newburgh Veterinary Hospital
 - B. Approval of Second Payment to Newburgh Veterinary Hospital
 - C. Approval of Payment to Walden Humane Society
 - D. Approval of Payment to Flannery Animal Hospital
15. TREE PRESERVATION LOCAL LAW – Schedule Public Hearing
16. JUSTICE COURT: Resolution Acknowledging Records and Documents
17. BUILDINGS AND GROUNDS:
 - A. Approval to Hire Part Time Custodial Worker
 - B. Award Contract for Garbage and Recyclable Collection
18. UNIFIRST CORPPORATION: Stormwater Control Facility Maintenance Agreement
19. ACCOUNTING: Budget Transfers
20. EXECUTIVE SESSION: Purchase of Property for Water District
21. ADJOURNMENT

GJP;jpp
First Revision: January 23, 2020 1:32 pm

5B



TOWN OF NEWBURGH

1496 Route 300, Newburgh, New York 12550

PERSONNEL DEPT.

PH: 845-566-7785
Fax: 845-564-2170

To: Supervisor Piaquadio ✓
Town Council

From: Charlene M Black, Personnel

Date: January 2, 2020

Re: Part-time Dispatcher

Chief Campbell is requesting authorization to hire two part time dispatchers: Timothy O'Connell and Joshua Wendell. Mr O'Connell is a seasonal employee with the Recreation department so he will need a physical, drug/alcohol testing and paperwork to be completed. As for Mr Wendell he will have to have his fingerprints done and all the other requirements. A proposed hire date on or after of February 3rd, 2020 is expected.



TOWN OF NEWBURGH POLICE DEPARTMENT

300 Gardnertown Road, Newburgh, New York 12550

DONALD B. CAMPBELL
CHIEF OF POLICE

Phone: (845) 564-1100
Fax: (845) 564-1870

December 27, 2019

To: Newburgh Town Board

Cc: Charlene Black/Personnel Department

From: Chief Donald B. Campbell

Subject: Part-Time Dispatcher Position

I am requesting authorization to hire Timothy O'Connell as a part-time dispatcher at a rate of \$13.52 per hour not to exceed an average of 20 hours per week or 1040 hours in any calendar year. I am requesting he receive a start date effective on or after February 3, 2020 pending a physical exam and fingerprinting. This is a budgeted position that is currently vacant (Fund appropriation # 001-3120-0100-000).

Respectfully submitted,

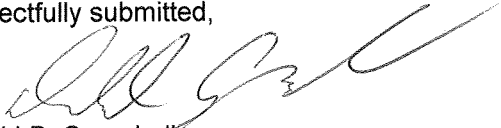
Donald B. Campbell
Chief of Police

TOWN OF NEWBURGH

EMPLOYMENT REQUEST FORM

To: Personnel Department

NAME OF CANDIDATE: Timothy O'Connell

DEPARTMENT: Police Department

TITLE OF POSITION: Dispatcher

FULL TIME OR PART TIME: PT

HOURLY RATE: \$13.52 per hour

IS POSITION FUNDED IN CURRENT BUDGET: YES OR NO

FUND APPROPRIATION NUMBER: 001-3120-0100-000

PROPOSED HIRE DATE: 2/3/2020

NOTE: CANDIDATE CANNOT BEGIN WORK WITHOUT PRE-EMPLOYMENT PHYSICAL AND COMPLETION OF ALL REQUIRED PAPERWORK.

[Signature]
DEPARTMENT HEAD SIGNATURE

1/2/2020
DATE

ORIGINAL APPLICATION SHOULD BE ON FILE IN THE PERSONNEL DEPARTMENT



TOWN OF NEWBURGH POLICE DEPARTMENT

300 Gardnertown Road, Newburgh, New York 12550

DONALD B. CAMPBELL
CHIEF OF POLICE

Phone: (845) 564-1100
Fax: (845) 564-1870

December 27, 2019

To: Newburgh Town Board

Cc: Charlene Black/Personnel Department

From: Chief Donald B. Campbell

Subject: Part-Time Dispatcher Position

I am requesting authorization to hire Joshua Wendell as a part-time dispatcher at a rate of \$13.52 per hour not to exceed an average of 20 hours per week or 1040 hours in any calendar year. I am requesting he receive a start date effective on or after February 3, 2020 pending a physical exam and fingerprinting. This is a budgeted position that is currently vacant (Fund appropriation # 001-3120-0100-000).

Respectfully submitted,

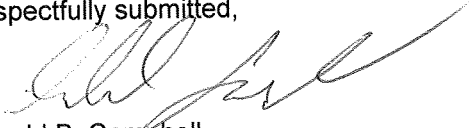

Donald B. Campbell
Chief of Police

TOWN OF NEWBURGH

EMPLOYMENT REQUEST FORM

To: Personnel Department

NAME OF CANDIDATE: Joshua Wendell

DEPARTMENT: Police Department

TITLE OF POSITION: Dispatcher

FULL TIME OR PART TIME: PT

HOURLY RATE: \$13.62 per hour

IS POSITION FUNDED IN CURRENT BUDGET: YES OR NO

FUND APPROPRIATION NUMBER: 001-3120-0100-000

PROPOSED HIRE DATE: on or after 2/3/2020

NOTE: CANDIDATE CANNOT BEGIN WORK WITHOUT PRE-EMPLOYMENT PHYSICAL AND COMPLETION OF ALL REQUIRED PAPERWORK.

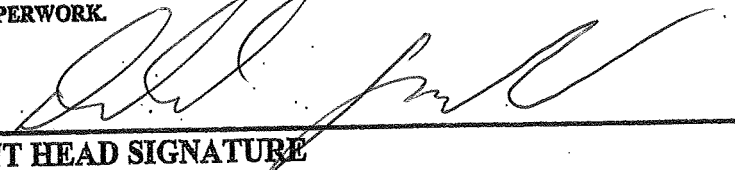
DEPARTMENT HEAD SIGNATURE

1/2/2020
DATE

ORIGINAL APPLICATION SHOULD BE ON FILE IN THE PERSONNEL
DEPARTMENT

C.T. MALE ASSOCIATES

Engineering, Surveying, Architecture, Landscape Architecture & Geology, D.P.C.

12 Raymond Avenue, Poughkeepsie, New York 12603
845.454.4400 www.ctmale.com

January 3, 2020

Dahlia Bartz Cabe and Fellow Board Members
 Orange Lake Homeowners Association
 12 Snider Avenue
 Walden, NY 12586

VIA EMAIL

Re: *Proposal*
Implementation of the Orange County Water Authority/Town of Newburgh Alternative
Water Supply Connection Grant
West Side Orange Lake
Orange County, New York

Dear Ms. Cabe and Fellow Board Members:

Jim Thatcher and I thank you for lunch at the Lakeview House on December 4, 2019. We believe it was a productive discussion and are pleased to provide you with this proposal to implement the Orange County Water Authority Grant to evaluate the feasibility of connecting to existing nearby water supplies. C.T. Male Associates Engineering, Surveying, Architecture, Landscape Architecture & Geology, D.P.C. (C.T. Male) recommends the following scope of work to evaluate whether there is an alternative that could be implemented cost effectively to improve drinking water quality for the West Side of Orange Lake.

The results of a prior feasibility study performed by the Town of Newburgh indicated that the West Side Orange Lake Homeowners could not readily connect to the Town of Newburgh water supply, but Jim Osborne, the Town's water and sewer Superintendent indicated that there may be other nearby water supplies that could be used. You currently have a grant from the Orange County Water Authority to evaluate these other potential connection(s). The grant must be administered through the Town of Newburgh and the OCWA.

Scope

C.T. Male recommends the following scope of services:

Task 1 - Preparation of a Base Map; Development of Water Supply Requirements: C.T. Male will prepare a base map for the West Side Orange Lake area that can be used to identify connection points, water line pathways, etc. This map will provide the basis for future grant preparation and engineering efforts.

C.T. MALE ASSOCIATES

*Ms. Cabe and Fellow Board Members
January 3, 2020
Page - 2*

We will calculate typical demand requirements for the Association including potential additional developments in the project area. This demand value will establish the number a gallons per day that would be required to support current and future development from an offsite water supply.

Task 2 - Connection Opportunities: There are several existing unused or underused water supplies located in proximity to the WSOL HOA. We will review readily available information to determine if they have surplus capacity to provide the WSOL HOA with water. We will determine the costs to pipe the water to the homeowners.

Task 3 - Alternatives Analysis: Once the feasibility and costs are developed for the adjacent connection potential, we will prepare a feasibility study that includes a comparison of alternative solutions to address the problem (e.g., a local waste water treatment plant).

Task 4 - Preliminary Strategy and Future Grant Opportunities: Depending upon the options that are most feasible for the homeowners, we will recommend a strategy to secure funding assistance to aid the WSOL HOA with solving the water connection problem and develop potential funding options and requirements to prepare the HOA to pursue appropriate financing for implementation.

Task 5 - Presentation to the Board and Public: The finding of our assessment may be of interest to the Board and the public. Whatever strategy is developed to address the water quality issue must have acceptance from those stakeholders who will be impacted by this process. We will present the results for discussion and modify the results of Task 4 accordingly. We anticipate one general meeting with the Board and a presentation to any interested homeowners, if the Board requests it.

Task 6 - The Path Forward: Based on input from the Board and the homeowners, we will prepare a recommended course of action to provide a solution to the water quality issue. Please note that we will coordinate future efforts with other interested parties (e.g., Quassaic Creek Watershed Alliance, Riverkeeper, etc.) because of their interest in addressing overall water quality issues in Orange Lake. Coalitions of private citizen action groups and governmental agencies increase the potential to secure grant funding.

C.T. MALE ASSOCIATES

*Ms. Cabe and Fellow Board Members
January 3, 2020
Page - 3*

Project Schedule and Fee

C.T. Male will complete this scope of work, including a written report to the Board and a minimum of one public presentation, for a not to exceed amount equal to the existing grant limit (\$9,400). We anticipate completing this work by June 1, 2020. The work can be done sooner if desired; however, the current schedule is intended to coincide with the State's next large grant application round and presumes that there will be a strategic plan regarding the path forward in place by then.

Authorization

If this Proposal is acceptable, please sign and return the attached Contract Agreement. We recognize that you also will have to enter into a contract agreement for the grant with the Town of Newburgh. We will not proceed with any of the above-referenced scope of work until that agreement is in place. A signed copy of our agreement and a copy of your contract with the Town will serve as our authorization to proceed.

Again, we appreciate the opportunity to work with you. Please do not hesitate to contact me at (845) 454-4400 or via email at j.mciver@ctmale.com or Jim Thatcher at j.thatcher@ctmale.com if you have questions.

Respectfully,
C.T. MALE ASSOCIATES

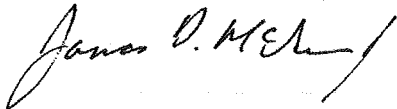

James D. McIver, Jr., P.G.
Managing Geologist/Branch Manager

Enc: Contract Agreement

Ec: Jim Thatcher, Project Manager, C.T. Male
Chad Kortz, P.E., C.T. Male
Jolanda Jansen, P.E., C.T. Male.

Town of Newburgh
State of New York : County of Orange

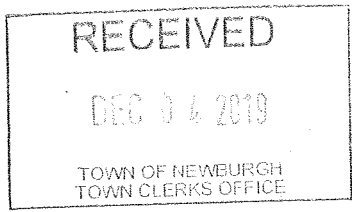

-----X

In the matter of the application of

Building Blocks Child Care Center, Inc.,

Petitioner,

**PETITION FOR
ZONING AMENDMENT**

For an amendment to the Zoning Code of the Town
Of Newburgh to add "Nursery School for Pre-School
Children" as a use permitted in all "B" Zoning Districts
subject to grant of site plan approval and a special use
permit.

-----X

**TO THE TOWN BOARD OF THE TOWN OF NEWBURGH, COUNTY OF
ORANGE, STATE OF NEW YORK:**

Petitioner, Building Blocks Child Care Center, Inc., respectfully requests that the Town
Board of the Town of Newburgh enact a local law amending the Town Code, Chapter 185,
"Zoning", Table of Use and Bulk Requirements, B District, to add the use of Nursery School For
Pre-School Children as a use permitted in all "B" Zoning Districts subject to grant of site plan
approval.

(A.) The Petitioner

1. Building Blocks Child Care Center, Inc., ("Petitioner") is a domestic
corporation organized and existing in the State of New York, with an address at 248
Lakeside Road, Newburgh, New York 12550.

2. The Petitioner is the owner of a certain real property located at 248
Lakeside Road, Newburgh, New York 12550 which is identified on the Town Tax Map as
Section 51, Block 10, Lot 11.1 (the "subject" property").

3. The subject property consists of 1.05 acres. It is improved by a main building of approximately 69' x 70' and an approximately 36' x 16' accessory building. These buildings were originally constructed by and used for the Dan Leghorn Engine Company No. 1.

4. The subject property is located within a "Business" ("B") zoning district.

5. In or about 1996, the Dan Leghorn Engine Company No. 1 moved to its new location on Route 52 (i.e., 426 South Plank Road, Newburgh, New York 12550) and put the subject property up for sale

6. In 1997, the Petitioner acquired title to the subject property. A use variance and area variances, as well as site plan approval, was granted to the Petitioner by the Town for establishment of a Nursery School for Pre-School Children on the subject property. Copies of the Petitioner's deed and the Use & Area Variance are attached as Exhibits "A" and "B".

7. The Petitioner then established a Nursery School for Pre-School Children on the subject property in the main building on the property and has operated the same continuously since 1997.

8. The Petitioner used the accessory building on the subject property for storage in connection with the Nursery School use. In 2007, the Petitioner applied for amended site plan approval to use the accessory building as a classroom for students/attendees.

9. The Town Planning Board referred the Petitioner's application to the Town Zoning Board of Appeals ("ZBA") for an interpretation as to whether the use variance previously granted to the Petitioner extended to use of the accessory building for housing student/attendee activities.

10. After the ZBA conducted a public hearing on the application, a "motion" was made as follows:

"I think we discussed every side of that. I don't see it being part of that use variance and I don't think we are allowed to cramp something of that nature where you have two independent buildings on the same lot, even if it is conducting the same business or businesses."

Without discussion the ZBA voted to approve the "motion" to find that the previously granted use variance did not extend to use of the accessory building for housing student/attendee activities. No formal resolution or findings were ever adopted by the ZBA on the Petitioner's application. A copy of the minutes of the ZBA's decision is attached as Exhibit "C".

11. In 2008, the Petitioner applied to the ZBA for a rehearing on the request for an interpretation. On the application, the Petitioner pointed out that, when no conditions or limitations are imposed by the ZBA on a use variance, the use variance extends *to the entire property*. 3 Salkin, *New York Zoning Law & Practice*, §29.02, p. 29-6; 3 Rathkopf, *The Law a Zoning & Planning*, §58:23; *In re Angel Plants, Inc. v. Schoenfeld*, 154 A.D.2d 459, 546 N.Y.S.2d 112 (2nd Dept. 1989); *In re Borer v. Vindeberg*, 213 A.D. 2d 828, 623 N.Y.S.2d 378 (3rd Dept. 1995); *In re Jame v. Town of New Hartford*, 49 A.D. 2D 373, 373 N.Y.S.2d 939 (4th Dept. 1975). That is, since the variance previously granted by ZBA had not imposed any conditions limiting child care to only the main building on the Petitioner's property, the use variance that had previously been granted for the subject property extended to use of the accessory building as a classroom for students/attendees, subject to site plan approval, a matter of law. In short, the ZBA's decision denying the requested interpretation was very clearly in error.

12. The vote of the ZBA on Petitioner's application for a rehearing to correct the ZBA's clearly erroneous prior decision was 6-1 in favor, with the lone vote in opposition to the rehearing being cast by ZBA member who had made the above-quoted motion on interpretation.

However, by law, a unanimous vote of the ZBA was required for grant of a rehearing on the ZBA's prior decision. (See Town Law §267-a(12)). As a result, the ZBA's prior decision stood.

(B.) The Requested Zoning Amendment

13. The Petitioner's business has grown over the years to the point where additional space is required to accommodate the child care needs of residents in the Town of Newburgh.

14. Under the ZBA's prior (and, again, respectfully, erroneous) decision, the Petitioner cannot expand the child care facilities on its property to the existing accessory building without seeking and obtaining a use variance.

15. The legal standard for obtaining a use variance is very stringent. It includes, among others, a showing that a reasonable return cannot be obtained upon the property without a use variance and a showing that the difficulty in complying with applicable zoning is not self-created. It is unlikely that the Petitioner can successfully meet the standard required for grant of a use variance.

16. If the Town Board enacts the requested zoning amendment to include Nursery School for Pre-School Children, then the Petitioner will be able to use of the accessory building for housing student/attendee activities.

17. The requested zoning amendment will benefit not only the Petitioner but also all residents of the Town of Newburgh who require quality child care, as it will allow for additional child care locations to be established within the Town.

18. Furthermore, adding "Nursery School For Pre-School Children" to the permitted uses in the "B" District is consistent with the uses currently permitted within the B Zoning District and the Town's Comprehensive Plan.

19. Under the Town Code, the uses permitted in the Town's "B" zoning districts currently consist of:

- one or two-family dwellings,
- membership clubs,
- municipal buildings,
- retail and personal service stores,
- business, professional and research offices,
- eating and drinking places,
- Indoor amusement establishments,
- Motor vehicle service stations, public garages, car washes and rental agencies,
- Convenience stores (with or without gasoline filling stations),
- Hotels and motels,
- Shopping centers,
- Theaters,
- Places of Worship,
- Business parks,
- Public utility structures,
- Affordable housing,
- Senior housing,
- Restaurants,
- Mini-malls, and
- Veterinarian offices.

It is respectfully asserted that the use of Nursery School for Pre-School Children is wholly consistent and compatible with the above-listed uses.

20. The Town's Comprehensive Plan does not appear to speak to the issue of child care facilities. But it does note that "The Town of Newburgh, New York is one of the fastest growing communities in a region experiencing tremendous growth and development"; and a zoning amendment providing opportunities of additional child care facilities would certainly serve that need.

C.). Submittal of Proposed Local Law For Zoning Amendment

21. Annexed hereto as Exhibit "D" is a draft local law by which the proposed zoning amendment may be enacted if the Town Board wishes to do so.

WHEREFORE, the Petitioner respectfully prays that the Town the Board of the
Town of Newburgh enact the proposed zoning amendment.

Dated: Newburgh, New York
November 26, 2019

Building Blocks Child Care Center, Inc.,

BY: Maria Marino, President

10A



TOWN OF NEWBURGH RECREATION DEPARTMENT

311 ROUTE 32, NEWBURGH, NY 12550

Robert J. Petrillo
Commissioner of Parks, Recreation & Conservation

845-564-7815
FAX: 845-564-7827

January 6, 2020

TO: Gil Piaquadio, Supervisor
Town Board Members

FROM: Robert J. Petrillo, Commissioner

DATE: January 6, 2020

RE: Chadwick Lake Park – Concert Series

At this time we are requesting approval to make payments from the T-38 account for the Chadwick Lake Park Concert Series expenses. Expenses will include the cost of the entertainment and refreshments for the five (5) events being held June thru August.

The estimated total cost is approximately \$4,000.

Thank you,

Robert J. Petrillo
Commissioner

2020 – Total \$2050.00 for Bands

June 25th

Sass & Brass - \$400.00

Mike - (845)527-2770

32 Odell Circle

Newburgh NY 12550

July 9th

Hudson Valley Bluegrass Express - \$450.00

Mike Aiese (845) 647-3376

9 Jean St

Ellenville NY 12428

July 23rd

Midnight Slim & LaurieAnne - \$400.00

August 6th

Borrowed Tyme Band - \$350.00

(Classic Rock – Genre) 60's & 70's

Jazz Band

(845) 564-1389

John McDonough

Joanne McDonough

1526 State Route 32

Wallkill NY 12589

August 20th

Fred Zepplin Band - \$450.00

(845)417-1395

Alan Paul

27 Blossom Grove Ct

Highland NY 12528

10B



TOWN OF NEWBURGH RECREATION DEPARTMENT

311 ROUTE 32, NEWBURGH, NY 12550

Robert J. Petrillo
Commissioner of Parks, Recreation & Conservation

845-564-7815
FAX: 845-564-7827

TO: Gil Piaquadio, Supervisor
Town Board Members

CC: Joseph Pedi, Town Clerk

FROM: Robert J. Petrillo, Commissioner

DATE: January 6, 2020

RE: Sealed Bid Request – Chadwick Lake Park Grounds Maintenance

The Recreation Department is requesting the Town Board to establish a sealed bid for 2020 grounds maintenance at Chadwick Lake Park. The request will include bid requests for 2021 and 2022 at the option of the Town Board. A copy of the bid package is also attached.

Regards,

A handwritten signature in black ink, appearing to be "RJP", is written over the word "Regards".

Robert J. Petrillo
Commissioner

**TOWN OF NEWBURGH
SEASONAL GROUNDS MAINTENANCE
SERVICES FOR
CHADWICK LAKE PARK**

The Town of Newburgh, NY, invites bids from qualified vendors to furnish weekly grounds maintenance services at Chadwick Lake Park during the period April 20, 2020 through the week of October 31, 2020. The services will include mowing, string trimming, leaf blowing, mulching and/or removal (when applicable) of the following areas of Chadwick Lake Park: playground, pavilion, roller hockey rink and walkways. The Park must be done weekly, preferably early morning as not to effect Park/camp operations. This bid solicitation additionally includes provision for the submission of bids and options at the Town's election to award contract extensions for 2020, 2021 and 2022. Questions: Call 845-564-7815 for more information.

**REQUEST FOR QUOTES,
SPECIFICATIONS
AND ADDITIONAL TERMS AND CONDITIONS**

Payment for Work Performed

Payment will be made on a monthly basis throughout the life of the contract for services in accordance with the price schedule submitted by the successful bidder. **The monthly invoice must be submitted within 10 days of the month's completion accompanied by the prevailing wage documentation.**

Location

The location requiring service under this contract is Chadwick Lake Park.

(A) The areas within Chadwick Lake Park requiring service are identified as follows:

Starting at the Northwestern end just past the private boat launch where the trail is gated (chained) moving southerly through small picnic area to the boathouse parking lot;

And from the boathouse parking lot along the west shore of the lake in a southerly direction to the cove of the southern tip of the lake;

And on the West side of the boat house parking lot in a southerly direction behind the boathouse along the western property line to the park entrance;

And starting from the southern tip of the lake (cove) on the east side of the lake in a northerly direction between the lake and the main parking lot, past the playground to Pine Point Picnic area, then Easterly on both sides of the playground to the dam spillway on the north and the hockey rink on the south;

And starting from the northern end of the hockey roller rink in a southerly direction on both sides of the rink and large pavilion to the property boundary at Route 300;

And from the Southeastern end of the hockey rink to the southern boundary at Route 300 Easterly including the small ball field to the most easterly boundary bordering the stream behind the amphitheater.

Provide the following service to the above described location:

- Weekly grass cutting. Weather permitting, all sites shall be mowed on a weekly interval, except where stated otherwise, starting the week of April 20, 2020 through the week of October 31, 2020. The Town reserves the right to extend the last day of the week of October 31, 2020 expiration date for one or more additional weeks upon notice to the contractor if grounds maintenance is needed as a result of favorable weather conditions, and the work shall be performed by the contractor at the same weekly rate as bid. All walkways, around trees, playground equipment, fencing and other objects as may be found on each site, shall be string trimmed and blown clean, with every mowing. Extraneous paper or trash, branches and pinecones that may be on the grounds will be removed prior to mowing, and not mowed over.
- Weekly edging of drives, parking areas, sidewalks, curbs, posts and flowerbeds.
- Weekly blowing, mulching and/or collection of leaves in the fall as required.
- Blow clean all walkways, steps, driveways and all other paved or graveled areas of grass clippings, leaves and debris.

In the event of drought or unusual weather conditions, the Town reserves the right to suspend and waive all work. Notice of suspension or waiver shall be given at least twenty-four (24) hours prior to a scheduled service day, provided the contractor has notified the Town in writing in advance of such scheduled day. No monies shall be due to the contractor for a week in which all services are waived or suspended.

TECHNICAL SPECIFICATIONS

- A. The Contractor shall furnish all supervision, labor, material, equipment, tools, and transportation required to perform the services specified herein. The services shall be performed as called for in the technical requirements on weekdays only, excluding Town holidays.
- B. Grasses shall be mowed to a minimum height of two inches in warm weather and one and one-half inches (1 ½") during the rainy season. Grass clippings from mowing shall NOT be caught and removed unless they are too unsightly for the particular location, or else are lying in swaths, which might damage the lawn.
- C. **The Contractor shall not transport or apply any herbicides on Town property without prior approval.**

LABOR PREFERENCE/WAGES

The successful bidder shall employ local labor, insofar as the same may be reasonably available. If this is a public works contract covered by Article 8 of the Labor Law or a building service contract covered by Article 9 thereof, neither Contractor's employees nor the employees of its subcontractors may be required or permitted to work more than the number of hours or days stated in said statutes, except as otherwise provided in the Labor Law and as set forth in prevailing wage and supplement schedules issued by the State Labor Department. Furthermore, if this is a public works contract, Contractor and its subcontractors must pay at least the **prevailing wage rate and pay or provide the prevailing supplements**, including the premium rates for overtime pay, as determined by the State Labor Department in accordance with the Labor Law.

The Town of Newburgh reserves the right without cause or penalty, to terminate the contract award at any time upon thirty (30) days written notice when it has been determined to be in the best interest of the Town. Cancellation does not release the Vendor from its obligation to provide goods or services per the terms of the contract during the notification period.

All terms, conditions and requirements as set forth in Request for Quotation for Grounds Maintenance are acceptable as specified therein.

Yes _____ No _____

If "NO", please provide a detailed description and/or explanation of any deviation in your quotation from the specification detailed in Request for Quotation for Grounds Maintenance at Chadwick Lake Park in the space provided below (if additional space is required continue on your letterhead).

INSURANCE REQUIREMENTS

The successful bidder shall supply and maintain insurance which defends, indemnifies and holds harmless the Town of Newburgh, its officers, employees and agents from and against any and all liability, damage claims, demands, costs, judgments, fees, attorney's fees or loss arising directly out of acts or omissions hereunder by the bidder or third party under the direction or control of the bidder. The successful bidder must furnish the Town with Certificate of Insurance prior to commencement of work. The required coverage shall not be less than the following:

Workers Compensation
Statutory Requirements

NY State Disability
Statutory Requirements

General Liability
\$2,000,000

Automobile Liability
\$1,000,000

"Contractual Liability"
Must be printed on Certificate

**INSURANCE CERTIFICATES SHALL NAME THE TOWN OF NEWBURGH,
1496 ROUTE 300, NEWBURGH, NY 12550, AS AN ADDITIONAL INSURED
PARTY AND SHALL STATE THAT ALL COVERAGE SHALL BE PRIMARY
TO ANY OTHER INSURANCE COVERAGE HELD BY THE TOWN.**

FORM A

Bid for Seasonal Grounds Maintenance for Chadwick Lake Park for 2020

Please indicate your bid for the specified work as detailed herein the year as follows:

SEASONAL GROUNDS MAINTENANCE SERVICES COMMENCING THE LAST WEEK OF APRIL 20, 2020 AND ENDING THE LAST WEEK OF OCTOBER 31, 2020 OR SUCH EXTENDED WEEK(S) AS THE TOWN NOTIFIES THE SUCCESSFUL BIDDER.

Please quote a weekly price for services as specified herein.

A) CHADWICK LAKE PARK

2020 Weekly Price: \$ _____ per week

2021 Weekly Price: \$ _____ per week (at the option of the Town)

2022 Weekly Price: \$ _____ per week (at the option of the Town)

As an authorized representative of the identified company, I accept all the terms and conditions identified in Request for Bids for Seasonal Grounds Maintenance Services for Chadwick Lake Park at the price herein quoted, the services as proposed on this bid.

Company Name and Address

By: _____, an authorized representative
Signature

Date: _____

Print Name & Title _____

Email Address: _____

Phone Number: _____

Fax Number: _____

NO BID PROPOSAL WILL BE ACCEPTED UNLESS THE SAME IS SIGNED.

REFERENCES TO BE SUPPLIED UPON REQUEST.

10C



TOWN OF NEWBURGH RECREATION DEPARTMENT

311 ROUTE 32, NEWBURGH, NY 12550

Robert J. Petrillo
Commissioner of Parks, Recreation & Conservation

845-564-7815
FAX: 845-564-7827

TO: Gil Piaquadio, Supervisor
Town Board Members

CC: Joseph Pedi, Town Clerk

FROM: Robert J. Petrillo, Commissioner

DATE: January 3, 2020

RE: Sealed Bus Bid Request

The Recreation Department is requesting the Town Board to establish a sealed bid for 2020 busing. Senior citizen, youth/adult and summer camp trips are attached with dates, times and destinations. A copy of the bid package is also attached.

Regards,

Robert J. Petrillo
Commissioner

Bus Trips - Town of Newburgh Recreation - 2020
49 or 55 passanger Motor Coach with lavatory and DVD player

Item #	Date of Trip	Destination (All are round Trip)	Depart Trip	Approx. Return Time	# of Buses Needed	Price per 38 pass.	Price per 55 pass.
1	3/21/2020	MGM Casino - Springfield MA	9:00am RC	7:00pm RC	1		
2	4/1/2020	Hanover Manor - East Hanover NJ	9:00am CLP	6:30pm CLP	1		
3	4/18/2020	Peddler's Village - Lahaska PA	8:30am RC	6:30pm RC	1		
4	5/16/2020	Penn's Peak - Jim Thorpe PA	9:00am CLP	6:00pm CLP	1		
5	5/21/2020	Hunterdon Hills Playhouse - Hampton NJ	9:15am CLP	5:30pm CLP	1		
6	6/17/2020	Westchester Broadway Theatre - Elmsford NY	9:30am CLP	5:30pm CLP	1		
7	TBA	Yankee Stadium - Bronx NY	4:00pm RC	12:00am RC	1		
8	7/8/2020	Forestburgh Playhouse - Forestburgh NY	10:45am CLP	6:00pm CLP	1		
9	8/1/2020	Dorney Park -Allentown PA	8:00am RC	9:00pm RC	1		
10	8/5/2020	Westchester Broadway Theatre - Elmsford NY	9:30am CLP	5:30pm CLP	1		
11	8/19/2020	Casa Bianca - Oakridge NJ	9:30am CLP	5:00pm CLP	1		
12	9/12/2020	Turtle Back Zoo - Essex County NJ	9:00am RC	5:00pm RC	1		
13	9/25/2020	Brownstone - Paterson NJ	9:00am CLP	5:30pm CLP	1		
14	10/14/2020	Royal Manor -Garfield NJ	9:30am CLP	5:00pm CLP	1		
15	10/17/2020	Mohegan Sun @ Poconos -Wilkes Barre PA	9:00am RC	6:30pm RC	1		
16	10/19/2020	Aqua Turf - Plantsville CT	9:00am CLP	5:30pm CLP	1		
17	12/5/2020	Forest Park - Springfield MA	2:00pm RC	9:45pm RC	1		
18	TBA	Radio City - New York NY	9:00am RC	6:30pm RC	1		
19	TBA	Times Union Center - Albany NY	9:00am RC	5:00pm RC	1		
20	1/30/2021	Mohegan Sun Casino - Uncasville CT	9:00am RC	9:00pm RC	1		
21	2/27/2021	Wind Creek - Bethlehem PA	9:00am RC	7:00pm RC	1		

Please note:

Trips are subject to cancellation due to lack of enrollment or adverse weather conditions up to 48 hrs before trip.

This list is subject to increase as special events, tickets and shows may come up during the course of the year.

CLP = Chadwick Lake Park (1702 Route 300 Newburgh NY)

RC = Recreation Center (311 Route 32 Town of Newburgh)

Bus Company:

Address:

Contact person:

Phone #:

Town of Newburgh Recreation -- Bus Schedule-Camp Chadwick 2020

Pricing for School Buses (44 adult, 66 children)

All are Round Trips - From Chadwick Lake Park (1702 Route 300)

Item #	Date	Destination	Depart Time	Approx. Return Time	# of Buses Needed	Cost Per Bus
1	6/30/2020	Splashdown Fishkill NY	9:15am	5:00pm	5	
2	7/2/2020	Tarsio Bowling Lanes Newburgh NY	10:30am	2:30pm	5	
3	7/8/2020	Howe Caverns Howes Cave NY	8:00am	5:30pm	5	
4	7/15/2020	Lake Compounce Bristol CT	8:30am	7:00pm	5	
5	7/22/2020	Brownstone Portland CT	8:00am	7:00pm	5	
6	7/29/2020	Great Escape Lake George NY	8:00am	7:30pm	5	
7	8/5/2020	Mt Creek Vernon NJ	9:30am	5:30pm	5	
8	8/12/2020	Camelback Beach Tannersville PA	8:00am	7:30pm	5	
9	8/19/2020	Kruckers Pomona NY	9:00am	4:30pm	2	
10	TBA	Show Time Cinema Newburgh NY	11:00am	2:00pm	5	

Please note:

Trips are subject to cancellation due to lack of enrollment or adverse weather conditions up to 48 hrs before
This list is subject to increase as special events, tickets and shows may come up during the course of the year.

CLP = Chadwick Lake Park (1700 Route 300 Newburgh NY)

RC = Recreation Center (311 Route 32 Town of Newburgh)

Bus Company: _____

Address: _____

Contact Person: _____

Phone #: _____

TOWN OF NEWBURGH
EQUIPMENT SPECIFICATIONS
CHARTER BUS SERVICE
FOR RECREATION DEPARTMENT TRIP PROGRAM

1. All buses must be model year **2014** or newer and equipped with anti-lock brakes.
2. The exterior of the bus must be well painted and clean with no signs of damage.
3. The interior of the bus must be clean with upholstery and flooring in good condition.
4. All on-board restroom facilities must be completely functioning and clean. Restrooms must be serviced as often as necessary to avoid offensive odors in the rear portion of the bus.
5. Air-conditioning and heating must be in excellent working order.
6. All buses provided for scheduled trips **MUST** be in good condition and meet all Department of Transportation, Federal Highway Administration rules, regulations and guidelines. All maintenance records for buses to be provided must be available to the Town of Newburgh for inspection.
7. If an inspection of your bus or buses is requested by the Town of Newburgh, the inspection should take place within ten (10) working days of request. The records for the bus or buses **MUST BE WITH THE BUS OR BUSES AT THE TIME OF THE INSPECTION**. Failure to provide these records will eliminate your bid from consideration.
8. Vendor will be responsible for compliance with all DOT/FHWA regulations with regard to their service for The Town of Newburgh bus trip. If more than one (1) driver per bus is needed based on the bid itinerary, it is the vendor's responsibility to determine this need.
9. Any backup or replacement buses used must meet the same criteria as originally required in the bid specifications.
10. Buses shall have a capacity of at least 49 passengers plus driver, except, if the trip list specifies a larger passenger capacity, the bus provided must have at least that capacity.

Bidders shall specify the equipment proposed to be used in fulfilling the contract. Sufficient information to identify and assess the equipment shall be provided. As a minimum, provide the number of units, make, model, age, mileage, condition, style and capacity of the equipment that is proposed to be provided.

TOWN OF NEWBURGH
INSURANCE SPECIFICATIONS
CHARTER BUS SERVICE
FOR RECREATION DEPARTMENT TRIP PROGRAM

The successful bidder(s) shall supply and maintain insurance which defends, indemnifies and holds harmless the Town of Newburgh, its officers, employees and agents from and against any and all liability, damage claims, demands, costs, judgments, fees, attorney's fees or loss arising directly out of acts or omissions hereunder by the contractor or third party under the direction or control of the contractor.

The required insurance coverage shall not be less than the following:

Workers Compensation:	Statuary Requirements
NY State Disability:	Statuary Requirements
General Liability:	\$3,000,000
Automobile Liability:	\$2,000,000

IF YOU DO NOT HAVE A CURRENT CERTIFICATE OF LIABILITY INSURANCE ON FILE WITH THE TOWN OF NEWBURGH TOWN CLERK, IT MUST BE SUBMITTED WITHIN FIVE (5) WORKING DAYS OF REQUEST, OR YOUR BID(S) WILL BE ELIMINATED FROM CONSIDERATION IN THE BID AWARD(S).

The successful bidder(s) must furnish the Town with a Certificate of Insurance prior to commencement of work showing coverage in effect. If the certificate will expire before the trip(s) will be taken, a new certificate must be received fifteen (15) days prior to the expiration of your current policy. Insurance certificates, in addition to proof of coverage, shall contain the standard Accord statement pertaining to written notification to the Town of Newburgh in the event of cancellation, with a thirty (30) day notification period.

INSURANCE CERTIFICATES SHALL NAME THE TOWN OF NEWBURGH AS AN ADDITIONAL INSURED PARTY AND SHALL STATE THAT ALL COVERAGE SHALL BE PRIMARY TO ANY OTHER INSURANCE COVERAGE HELD BY THE TOWN WITH RESPECT TO ACTS OR OMISSIONS OF THE NAMED INSURED.

A fax copy of the certificate may be sent to the Town Clerk for purposes of the bid, but the original certificate of insurance must be received by the Town Clerk at least five (5) days prior to the scheduled trip date.

The Town reserves the right to terminate the contract if the vendor fails to keep these policies in force for the above amounts or for the duration of the contract period.

TOWN OF NEWBURGH
GENERAL SPECIFICATIONS, TERMS AND CONDITIONS
CHARTER BUS SERVICE
FOR RECREATION DEPARTMENT TRIP PROGRAM

Terms and Conditions

1. Bids are required to be submitted and will be awarded on an individual trip basis. If the vendor defaults in the performance of any trip, however, the Town reserves the right to terminate the bid award(s) to that vendor for all remaining awarded trips and to award the trip to the next lowest responsible bidder(s) for those trips.
2. The prices quoted herein, if accepted, will be considered guaranteed, unadjustable prices for the terms stated herein, unless otherwise so identified in other sections of this bid request.
3. The terms of the agreement awarded from this bid will commence on date of award and expire December 31, 2020, unless otherwise specified in this Request for Proposal/Quotation.
4. This bid agreement shall override any previous agreements for this item(s), except as otherwise provided herein.
5. The Town of Newburgh reserves the right to reject any and all bids if deemed in the best interest of the Town to do so. The Town shall have the authority to award orders, contracts, or services to the bidder(s) best meeting the specifications and conditions as judged solely by the Town.
6. All services shall be performed as described in this bid and shall comply in all respects with applicable Federal, State, County and Town Statutes and Codes.
7. The Town Board shall determine whether bid exceptions are minor in nature or represent a serious departure from the purpose and intent of the specifications and whether or not the best interests of the Town will be promoted by waiving original requirements and accepting exceptions.
8. The Town of Newburgh assumes no responsibility and no liability for costs incurred by bidders prior to the issuance of an agreement, contract or purchase order.
9. Vendors who submit a Proposal(s) in response to this bid may be required to give an oral presentation of their Proposal(s). The purpose of such presentation is to provide an opportunity for the vendor to clarify or elaborate on their bid.
10. Bids are solicited only from competent, experienced and financially qualified vendors who meet all the qualifications and or specifications of this bid document as determined solely by the Town of Newburgh.
11. The Town reserves the right to utilize transportation service from the successful bidder(s) for any and all programs and trips listed herein and to eliminate any program or trip location upon 48 hours notice before coach bus trips and 24 hours notice before school bus trips, at its discretion.
12. The Town reserves the right to request transportation service for additional programs and trips that are anticipated but cannot be identified at this time. Additional services needed shall be negotiated on an as needed basis based on trip location, time and service availability. The Town will solicit prices in accordance with its purchase policy guidelines.

Payment for Work Performed

Payment will be made on the completion of each trip for service in accordance with the price schedule submitted by the successful bidder(s). The Town does not guarantee the actual number of each item that will actually be required. The Town shall be held harmless by the successful bidder(s) for lost revenue, profit or any other hardship due to the actual services procured during the award period.

Bidder Qualification Requirements

1. Bids will only be accepted from thoroughly competent, experienced and financially qualified transportation service firms as determined solely by the Town of Newburgh. The bidder must demonstrate, upon request, that is had five (5) years immediate acceptable prior experience in providing such services. The Town will be the sole judge as to any bidder's fulfillment of the stated requirements and qualifications.
2. All bidders must have a current and valid transportation business registration, licenses and permits as required by law at the time of bid submission and must remain valid for the entirety of the contract period.
3. All bidders and their commercial licensed drivers must hold a current and valid New York State Drivers License for providing this service.
4. All bidders shall be required to execute and submit a non-collusion statement with their bids in accordance with New York State law.
5. All bidders must supply at least three (3) references, including contact persons name, address and phone number for which they have provided similar services.

Firm
 Description
 Contact Person
 Phone #

6. The successful bidder must comply with New York State Labor Laws.

It is mutually understood that the successful vendor shall not assign, transfer, convey, sublet or otherwise dispose of his contract or his right, title or interest therein, or his power to execute such contract, to any other person, firm or corporation, without the previous written consent of the Town of Newburgh. Failure to comply with this requirement will result in the cancellation of this contract.

Cancellation/Termination

Any violation of the terms, conditions, requirements and/or non-performance of the contract shall result in immediate cancellation. The bid award may be immediately cancelled upon written notice for cause, including, but not limited to, the following:

- (1) failure to provide personnel or equipment to the Town's satisfaction or failure in any other way deliver to perform or provide service within the terms of contract;
- (2) failure of the equipment or service to meet specifications;
- (3) default by vendor in connection with any other prior Town of Newburgh trip;
- (4) misrepresentation by the vendor;
- (5) fraud, collusion, conspiracy, or other unlawful means of obtaining any contract with the Town;
- (6) conflict of contract provisions with constitutional or statutory provisions of the laws of the State of New York or federal law; and
- (7) any other breach of contract.

The Town of Newburgh reserves the right without cause or penalty, to terminate the contract award at any time upon thirty (30) days written notice, when it has been determined to be in the best interest of the Town. Cancellation does not release the Vendor from its obligation to provide goods or services per the terms of the contract during the notification period.

As an authorized representative of the identified company, I accept all the terms and conditions identified in Request for Proposal.

Company Name and Address

By: _____, an authorized representative
Signature

Dated: _____

Print Name & Title

Email Address: _____

Phone Number: _____

Fax Number: _____

CERTIFICATE OF NON-COLLUSION

By submission of this bid, each bidder and each person signing on behalf of any bidder certifies, and in the case of a joint bid each party thereto certifies as to its own organization, under penalty of perjury, that to the best of knowledge and belief: (1) The prices in this bid have been arrived at independently without collusion, consultation, communication, or agreement, for the purpose of restricting competition, as to any matter relating to such prices with any other bidder or with any competitor; (2) Unless otherwise required by law, the prices which have been quoted in this bid have not been knowingly disclosed by the bidder and will not knowingly be disclosed by the bidder prior to opening, directly or indirectly, to any other bidder or to any competitor; and (3) No attempt has been made or will be made by the bidder to induce any other person, partnership or corporation to submit or not to submit a bid for the purpose of restricting competition.

Name of Bidder

Signature of Authorized Representative

Title

Name of Authorized Representative (Printed)

Date

NOTICE TO BIDDERS
31 BUS TRIPS
DURING CALENDAR YEAR
2020
RECREATION DEPARTMENT
TOWN OF NEWBURGH,
NEW YORK

NOTICE IS HEREBY GIVEN that sealed bids will be accepted on behalf of the Town of Newburgh Town Board by the Town Clerk at 1496 Route 300, Newburgh, NY, 12550 until 10:30 a.m. prevailing time on _____ 2020, at which time bids will be publicly opened and read aloud in the meeting room of Town Hall.

BIDS SHALL BE SUBMITTED IN SEALED ENVELOPES to the above address given and shall bear on the face thereof the name and address of the bidder and the item being bid.

BIDS SHALL BE ON FORMS PROVIDED BY THE TOWN CLERK. Forms and detailed specifications are available to interested bidders between the hours of 8:30 a.m. and 4:30 p.m., Monday through Friday at the Town Clerk's Office.

BIDS are for 21 charter bus trips to various locations, the first of which will take place on March 21, 2020 and the last of which is scheduled for February 27, 2021. The buses shall have a capacity of at least 49 passengers plus driver and must be equipped with lavatory facilities. Also included for BIDS are 10 school bus trips to various locations, first of which will take place on July 1, 2020 and the last of which is scheduled for August 19, 2020.

BIDDERS will be requested to submit individual bids per trip. The Town reserves the right to award trips individually for each trip.

TRIPS to be bid upon are subject to cancellation due to lack of enrollment or adverse weather conditions up to 48 hours before the trip for coach bus trips and 24 hours for school bus trips. The list of trips is subject to increase as special events, tickets and shows may come up during the course of the year. At that time, the Recreation Department shall solicit prices in accordance with the Town's purchase policy.

THE LIST OF TRIPS is available as a part of the specifications available from the Town Clerk's office.

BY ORDER OF THE TOWN BOARD
OF THE TOWN OF NEWBURGH
ANDREW J. ZARUTSKIE,
TOWN CLERK

10D



TOWN OF NEWBURGH RECREATION DEPARTMENT

311 ROUTE 32, NEWBURGH, NY 12550

Robert J. Petrillo
Commissioner of Parks, Recreation & Conservation

845-564-7815
FAX: 845-564-7827

TO: Gil Piaquadio, Supervisor
Town Board Members

FROM: Robert J. Petrillo, Commissioner

DATE: January 3, 2020

RE: 2020 Program Brochure

The Recreation Department has received two quotes for the printing of the 2020 Annual Program Brochure. For your reference, attached is the list of vendors from whom quotes were requested.

At this time, I am requesting your approval to accept the quote from ColorPage at the quoted price of \$5,795. ColorPage was the lowest quote in 2019 as well.

Thank you for your consideration.

Regards,

Robert J. Petrillo
Commissioner

Attachments



TOWN OF NEWBURGH RECREATION DEPARTMENT

311 ROUTE 32, NEWBURGH, NY 12550

Attn: Donna

845-564-7815

FAX: 845-564-7827

November 25, 2019

TO: Potential Bidders
FROM: Robert J. Petrillo, Commissioner
RE: Price Quote for 2020 Town of Newburgh Recreation Department Program Brochure

Specifications including quantity to be delivered to the Recreation Department are as follows:

Quantity: 9,200

Packaging: Bulk Carton

Delivery to: Town of Newburgh Recreation Department

Cover Stock: 80 # Gloss book cover is 4/2 full color with full bleed all sides

Text Stock: 32 inside pages on 60 # white, 2 color throughout

Bindery/size: Stapled and 3 sides trimmed to 8.5 x 11 finished size

Design/layout: Supplied in Adobe InDesign CS5 version
On-site consultation and pick up of file
Complete proof for approval prior to printing

Approximate delivery time from final approval: 5-7 working days

Price quote for consultation, file and proof: NO COST = 0

Price quote for printing and bindery: \$5795⁰⁰ INCLUDES 1 proof & bindery

Total amount of price quote: \$5995⁰⁰ INCLUDES delivery

Name of Company: Color Page

Address of Company: 81 TEN BROECK AVE.
KINGSTON, NY 12401

Name of Contact Person: Frank Campagna

Phone Number: 845-331-7581 or Cell 845-389-3081

PLEASE SUBMIT QUOTE BY DECEMBER 30, 2019

Thank you!

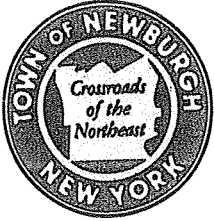

TOWN OF NEWBURGH RECREATION DEPARTMENT

311 ROUTE 32, NEWBURGH, NY 12550

845-564-7815

FAX: 845-564-7827

November 25, 2019

TO: Potential Bidders
FROM: Robert J. Petrillo, Commissioner
RE: Price Quote for 2020 Town of Newburgh Recreation
Department Program Brochure

Specifications including quantity to be delivered to the Recreation Department are as follows:

Quantity: 9,200

Packaging: Bulk Carton

Delivery to: Town of Newburgh Recreation Department

Cover Stock: 80 # Gloss book cover is 4/2 full color with full bleed all sides

Text Stock: 32 inside pages on 60 # white, 2 color throughout

Bindery/size: Stapled and 3 sides trimmed to 8.5 x 11 finished size

Design/layout: Supplied in Adobe InDesign CS5 version
On-site consultation and pick up of file
Complete proof for approval prior to printing

Approximate delivery time from final approval: 10 work days

Price quote for consultation, file and proof: \$ 540⁰⁰

Price quote for printing and bindery: \$ 5,754⁰⁰

Total amount of price quote: \$ 6,294⁰⁰

Name of Company: MAAR PRINTING SERVICE

Address of Company: 49 CATALY ST

Pough NY 12601

Name of Contact Person: Tony Serino

Phone Number: 845-454-6860

PLEASE SUBMIT QUOTE BY DECEMBER 30, 2019

Maar Printing
49 Oakley Street
Poughkeepsie, NY 12601

The Print Shop
623 Broadway
Newburgh, NY 12550

Printing Plus
96 Turner Road
Central Valley, NY 10917

Proforma K Print Solutions
15 Goshen Avenue
Washingtonville, NY 10992

Orange County Post Printing
36 Meriline Avenue
New Windsor, NY 12553

ColorPage Marketing & Publishing
81 Ten Broeck Avenue
Kingston, NY 12401
ATTN: Jeffrey Conciatori

10E



TOWN OF NEWBURGH RECREATION DEPARTMENT

311 ROUTE 32, NEWBURGH, NY 12550

Robert J. Petrillo
Commissioner of Parks, Recreation & Conservation

845-564-7815
FAX: 845-564-7827

TO: Gil Piaquadio, Supervisor
Town Board Members

FROM: Robert J. Petrillo, Commissioner

DATE: January 3, 2020

RE: 2020 Community Day Fireworks

The Recreation Department is requesting the Board's approval to exercise their option to select Fireworks Extravaganza to present the 2020 Community Day fireworks at the manual price of \$11,500.

Fireworks Extravaganza represented the only quote received from the bid solicitation in 2018. Bid details attached.

Regards,

A handwritten signature in black ink, appearing to be "R. Petrillo", written in a cursive style.

Robert J. Petrillo
Commissioner

January 24, 2018

Community Fireworks Bid
 Wednesday, February 28, 2018 at 10:00 am

Package #	Company	Address	Comments	Name/email	Telephone	Bid		Actual Bid
						Received		
1	retained by Town							
2	Young Explosive Corporation	2165 New Michigan Road, Canadadua, NY 14424	sent by US Mail 1/25/2018	Bob Kesel	none given			
3	Bay Fireworks	999 South Oyster Bay Road; Suite 111 Bethpage, NY 11714	sent by email: 1/26/2018	Charlie Rappa	516-597-5500			
4	Fireworks Extravaganza	174 Route 17N Suite 213; Rochelle Park, NJ 07662	sent by email and fax 1/30/2018	Brian Hollenback	800-765-2264 fax: 206- 202-1544	Bid Recv'd 2/22		Manual Fire: 2018 - \$10,500; 2019 - \$11,000; 2020 - \$11,500 Computer Fire: 2018 - \$12,600; 2019 - \$13,200; 2020 - \$13,800
5	Santore Fireworks	PO Box 687; Stillwater, NY 12170	sent by email 2/9/2018	Jeff Ward	518-470-0165			
6	Prime Vendor	4622 Cedar Ave; Wilmington, NC 28403	sent by email 2/9/2018	Veronica Bryan	800-745-9554			
7	Legion Fireworks	10 Legion Lane; Wappinger Falls, NY	sent by email 2/13/2018	Deanna	845-831-8328			



TOWN OF NEWBURGH

1496 Route 300, Newburgh, New York 12550

PERSONNEL DEPT.

PH: 845-566-7785
Fax: 845-564-2170

To: Gilbert Piaquadio, Supervisor ✓
Town Board Members

From: Charlene M. Black, Personnel Director

Date: January 13, 2020

Re: Part time Chauffeur

Mr. Petrillo has requested approval to hire Michael Ponesse as a part time chauffeur, due to the declination of Mr. Marcelly. The applicant's hiring is contingent on your approval and the completion of his fingerprints, paperwork, drug/alcohol screening and physical. A start date of on or after February 10, 2020 is anticipated. Thank you in advance.



TOWN OF NEWBURGH RECREATION DEPARTMENT

311 ROUTE 32, NEWBURGH, NY 12550

Robert J. Petrillo
Commissioner of Parks, Recreation & Conservation

845-564-7815
FAX: 845-564-7827

TO: Gil Piaquadio, Supervisor
Town Board Members

CC: Charlene Black, Personnel

FROM: Robert J. Petrillo, Commissioner

DATE: January 9, 2020

RE: Hire Part Time Chauffeur

At this time, I would like to request approval to hire Michael Ponesse for the position of Part Time Chauffeur in the Recreation Department. Mr. Ponesse will be hired at the rate of \$18.00/hour. The salary for this position is in the 2020 budget.

Start date for this position will be on or after February 10th. Thank you for your consideration.

Regards,

Robert J. Petrillo
Commissioner

TOWN OF NEWBURGH

EMPLOYMENT REQUEST FORM

To: Personnel Department

NAME OF CANDIDATE: MICHAEL PONESSE

DEPARTMENT: RECREATION

TITLE OF POSITION: CHAUFFEUR

FULL TIME OR PART TIME: PART TIME

HOURLY RATE: \$18.00

IS POSITION FUNDED IN CURRENT BUDGET: YES OR NO

FUND APPROPRIATION NUMBER: 6773.5100

PROPOSED HIRE DATE: Feb. 10, 2020

NOTE: CANDIDATE CANNOT BEGIN WORK WITHOUT PRE-EMPLOYMENT PHYSICAL AND COMPLETION OF ALL REQUIRED PAPERWORK.

DEPARTMENT HEAD SIGNATURE

1/10/20
DATE

ORIGINAL APPLICATION SHOULD BE ON FILE IN THE PERSONNEL
DEPARTMENT

COPY TO ACCOUNTING DEPARTMENT
11/15/2010



TOWN OF NEWBURGH

1496 Route 300, Newburgh, New York 12550

PERSONNEL DEPT.

To: Supervisor Piaquadio ✓
Town Board

PH: 845-566-7785
Fax: 845-564-2170

From: Charlene M Black, Personnel

Date: December 30, 2019

Re: Wastewater Maintenance Worker

On Friday December 20, 2019, Jeff Guido, Paul Ruggiero, Liaison and myself interviewed the two candidates for the position of Wastewater Maintenance Worker. At this time Mr. Guido would like to offer the position to Daniel Tartter effective February 3, 2020. The salary is per the CSEA contract, which is a Grade 15, \$23.1571 per hour. No paperwork besides a new application is needed since he is already a full time employee. Thank you.

TOWN OF NEWBURGH

EMPLOYMENT REQUEST FORM

To: Personnel Department

NAME OF CANDIDATE: Daniel TarHer
DEPARTMENT: Sewer
TITLE OF POSITION: Wastewater Maintenance Worker
FULL TIME OR PART TIME: Full time
HOURLY RATE: \$ 22.48

IS POSITION FUNDED IN CURRENT BUDGET: YES OR NO

FUND APPROPRIATION NUMBER: G5010.8130.5100

PROPOSED HIRE DATE: 2/3/2020

NOTE: CANDIDATE CANNOT BEGIN WORK WITHOUT PRE-EMPLOYMENT PHYSICAL AND COMPLETION OF ALL REQUIRED PAPERWORK.

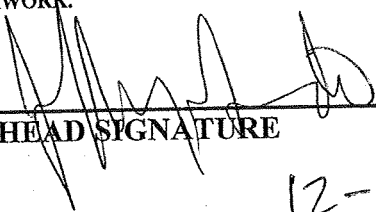
DEPARTMENT HEAD SIGNATURE

12-20-19
DATE

ORIGINAL APPLICATION SHOULD BE ON FILE IN THE PERSONNEL
DEPARTMENT

COPY TO ACCOUNTING DEPARTMENT

11B



TOWN OF NEWBURGH

**1496 Route 300
NEWBURGH, NEW YORK 12550
(845) 564-4552**

Date: 1/11/2020

Is the budget adjustment under \$5,000? Yes: _____ No: X

If yes, Please give Gil a copy to sign and deliver to the Accounting Office.

If no, Please have the board approve at the next available board meeting.

Reason why the budget transfer is needed: Cover shortfall for Sludge Hauling, and chemicals at CLFP

From:	Account Number:	<u>8330.4002.5459</u>	Amount:	<u>\$ (3,000.00)</u>
	Account Description:	<u>Chemicals - DAT</u>	Amount:	_____
From:	Account Number:	<u>8330.4001.5481</u>	Amount:	<u>\$ (4,000.00)</u>
	Account Description:	<u>Utilities, Fuel CLFP</u>	Amount:	_____
From:	Account Number:	<u>8330.4001.5466</u>	Amount:	<u>\$ (5,000.00)</u>
	Account Description:	<u>Operating Supplies - CLFP</u>	Amount:	_____
From:	Account Number:	<u>7330.4001.5470</u>	Amount:	<u>\$ (4,000.00)</u>
	Account Description:	<u>Testing CL</u>	Amount:	_____
From:	Account Number:	_____	Amount:	_____
	Account Description:	_____	Amount:	_____
=====			SubTotal	<u>\$ (16,000.00)</u>
To:	Account Number:	<u>8330.4001.5459</u>	Amount:	<u>\$ 6,000.00</u>
	Account Description:	<u>Chemicals CLFP</u>	Amount:	_____
To:	Account Number:	<u>8330.4001.5457</u>	Amount:	<u>\$ 10,000.00</u>
	Account Description:	<u>Sludge Hauling - CLFP</u>	Amount:	_____
To:	Account Number:	_____	Amount:	_____
	Account Description:	_____	Amount:	_____
=====			SubTotal	<u>\$ 16,000.00</u>
Please note: The total of from/to should be equal.			Total	<u>0.0</u>
=====				

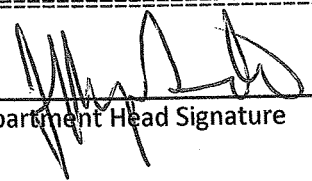

Department Head Signature

Gil Piaquadio, Town Supervisor

KALA

Karen Arent Landscape Architect

12B

Memorandum

To: Supervisor Gil Piaquadio and the Town of Newburgh Board

From: Karen Arent, Landscape Architect

Date: December 24, 2019

Subject: McDonald's Partial bond release Recommendation

Town Project Number: 2017-26

Cc: Chairman John Ewasutyn and the Town of Newburgh Planning Board, Alex Lomei, Engineer, Gerald Canfield, Town of Newburgh Code Compliance Supervisor

COMMENTS:

The landscape looks great. All plants were installed in accordance with the approved landscape plans. Stone walls were installed in accordance with plans.

I recommend releasing one half of the bond amount, \$32,665. The total amount of the bond is \$65,330. The remainder of the bond should be held for two years to ensure plants survive. One more quarter of the bond can be released in September 2020 if the landscape inspection reveals that plants are in good condition and few replacements are necessary. The remainder of the bond can be released in September 2021 if all plants are in good condition and few replacements are required.

13A



HIGHWAY DEPARTMENT

90 GARDNERTOWN ROAD
NEWBURGH, NEW YORK 12550

TELEPHONE 845-561-2177
FAX 845-561-8987

MARK HALL
HIGHWAY SUPERINTENDENT

TO: Gil Piaquadio, Supervisor, & Town Board Members

FROM: Mark Hall, Highway Superintendent *MH*

DATE: January 9, 2020

RE: Transfer Request

I would like to request the following budget transfers could you please put this on the agenda for the next meeting:

FROM:	TO:	AMOUNT:
D.5130.5452 Machinery/Vehicle Contract Repairs	D.5130.5451 Machinery/Vehicle Parts	\$10,000.00

This is for a 2019 adjustment

If you have any questions please feel free to contact me. Thank you.

MH:ch
cc: R. Clum, Accounting

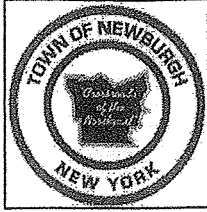

Town of Newburgh
 1496 Route 300
 Newburgh, New York 12550
 (845) 564-4552

Date: 1-9-20

Is the budget adjustment under \$5,000? Yes _____ No:

If yes: Please give Gil a copy to sign and deliver to the Accounting Office.

If no: Please have the board approve at the next available board meeting.

Reason why the budget transfer is needed MORE PARTS WERE NEEDED
THAN EXPECTED

From: Account Number: D.5130.5452 Amount: \$10,000⁰⁰/_{xx}
 Account Description: Machinery Amount: _____
Vehicle Contract Repairs

From: Account Number: _____ Amount: _____
 Account Description: _____ Amount: _____

To: Account Number: D.5130.5451 Amount: \$10,000⁰⁰/_{xx}
 Account Description: Machinery Amount: _____
Vehicle Parts

To: Account Number: _____ Amount: _____
 Account Description: _____ Amount: _____

Please note: The total of the from and to should equal.



 Department Head Signature

 Gil Piaquadio, Town Supervisor



TOWN OF NEWBURGH

1496 Route 300, Newburgh, New York 12550

13B

PERSONNEL DEPT.

PH: 845-566-7785
Fax: 845-564-2170

To: Gilbert Piaquadio, Town Supervisor ✓
Town Council

From: Charlene M Black, Personnel

Date: January 2, 2020

Re: Part Time Laborer

Upon your approval, Nicholas Ponesse has been a seasonal laborer for us in the past and has been offered a part time laborer position. Employment will be contingent on completing the necessary paperwork for part time employment and physical. Fingerprints and Drug/Alcohol testing has been completed. The salary for a part time laborer is \$12.50 per hour. Start date on or after February 3, 2020.



HIGHWAY DEPARTMENT

90 GARDNERTOWN ROAD
NEWBURGH, NEW YORK 12550

TELEPHONE 845-561-2177
FAX 845-561-8987

MARK HALL
HIGHWAY SUPERINTENDENT

TO: Charlene Black, Personnel Department

FROM: Mark Hall, Highway Superintendent 

DATE: January 3, 2020

RE: Part Time Employee

I am requesting that Nicholas Ponesse be hired for the Town of Newburgh Highway Department. The title will be Part time laborer and the rate of pay will be \$12.50 per hour, with a tentative start date on or after February 3, 2020. Thank you.

MH:ch

TOWN OF NEWBURGH

EMPLOYMENT REQUEST FORM

To: Personnel Department

NAME OF CANDIDATE: Nicholas PONESSE

DEPARTMENT: HIGHWAY

TITLE OF POSITION: LABORER

FULL TIME OR PART TIME: PART TIME

HOURLY RATE: \$12.50

IS POSITION FUNDED IN CURRENT BUDGET: YES OR NO

FUND APPROPRIATION NUMBER: 5110.100

PROPOSED HIRE DATE: ON OR AFTER FEBRUARY 3, 2020

NOTE: CANDIDATE CANNOT BEGIN WORK WITHOUT PRE-EMPLOYMENT PHYSICAL AND COMPLETION OF ALL REQUIRED PAPERWORK.

DEPARTMENT HEAD SIGNATURE

1/3/20
DATE

ORIGINAL APPLICATION SHOULD BE ON FILE IN THE PERSONNEL
DEPARTMENT

COPY TO ACCOUNTING DEPARTMENT
5-22-2017

13C



HIGHWAY DEPARTMENT

90 GARDNERTOWN ROAD
NEWBURGH, NEW YORK 12550

TELEPHONE 845-561-2177
FAX 845-561-8987

MARK HALL
HIGHWAY SUPERINTENDENT

TO: Gil Piaquadio, Supervisor & Town Board Members
FROM: Mark Hall, Highway Superintendent *MH*
DATE: January 21, 2020
RE: Tandem Plow Truck

I would like to be put on the agenda, to purchase a Tandem Plow Truck from Beam Mack Sales Service, Inc. for the cost of \$144,562.05. We will be piggy backing off the Onondaga County Heavy Truck Class 8 Statewide Contract # 8996. The funds are available and will be taken from D.5130.5200 Machinery Equipment/Other Capital.

If you have any questions please feel free to call me. Thanking you in advance.

MH/ch
cc: Ron Clum, Accounting

Beam Mack Sales Service, Inc.

6260 E Molloy Rd.

E Syracuse, NY 13057

ONONDAGA COUNTY HEAVY TRUCK CLASS 8 STATEWIDE

CONTRACT

8996

GRANITE 42 FR PRICING SHEET ONONDAGA

CUSTOMER: Town of Newburgh

CHASSIS QUOTED: Granite 64FR 455HP / Allison 4500RDS

	CHASSIS BASE PRICE	CHASSIS OPTIONS	TOTAL
MACK GRANITE. 2021 Model Year	\$170,203.00		
DISCOUNT FROM LIST	\$50,209.89		
CHASSIS PRICE less DISCOUNT	\$119,993.12		
OPTIONS LIST PRICE TSP		\$33,341.00	
OPTIONS DISCOUNT FROM LIST PRICE		\$9,002.07	
OPTION PRICE LESS DISCOUNT		\$24,338.93	
CHASSIS PRICE WITH CONTRACT OPTIONS AND DISCOUNT =			\$144,332.05
Net Contract Items:			\$0.00
TOTAL WITH NON CONTRACT OPTIONS =			\$144,332.05
DELIVERY CHARGE FROM CHART			\$230.00
TOTAL PRICE FOR CHASSIS WITH ALL OPTIONS DELIVERED			\$144,562.05
LIST PRICE FOR BODY & Equipment: N/A			\$0.00
CONTRACT DISCOUNT 30%			\$0.00
TOTAL PRICE FOR BODY & Equipment : N/A			\$0.00

TOTAL PRICE FOR COMPLETE TRUCK: **\$144,562.05**

Options Not included in Price:

5 year Plan 2 engine warranty.....	\$1986.00
5 Year Allison Transmission warranty.....	\$802.00

Sincerely, Greg Angwin

MAEK



TECHNICAL SPECIFICATION

GRANITE 64FR

APPLICATION PACKAGES	DESCRIPTION	WEIGHT (LB)		LIST PRICE
		FRONT	REAR	
PK70X7	GRANITE AF CONFIG. PKG.	0	0	10

CUSTOMER/VEHICLE INFO	DESCRIPTION	WEIGHT (LB)		LIST PRICE
		FRONT	REAR	
S 002EF2	CHASSIS (BASE MODEL)	5,144	1,903	0
S 99X93X	ASSEMBLY PLANT	0	0	0
S MP2001	CUSTOMER FLEET SIZE	0	0	0
013002	TYPE OF SERVICE	0	0	0
S M98018	WARRANTY REGISTRATION LOCATION	0	0	0
S 505015	INITIAL REGISTRATION LOCATION	0	0	0
S 534014	LANGUAGE-PUBS/DECAL/SIGNS	0	0	0
S DHX10X	ROAD CONDITION	0	0	0
0050M5	VEHICLE USE & BODY/TRAILER TYPE	0	0	0
S DKX99X	GROSS COMBINATION WEIGHT	0	0	0
S 70BB1X	BRAKE REGULATION	0	0	0
QCXA1X	TOPOGRAPHY	0	0	0
S E1BD1X	AMBIENT TEMP UPPER LIMIT (GTA)	0	0	0
S 032A89	TERRAIN GRADE	0	0	0
S 033A10	LOADING SURFACE	0	0	0
S 0342A2	VEHICLE VOCATION	0	0	0

TECHNICAL SPECIFICATION (cont.)

			WEIGHT (LB)		LIST PRICE
ENGINE/TRANSMISSIONS	DESCRIPTION	FRONT	REAR		
100350	ENGINE PACKAGE, COMBUSTION	MP8-455M MACK 455HP @ 1500-1900 RPM (PEAK) 2100 RPM (GOV) 1760 LB-FT, US'21	2,165	-540	4,204
136AS6	TRANSMISSION	4500 RDS 6 SP-ALLISON RUGGED DUTY SERIES GEN 5 W/PROGNOSTICS	732	245	13,720
S V4EZ9X	GEARBOX 12TH GEAR LOCK-OUT	WITHOUT 12TH GEARBOX GEAR LOCK-OUT	0	0	0

			WEIGHT (LB)		LIST PRICE
EXHAUST/EMISSIONS	DESCRIPTION	FRONT	REAR		
S CIRAA4	CARB 2008 IDLE REGULATION	IDLE EMISSION CERTIFICATION, CARB (WITH DECAL LOCATED ON LOWER LH CORNER / DRIVER DOOR	0	0	0
S DPF04F	DPF DIESEL PARTICULATE FILTER	CLEARTECH ONE BOX E.A.T.S. RH SIDE UNDER CAB US17 / US21	0	0	0
8NAB1X	DPF COVER	DPF COVER STAINLESS STEEL, POLISHED	0	0	251
DF10P1	DEF TANK	8.7 GALLON (33 L) 26" LEFT SIDE FUEL TANK MTD	0	0	0
130AD7	EXHAUST	SINGLE VERTICAL RIGHT SIDE CAB MOUNTED, LOWER VENTURI DIFFUSER, TURNED END	-35	-17	368
KRXAPX	EXHAUST STACK HEIGHT	9' 6" FROM GROUND	0	0	0
QOAC4X	EXHAUST SYSTEM MATERIAL FINISH	SINGLE, BRIGHT FINISH HEAT SHIELD AND SCR COVER (IF EQUIPPED)	0	0	22
78AC8X	EMISSION ON BOARD DIAG CONTROL	EMISSION OBD, DISPLAY ONLY, USA2020	0	0	0

			WEIGHT (LB)		LIST PRICE
ENGINE EQUIPMENT	DESCRIPTION	FRONT	REAR		
S 125045	AIR CLEANER	UNDER HOOD SINGLE ELEMENT DRY TYPE W/AIR INTAKE FROM BOTH SIDES OF HOOD	0	0	0
S 121AA5	BUG SCREEN	BLACK ALUMINUM MOUNTED BEHIND GRILLE, WITHOUT WINTER FRONT COVER	0	0	0
S VWXAZX	COMPRESSOR CAPACITY	MERITOR/WABCO 318 (18.7 CFM)	0	0	0
S VHXEDX	AIR DRYER - MANUFACTURER	WABCO 1200P W/TURBO CUT OFF VALVE, W/COALESCING OIL FILTER, HEATED	0	0	0
132AB2	ALTERNATOR	DELCO 12V 135A (35SI) BRUSHLESS	27	0	150
316AA7	BATTERIES	(3) MACK 12V 1000/3000 CCA THREADED STUD TYPE	-15	7	97
S 393AA2	BATTERY BOX - MOUNTING	LH RAIL UNDER CAB FORWARD OF FUEL TANK (3 BATTERY MAX)	-8	-4	0
S L5XA1X	BATTERY BOX COVER	MOLDED PLASTIC	0	0	0
318AA3	BATTERY DISCONNECT SWITCH	FLAMING RIVER BIG SWITCH WIRED TO POSITIVE SIDE	3	0	142
S NCXA5X	STARTER MOTOR	12 VOLT DELCO 39MT-MXT	31	0	0
110AA6	ENGINE BRAKE	MACK MP8 POWERLEASH	0	0	0
S JMXB1X	ENGINE BRAKE LIGHTING (CA)	VEHICLE AND TRAILER (IF APPLICABLE) STOP LAMPS ACTIVATE UPON SERVICE BRAKE APPLICATION ONLY(3899000)	0	0	0
S 118AB8	FAN DRIVE	BEHR FAN AND ELECTRONIC MODULATING VISCIOUS FAN DRIVE	0	0	0
S 119AI9	COOLANT PROTECTION	ETHYLENE GLYCOL FULLY FORMULATED COOLANT (50/50 MIX DYED PINK) TO -34DEG, W/FILTER	0	0	0
S 124AA3	HOSES - RADIATOR/HEATER	MACK EPDM RADIATOR & HEATER HOSES	0	0	0
S 293AA2	FUEL-WATER SEPARATOR	MACK W/MANUAL DRAIN VALVE (INTEGRAL W/PRIMARY FUEL FILTER)	0	0	0

TECHNICAL SPECIFICATION (cont.)

				WEIGHT (LB)		LIST PRICE
ENGINE EQUIPMENT		DESCRIPTION	FRONT	REAR		
S	MBXA1X	PRIMARY FUEL FILTER POSITION (CA)	0	0	0	
S	MCA00A	ENGINE HEATERS	0	0	0	
	QHXABX	OIL PAN	0	0	185	
S	2YBZ1X	ENGINE STOP, EMERGENCY (CA)	0	0	0	

				WEIGHT (LB)		LIST PRICE
CLUTCH/TRANS EQUIPMENT		DESCRIPTION	FRONT	REAR		
	492007	GEAR SHIFTER	0	0	0	
	195AB0	DRIVELINE - MAIN	5	5	-782	
	204AA5	DRIVELINE - INTERAXLE	0	0	-268	
	76AA1X	PROPELLR SHAFT MAIN, UNVSL JNT	0	0	0	
S	8WAAAX	PROP SHAFT INTERAXL UNIV JOINT	0	0	0	
S	4LDA1X	TRANSMISSION OUTPUT TORQUE	0	0	0	
S	RCXB1X	BELL HOUSING	0	0	0	
	7RXAEX	LUBRICANTS, TRANSMISSION	0	0	443	
	139019	TRANSMISSION OIL COOLER	0	0	384	

				WEIGHT (LB)		LIST PRICE
FRONT AXLE EQUIPMENT		DESCRIPTION	FRONT	REAR		
	240AA3	FRONT AXLE	428	0	392	
	244AC3	SPRINGS - FRONT	155	0	91	
S	241081	FRONT AXLE BRAKES	29	0	0	
S	U3XA1X	BRAKE, FRONT	0	0	0	
	UDXA1X	FRONT AXLE BRAKE DUST SHIELD	5	0	27	
S	U0AA1X	FRONT BRAKE ADJ. MANUFACTURE	0	0	0	
S	V7AD1X	FRONT BRAKE CHAMBER MFG.	0	0	0	
	YHXB1X	FRONT SPRING BIAS	16	0	0	
S	0KXA1X	HUB MATERIAL, FRONT	157	0	0	
S	1KAA1X	SHOCK ABSORBER, FRONT	0	0	0	
	245AB0	STEERING	206	0	837	
S	7VXC1X	LUBRICANTS, FRONT AXLE	0	0	0	

				WEIGHT (LB)		LIST PRICE
REAR AXLE EQUIPMENT		DESCRIPTION	FRONT	REAR		
	268AA9	REAR AXLES - TANDEM	0	1,614	2,487	
S	6MAA1X	REAR AXLE CASING WIDTH	0	0	0	

TECHNICAL SPECIFICATION (cont.)

			WEIGHT (LB)		
REAR AXLE EQUIPMENT	DESCRIPTION		FRONT	REAR	LIST PRICE
S 018AA6	CARRIER - REAR AXLE	CRDP150/151 AVAILABLE WITH OPTIONAL DRIVER CONTROLLED INTERWHEEL DIFFERENTIAL LOCKS, SEE 254 SYMBOL	0	0	0
TAX2FX	REAR AXLE RATIO	5.31 RATIO	0	0	0
1860K6	REAR SUSPENSION - TANDEM	SS462 MACK MULTILEAF (CAMELBACK) 46000# - EXTRA THICK SPRING THICKNESS	0	1,930	635
402AA3	SPRINGS - ANTI-SWAY	SPRINGS, ANTI-SWAY	0	104	0
S XZX1X	REAR SUSP. BEAM BUSHINGS	BRONZE	0	36	0
S GWXABX	BOGIE SPREAD, REAR	50" AXLE SPACING (BOGIE WHEELBASE)	0	0	0
S 2AAAX	REAR SPRING INSULATOR MAT'L	RUBBER SHOCK INSULATORS	0	0	0
S XYXB1X	TRANSVERSE TORQUE RODS, R SUSP	TRANSVERSE TORQUE ROD (REAR AXLE ONLY)	0	0	0
UGXA1X	AUX.PARKING BRAKE CHAMBERS	AUXILIARY PARK, TWO EXTRA PARKING BRAKE CHAMBERS	0	20	0
S 253AA4	BRAKES - REAR	MERITOR "S" CAM 16.5"x7" Q+ (Total for QTY = 2)	0	-35	0
MAXCAX	BRAKE LINING MATERIAL DRIVE	ABEX 931-162 (MERITOR R301) (REAR EACH AXLE 23,000LBS MAX)	0	0	0
S U4XA1X	BRAKE, DRIVE, REAR	CAST IRON	0	0	0
S U1AA1X	REAR BRAKE ADJ MANUFACTURE	HALDEX - AUTOMATIC	0	0	0
UEXA1X	DRIVE AXLE BRAKE DUST SHIELD	DUST SHIELDS FOR REAR AXLE	0	12	49
S V1AB1X	REAR BRAKE CHAMBER SIZE	REAR SPRING BRAKE CHAMBERS 30/30 TYPE	0	0	0
S 300AD0	REAR BRAKE CHAMBER	MGM TR-T; TAMPER-RESISTANT BRAKE CHAMBERS (Total for QTY = 2)	0	0	0
S 0LX15X	HUB MATERIAL, DRIVE	IRON PRESET REAR HUB W/INTEGRATED SPINDLE NUT	0	318	0
S 3LAC1X	POWER DIVIDER LOCKOUT	POWER DIVIDER LOCKOUT, W/BUZZER & LIGHT	0	40	0
S 7WX1X	LUBRICANTS, REAR AXLE(s)	FACTORY OPTION LUBE - REAR AXLE	0	0	0
254AB5	TRACTION DIFFERENTIAL	DRIVER CONTROLLED INTER WHEEL DIFFERENTIAL LOCK ALL RR AXLES, MANUAL AIR VALVE W/WARNING LIGHT.	0	18	1,423
S 9GAAAX	ABS SENSOR & MODULATOR	4S/4M SYSTEM REAR WHEEL END SENSORS	0	0	0
S 698AA5	ANTILOCK BRAKE SYSTEM	BENDIX WITH TRACTION CONTROL	0	0	0
S URXD1X	BRAKE VALVE VERSION	BENDIX SWITCHES AND VALVES WHERE POSSIBLE	0	0	0
S 3ZAA1X	SPRING BRAKE INVERSION VALVE	TRACTOR SPRING BRAKE INVERSION VALVE	5	0	0

			WEIGHT (LB)		
FRAME EQUIPMENT/FUEL TANKS	DESCRIPTION		FRONT	REAR	LIST PRICE
271216	WHEELBASE	216"	128	128	0
374067	AF (OVERHANG)	67"	-19	258	0
274AA8	FRAME RAILS	STEEL - 300MM X 90MM X 11.1MM -- (11.81" X 3.54" X 0.437")	0	0	849
5CAZ1X	FRONT FRAME EXT. (BOLTED ON)	W/O FRONT FRAME EXTENSION	0	0	-207
A0XF3X	FRONT FRAME LENGTH	BUMPER POSITION EXTENDED 20" (SNOW)	131	-13	1,531
S 281AA5	CROSSMEMBERS	BOC AND INTERMEDIATE(S) STEEL HD BACK-TO-BACK CHANNEL	0	0	0
S Q5AA1X	REAR CROSSMEMBER OPTIONS	FURNISH STANDARD STEEL CLOSING REAR CROSSMEMBER	0	0	0

TECHNICAL SPECIFICATION (cont.)

				WEIGHT (LB)		LIST PRICE
FRAME EQUIPMENT/FUEL TANKS		DESCRIPTION	FRONT	REAR		
S	4DXM9X	FRONT BUMPER	EXTENDED-SWEPT BACK-STEEL	0	0	0
S	4EXG1X	TOWING DEVICE, FRONT	HOOKS	0	0	0
S	2RAA1X	FUEL LEVEL SENDER UNIT, LIQUID	BASIC FUEL LEVEL SENDER MOUNTED ON L.H TANK	0	0	0
	288AF3	FUEL TANK - LH	72 GALLON (275 L) 26" ALUMINUM, SLEEVED D-SHAPED	67	34	250
S	290AA1	FUEL TANK - RH	W/O RH FUEL TANK	0	0	0
S	JHXB1X	FUEL HOSES, LIQUID	BRAIDED HOSE	5	3	0
	12AA1X	FUEL LINE OPTIONS, LIQUID	W/O FUEL LINE OPTION	0	0	0
S	KFXA1X	FUEL TANK CAP	NON-LOCKABLE FUEL TANK CAP	0	0	0
S	Q2AA1X	CAB INSTEP VERSION	STANDARD 2 STEP CAB ACCESS	0	0	0
	223AA3	STEPS (BRIGHT) - FUEL TANK	STANDARD FINISH STEPS AND BRIGHT FINISH STRAPS	0	0	0

				WEIGHT (LB)		LIST PRICE
AIR/BRAKE		DESCRIPTION	FRONT	REAR		
S	UWXC1X	AIRTANK DRAIN VALVE	MANUAL (PETCOCK) DRAIN VALVES ON ALL TANKS	0	0	0
	U2XA1X	AIRTANK MATERIAL	ALUMINUM, PAINTED	-24	0	282
S	KOXA1X	AIR DRYER POSITION (CA)	W/O RELOCATION OPTION	0	0	0
S	141AA1	RELOCATE AIR RESERVOIRS	W/O RELOCATED AIR TANKS	0	0	0
S	1JAAAX	PARKING BRAKE VALVE	SINGLE VALVE SYSTEM	0	0	0

				WEIGHT (LB)		LIST PRICE
ELECTRICAL		DESCRIPTION	FRONT	REAR		
	5RXA5X	BACK-UP ALARM	ECCO BACK-UP ALARM SA917 (AMBIENT NOISE SENSITIVE) 87-112 dB	0	3	144
S	5FBB1X	MARKER/DIRECTIONAL SIGNAL	W/O MARKER/DIR SIGNAL OPTION	0	0	0
	312AB5	ROOF MARKER LIGHT	(5) GROTE LED LAMPS	3	0	0
S	LSXH1X	DAYTIME RUNNING LIGHTS	PARK BRAKE AND ENGINE RUNNING ACTIVATED	0	0	0
S	NEXC1X	TAIL LAMPS	INCANDESCENT TAIL LAMPS	0	0	0

				WEIGHT (LB)		LIST PRICE
TRAILER CONNECTIONS		DESCRIPTION	FRONT	REAR		
S	WGXB1X	TRAILER BRAKE VALVE	W/O HAND CONTROL VALVE	-6	0	0
S	3SAZ1X	TRAILER CONNECTORS HOLDER	OMIT TRAILER CONNECTORS HOLDER	3	0	0

				WEIGHT (LB)		LIST PRICE
PTO		DESCRIPTION	FRONT	REAR		
	TYXE1X	POWER TAKE OFF CONTROL	TRANSMISSION PTO SWITCH AND LIGHT WITH WIRING AND PIPING FOR LOCAL INSTALLATION	3	0	0
S	2WAZ1X	PTO TRANS NEUTRAL CONTRL CHECK	W/O NEUTRAL CONTROL	0	0	0
S	B83083	BODY BUILDER INTERFACE	BODY LINK III W/CAB PASS-THRU	5	5	0

TECHNICAL SPECIFICATION (cont.)

SPECIALTY EQUIPMENT	DESCRIPTION	WEIGHT (LB)		LIST PRICE	
		FRONT	REAR		
S 2QEZ1X	BLINDSPOT DETECTION ALARM	WITHOUT BLINDSPOT DETECTION AUDIO ALARM DISABLE	0	0	0

CAB INTERIOR (A THRU G)	DESCRIPTION	WEIGHT (LB)		LIST PRICE	
		FRONT	REAR		
S 198048	GAUGES - UNIT OF MEASURE	U.S. UNITS (PREDOMINANT)	0	0	0
D9AAAX	GAUGE - EXHAUST PYROMETER	EXHAUST PYROMETER GAUGE	0	0	55
S 173AA5	AIR CONDITIONING/HEATER	BLEND AIR HVAC W/"ATC" TEMP REGULATION	0	0	0
S 10XAHX	DOME LAMP, INTERIOR	(4) DOME LAMPS - DOOR AND SWITCH ACTIVATED	0	0	0
S 3XAA1X	DASH INDICATOR - LAMP BODY OUT OF POS	DASH MTD, INDICATOR BODY/HOIST UP "BODYBUILDER LAMP"	0	0	0
S 184AA2	FLOOR COVERING	POLYURETHANE FLOOR MAT WITHOUT REMOVABLE INSERTS	0	0	0

CAB INTERIOR (H THRU R)	DESCRIPTION	WEIGHT (LB)		LIST PRICE	
		FRONT	REAR		
S C52082	INSTMNT CLUSTER LANGUAGE	DEFAULT: ENGLISH, SPANISH, FRENCH	0	0	0
S 20XA1X	KEY TYPES FOR DOORS	ALL CHASSIS KEYED AT RANDOM	0	0	0
S 13AA1X	DOOR OPENING OPTIONS	W/O ELECTRONIC KEYLESS ENTRY	0	0	0
S 17400N	AUDIO ACCOMMODATION	PREMIUM STEREO, AM/FM, CD-PLAYER, MP3, WEATHER BAND, BLUETOOTH	0	0	0
S 73AC1X	ANTENNA - RADIO	RADIO ANTENNA, CAB MOUNTED BEHIND LH DOOR	0	0	0
0LAZ1X	AUDIO SHUTOFF	W/O AUTO RADIO SHUTOFF OPTION	0	0	-69
S 1WAB1X	POWER LEADS	POWER LEADS (5-WAY BINDING POSTS FOR CB RADIO) IN HEADER CONSOLE	0	0	0
S 5CXB2X	AUDIO SPEAKER LOCATION	SPEAKER LOCATION, IN DOORS, MIDDLE HIGH SIDE PANEL	0	0	0
S 5JXAIX	COM.RADIO PREP KIT (CB)	CB RADIO MOUNTING REINFORCEMENT IN HEADER CONSOLE	0	0	0
S 21XA1X	AUXILIARY REAR WINDOW	REAR WINDOW (FIXED TYPE)	0	0	0
S IFXB1X	REAR WALL STORAGE COMPARTMENT	STORAGE POUCH REAR	0	0	0

CAB INTERIOR (S THRU Z)	DESCRIPTION	WEIGHT (LB)		LIST PRICE	
		FRONT	REAR		
S 004014	INTERIOR TRIM LEVELS	STANDARD PACKAGE, STEEL GRAY (Package 11A)	0	0	0
S 196AAA	SEAT - DRIVER'S	MACK-AIR, HIGH BACK, 1 CHAMBER AIR LUMBAR	0	0	0
S MAPB2X	SEAT COVERING - DRIVER'S	DRIVER'S SEAT - STEEL GREY VINYL	0	0	0
S 197AA1	SEAT - PASSENGER'S	MACK-FIXED, HIGH BACK	0	0	0
S MAQB2X	SEAT COVERING - PASSENGER'S	PASSENGER'S SEAT - STEEL GREY VINYL	0	0	0
S 592092	SEAT BELT(S)	LAP & SHOULDER (BOTH SEATS) CAB MOUNTED SHOULDER BELT ADJUSTMENT (NOT AVAIL W/EXTENDED RIDER SEAT)	0	0	0
S 2QAA1X	IGNITION TYPE	KEY TYPE	0	0	0
161011	STEERING WHEEL	2 SPOKE URETHANE GRIP, SATIN ALUMINUM SPOKES, WITH SWITCHES	0	0	28

TECHNICAL SPECIFICATION (cont.)

				WEIGHT (LB)		LIST PRICE
CAB INTERIOR (S THRU Z)		DESCRIPTION	FRONT	REAR		
S	WSXBAX	WINDSHIELD TYPE	2-PIECE WINDSHIELD	0	0	0
	145AA5	CAB GLASS	HEATED TINTED WINDSHIELD, TINTED SIDE AND REAR WINDOW	0	0	498
S	JQXAAX	WASHER RESERVOIR POSITION	W/O WINDSHIELD WASHER OPTION	0	0	0
S	148AA3	WINDSHIELD WIPERS	2 SPEED ELECTRIC MOTOR W/INTERMITTENT FEATURE	0	0	0

				WEIGHT (LB)		LIST PRICE
CAB - SLEEPER BOX		DESCRIPTION	FRONT	REAR		
S	768018	SLEEPER BOX - WINDOW	WITHOUT SLEEPER BOX WINDOWS	0	0	0

				WEIGHT (LB)		LIST PRICE
CAB EXTERIOR		DESCRIPTION	FRONT	REAR		
	0EAA1X	AIR INTAKE GRILLE, FINISH	BRIGHT FINISH GRILLE	0	0	0
S	4UAA1X	HOOD LATCH, FINISH	PAINTED HOOD LATCHES	0	0	0
	400AA6	GRILLE	BRIGHT FINISH BARS W/BRIGHT FINISH SURROUND GRILL MOUNTED	0	0	221
S	Q4XADX	DOOR WINDOW FRONT	AUX. WIN. DOOR ON RIGHT SIDE NON STG WHL POS. DEPEND	0	0	0
S	2KXB1X	FRONT WHEEL OPENING	FENDER EXTENSIONS	5	0	0
	5870B7	GRAB HANDLES	BF EXTERIOR CAB GRAB HANDLES, BLACK GRAB HANDLE RH INTERIOR WINDSHIELD POST	0	0	0
S	2DX90X	REAR CAB SUSPENSION	REAR CAB SUSPENSION, AIR	0	0	0
	26XA1X	HOOD HATCH	WITH INSPECTION HATCH FOR SNOWPLOW HOOD	0	0	0
	154AC2	HORN - AIR	(1) MACK RECTANGULAR SINGLE TRUMPET, BRIGHT FINISH ALUMINUM W/SNOW SHIELD	5	0	19
S	LXXC1X	HORN - ELECTRICAL	SINGLE TONE	0	0	0
	1520D2	MIRRORS - EXTERIOR	FLAT MIRROR - POLISHED ALUMINUM FINSH, HEATED, WITH LAMPS	0	0	177
	153AA3	MIRRORS - CONVEX TYPE CAB DOORS	BRIGHT FINISH, LH & RH, 8" DIAMETER HEATED CONVEX	3	0	49
	157027	SUN VISOR - EXTERIOR	SUN VISOR, EXTERIOR, FIBERGLASS (PAINTED)	12	0	213

				WEIGHT (LB)		LIST PRICE	
WHEELS & TIRES		DESCRIPTION	FRONT	REAR			
	900AZ6	TIRES BRAND/TYPE - FRONT	315/80R22.5 L MICHELIN XZUS2 (20000 lbs) (Total for QTY = 2)		327	0	718
S	4WCC1X	GHG STEER TIRE CATEGORY (PAWS)	LOW ROLLING RESISTANCE, BETTER FUEL ECONOMY		0	0	0
	531AE4	WHEELS - FRONT	22.5x9.00 HAYES LEMMERZ STEEL DISC 10-HOLE HUB PILOTED, FIVE HAND HOLE (11 1/4"/286mm BC) 6.42" INSET (Total for QTY = 2)		203	0	-62
S	FWT002	FRONT AXLE TIRE & WHEEL QUANTITY	TWO FRONT TIRES & WHEELS		0	0	0
	901BG3	TIRES BRAND/TYPE - REAR	12R22.5 H MICHELIN XDN2 (27120 lbs) (DRIVE ONLY) (Total for QTY = 8)		0	1,182	3,832
	4XCE1X	GHG DRIVE TIRE CATEGORY (PAWS)	BASIC ROLLING RESISTANCE, POOR FUEL ECONOMY		0	0	0

TECHNICAL SPECIFICATION (cont.)

WHEELS & TIRES			DESCRIPTION	WEIGHT (LB)		LIST PRICE
				FRONT	REAR	
	346AE8	WHEELS - REAR	22.5x9.00 HAYES LEMMERZ STEEL DISC 10-HOLE HUB PILOTED, FIVE HAND HOLE (11 1/4"/286 mm BC) (Total for QTY = 8)	0	812	-104
S	RWT008	REAR AXLE TIRE & WHEEL QUANTITY	EIGHT REAR AXLE TIRES & WHEELS	0	0	0
	H1EA1X	DRIVE WHEEL STUDS	DRIVE WHEEL STUDS BASIC LENGTH	0	0	-76
S	15XABX	TIRE INFLATION VALVE	STANDARD VALVE STEMS AND CAPS	0	0	0
S	0XXZ1X	WHEEL TRIM PACKAGE DRIVE AXLE	WITHOUT WHEEL TRIM PACKAGE DRIVE	0	0	0
S	80AA1X	WHEEL NUT & FINISH, FRONT	WHEEL NUT BASIC FINISH, FRONT	0	0	0
S	3PBA1X	WHEEL NUT FINISH, REAR (CA)	WHEEL NUT BASIC FINISH, REAR	0	0	0

COMMUNICATION SYSTEMS			DESCRIPTION	WEIGHT (LB)		LIST PRICE
				FRONT	REAR	
S	3YAA1X	CO-PILOT - DISPLAY FEATURES ACCESS LEVEL	CO-PILOT DISPLAY, DRIVER ACCESS LEVEL 1	0	0	0
S	M30060	TELEMATIC GATEWAY	TELEMATICS GATEWAY, 4G/LTE AND WLAN SYSTEM WITH DIAGNOSTIC SERVICES	0	0	0
	9YDA1X	SOFTWARE DOWNLOAD NOTIFICATION	SOFTWARE DOWNLOAD NOTIFICATION TO DRIVER, POPUP & ICON	0	0	0

ENGINE ELECTRONICS			DESCRIPTION	WEIGHT (LB)		LIST PRICE
				FRONT	REAR	
S	WOXA1X	OIL PRESSURE, ENGINE SHUTDOWN	OIL PRESSURE, ENGINE SHUTDOWN	0	0	0
S	WMXA1X	COOLANT TEMP, ENGINE SHUTDOWN	COOLANT TEMP, ENGINE SHUTDOWN	0	0	0
S	K5XA2X	ENGINE PROTECTION SYSTEM	ENGINE PROTECTION (SHUTDOWN)	0	0	0
S	K7XH3X	ENGINE IDLE CONTROL	IDLE CONTROL, 650 RPM	0	0	0
S	X0AB0X	SMART IDLE ELEVATED IDLE RPM TIME	INCREASE 10 MINUTE MAXIMUM TIME	0	0	0
S	M3CA1X	IDLE S/D ABS TAMPER CHECK	IDLE SHUTDOWN ABS TAMPER CHECK, ENABLED	0	0	0
S	B1ACAX	IDLE S/D WARNING TIME	30 SEC IDLE S/D WARNING TIME	0	0	0
S	A8AALX	IDLE S/D IF WARM-UP TEMP	38C DEG (100F), WARM UP TEMP DELAY	0	0	0
S	A4AAEX	IDLE S/D WARM-UP TIMER	5 MIN. WARM UP TIME DELAY	0	0	0
S	A6AABX	IDLE S/D IF PTO ACTIVE	ENGINE IDLE SHUTDOWN TIME OVERRIDDEN IF PTO ACTIVE	0	0	0
S	B0AAAX	IDLE SHUTDOWN IF POWER > LIMIT	ENG IDLE SHUTDOWN TIME OVERRIDDEN IF TORQUE > THAN LIMIT	0	0	0
S	M4CB1X	IDLE S/D OVERRIDE %ENGINE LOAD	IDLE SHUTDOWN OVERRIDE UPTO 20% ENGINE LOAD THRESHOLD	0	0	0
S	D2AAFX	AMBIENT TEMP MIN TRESHOLD	AMBIENT TEMP MIN TRESHOLD, 16 DEG C, (60 DEG F)	0	0	0
S	D3AAEX	AMBIENT TEMP MAX TRESHOLD	AMBIENT TEMP MAX TRESHOLD, 27 DEG C, (80 DEG F)	0	0	0
S	B3ABAX	EL HD THROTTLE,MAX ROAD SPEED	ELECTRONIC HAND THROTTLE, MAX ROAD SPEED, 16 KMH (10 MPH)	0	0	0
	B6ACEX	EL HAND THROTTLE,MAX ENG SPEED	ELECTRONIC HAND THROTTLE, MAX ENGINE SPEED, 2100 RPM	0	0	0
S	B4ADAX	EL HAND THROTTLE,MIN ENG SPEED	ELECTRONIC HAND THROTTLE, MIN ENGINE SPEED, 700 RPM	0	0	0

TECHNICAL SPECIFICATION (cont.)

ENGINE ELECTRONICS			DESCRIPTION	WEIGHT (LB)		LIST PRICE
				FRONT	REAR	
S	B9AABX	EL HD THROTTLE,SPEED RAMP RATE	ELECTRONIC HAND THROTTLE, SPEED RAMP RATE, 100 RPM/SEC	0	0	0

TRANSMISSION ELECTRONICS			DESCRIPTION	WEIGHT (LB)		LIST PRICE
				FRONT	REAR	
	7790M9	TRANSMISSION ELECTRONICS PACKAGE	DUMP/VOCATIONAL(223) - REQUIRES SERVICE BRAKE TO ENGAGE GEAR	0	0	0
S	MAV01V	TRANSMISSION ELECTRONIC SHIFTING PROPERTIES	W/O ALLISON FUELSENSE 2.0 PROGRAMMING	0	0	0

VEHICLE ELECTRONICS			DESCRIPTION	WEIGHT (LB)		LIST PRICE
				FRONT	REAR	
S	JDXA1X	CRUISE CONTROL	CRUISE CONTROL	0	0	0
S	JFXLLX	CRUISE CONTROL, MAX SPEED	MAX CRUISE, 105 KPH (65 MPH)	0	0	0
S	E3AACX	CRUISE CONTROL MIN SPEED	MIN CRUISE, 32 KPH (20 MPH)	0	0	0
S	E5AACX	ENG BRK ENGAGE IN CRUISE	ENG BRK ENGAGE IN CRUISE, 3 MPH, ABOVE SET SPEED	0	0	0
	Y3CC5X	PEDAL RSL SETTING	105 KM/H PEDAL ROAD SPEED LIMITER (65MPH)	0	0	0
S	JCXE6X	ROAD SPEED LIMITER SETTING	105 KM/H ROAD SPEED LIMITER(65 MPH)	0	0	0
S	L2CA1X	PDLO ENGAGED VLS	POWER DIVIDER LOCK OUT (PDLO) ROAD SPEED LIMIT 8KMH (5MPH)	0	0	0
S	A4BAAX	DETECTION SPEED SENSR TMRNG	DETECTION OF SPEED SENSOR TAMPERING, ENABLE	0	0	0
S	8RXAEX	ENG TORQUE LIMIT,SPEED SENSOR	ENG TORQUE LIMITED TO 50%, IF SPEED SENSOR TAMPER DETECTED	0	0	0
S	X3CB1X	DRIVER ID FUNCTION	DRIVER ID FUNCTION, DISABLED	0	0	0
S	0PAZ1X	DR PERFORMANCE PARAMETERS	WITHOUT DRIVER PERFORMANCE PARAMETERS	0	0	0
S	G5AAHX	ENGINE OVERSPEED,ALL COND, LOG	ENGINE OVERSPEED, ALL CONDITIONS, TIME LOG IF ABOVE 2200 RPM	0	0	0
S	G2AAGX	ENGINE OVERSPEED,FUELED, LOG	ENGINE OVERSPEED, FUELED, TIME LOG IF ABOVE 2100 RPM	0	0	0
S	G4AAUX	VEHICLE OVERSPEED,ALL COND,LOG	VEHICLE OVERSPEED,ALL COND, TIME LOG IF ABOVE 75MPH (121KMH)	0	0	0
S	G3AAPX	VEHICLE OVERSPEED, FUELED, LOG	VEHICLE OVERSPEED, FUELED, TIME LOG IF ABOVE 70MPH (113KMH)	0	0	0
S	G1AABX	ENGINE IDLE DELAY TO LOG	ENGINE IDLE DELAY TO START LOG, 2 MIN	0	0	0
S	W9A01X	PERIODIC TRIP LOG DAY OF MONTH	PERIODIC TRIP LOG, DAY 1 OF THE MONTH	0	0	0

PTO ELECTRONICS			DESCRIPTION	WEIGHT (LB)		LIST PRICE
				FRONT	REAR	
S	F3AAEX	PTO1 SINGLE SPEED CONTROL RPM.	PTO 1ST, SINGLE SPEED SETTING, 1000 RPM	0	0	0
S	F5AABX	PTO 1ST, MAX ROAD SPEED	1ST PTO, MAX ROAD SPEED, 10 MPH (16 KPH)	0	0	0
S	F6AABX	PTO 1ST, SPEED RAMP RATE	PTO 1ST, SPEED RAMP RATE 100 RPM/SEC	0	0	0
S	F7AAPX	PTO 1ST, MAX ENGINE SPEED	PTO 1ST, MAX ENGINE SPEED, 2100 RPM	0	0	0
S	F8AAGX	PTO 1ST, ROAD SPEED LIMIT	PTO 1ST, ROAD SPEED LIMIT, 97 KMH (60 MPH)	0	0	0

TECHNICAL SPECIFICATION (cont.)

			WEIGHT (LB)		LIST PRICE	
PTO ELECTRONICS			FRONT	REAR		
		DESCRIPTION				
S	F9AABX	PTO 1ST, MINIMUM ENGINE SPEED	PTO 1ST, MINIMUM ENGINE SPEED, 600 RPM	0	0	0
S	H6AAEX	PTO 2ND, SINGLE SPEED SETTING	PTO2 SINGLE SPEED SETTING, 1000 RPM	0	0	0
S	H0AABX	PTO 2ND, MAX ROAD SPEED	2ND PTO, MAX ROAD SPEED, 10 MPH (16 KPH)	0	0	0
S	G9AABX	PTO 2ND, SPEED RAMP RATE	PTO 2ND, SPEED RAMP RATE 100 RPM/SEC	0	0	0
S	H7AANX	PTO 2ND, MAX ENGINE SPEED	PTO 2ND, MAX ENGINE SPEED, 2100 RPM	0	0	0
S	H5AAGX	PTO 2ND, ROAD SPEED LIMIT	PTO 2ND, ROAD SPEED LIMIT, 97 KMH (60 MPH)	0	0	0
S	G8AABX	PTO 2ND, MINIMUM ENGINE SPEED	PTO 2ND, MINIMUM ENGINE SPEED, 600 RPM	0	0	0

			WEIGHT (LB)		LIST PRICE	
PAINT			FRONT	REAR		
		DESCRIPTION				
S	950AD0	PAINT DESIGN	SINGLE COLOR	0	0	0
S	924014	PAINT TYPE	SOLID PAINT	0	0	0
	944AA3	PAINT COLOR - FIRST COLOR	MACK YELLOW; P9016	0	0	70
S	945998	PAINT COLOR - SECOND COLOR	NO SECOND TRUCK COLOR PROVIDED; NO COLOR	0	0	0
S	946998	PAINT COLOR - THIRD COLOR	NO THIRD TRUCK COLOR PROVIDED; NO COLOR	0	0	0
S	996AA3	PAINT - CAB PAINT SYSTEM	PAINT - CAB, URETHANE CLEAR COAT	0	0	0
S	MPB944	CAB COLOR	SAME AS FIRST COLOR - CAB	0	0	0
S	MPD944	HOOD COLOR	SAME AS FIRST COLOR - HOOD	0	0	0
	966944	SUN VISOR COLOR	SAME AS FIRST COLOR - SUN VISOR	0	0	56
S	MPC998	SLEEPER ROOF COLOR	WITHOUT SLEEPER ROOF COLOR	0	0	0
S	MPA998	ROOF FAIRING COLOR	WITHOUT ROOF FAIRING	0	0	0
S	951AA6	CHASSIS RUNNING GEAR	MACK BLACK (URETHANE)	0	0	0
S	958018	BUMPER	PAINT BUMPER SAME COLOR AS CHASSIS RUNNING GEAR	0	0	0
S	959019	FUEL TANK - ***NO INVENTED VARIANTS ALLOWED in the FUEL TANK PAINT FAMILY***	W/O OPTIONAL FUEL TANK PAINT	0	0	0
	07XC1X	FRONT WHEEL PAINT	PRE-FINISHED POWDER COAT WHITE	0	0	0
	08XC1X	DRIVE WHEEL PAINT	PRE-FINISHED POWDER COAT WHITE	0	0	0
S	954AA1	PAINTED DISC WHEELS, FRONT	WITHOUT PAINT	0	0	0
S	955AA1	PAINTED DISC WHEELS, REAR	WITHOUT PAINT	0	0	0
S	952AA1	SPOKE WHEELS-FRONT	WITHOUT OPTIONAL SPOKE WHEEL PAINT	0	0	0
S	953AA1	SPOKE WHEELS-REAR	WITHOUT OPTIONAL SPOKE WHEEL PAINT	0	0	0
S	962032	HUBS & DRUMS-FRONT	SAME AS CHASSIS RUNNING GEAR	0	0	0
S	963033	HUBS & DRUMS-REAR	SAME AS CHASSIS RUNNING GEAR	0	0	0

			WEIGHT (LB)		LIST PRICE	
CALCULATED CODES - KAX			FRONT	REAR		
		DESCRIPTION				
S	9JXA1X	PROPCALC SELECTION	YES, THE ORDER MUST BE CALCULATED	0	0	0
	D5EA1X	AUTO ROUTING & CLIPPING, CENTER	AUTOMATIC ROUTING & CLIPPING PLACEMENT, CENTER SECTION	0	0	0

TECHNICAL SPECIFICATION (cont.)

BASE WARRANTY & PURCHASED COVERAGES			DESCRIPTION	WEIGHT (LB)		LIST PRICE
				FRONT	REAR	
S	898003	VEHICLE WARRANTY TYPE	HEAVY DUTY WARRANTY CLASSIFICATION	0	0	0
S	M50030	BASIC CHASSIS COVERAGE	HEAVY DUTY STANDARD BASE COVERAGE 12 MONTHS/100,000 MILES (161,000 KM)	0	0	0
S	M51021	ENGINE WARRANTY	MACK MP7/MP8 BASE ENGINE COVERAGE 24 MONTHS / 250,000 MILES (402,000KM)	0	0	0
S	M52022	EMISSION COMPONENT COVERAGE	US and CANADA EQUIPPED VEHICLE EMISSION COMPONENTS COVERAGE 60 MONTHS/100,000 MILES (161,000 KM)	0	0	0
	M540B4	TRANSMISSION WARRANTY	ALLISON TRANSMISSIONS (Contact Allison Transmission for standard warranty and extended coverage data)	0	0	0
S	M55035	CARRIER & AXLE HOUSING WARRANTY	STANDARD MACK HEAVY DUTY COVERAGE 36 MONTHS / 350,000 (563,000 KM)	0	0	0
S	M56026	AIR CONDITIONING WARRANTY	AIR CONDITIONING STANDARD COVERAGE (Sealed System Only) 12 MONTHS UNLIMITED MILEAGE	0	0	0
S	M57027	CHASSIS TOWING WARRANTY	STANDARD NORMAL / HEAVY DUTY CHASSIS TOWING 90 DAYS OR 5,000 MILES	0	0	0
S	M58028	ENGINE TOWING WARRANTY	STANDARD MACK ENGINE TOWING COVERAGE 24 MONTHS/250,000 MILES (402,000 KM)	0	0	0
S	M690F9	GUARDDOG CONNECT BUNDLE	24 MONTH - GUARDDOG CONNECT WITH MACK OTA (with ASIST and Mack OneCall)	0	0	0
S	M67017	PREMIUM MAINTENANCE - CHASSIS LUBE AND INSPECTION	W/O PREMIUM MAINTENANCE - CHASSIS LUBE AND INSPECTION COVERAGE	0	0	0

ADDITIONAL ENGINEERING (NonApproved)		DESCRIPTION	WEIGHT (LB)		LIST PRICE
			FRONT	REAR	
CA	1		0	0	0

FRONT / REAR AXLE WEIGHTS (LB)

9882 8056

TOTAL WEIGHT (LB)

17,937

VEHICLE SPECIFICATION/CALCULATED PERFORMANCE SUMMARY

Description	Sales Code	Dwg Ref	Length	UOM
Front Frame Extension	N/A	FE	20.0	INCHES
Bumper to Front Axle	N/A	BA	29.0	INCHES
Wheelbase	N/A	WB	216.3	INCHES
Rear Overhang	N/A	OH	67.3	INCHES
Overall Length	N/A	OL	312.7	INCHES
Bumper to Back of Cab	N/A	BBC	116.5	INCHES
Eff. Bumper to Back of Cab	N/A	EBBC	116.5	INCHES
Eff. Cab to Rear Axle	N/A	ECA	128.8	INCHES
Eff. Front Axle to Back of Cab	N/A	EAC	87.5	INCHES
Eff. Cab to End of Frame	N/A	ECEF	196.1	INCHES
Unladen 5th Wheel Height	E5BZ1X	5W	0.0	INCHES
Unladen Frame Height	N/A	FH	44.8	INCHES
Cab Height	N/A	CH	70.9	INCHES
Overall Height	N/A	OVH	118.8	INCHES
Driver CG	N/A	DCG	70.9	INCHES
50" AXLE SPACING (BOGIE WHEELBASE)	GWXABX	BS	50.0	INCHES
Second Front Axle Spacing	RHXZ1X	SFAS	0.0	INCHES

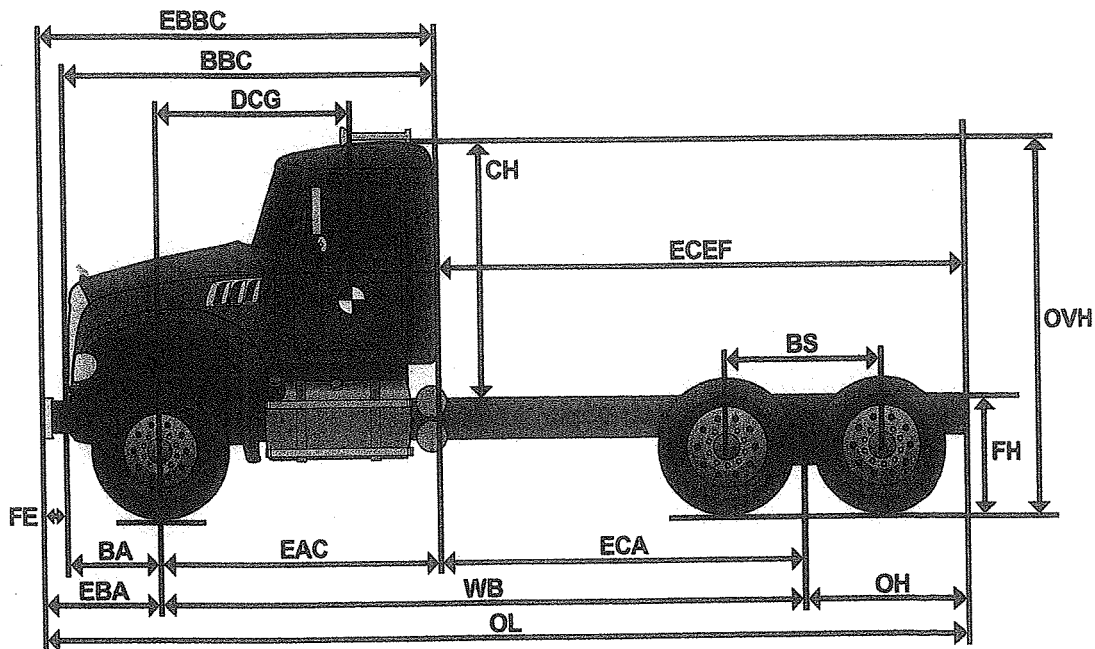

VEHICLE SPECIFICATION/CALCULATED PERFORMANCE SUMMARY				
Sub-Category	Sales Code	Sales Code Description	Value	UOM
Front Axle	240AA3	20000# (9100 KG) MACK FXL20 WIDE PIVOT CENTER STRAIGHT SPINDLE/UNITIZED BEARINGS	20000	LB
Front Suspension	244AC3	MACK MULTILEAF 20000# (9100 KG) GROUND LOAD RATING	20000	LB
Front Tires	900AZ6	315/80R22.5 L MICHELIN XZUS2 (20000 lbs)	20000	LB
Front Wheels	531AE4	22.5x9.00 HAYES LEMMERZ STEEL DISC 10-HOLE HUB PILOTED, FIVE HAND HOLE (11 1/4"/286mm BC)6.42" INSET	20001	LB
		Front GAWR	20000	LB
Rear Axle	268AA9	46000# (20900kg) MACK S462R CAST DUCTILE HOUSING	46001	LB
Rear Suspension	1860K6	SS462 MACK MULTILEAF (CAMELBACK) 46000# - EXTRA THICK SPRING THICKNESS	46001	LB
Rear Tires	901BG3	12R22.5 H MICHELIN XDN2 (27120 lbs) (DRIVE ONLY)	54234	LB
Rear Wheels	346AE8	22.5x9.00 HAYES LEMMERZ STEEL DISC 10-HOLE HUB PILOTED, FIVE HAND HOLE (11 1/4"/286 mm BC)	80002	LB
		Rear GAWR	46001	LB
		Truck GVWR	66000	LB
		Gross Combination Weight Rating	0	LB

13D



HIGHWAY DEPARTMENT

90 GARDNERTOWN ROAD
NEWBURGH, NEW YORK 12550

TELEPHONE 845-561-2177
FAX 845-561-8987

MARK HALL
HIGHWAY SUPERINTENDENT

TO: Gil Piaquadio, Supervisor, & Town Board Members

FROM: Mark Hall, Highway Superintendent *MH*

DATE: January 21, 2020

RE: Super Cabs

I am requesting permission to order new super cab. The bid price is \$68,681.42 we will be piggybacking from the Onondaga Bid quotes # 26945 the specifications are attached. We are looking at the Ford 450, super cab with plow. We are transitioning to Gas vehicles for additional savings. This will be taken from Highway Equipment/Other Capital Account # 030.5130.0200.

If you have any questions feel free to contact me. Thank you.

MH:ch
cc: Ron Clum, Accounting

Wednesday January 15th, 2020 12:14 PM



71 Marsh Rd East Rochester, NY 14445 585-586-7705 Fax 585-586-7706

Vehicle Purchase Proposal

Attention: George Woolsey

Purchase Order#:

Town of Newburgh
 88 Gardnertown Rd
 Newburgh NY12550
 Phone: 845-561-2288 Fax: 845-561-3975
 Email: fleetmaintenance@townofnewburgh.org

Quote# 30329

Onondaga Bid ONGOV-016-19 2020

Item Description	Code	Qty	Your Price	MSRP
2020 Ford F-450 XL Crew Cab 4x4 DRW 179 WB 60 CA	W4H	1	\$ 37,366.62	\$ 47,510.00
Race Red	PQ	1	\$ 0.00	\$ 0.00
7.3L 2V DECVT NA PFI V8 Gas	99N	1	\$ 0.00	\$ 0.00
TorqShift Ten-Speed Automatic	44G	1	\$ 0.00	\$ 0.00
Cab Steps (w/ Super/Crew Chassis Cab)	18B	1	\$ 400.50	\$ 445.00
Cloth 40/20/40 Split Bench - (XL Only) (Super Crew)	1S	1	\$ 283.50	\$ 315.00
Snow Plow Package	473	1	\$ 225.00	\$ 250.00
Spare Tire, Jack and Wheel	512	1	\$ 315.00	\$ 350.00
Cruise Control	525	1	\$ 211.50	\$ 235.00
TowCommand Integrated Trailer Brake Controller	52B	1	\$ 243.00	\$ 270.00
Transmission Power Take-Off Provision (Auto Trans only)	62R	1	\$ 252.00	\$ 280.00
Dual Extra Heavy-Duty Alternator	67B	1	\$ 103.50	\$ 115.00
Dual Batteries (78 Amp.) req. 7.3L Gas	86M	1	\$ 189.00	\$ 210.00
Power Equip Group on XL Only (Crew Cabs)	90L	1	\$ 1,012.50	\$ 1,125.00
Daytime Running Lamps (Fleet only)	942	1	\$ 40.50	\$ 45.00
LT225/70Rx19.5G BSW Traction (Six) (4x4)	TGK	1	\$ 193.50	\$ 215.00
Axle, Limited Slip 4.88 Ratio (6.8L)	X8L	1	\$ 324.00	\$ 360.00
Mud Flaps (Front Axle)		1	\$ 91.00	\$ 130.00
Cut Extra Holes for LED Strobes		1	\$ 140.00	\$ 200.00
LED Highlighter Mini Light Bar		1	\$ 694.40	\$ 992.00
Superior Signal LED Warning Strobe - Oval - Pair		1	\$ 540.40	\$ 772.00
Back-Up Alarm		1	\$ 147.00	\$ 210.00
Fisher 8' Poly Spreader 2.5 Yd		1	\$ 8,540.00	\$ 12,200.00
Hitch Plate w/ 8 Ton 2" Ball Pintle, D-rings, & 7-way plug		1	\$ 651.00	\$ 930.00
Spreader Tie Downs in Body		1	\$ 175.00	\$ 250.00
Spreader Worklights (2)		1	\$ 560.00	\$ 800.00
Central Grease Kit		1	\$ 339.50	\$ 485.00
Body-Up Warning Light Kit		1	\$ 175.00	\$ 250.00
Fisher 9' Steel HD Plow		1	\$ 6,265.00	\$ 8,950.00
Rugby DU9-4 Steel Dump Body SR4016, 1/4 Cab Shield w/ LED Light Kit, Painted		1	\$ 8,841.00	\$ 12,630.00
Cab Color, Undercoat Body				
Delivery to Region 5	Reg 5	1	\$ 362.00	\$ 362.00
Term is Net 15 Days A.R.V. Delivery from factory to dealer is estimated at 16-20 weeks. This Quote Expires in 60 Days or final Order date, whichever comes first.	Total Price:		\$ 68,681.42	
Quantity on this Order: 1	Grand Total:		\$ 68,681.42	

To place an order please sign and date this proposal and return it to Van Bortel Ford along with a valid Purchase Order, Voucher, or Letter of Intent. Thank You!

Accepted By: _____ Title _____ Date _____

13E



HIGHWAY DEPARTMENT

90 GARDNERTOWN ROAD
NEWBURGH, NEW YORK 12550

TELEPHONE 845-561-2177

FAX 845-561-8987

MARK HALL
HIGHWAY SUPERINTENDENT

TO: Gil Piaquadio, Supervisor & Town Board Members

FROM: Mark Hall, Highway Superintendent *MH*

DATE: January 21, 2020

RE: Summer Material and Other Bids

I would like to be put on the agenda, to go out to bid for the Summer Materials including Guide Rails, Chip Spreader, Wheel Rubber Tire Roller, and Aluminum Box Culverts. Also the individual bids for the Cold Milling Machine, Tree Cutting & Brush Grinding. The dates will be worked out with the Town Clerk's Office.

If you have any questions please feel free to call me. Thanking you in advance.

MH/ch
cc: Ron Clum, Accounting

13F



HIGHWAY DEPARTMENT

90 GARDNERTOWN ROAD
NEWBURGH, NEW YORK 12550

TELEPHONE 845-561-2177
FAX 845-561-8987

MARK HALL
HIGHWAY SUPERINTENDENT

TO: Gil Piaquadio, Supervisor & Town Board Members
FROM: Mark Hall, Highway Superintendent *MH*
DATE: January 21, 2020
RE: Truck Body's & Plows Bid

I would like to be put on the agenda, to go out to bid for a Truck Body & Plow for the Tandem Class 8 Truck. The dates will be worked out with the Town Clerk's Office.

If you have any questions please feel free to call me. Thanking you in advance.

MH/ch
cc: Ron Clum, Accounting

136

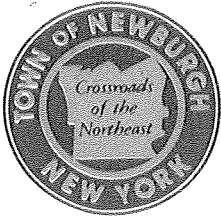

TOWN OF NEWBURGH

1496 ROUTE 300, NEWBURGH, NEW YORK 12550

845-564-4550

Assessor@TownofNewburgh.org

To: Town Supervisor ✓
Town Board

From: Charlene M Black, Personnel 

Date: January 22, 2020

Re: Full Time MEO 1A Position (2)

Mark Hall, Highway Superintendent is recommending the hiring of two full time MEO 1As. We had a posting that resulted in one name, Daniel Tartter, but turned down the position in favor of another one. Mr. Hall interviewed four candidates and he feels that James Mayen and Matthew Tubbs will be the right candidates to fill those positions at this time. Mr. Mayen and Mr. Tubbs will need to complete their paperwork, fingerprinting and CDL physical, with Drug / Alcohol testing . The intended start date will be on or after February 10, 2020. This salary will be per the CSEA contract.



HIGHWAY DEPARTMENT

90 GARDNERTOWN ROAD
NEWBURGH, NEW YORK 12550

TELEPHONE 845-561-2177

FAX 845-561-8987

MARK HALL
HIGHWAY SUPERINTENDENT

TO: Charlene Black, Personnel Department

FROM: Mark Hall, Highway Superintendent 

DATE: January 21, 2020

RE: Meo 1A Interviews

After interviewing the candidates for the position of MEO 1A with Jim Persutti, Charlene Black & myself we feel the following are the best qualified for the positions:

James Mayen
Matthew Tubbs

I am requesting that a start date on or about February 10 , 2020 Thank you.

MH:ch

TOWN OF NEWBURGH

EMPLOYMENT REQUEST FORM

To: Personnel Department

NAME OF CANDIDATE: JAMES MAYEN

DEPARTMENT: HIGHWAY

TITLE OF POSITION: MEOLA

FULL TIME OR PART TIME: FULL TIME

HOURLY RATE: \$ 22.8732

IS POSITION FUNDED IN CURRENT BUDGET: YES OR NO

FUND APPROPRIATION NUMBER: 5110.100

PROPOSED HIRE DATE: ON OR ABOUT FEBRUARY 10, 2020

NOTE: CANDIDATE CANNOT BEGIN WORK WITHOUT PRE-EMPLOYMENT PHYSICAL AND COMPLETION OF ALL REQUIRED PAPERWORK.

DEPARTMENT HEAD SIGNATURE

1/22/20
DATE

ORIGINAL APPLICATION SHOULD BE ON FILE IN THE PERSONNEL
DEPARTMENT

COPY TO ACCOUNTING DEPARTMENT
5-22-2017

TOWN OF NEWBURGH

EMPLOYMENT REQUEST FORM

To: Personnel Department

NAME OF CANDIDATE: MATTHEW Tubbs

DEPARTMENT: HIGHWAY

TITLE OF POSITION: MEO 1A

FULL TIME OR PART TIME: FULL TIME

HOURLY RATE: \$ 22.8732

IS POSITION FUNDED IN CURRENT BUDGET: YES OR NO

FUND APPROPRIATION NUMBER: 5110.100

PROPOSED HIRE DATE: ON OR ABOUT FEBRUARY 10, 2020

NOTE: CANDIDATE CANNOT BEGIN WORK WITHOUT PRE-EMPLOYMENT PHYSICAL AND COMPLETION OF ALL REQUIRED PAPERWORK.

DEPARTMENT HEAD SIGNATURE

1/22/20
DATE

ORIGINAL APPLICATION SHOULD BE ON FILE IN THE PERSONNEL
DEPARTMENT

COPY TO ACCOUNTING DEPARTMENT
5-22-2017

14A



TOWN OF NEWBURGH ANIMAL CONTROL &
SHELTER

645 GIDNEY AVE. NEWBURGH, NY 12550

(845)561-3344

FAX: (845) 561-2220

To: Town Board

From: Cheryl Cunningham, Animal Control

Subject: Authorization to pay Vet Services Utilizing T-94 Account

Date: December 27, 2019

I am requesting authorization to use the T-94 account to pay for Vet service: Newburgh Vet

Totaling: \$1535.55

Feline: \$195.60

Canine: \$1339.95

TOWN OF NEWBURGH

1496 Route 300
Newburgh, New York 12550
(845) 564-4552

DO NOT WRITE IN THIS BOX

DEPARTMENT _____

CLAIMANT'S
NAME
AND
ADDRESS

NEWBURGH VETERINARY HOSPITAL
1716 Route 300
Newburgh, NY 12550
Tel: (845) 564-2660
www.newburghvet.com

Date Voucher Received		VOUCHER NO. _____
FUND - APPROPRIATION	AMOUNT	
Total		
Abstract #		

TERMS Net 30 Days

Invoice # _____

Feline

Dates	Quantity	Description of Materials or Services	Unit Price	Amount
11/29/19	724549			19.00
12/6/19	725066			88.00
2/6/19	725067			88.00
			TOTAL	195.00

① int
② 4
③ 4

CLAIMANT'S CERTIFICATION

Dora M Cast certify that the above account in the amount of \$ 195.60 is true and correct; that the items, services and disbursements charged were rendered to or for the municipality on the dates stated; that no part has been paid or satisfied; that taxes, from which the municipality is exempt, are not included; and that the amount claimed is actually due.

12/26/19
DATE

Dora M Cast
SIGNATURE

Office Manager
TITLE

(Space below for municipal use)

DEPARTMENT APPROVAL

The above services or materials were rendered or furnished to the municipality on the dates stated and the charges are correct.

Date Authorized Official

APPROVAL FOR PAYMENT

This claim is approved and ordered for paid from the appropriations indicated above

Date Auditing Board

INVOICE

Newburgh Veterinary Hospital

1716 Route 300
Newburgh, NY 12550
845 564-2660

①

"Your pet is part of our family too." Visit us at www.newburghvet.com

FOR: Town of Newburgh - Feline
645 Gidney Ave.
Newburgh, NY 12550
(845) 561-3344

Printed: 12-27-19 at 10:37a
Date: 11-29-19
Account: 4417
Invoice: 724549

Date	For	Qty	Description	Price	Discount	Net Price
11-27-19	Alaska 40k-19	1	Centragard Red <5.5lbs (single do	28.55	18.95	9.60 **
11-27-19	Nebula 41k-19	1	Centragard Red <5.5lbs (single do	28.55	18.95	9.60 **
Total charges, this invoice...						19.20
**Total discount included: 37.90						

Your invoice total reflects our **13Stray Cat Accounts** discount.

LIKE US ON FACEBOOK.COM!

GOING AWAY?....BOOK YOUR PETS BOARDING RESERVATION TODAY!

In compliance with New York State law, all medications are non-refundable. We regret any inconveniences.

INVOICE

Newburgh Veterinary Hospital

1716 Route 300
Newburgh, NY 12550
845 564-2660



"Your pet is part of our family too." Visit us at www.newburghvet.com

FOR: Town of Newburgh - Feline
645 Gidney Ave.
Newburgh, NY 12550
(845) 561-3344

Printed: 12-06-19 at 4:29p
Date: 12-06-19
Account: 4417
Invoice: 725066

Date	For	Qty	Description	Price	Discount	Net Price
12-05-19	Nebula 41k-19	1	Weight Monitoring			0.00
12-06-19		1	Shelter board feline	16.90	8.45	8.45 ** ✓
12-06-19		0.06	BuprenorphineSR Inject/ml in hosp	34.38	34.38	0.00 **
12-06-19		0.20	Penicillin G Inject / ml (in hosp)	30.13	30.13	0.00 **
12-06-19		0.03	TelazolInject Control Log / ml			0.00
12-06-19		1	OHE FELINE	180.00	100.25	79.75 ** ✓
Your pet has been spayed. This eliminates the risk of uterine infection and lowers the risk of breast tumors when she gets older. Expect her to be quiet and not as active for a couple of days. Restrict exercise for the next two weeks. This receipt certifies that your pet has been spayed. Please keep this with your pet's health records.						
12-06-19		1	-Isoflurane Gas Anesthesia			0.00

Total charges, this invoice... 88.20

**Total discount included: 173.21

Your invoice total reflects our **13Stray Cat Accounts** discount.

Reminders for: **Nebula 41k-19** (Weight: 3.8 lbs - 11w) Last done

09/24	Consultation/Exam- Bi-annual
03/20	FECAL EXAM
01/20	Rabies/Purevax Feline 1yr
12/19	Rhinotracheitis/Pan/leuk/Calic

Doctor's Instructions

OHE FELINE

Your kitty has been surgically spayed. Please watch the incision for swelling or redness, and give antibiotics as indicated.

Nebula 41k-19's weight history (in lbs)

12-05-19	3.80
----------	------

INVOICE

Newburgh Veterinary Hospital

1716 Route 300
Newburgh, NY 12550
845 564-2660

3

"Your pet is part of our family too." Visit us at www.newburghvet.com

FOR: Town of Newburgh - Feline
645 Gidney Ave.
Newburgh, NY 12550
(845) 561-3344

Printed: 12-06-19 at 4:30p
Date: 12-06-19
Account: 4417
Invoice: 725067

Date	For	Qty	Description	Price	Discount	Net Price
12-05-19	Alaska 40k-19	1	Weight Monitoring			0.00
12-06-19		1	Shelter board feline	16.90	8.45	8.45 ** ✓
12-06-19		0.07	BuprenorphineSR Inject/ml in hosp	35.11	35.11	0.00 **
12-06-19		0.25	Penicillin G Inject / ml (in hosp)	30.16	30.16	0.00 **
12-06-19		0.04	TelazolInject Control Log / ml			0.00
12-06-19		1	OHE FELINE	180.00	100.25	79.75 ** ✓
Your pet has been spayed. This eliminates the risk of uterine infection and lowers the risk of breast tumors when she gets older. Expect her to be quiet and not as active for a couple of days. Restrict exercise for the next two weeks. This receipt certifies that your pet has been spayed. Please keep this with your pet's health records.						
12-06-19		1	-Isoflurane Gas Anesthesia			0.00

Total charges, this invoice... 88.20
**Total discount included: 173.97

Your invoice total reflects our **13Stray Cat Accounts** discount.

Reminders for: **Alaska 40k-19** (Weight: 4.5 lbs - 7w) Last done

10/24	Consultation/Exam- Bi-annual
04/20	FECAL EXAM
02/20	Rabies/Purevax Feline 1yr
01/20	Rhinotracheitis/Pan/leuk/Calic

Doctor's Instructions

OHE FELINE

Your kitty has been surgically spayed. Please watch the incision for swelling or redness, and give antibiotics as indicated.

Alaska 40k-19's weight history (in lbs)

12-05-19	4.50
----------	------

TOWN OF NEWBURGH

1496 Route 300
Newburgh, New York 12550
(845) 564-4552

DO NOT WRITE IN THIS BOX

DEPARTMENT _____

CLAIMANT'S
NAME
AND
ADDRESS

NEWBURGH VETERINARY HOSPITAL
1716 Route 300
Newburgh, NY 12550
Tel: (845) 564-2660
www.newburghvet.com

Date Voucher Received		VOUCHER NO.
FUND - APPROPRIATION	AMOUNT	
Total		
Abstract #		

TERMS Net 30 Days

Invoice # _____

Canine

Dates	Quantity	Description of Materials or Services	Unit Price	Amount
11/25/19	724258 ①			227.87
11/29/19	724551 ②			20.05
12/3/19	724822 ③			147.93
12/5/19	724969 ④			26.00
12/9/19	725248 ⑤			26.90
12/10/19	725331 ⑥			214.50
12/10/19	725332 ⑦			16.50
12/13/19	725599 ⑧			150.50
12/18/19	725917 ⑨			509.70
TOTAL				1339.95

① ✓
② ✓
③ ✓
④ ✓
⑤ ✓
⑥ ✓
⑦ ✓
⑧ ✓
⑨ ✓

CLAIMANT'S CERTIFICATION

I, Dora M Cast certify that the above account in the amount of \$ 1339.95 is true and correct; that the items, services and disbursements charged were rendered to or for the municipality on the dates stated; that no part has been paid or satisfied; that taxes, from which the municipality is exempt, are not included; and that the amount claimed is actually due.

12/26/19
DATE

Dora M Cast
SIGNATURE

Office Manager
TITLE

(Space below for municipal use)

DEPARTMENT APPROVAL

The above services or materials were rendered or furnished to the municipality on the dates stated and the charges are correct.

Date Authorized Official

APPROVAL FOR PAYMENT

This claim is approved and ordered for paid from the appropriations indicated above

Date Auditing Board

INVOICE

Newburgh Veterinary Hospital

1716 Route 300
 Newburgh, NY 12550
 845 564-2660

①

"Your pet is part of our family too." Visit us at www.newburghvet.com

FOR: Town of Newburgh - canine
 645 Gidney Ave
 Newburgh, NY 12550
 (845) 561-3344

Printed: 12-27-19 at 10:45a
Date: 11-25-19
Account: 19984
Invoice: 724258

Date	For	Qty	Description	Price	Discount	Net Price	
11-25-19	Buddy #93-19	1	Neuter/Canine- Town of Newburgh			79.75	✓
11-25-19		1	CANINE RABIES / 1YEAR	38.00	21.50	16.50	** ✓
11-25-19		1	Canine Dist/A2/PI/Parvo/Lepto1YR	39.00	24.50	14.50	** ✓
Your pet has been vaccinated with Pfizer's new 5 in 1 DA2PPI, the best available protection against Distemper, Adenovirus, Parvovirus, Parainfluenza, and Leptospirosis							
11-25-19		1	Canine Respiratory Complex- Bord	37.00	23.25	13.75	** ✓
Canine Kennel Cough is A HIGHLY contagious respiratory infection. Dogs can be exposed at any time through coughing or nose to nose contact. Boarding, grooming and or showing dogs can have increased risk of exposure....please be sure to have your pet boosted every 12 months.							
11-25-19		1	Accuplex4 Lyme, HW, Ehrlichia, Ana	72.00	46.00	26.00	** ✓
11-25-19		0.70	Hydromorphone 2mg/ml Inject/ml	37.77	37.77	0.00	**
11-25-19		2.50	Penicillin G Inject / ml (in hosp)	31.65	31.65	0.00	**
11-25-19		1	Vetprofen Tablets 100mg Individual	18.40	18.40	0.00	**
11-25-19		0.70	TelazolInject Control Log / ml			0.00	
11-25-19		1	Drontal dewormer 136 mg / tablet #	50.55	32.72	17.83	** ✓
11-25-19		1	Otic- Tresaderm 15ml #265397			42.50	✓
11-25-19		5	Vetprofen Tablets 100mg Individual	21.80	19.04	2.76	** ✓
11-25-19		14	Amoxicillin 250mg capsule #26539	20.07	5.79	14.28	** ✓

Total charges, this invoice...

227.87

**Total discount included: 260.62

OK

Your invoice total reflects our **13 Stray Cat Accounts** discount.

Reminders for: Buddy #93-19	Last done
11/22	Consultation/Exam- Bi-annual
11/20	CANINE RABIES / 3 YEAR
11/20	lyme, HW, Ehrlichia Accu Plus4(A)
11/20	CanineDist/Aden/Para/Parvo/Lep

INVOICE

Newburgh Veterinary Hospital

1716 Route 300
Newburgh, NY 12550
845 564-2660



"Your pet is part of our family too." Visit us at www.newburghvet.com

FOR: Town of Newburgh - canine
645 Gidney Ave
Newburgh, NY 12550
(845) 561-3344

Printed: 12-27-19 at 10:46a
Date: 11-29-19
Account: 19984
Invoice: 724551

Date	For	Qty	Description	Price	Discount	Net Price
11-27-19	Buddy #93-19	1	Pyrantel 16oz (TON) #265481	22.10	2.05	20.05 **
Total charges, this invoice...						20.05

**Total discount included: 2.05

Your invoice total reflects our **13Stray Cat Accounts** discount.

Reminders for: Buddy #93-19	Last done	
11/22	Consultation/Exam- Bi-annual	
11/20	CANINE RABIES / 3 YEAR	
11/20	lyme,HW,Ehrlichia Accu Plus4(A	11-25-19
11/20	CanineDist/Aden/Para/Parvo/Lep	
11/20	Canine Kennel Cough Vacc -1 ye	11-25-19
05/20	FECAL EXAM	
05/20	Neuter your pet at 5-6 months	
11/18	Pro-Heart 12 (1-25lb)	
11/18	Pro-Heart 12 (51-100lbs)	
11/18	Pro-Heart 12 (26-50lbs)	

LIKE US ON FACEBOOK.COM!

GOING AWAY?...BOOK YOUR PETS BOARDING RESERVATION TODAY!

In compliance with New York State law, all medications are non-refundable. We regret any inconveniences.

INVOICE

Newburgh Veterinary Hospital

1716 Route 300
Newburgh, NY 12550
845 564-2660

3

"Your pet is part of our family too." Visit us at www.newburghvet.com

FOR: Town of Newburgh - canine
645 Gidney Ave
Newburgh, NY 12550
(845) 561-3344

Printed: 12-26-19 at 10:22a
Date: 12-03-19
Account: 19984
Invoice: 724822

Date	For	Qty	Description	Price	Discount	Net Price	
12-03-19	Prince #99-19	1	CONSULT / EXAM - Sick	69.50	38.25	31.25	** ✓
12-03-19		1	Fecal Analysis w/ Pathology revie	70.00	35.00	35.00	** ✓
12-03-19		1	Lyme,Hwt,Ehrlich Anaplasma 4Dx i	110.00	69.75	40.25	** ✓
12-03-19		0.60	Rimadyl Inject / ml Outpatient	25.29	12.65	12.64	** ✓
12-03-19		0.50	Unasyn Inject / ml (outpatient)	32.00	16.00	16.00	** ✓
12-03-19		15	Pro Pectalin Tabs #265686	24.75	21.87	2.88	** ✓
12-03-19		7	Metronidazole 250mg. #265702	20.00	18.49	1.51	** ✓
12-03-19		28	Amoxicillin 100mg tab #265703	32.67	26.62	6.05	** ✓
12-03-19		7	Vetprofen Tablets 25mg Individual	21.96	19.61	2.35	** ✓

Total charges, this invoice...

147.93

**Total discount included: 258.24

dc

Your invoice total reflects our **13Stray Cat Accounts** discount.

LIKE US ON FACEBOOK.COM!

GOING AWAY?....BOOK YOUR PETS BOARDING RESERVATION TODAY!

In compliance with New York State law, all medications are non-refundable. We regret any inconveniences.

INVOICE

Newburgh Veterinary Hospital

1716 Route 300
Newburgh, NY 12550
845 564-2660



"Your pet is part of our family too." Visit us at www.newburghvet.com

FOR: Town of Newburgh - canine
645 Gidney Ave
Newburgh, NY 12550
(845) 561-3344

Printed: 12-05-19 at 2:54p
Date: 12-05-19
Account: 19984
Invoice: 724969

Date	For	Qty	Description	Price	Discount	Net Price
12-05-19	Zima #97-19	1	Accuplex4 Lyme,HW,Ehrlichia,Ana	72.00	36.00	36.00 **
Total charges, this invoice...						36.00
**Total discount included: 36.00						26.00

Your invoice total reflects our **13Stray Cat Accounts** discount.

Reminders for: Zima #97-19	Last done	
12/22	Consultation/Exam- Bi-annual	
12/20	lyme,HW,Ehrlichia Accu Plus4(A)	12-05-19
06/20	Canine Kennel Cough Vacc -1 ye	
06/20	FECAL EXAM	
12/18	Pro-Heart 12 (26-50lbs)	
12/18	Pro-Heart 12 (1-25lb)	
12/18	Pro-Heart 12 (51-100lbs)	
04/18	CANINE RABIES / 1YEAR	

Reminders for: Prince #99-19 (Weight: 17.3 lbs - 18m)	Last done	
06/23	Consultation/Exam- Bi-annual	
12/20	lyme,HW,Ehrlichia Accu Plus4(A)	12-03-19
06/20	Neuter your pet at 5-6 months	
06/20	Canine Kennel Cough Vacc -1 ye	
06/20	FECAL EXAM	12-03-19
06/19	Pro-Heart 12 (26-50lbs)	
06/19	Pro-Heart 12 (1-25lb)	
06/19	Pro-Heart 12 (51-100lbs)	
10/18	CANINE RABIES / 1YEAR	

LIKE US ON FACEBOOK.COM!

INVOICE

Newburgh Veterinary Hospital

1716 Route 300
Newburgh, NY 12550
845 564-2660

5

"Your pet is part of our family too." Visit us at www.newburghvet.com

FOR: Town of Newburgh - canine
645 Gidney Ave
Newburgh, NY 12550
(845) 561-3344

Printed: 12-26-19 at 10:20a
Date: 12-09-19
Account: 19984
Invoice: 725248

Date	For	Qty	Description	Price	Discount	Net Price
12-06-19	Buddy #93-19	40	Trazodone 100mg tablets #265823	27.55	23.85	3.70 ***
12-06-19		4	DMSO Solution / oz #265824	51.55	50.35	1.20 **
12-06-19		1	CONSULT / EXAM - Medical progr	57.00	35.00	22.00 *
12-06-19		1	Pet Insurance Review			0.00

Please visit www.petinsurancereview.com and dogtime.com for an independent review of all national pet health insurance plans

Total charges, this invoice... 26.90

**Total discount included: 109.20

Your invoice total reflects our **13Stray Cat Accounts** discount.

LIKE US ON FACEBOOK.COM!

GOING AWAY?...BOOK YOUR PETS BOARDING RESERVATION TODAY!

In compliance with New York State law, all medications are non-refundable. We regret any inconveniences.

INVOICE

Newburgh Veterinary Hospital

1716 Route 300
Newburgh, NY 12550
845 564-2660

(4)

"Your pet is part of our family too." Visit us at www.newburghvet.com

FOR: Town of Newburgh - canine
645 Gidney Ave
Newburgh, NY 12550
(845) 561-3344

Printed: 12-11-19 at 10:10a
Date: 12-10-19
Account: 19984
Invoice: 725331

Date	For	Qty	Description	Price	Discount	Net Price
12-09-19	Buddy #93-19	1	CONSULT / EXAM - Followup	44.00	22.00	22.00**
12-09-19		1	Pet Insurance Review			0.00
Please visit www.petinsurancereview.com and dogtime.com for an independent review of all national pet health insurance plans						
12-09-19		0.70	Hydromorphone 2mg/ml Inject/ml	37.77	37.77	0.00**
12-10-19		1	Scrotal Ablation with neuter			150.00✓
12-10-19		1	Anesthesia- Isoflurane	260.00	260.00	0.00**
12-10-19		1	---BloodPressureMonitoring w/anes			0.00
12-10-19		1	---PulseOximeterMonitoring w/Anes			0.00
12-10-19		1	-CapnographMonitoring w/Anesthe			0.00
12-10-19		1	----Recovery in Heated Cage			0.00
12-10-19		1	----Warm Water Blanket in Surgery			0.00
12-10-19		0.70	Hydromorphone 2mg/ml Inject/ml	37.77	37.77	0.00**
12-10-19		2.50	Penicillin G Inject / ml Outpatient	31.45	31.45	0.00**
12-10-19		1	Vetprofen Tablets 100mg Individual	18.40	18.40	0.00**
12-10-19		0.50	TelazolInject Control Log / ml			0.00
12-10-19		1	Otic- Tresaderm 15ml			42.50✓

Total charges, this invoice...

**Total discount included: 407.39

214.50

Your invoice total reflects our **13Stray Cat Accounts** discount.

Reminders for: Buddy #93-19	Last done
11/22 Consultation/Exam- Bi-annual	
11/20 CANINE RABIES / 3 YEAR	
11/20 lyme,HW,Ehrlichia Accu Plus4(A	11-25-19
11/20 CanineDist/Aden/Para/Parvo/Lep	
11/20 Canine Kennel Cough Vacc -1 ye	11-25-19
05/20 FECAL EXAM	
05/20 Neuter your pet at 5-6 months	
11/18 Pro-Heart 12 (1-25lb)	

Ou

INVOICE

Newburgh Veterinary Hospital

1716 Route 300
Newburgh, NY 12550
845 564-2660

⑦

"Your pet is part of our family too." Visit us at www.newburghvet.com

FOR: Town of Newburgh - canine
645 Gidney Ave
Newburgh, NY 12550
(845) 561-3344

Printed: 12-10-19 at 2:20p
Date: 12-10-19
Account: 19984
Invoice: 725332

Date	For	Qty	Description	Price	Discount	Net Price
12-10-19	Dutchess 102-19	1	CANINE RABIES / 3 YEAR	38.00	19.00	19.00 **

Total charges, this invoice...

18.00

**Total discount included: 19.00

16.50
de

Your invoice total reflects our **13Stray Cat Accounts** discount.

Reminders for: Dutchess 102-19	Last done
12/22 CANINE RABIES / 3 YEAR	12-10-19
12/22 Consultation/Exam- Bi-annual	
06/20 Spay your pet at 5-6 months	
06/20 Canine Kennel Cough Vacc -1 ye	
06/20 FECAL EXAM	
12/18 Pro-Heart 12 (26-50lbs)	
12/18 Pro-Heart 12 (1-25lb)	
12/18 Pro-Heart 12 (51-100lbs)	
06/18 HEARTWORM TEST	

LIKE US ON FACEBOOK.COM!

GOING AWAY?...BOOK YOUR PETS BOARDING RESERVATION TODAY!

In compliance with New York State law, all medications are non-refundable. We regret any inconveniences.

INVOICE

Newburgh Veterinary Hospital

1716 Route 300
Newburgh, NY 12550
845 564-2660



"Your pet is part of our family too." Visit us at www.newburghvet.com

FOR: Town of Newburgh - canine
645 Gidney Ave
Newburgh, NY 12550
(845) 561-3344

Printed: 12-13-19 at 3:54p
Date: 12-13-19
Account: 19984
Invoice: 725599

Date	For	Qty	Description	Price	Discount	Net Price
12-13-19	Stu Lu Who #99-	1	Weight Monitoring			0.00
12-13-19		1	Neuter/Canine- Town of Newburgh			79.75 ✓
12-13-19		1	Anesthesia- Isoflurane	260.00	260.00	0.00 **
12-13-19		1	---BloodPressureMonitoring w/anes			0.00
12-13-19		1	---PulseOximeterMonitoring w/Anes			0.00
12-13-19		1	-CapnographMonitoring w/Anesthe			0.00
12-13-19		1	----Recovery in Heated Cage			0.00
12-13-19		1	----Warm Water Blanket in Surgery			0.00
12-13-19		0.20	Hydromorphone 2mg/ml Inject/ml	32.22	32.22	0.00 **
12-13-19		0.70	Penicillin G Inject / ml Outpatient	30.40	30.40	0.00 **
12-13-19		1	Vetprofen Tablets 25mg Individual	18.18	18.18	0.00 **
12-13-19		0.10	TelazolInject Control Log / ml			0.00
12-13-19		1	Accuplex4 Lyme,HW,Ehrlichia,Ana	72.00	46.00	26.00 ✓
12-13-19		1	Canine Respiratory Complex- Bord	37.00	23.25	13.75 ** ✓
<p>Canine Kennel Cough is A HIGHLY contagious respiratory infection. Dogs can be exposed at any time through coughing or nose to nose contact. Boarding, grooming and or showing dogs can have increased risk of exposure....please be sure to have your pet boosted every 12 months.</p>						
12-13-19		1	CANINE RABIES / 1YEAR	38.00	21.50	16.50 ** ✓
12-13-19		1	Canine Dist/A2/PI/Parvo/Lepto1YR	39.00	24.50	14.50 ** ✓

Your pet has been vaccinated with Pfizer's new 5 in 1 DA2PPI , the best available protection against Distemper, Adenovirus, Parvovirus, Parainfluenza, and Leptosiprosis

Total charges, this invoice...
**Total discount included: 456.05

150.50

ole

Your invoice total reflects our **13Stray Cat Accounts** discount.

Reminders for: **Stu Lu Who #99-19** (Weight: 13.0 lbs - 18 Last done

06/23 Consultation/Exam- Bi-annual

INVOICE

Newburgh Veterinary Hospital

1716 Route 300
Newburgh, NY 12550
845 564-2660



"Your pet is part of our family too." Visit us at www.newburghvet.com

FOR: Town of Newburgh - canine
645 Gidney Ave
Newburgh, NY 12550
(845) 561-3344

Printed: 12-18-19 at 11:58a
Date: 12-18-19
Account: 19984
Invoice: 725917

Date	For	Qty	Description	Price	Discount	Net Price
12-17-19	Cindu Lu Who #9	1	Weight Monitoring			0.00
12-17-19		1	Nictitans Gl.Prolapse/Excise-Bilater	550.00	275.00	275.00 ** ✓
12-17-19		1	OHE Canine - Town of Newburgh			99.75 ✓
12-17-19		1	Anesthesia- Isoflurane	260.00	260.00	0.00 **
12-17-19		1	---BloodPressureMonitoring w/anes			0.00
12-17-19		1	---PulseOximeterMonitoring w/Anes			0.00
12-17-19		1	-CapnographMonitoring w/Anesthe			0.00
12-17-19		1	----Recovery in Heated Cage			0.00
12-17-19		1	----Warm Water Blanket in Surgery			0.00
12-17-19		0.20	Hydromorphone 2mg/ml Inject/ml	32.22	32.22	0.00 **
12-17-19		0.70	Penicillin G Inject / ml Outpatient	30.40	30.40	0.00 **
12-17-19		1	Vetprofen Tablets 25mg Individual	18.18	18.18	0.00 **
12-17-19		0.15	TelazolInject Control Log / ml			0.00
12-17-19		1	Accuplex4 Lyme,HW,Ehrlichia,Ana	72.00	46.00	26.00 ** ✓
12-17-19		1	Canine Respiratory Complex- Bord	37.00	23.25	13.75 ** ✓
<p>Canine Kennel Cough is A HIGHLY contagious respiratory infection. Dogs can be exposed at any time through coughing or nose to nose contact. Boarding, grooming and or showing dogs can have increased risk of exposure....please be sure to have your pet boosted every 12 months.</p>						
12-17-19		1	Canine Dist/A2/PI/ParvoYR	39.00	24.50	14.50 ** ✓
<p>Your pet has been vaccinated with Pfizer's new 5 in 1 DA2PPI , the best available protection against Distemper,Adenovirus, Parvovirus, Parainfluenza,and Leptosiprosis</p>						
12-17-19		1	CANINE RABIES / 1YEAR	38.00	21.50	16.50 ** ✓
12-17-19		1	Elizabethan Collar	20.00	2.00	18.00 ** ✓
12-17-19		1	Shelter board medical alert k9	51.50	25.75	25.75 ** ✓
12-18-19		1	Ophth- Tobramycin Suspension #2	39.99	29.54	10.45 ** ✓
12-18-19		4	Cefpodoxime 100mg* #266271	22.19	17.19	5.00 ** ✓
12-18-19		5	Vetprofen Tablets 25mg Individual	20.70	15.70	5.00 ** ✓

Total charges, this invoice...

509.70

**Total discount included: 821.23

Your invoice total reflects our **13Stray Cat Accounts** discount.



14B

TOWN OF NEWBURGH ANIMAL CONTROL &
SHELTER

645 GIDNEY AVE. NEWBURGH, NY 12550

(845)561-3344
FAX: (845) 561-2220

To: Town Board

From: Cheryl Cunningham, Animal Control

Subject: Authorization to pay Vet Services Utilizing T-94 Account

Date: December 31, 2019

I am requesting authorization to use the T-94 account to pay for Vet service: Newburgh Vet

Totaling: \$44.00

Feline: \$

Canine: \$

Other: \$44.00

TOWN OF NEWBURGH

1496 Route 300
Newburgh, New York 12550
(845) 564-4552

DEPARTMENT _____

CLAIMANT'S
NAME
AND
ADDRESS

NEWBURGH VETERINARY HOSPITAL
1716 Route 300
Newburgh, NY 12550
Tel: (845) 564-2660
www.newburghvet.com

DO NOT WRITE IN THIS BOX

Date Voucher Received		VOUCHER NO.
FUND - APPROPRIATION	AMOUNT	
Total		
Abstract #		

TERMS Net 30 Days

Invoice # _____

Other

Dates	Quantity	Description of Materials or Services	Unit Price	Amount
2/5/19	724968			22.00
2/21/19	726132			22.00
			TOTAL	44.00

CLAIMANT'S CERTIFICATION

Doram Cast certify that the above account in the amount of \$ 44.00 is true and correct; that the items, services and disbursements charged were rendered to or for the municipality on the dates stated; that no part has been paid or satisfied; that taxes, from which the municipality is exempt, are not included; and that the amount claimed is actually due.

12/30/19
DATE

Doram Cast
SIGNATURE

Office Mgr
TITLE

(Space below for municipal use)

DEPARTMENT APPROVAL

The above services or materials were rendered or furnished to the municipality on the dates stated and the charges are correct.

Date

Authorized Official

APPROVAL FOR PAYMENT

This claim is approved and ordered for paid from the appropriations indicated above

Date

Auditing Board

INVOICE

Newburgh Veterinary Hospital

1716 Route 300
Newburgh, NY 12550
845 564-2660

"Your pet is part of our family too." Visit us at www.newburghvet.com

FOR: Town of Newburgh - Other
645 Gidney Ave.
Newburgh, NY 12550
(845) 561-3344

Printed: 12-31-19 at 2:54p
Date: 12-05-19
Account: 25745
Invoice: 724968

Date	For	Qty	Description	Price	Discount	Net Price
12-05-19	Noah	1	applied second half of revolution			0.00
12-05-19		1	Veterinarian's Notes			0.00
12-05-19		1	CONSULT / EXAM - Followup	44.00	22.00	22.00 **

Total charges, this invoice...

**Total discount included: 22.00

22.00

Your invoice total reflects our **13Stray Cat Accounts** discount.

Reminders for: **Noah** (Weight: 908.0 g - 13m) Last done

05/20 Consult/Pocket Pet
11/19 **CONSULT/EXAM - Annual Wellness**

LIKE US ON FACEBOOK.COM!

GOING AWAY?...BOOK YOUR PETS BOARDING RESERVATION TODAY!

In compliance with New York State law, all medications are non-refundable. We regret any inconveniences.

INVOICE

Newburgh Veterinary Hospital

1716 Route 300
Newburgh, NY 12550
845 564-2660

"Your pet is part of our family too." Visit us at www.newburghvet.com

FOR: Town of Newburgh - Other
645 Gidney Ave.
Newburgh, NY 12550
(845) 561-3344

Printed: 12-31-19 at 2:54p
Date: 12-21-19
Account: 25745
Invoice: 726132

Date	For	Qty	Description	Price	Discount	Net Price
12-20-19	Noah	1	CONSULT / EXAM - Followup	44.00	22.00	22.00 **
12-20-19		1	Pet Insurance Review			0.00

Please visit www.petinsurancereview.com and dogtime.com for an independent review of all national pet health insurance plans

Total charges, this invoice...
**Total discount included: 22.00

22.00

Your invoice total reflects our **13Stray Cat Accounts** discount.

Reminders for:	Noah (Weight: 908.0 g - 13m)	Last done
05/20	Consult/Pocket Pet	
11/19	CONSULT/EXAM - Annual Wellness	

LIKE US ON FACEBOOK.COM!

GOING AWAY?...BOOK YOUR PETS BOARDING RESERVATION TODAY!

In compliance with New York State law, all medications are non-refundable. We regret any inconveniences.

14C

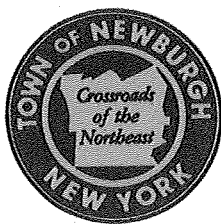

TOWN OF NEWBURGH ANIMAL CONTROL &
SHELTER

645 GIDNEY AVE. NEWBURGH, NY 12550

(845)561-3344

FAX: (845) 561-2220

To: Town Board

From: Cheryl Cunningham, Animal Control

Subject: Authorization to pay Services Utilizing T-94 Account

Date: January 9, 2020

I am requesting authorization to use the T-94 account to pay for service: Walden Humane Society

Totaling: \$100.00

Feline: \$

Canine: \$100.00

TOWN OF NEWBURGH

1496 Route 300
Newburgh, New York 12550
(845) 564-5220

H02880

DO NOT WRITE IN THIS BOX

DEPARTMENT _____

CLAIMANT'S
NAME
AND
ADDRESS

Humane Society of Warden
2489 Albany Post Rd
Walden N.Y. 12586

Date Voucher Received		VOUCHER NO.
FUND - APPROPRIATION	AMOUNT	
Total		
Abstract #		

TERMS Net 30 Days

Invoice # _____

Dates	Quantity	Description of Materials or Services	Unit Price	Amount
11/14/19 11/14/19	1	make pit mix "Diesel" transferred to HSW 11/14/19 owner surrender Wilbert Cobbs	\$100-	\$100-
TOTAL				100

CLAIMANT'S CERTIFICATION

I, Cait Calderin certify that the above account inf the amount of \$ 100 is true

and correct; that the items, services and disbursements charged were rendered to or for the municipality on the dates stated; that no part has been paid or satisfied; that taxes, from which the municipality is exempt, are not included; and that the amount claimed is actually due.

12/29/19
DATE

[Signature]
SIGNATURE

Shelter Manager
TITLE

(Space below for municipal use)

DEPARTMENT APPROVAL

The above services or materials were rendered or furnished to the municipality on the dates stated and the charges are correct.

Date

Authorized Official

APPROVAL FOR PAYMENT

This claim is approved and ordered for paid from the appropriations indicated above

Date

Auditing Board

14D

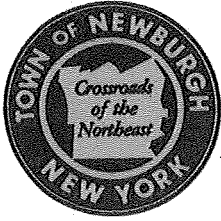

TOWN OF NEWBURGH ANIMAL CONTROL &
SHELTER

645 GIDNEY AVE. NEWBURGH, NY 12550

(845)561-3344
FAX: (845) 561-2220

To: Town Board

From: Cheryl Cunningham, Animal Control

Subject: Authorization to pay Vet Services Utilizing T-94 Account

Date: January 15, 2020

I am requesting authorization to use the T-94 account to pay for Vet service: Flannery Animal Hospital

Totaling: \$98.55

Feline: \$

Canine: \$98.55



VCA Flannery Animal Hospital PC

789 Little Britain Rd. | New Windsor, NY 12553 | (845) 565 - 7387

Dr. Winter | Date: 1/7/2020 at 06:39 | Invoice: 834872708 | Cashier: Jean T

Client

Town Of Newburgh 2020 Animal Control (#54239)

645 Gidney Ave
Newburgh, NY 12550

Patient

Bandit (#431)

Species: Canine (Shepherd Dog, German)

Sex: Male Neutered | Color: Brown

Birth: 07/01/2010 | Age: 9y 6m | Weight: 73.2 lb

Detailed Visit Information

Date	Description	Qty	Price	Discount	Tax	Total Price
1/4/2020	Boarding Animal Control	1.00	\$30.00	-\$2.25	\$2.25	\$30.00
1/5/2020	Boarding Animal Control	1.00	\$30.00	-\$2.25	\$2.25	\$30.00
1/6/2020	Boarding Go Home Day	1.00	\$0.00		\$0.00	\$0.00

Subtotal: \$60.00

30.00

Discounts	Shelters/PetStore	- \$4.50
-----------	-------------------	----------

Preventive Care Status for Bandit (Please check for accuracy)

Procedure	Due Date	Status	Procedure	Due Date	Status
K9 Flea Prevention	11/13/2019	Overdue			

Invoice Summary

Patient Name	Total Price	Total Discount	Total Tax	Total Due
Bandit	\$60.00	-\$4.50	\$4.50	\$60.00

	Total Due:	\$60.00
--	------------	---

\$ 30.00

For information on how we collect and use information about you and your pet, and how you may opt-out of some uses, please see our Privacy Policy at vcahospitals.com/privacy-policy.

Thank you for trusting us with your pet's care. Your friends at VCA Flannery Animal Hospital PC.



Dr. Winter | Date: 1/7/2020 at 06:36 | Invoice: 834872707 | Cashier: Jean T

Client

Town Of Newburgh 2020 Animal Control (#54239)

645 Gidney Ave
Newburgh, NY 12550

Patient

Emmy (#433)

Species: Canine (Hound Mix)

Sex: Female Spayed | Color: Tan

Birth: 12/20/2016 | Age: 3y | Weight: 83.5 lb

Detailed Visit Information

Date	Description	Qty	Price	Discount	Tax	Total Price
1/4/2020	Boarding Animal Control	1.00	\$30.00	-\$2.25	\$2.25	\$30.00
1/5/2020	Boarding Go Home Day	1.00	\$0.00		\$0.00	\$0.00

Subtotal: \$30.00

Discounts	Shelters/PetStore	-\$2.25
-----------	-------------------	---------

Preventive Care Status for Emmy (Please check for accuracy)

Procedure	Due Date	Status	Procedure	Due Date	Status
K9 Flea Prevention	6/20/2019	Overdue			

Invoice Summary

Patient Name	Total Price	Total Discount	Total Tax	Total Due
Emmy	\$30.00	-\$2.25	\$2.25	\$30.00

	Prev Balance:	\$0.00
	Total Due:	\$30.00
	Amount Paid:	\$0.00
	Amount Due:	\$30.00

For information on how we collect and use information about you and your pet, and how you may opt-out of some uses, please see our Privacy Policy at vcahospitals.com/privacy-policy.

Thank you for trusting us with your pet's care. Your friends at VCA Flannery Animal Hospital PC.



VCA Flannery Animal Hospital PC
789 Little Britain Rd. | New Windsor, NY 12553 | (845) 565 - 7387

Dr. Keller | Date: 1/7/2020 at 08:48 | Invoice: 834872719 | Cashier: Jean T

Client

Town Of Newburgh 2020 Animal Control (#54239)

645 Gidney Ave
Newburgh, NY 12550

Patient

2020-1-1-Chocolate Lab (#126205)
Species: Canine (Retriever, Labrador)
Sex: Female Spayed | Color: Chocolate
Birth: 07/01/2018 | Age: 1y 6m | Weight: 61.5 lb

Detailed Visit Information

Date	Description	Qty	Price	Discount	Tax	Total Price
1/1/2020	Capstar Green >25lb InHouse Use	1.00	\$9.50	-\$0.95	\$0.00	\$8.55
	Boarding Animal Control	1.00	\$30.00	-\$2.25	\$2.25	\$30.00

Subtotal: \$38.55

Discounts	Shelters/PetStore	-\$3.20
-----------	-------------------	---------

Invoice Summary

Patient Name	Total Price	Total Discount	Total Tax	Total Due
2020-1-1-Chocolate Lab	\$39.50	-\$3.20	\$2.25	\$38.55

	Total Due:	\$38.55
	Amount Paid:	\$0.00

For information on how we collect and use information about you and your pet, and how you may opt-out of some uses, please see our Privacy Policy at vcahospitals.com/privacy-policy.

Thank you for trusting us with your pet's care. Your friends at VCA Flannery Animal Hospital PC.

TOWN OF NEWBURGH

1496 ROUTE 300
NEWBURGH, N.Y. 12550

VOUCHER

DEPARTMENT

TONAC *AD 54239*

CLAIMANT'S
NAME
AND
ADDRESS

VCA Flannery Animal Hospital PC #4016
789 Little Britain Rd.
New Windsor NY 12553

TERMS

January 2020 Vouchers

Order No.

DO NOT WRITE IN THIS BOX

Date Voucher Received		VOUCHER NO.
FUND - APPROPRIATION	AMOUNT	
TOTAL		
Abstract No.		

Vendor's
Ref. No.

Dates	Quantity	Description of Materials or Services	Unit Price		Amount
1-1-20	Inv# 834872719-	2020-1-1 Check LAB (F)			38.55
1-4-20	Inv# 834872707	Emmy (F)			30.00
1-4-20	Inv# 834872708	Bandit			60.00 30.00
TOTAL					98.55
TOTAL					128.55

(See Instructions on Reverse Side)

CLAIMANT'S CERTIFICATION

I, *Jean Tobin*, certify that the above account in the amount of \$ *128.55* is true and correct; that the items, services and disbursements charged were rendered to or for the municipality on the dates stated; that no part has been paid or satisfied; that taxes, from which the municipality is exempt, are not included; and that the amount claimed is actually due.

1-7-20

DATE

Jean Tobin

SIGNATURE

Accts Manager

TITLE

(Space Below for Municipal Use)

DEPARTMENT APPROVAL

The above services or materials were rendered or furnished to the municipality on the dates stated and the charges are correct.

DATE

AUTHORIZED OFFICIAL

APPROVAL FOR PAYMENT

This claim is approved and ordered paid from the appropriations indicated above.

At a meeting of the Town Board of the Town of Newburgh, held at the Town Hall, 1496 Route 300, in the Town of Newburgh, Orange County, New York on the 16th day of October, 2013 at 7:00 P.M., Prevailing Time.

PRESENT:

- George Woolsey, Councilman
- Gilbert J. Piaquadio, Councilman
- Elizabeth J. Greene, Councilwoman
- Ernest C. Bello, Jr., Councilman

RESOLUTION TO ACKNOWLEDGE EXAMINATION OF THE RECORDS AND DOCKETS OF THE JUSTICE COURT OF THE TOWN OF NEWBURGH

Councilwoman Greene presented the following resolution which was seconded by Councilman Woolsey.

WHEREAS, Section 2019-a of the Uniform Justice Court Act requires that town justices annually provide their court records and dockets to their town auditing boards, and that such records then be examined or audited and that fact be entered into the minutes of the board's proceedings; and

WHEREAS, the Town Board of Town of Newburgh retained the firm of Vanacore DeBenedictus, DiGovanni & Wedel, LLP, Certified Public Accountants, to examine the records of the Town's Justice Court and a report of said examination dated July 1, 2013 has been submitted to the Town Board.

NOW, THEREFORE, BE IT RESOLVED that the Town of Newburgh Town Board, in its capacity as the auditing board of the Town of Newburgh, does hereby acknowledge that the required examination of the records and dockets of the Justice Court of the Town of Newburgh has been conducted and that the fines collected have been turned over to the proper officials of the Town; and

BE IT FURTHER RESOLVED, that the aforesaid resolution shall take effect immediately.

The question of the adoption of the foregoing resolution was duly put to a vote on roll call, which resulted as follows:

- George Woolsey, Councilman voting AYE
- Gilbert J. Piaquadio, Councilman voting AYE
- Elizabeth J. Greene, Councilwoman voting AYE
- Ernest C. Bello, Jr., Councilman voting AYE
- Wayne C. Booth, Supervisor voting ABSENT

The resolution was thereupon declared duly adopted

STATE OF NEW YORK)
COUNTY OF ORANGE) SS:
TOWN OF NEWBURGH)

I, Andrew J. Zarutskie, Town Clerk of the Town of Newburgh, DO HEREBY CERTIFY that I have compared the foregoing resolution, duly adopted by the Town Board of the Town of Newburgh on the 16th day of October, 2012, and entered in the minutes of the proceedings of said Board, and that the foregoing is a true and correct copy of said resolution and the whole thereof.

IN WITNESS WHEREOF, I have hereunto set my name and the seal of said Town on this 17th day of October, 2012.

Andrew J. Zarutskie, Town Clerk

State of New York
Unified Court System

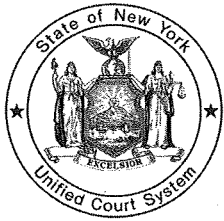

DEC 30 2019

25 Beaver Street
New York, N.Y. 10004
(212) 428-2100

Lawrence K. Marks
Chief Administrative Judge

December 27, 2019

Supervisor Gilbert Piaquadio
Town of Newburgh
1496 Route 300
Newburgh, NY 12550

Dear Supervisor Piaquadio:

Section 2019-a of the Uniform Justice Court Act requires that town and village justices annually provide their court records and dockets to their respective town and village auditing boards, and that such records then be examined, and that fact be entered into the minutes of the board's proceedings.

The Unified Court System's Internal Audit office is responsible for monitoring town and village board compliance with Section 2019-a. Accordingly, I am requesting that you provide a copy of the audit of your local court's records for fiscal year ending in 2019 and a copy of your board resolution acknowledging that the required examination was conducted. Please email the report and the resolution to jcasazza@nycourts.gov or mail to George Danyluk, Chief Internal Auditor, NYS Unified Court System, 2500 Pond View, Suite LL01, Castleton-on-Hudson, NY 12033. Please respond by March 1, 2020.

If you have any questions, please contact Joan Casazza at (518) 238-4303 or at the email listed above. Thank you for your cooperation.

Very truly yours,

A handwritten signature in black ink, which appears to read "George Danyluk". The signature is written in a cursive style.

/smw

c: George Danyluk, CIA
Joan Casazza, CIA

TOWN OF NEWBURGH – JUSTICE COURT
AGREED UPON PROCEDURES
FOR THE YEAR ENDED DECEMBER 31, 2018

APPROVED
DATE OF TOWN ACTION: 10/28/19

VOTE OF TOWN BOARD 5-0

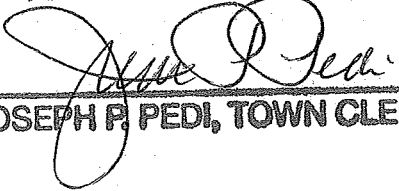
JOSEPH F. PEDI, TOWN CLERK

- Town Supervisor
- Justice Court

**TOWN OF NEWBURGH - JUSTICE COURT
AGREED-UPON PROCEDURES
FOR THE YEAR ENDED DECEMBER 31, 2018**

TABLE OF CONTENTS

DESCRIPTION	<u>PAGE(S)</u>
I. Independent Accountant's Report on Applying Agreed-Upon Procedures.....	1 - 2
II. Exhibit I – Town Justice Martini	3
III. Exhibit II – Town Justice Clarino	4



LIMITED LIABILITY PARTNERSHIP
CERTIFIED PUBLIC ACCOUNTANTS BUSINESS DEVELOPMENT CONSULTANTS

INDEPENDENT ACCOUNTANT'S REPORT
ON APPLYING AGREED-UPON PROCEDURES

Town Council
Town of Newburgh
311 Route 32
Newburgh, New York 12550

We have performed the procedures enumerated below, which were agreed to by the Town, related to the Town of Newburgh Justice Court's compliance with the annual accounting and audit procedures required in the Uniform Justice Court Act Section 2019-a and described in the Local Government Management Guide (LGMG), Chapter 13, published by the NYS Comptroller's Office (NYS OSC), during the period January 1, 2018 to December 31, 2018. The Town of Newburgh Justice Court is responsible for its compliance with those requirements. The sufficiency of these procedures is solely the responsibility of those parties specified in this report. Consequently, we make no representations regarding the sufficiency of the procedures enumerated below either for the purpose for which this report has been requested or for any other purpose.

We performed the following procedures, on a sample basis, which correspond to compliance with the NYS OSC's requirements, and are described in further detail in Exhibits 1 & 2:

- Test that Cash Receipts procedures comply with NYS OSC LGMG requirements;
- Test that Cash Disbursement procedures comply with NYS OSC LGMG requirements;
- Test that cash reconciliations are prepared accurately and timely;
- Test that record keeping procedures comply with NYS OSC LGMG requirements;
- Test that required reporting is sufficient and filed both timely and accurately.

This agreed-upon procedures engagement was conducted in accordance with attestation standards established by the American Institute of Certified Public Accountants. We were not engaged to and did not conduct an examination or review, the objective of which would be the expression of an opinion or conclusion, respectively, on compliance with specified requirements. Accordingly, we do not express such an opinion or conclusion. Had we performed additional procedures, other matters might have come to our attention that would have been reported to you.

Procedures performed

Sampled 11 cash receipt transactions in order to verify that cash receipts were issued and were pre-numbered; duplicate copies of receipts and deposit slips were kept for court records; deposits were made within 72 hours of collection; undeposited receipts were safeguarded; and receipts were recorded in the cashbook. Verified that the receipts were included in the total, which was filed monthly with NYS.

Procedures performed comply with NYS OSC LGMG requirements.

All cash receipts selected were pre-numbered. Duplicate copies of deposit slips were kept for court records. Receipts were both manually entered in the Cash Ledger One-Write System, and electronically entered in the Cash Book in the SEI software. All selected deposits were made within 72 hours of collection, or were online transactions. Undeposited receipts were safeguarded. Receipts were recorded in the cashbook, and totals for months selected agreed to the report filed with the State.

None noted.

Sampled 11 checks in order to verify that checks were pre-numbered and signed by the Justice. Vouched to bank statements to verify they included a copy of each cancelled check selected.

That Cash Disbursement procedures comply with NYS OSC LGMG requirements.

All checks selected were pre-numbered and signed by the Justice. Bank statements included a copy of the cancelled checks for both bank accounts.

None noted.

Examined 2 months of bank reconciliations to determine that they were prepared accurately and timely.

That cash reconciliations are prepared accurately and timely.

Bank reconciliations for the 2 months selected were prepared within 2 weeks of month end for both the fine and bail accounts, and were signed and dated by both the clerk and the Judge.

None noted.

Evaluated procedures and records for 11 case files to verify that case files were indexed using case numbers and dockets for disposed cases agreed with amounts reported to the State. Ensured that a list of Bail was maintained, and that installment payments are either not permitted or are tracked. Verified that backups of court records were maintained.

That record keeping procedures comply with NYS OSC LGMG requirements.

All selected case files were indexed using case numbers. Dockets for disposed cases and installment payments agreed with amounts reported to the State. A list of Bail is maintained. Monthly reports are backed up to an external flash drive. Court records are backed up weekly to the SEI cloud.

None noted.

Reviewed 6 months of reporting for the following: Reports are filed timely to the Justice Court Fund, the Department of Motor Vehicles and the Division of Criminal Services (if applicable) and pending cases are corrected with the assistance of a representative at DMV, where applicable.

That required reporting is sufficient and filed both timely and accurately.

All selected reports were filed timely to the Justice Court Fund. Pending cases were confirmed as still open and awaiting action by either the defendant or the Court. The errors on the TSLED Error report and the CDR-540 Error Report, which displays records that failed the NYS mainframe validation process, had been corrected as of field work testing date.

None noted.

Procedure	Proficiencies	Deficiencies	Recommendations
<p>Test that Cash Receipts procedures comply with NYS OSC LGMG requirements.</p>	<p>All cash receipts selected were pre-numbered. Duplicate copies of receipts and deposit slips were kept for court records. All selected deposits were made within 72 hours of collection. Undeposited receipts were safeguarded. Receipts were recorded in the cashbook, and totals for months selected agreed to the report filed with the State.</p>	<p>The date and type of payment and the receipt number were not included in the case file for one selection. The receipt number was not included in the case file for one selection.</p>	<p>RBT recommends that all case files/tickets include receipt number and the date, type and amount of payment received.</p>
<p>Test that Cash Disbursement procedures comply with NYS OSC LGMG requirements.</p>	<p>All checks selected were pre-numbered and signed by the Judge. Although bank statements for the fine and bail accounts opened in October 2018 do not include copies of the cancelled checks, copies were provided for selections and agreed to supporting documentation.</p>	<p>None noted.</p>	<p>The monthly bank statements will include copies of cancelled checks for the new bail and fine accounts beginning with the June 2019 bank statements.</p>
<p>Test that cash reconciliations are prepared accurately and timely.</p>	<p>Sampled 12 checks in order to verify that checks were pre-numbered and signed by the Judge. Vouched to bank statements to verify they included a copy of each cancelled check selected.</p>	<p>None noted.</p>	<p>RBT recommends that the Justice Clerk complete the monthly bank reconciliation, to agree the bail bank account to the Bail Activity Report and to agree the fine bank account to the amount remitted to the Supervisor in the subsequent month, taking into account current deposits in transit and outstanding checks. In addition, all variances should be investigated and corrected within two weeks of identification. Sample reconciliation files have been provided to the Justice Clerk.</p>
<p>Test that record keeping procedures comply with NYS OSC LGMG requirements.</p>	<p>Examined 2 months of bank reconciliations to determine whether they were prepared accurately and timely.</p>	<p>None noted.</p>	<p>RBT recommends tracking the outstanding installment payments on cases, and printing the "Current Bail Defendants Report" at the end of each month and reconciling that report to the bank account.</p>
<p>Test that required reporting is sufficient and filed both timely and accurately.</p>	<p>Evaluated procedures and records for 12 case files to verify that case files were indexed using case numbers and dockets for disposed cases agreed with amounts reported to the State. Ensured that a list of Bail was maintained and that installment payments are either not permitted or are tracked. Verified that backups of court records were maintained.</p>	<p>Outstanding installment payments are not being tracked. The list of bail printed from the SEI software did not reconcile to the bank balance.</p>	<p>None.</p>
<p>Test that required reporting is sufficient and filed both timely and accurately.</p>	<p>Reviewed 6 months of reporting for the following: Reports were filed timely to the Justice Court Fund, the Department of Motor Vehicles and the Division of Criminal Services (if applicable) and pending cases were corrected with the assistance of a representative at DMV, where applicable.</p>	<p>All selected reports were filed timely to the Justice Court Fund. Pending cases were confirmed as still open and awaiting action by either the defendant or the Court. The errors on the TSLED Error report and the CDR-540 Error Report, which displays records that failed the NYS mainframe validation process, had been corrected as of field work testing date.</p>	<p>None noted.</p>



NEWBURGH TOWN COURT
311 ROUTE 32
NEWBURGH, NEW YORK 12550

TELEPHONE (845) 564-7161
FACSIMILE (845) 564-7171

HON. RICHARD CLARINO
TOWN JUSTICE

ABIGAIL PUNTAR
COURT CLERK TO TOWN JUSTICE

December 13, 2019

Supervisor Gil Piaquadio
Town of Newburgh Town Hall
1496 Route 300
Newburgh, NY 12550

Dear Supervisor Piaquadio:

Pursuant to Uniform Justice Court Act § 2019-a, it is the duty of every Justice to present his/her records and docket, at least once a year and upon the last audit day of the town, to the auditing board of the town, which shall examine said records or docket, or cause same to be examined, and enter in the minutes of its proceedings the fact that they have been duly examined.

Consistent with Section 2019-a of the Uniform Justice Court Act, I hereby advise that the records and docket for the Town of Newburgh Court for Calendar Year 2019 are available to be presented for such examination. I look forward to working with you to schedule such examination in an expeditious manner.

It is my understanding that OCA's Internal Audit Services (IAS) unit will be corresponding with you as well in the very near future in this regard. Subsequent to the audit or examination, please forward to the IAS unit the audit report, as well as the Board's resolution noting that the records have been duly examined, and that the fines therein collected have been turned over to the proper officials of the Town as required by law. Such materials may be mailed to the following:

Internal Audit Services Unit
Attn: Joan Casazza
2500 Pond View, Suite LL01
Castleton-on-Hudson, NY 12033

In the alternative, such materials may be sent via email to: jcasazza@nycourts.gov. Thank you.

Very truly yours,

RICHARD CLARINO
Town Justice

cc: Arielle Bryant, Esq.
Elizabeth J. Greene, Councilwoman
Scott Manley, Councilman
James Presutti, Councilman
Paul Ruggiero, Councilman



NEWBURGH TOWN COURT
311 ROUTE 32
NEWBURGH, NEW YORK 12550

TELEPHONE (845) 564-7165
FACSIMILE (845) 564-7171

HON. JUDE T. MARTINI
TOWN JUSTICE

SAZIYE MUSTAFA
COURT CLERK TO TOWN JUSTICE

December 13, 2019

Supervisor Gil Piaquadio
Town of Newburgh Town Hall
1496 Route 300
Newburgh, NY 12550

Dear Supervisor Piaquadio:

Pursuant to Uniform Justice Court Act § 2019-a, it is the duty of every justice to present his/her records and docket, at least once a year, to the auditing board of the village or town, which shall examine said records or docket, or cause same to be examined, and enter in the minutes of its proceedings the fact that they have been duly examined.

Consistent with Section 2019-a of the Uniform Justice Court Act, I hereby advise that the court's records and docket are available to be presented for such examination. I look forward to working with you to schedule such examination in an expeditious manner.

It is my understanding that OCA's Internal Audit Services (IAS) unit will be corresponding with you as well in the very near future in this regard. Subsequent to the audit or examination, please forward to the IAS unit the audit report, as well as the Board's resolution noting that the records have been duly examined, and that the fines therein collected have been turned over to the proper officials of the Town as required by law. Such materials may be mailed to the following:

Internal Audit Services Unit
Attn: Joan Casazza
2500 Pond View, Suite LL01
Castleton-on-Hudson, NY 12033

In the alternative, such materials may be sent via email to: jcasazza@nycourts.gov

Thank you.

Very truly yours,

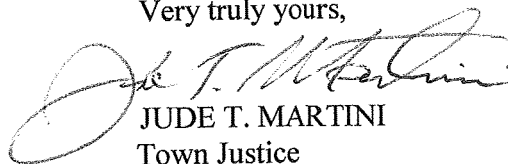
JUDE T. MARTINI
Town Justice

cc: Arielle Bryant, Esq.
Elizabeth J. Greene, Councilwoman (w/out attachments)
Scott Manley, Councilman (w/out attachments)
James Presutti, Councilman (w/out attachments)
Paul Ruggiero, Councilman (w/out attachments)



TOWN OF NEWBURGH

1496 Route 300, Newburgh, New York 12550

PERSONNEL DEPT.

PH: 845-566-7785
Fax: 845-564-2170

To: Gilbert Piaquadio, Supervisor ✓
Town Board Members

From: Charlene M. Black, Personnel Director 

Date: December 30, 2019

Re: Part Time Custodial Worker

Mr. Piaquadio has requested approval to hire Thomas Abbruscato as a part time custodial worker. The applicant's hiring is contingent on your approval and the completion of his fingerprints, paperwork, drug/alcohol screening and physical. A start date of on or after February 3, 2020 is anticipated. Thank you in advance.

TOWN OF NEWBURGH

EMPLOYMENT REQUEST FORM

To: Personnel Department

NAME OF CANDIDATE: Thomas Abbuscato

DEPARTMENT: Building + Grounds

TITLE OF POSITION: Custodial Worker

FULL TIME OR PART TIME: Part time

HOURLY RATE: \$12.50

IS POSITION FUNDED IN CURRENT BUDGET: YES OR NO

FUND APPROPRIATION NUMBER: 1626.0100

PROPOSED HIRE DATE: 2/3/2020

NOTE: CANDIDATE CANNOT BEGIN WORK WITHOUT FINGERPRINTS, PRE-EMPLOYMENT PHYSICAL, DRUG/ALCOHOL TESTING AND COMPLETION OF ALL REQUIRED PAPERWORK.



DEPARTMENT HEAD SIGNATURE

DATE

ORIGINAL APPLICATION SHOULD BE ON FILE IN THE PERSONNEL DEPARTMENT



TOWN OF NEWBURGH

1496 Route 300, Newburgh, New York 12550

GIL PIAQUADIO
Supervisor

845-564-4552
Fax: 845-566-9486
e-mail: supervisor@townofnewburgh.org

January 27th Workshop Meeting Garbage and Recyclable Collection

On January 16, 2020 the town received quotes for garbage collection from County Waste and Marangi.

County Waste Bid on a three year contract an average of \$ 17,238.36

I am recommending the town select Marangi with a three year contract averaging \$ 15,064.32.48.

With excess pricing per cubic yard for 2020 is \$ 5.00.

Garbage and Recyclable Collection

Bid Opening: Thursday, January 16, 2020 at 2:00 pm

County Waste	Marangi
--------------	---------

Option A
One Year Contract

Standard Pricing for Year 2020	\$17,238.36	\$14,334.48
Excess Pricing per cubic yard for 2020	\$6.88	\$5.00

Option B
Two Year Contract

Standard Pricing Per Year for Year 2020	\$17,238.36	\$14,334.48
Standard Pricing Per Year for Year 2021	\$17,238.36	\$15,051.24
Average Pricing for Year 2020 and 2021	\$17,238.36	\$14,692.86
Average Per Cubic Year Pricing for Year 2020 and 2021	\$6.88	\$5.00

Option C
Three Year Contract

Standard Pricing for Year 2020	\$17,238.36	\$14,334.48
Standard Pricing for Year 2021	\$17,238.36	\$15,051.24
Standard Pricing for Year 2022	\$17,238.36	\$15,803.76
Average Pricing for Year 2020, 2021 and 2022	\$17,238.36	\$15,064.32
Average Per Cubic Year Pricing for Year 2020 2021 and 2022	\$6.88	\$5.00

Town of Newburgh

Section 34 Block 2 Lot 38.32

TOWN OF NEWBURGH

Stormwater Control Facility Maintenance Agreement

THIS AGREEMENT is made this 5th day of Dec., 2019 by and between the Town of Newburgh, having an address at 1496 Route 300, Newburgh, New York 12550 ("Municipality") and Unifirst Corporation, having an address at 68 Jonspin Road, Wilmington, MA 01887 (the "Facility Owner").

Whereas, the Municipality and the Facility Owner want to enter into an agreement to provide for the long term maintenance and continuation of stormwater control measures approved by the Municipality for the below named project; and

Whereas, the Facility Owner is the owner of certain real property in the Town of Newburgh consisting of approximately +/- 1.78 acres more particularly described in Schedule "A" annexed hereto and made a part hereof (the "Property"); and

Whereas, the Municipality and the Facility Owner desire that the stormwater control measures be built in accordance with the approved project plans and thereafter be maintained, cleaned, repaired, replaced and continued in perpetuity in order to ensure optimum performance of the components.

Now, therefore, the Municipality and the Facility Owner agree as follows:

1. This agreement binds the Municipality and the Facility Owner, its successors and assigns to the maintenance provisions depicted in the approved project plans and Stormwater Pollution Prevention Plan which are on file with the Municipality's Stormwater Management Officer.
2. The Facility Owner shall maintain, clean, repair, replace and continue the stormwater control measures depicted on the approved project plans for the Facility known as 33 Jeanne Drive on and about the Property, as necessary to ensure optimum performance of the measures to design specifications. The stormwater control measures shall include, but shall not be limited to, the following: drainage ditches, swales, dry wells, infiltrators, drop inlets, pipes, culverts, soil absorption devices and retention ponds and other stormwater practices identified in the Stormwater Pollution Prevention Plan (SWPPP) approved by the Municipality.
3. The Facility Owner shall be responsible for all expenses related to the maintenance of the stormwater control measures and shall establish a means for the collection and distribution of expenses among parties for any commonly owned facilities.

4. The Facility Owner shall provide for the periodic inspection of the stormwater control measures, not less than once a year, to determine the condition and integrity of the measures. Such inspection shall be performed by a Professional Engineer licensed by the State of New York. The inspecting engineer shall prepare and submit to the Municipality within 30 days of the inspection, a written report of the findings including recommendations for those actions necessary for the continuation of the stormwater control measures.
5. The Facility Owner shall not authorize, undertake or permit alteration, abandonment, modification or discontinuation of the stormwater control measures except in accordance with written approval of the Municipality. The obligations of the Facility Owner under paragraphs 2, 3, 4 and 6 of this Agreement shall toll upon the completion of the establishment of a drainage district of the Municipality and the acceptance of the dedication of the stormwater control measures by the Municipality. The tolling period shall end upon the discontinuance or dissolution of the municipal drainage district.
6. The Facility Owner shall undertake necessary maintenance, repairs and replacement of the stormwater control measures at the direction of the Municipality or in accordance with the recommendations of the inspecting engineer.
7. The Facility Owner shall provide to the Municipality within 30 days of the date of this agreement, such security for the maintenance and continuation of the stormwater control measures as the Municipality may have required in its approval in the form acceptable to the Town Engineer and Town Attorney (a bond, letter of credit or escrow account).
8. This agreement shall be recorded in the Office of the County Clerk, County of Orange and shall be included in any offering plan and/or prospectus or lease. All rights, title and privileges herein granted, including all benefits and burdens, shall run with the land and shall be binding upon and inure to the benefit of the parties hereto, their respective heirs, executors, administrators, successors, assigns and legal representatives.
9. If ever the Municipality determines that the Facility Owner has failed to construct or maintain the stormwater control measures in accordance with the project plans or has failed to undertake corrective action specified by the Municipality or by the inspecting engineer, the Municipality is authorized to undertake such steps as reasonably necessary for the preservation, continuation or maintenance of the stormwater control measures and to affix the expenses thereof as a lien against the property. The Facility Owner shall reimburse the Municipality for all costs and expenses, including reasonable attorneys' fees, incurred in enforcing this Agreement and curing a violation.
10. This agreement is effective _____, 2019.

IN WITNESS WHEREOF, the parties have duly executed this agreement as of the day and year first above written.

TOWN OF NEWBURGH

UNIFIRST CORPORATION

By: _____
Gilbert J. Piaquadio, Supervisor

By: SA SA
Printed Name: Steven Sintros
Title: President & CEO

RETURN TO:

Mark C. Taylor, Esq.
Rider, Weiner & Frankel, P.C.
PO Box 2280
Newburgh, New York 12550

STATE OF NEW YORK :)
 SS.
COUNTY OF ORANGE :)

On the _____ day of _____, in the year 2019 before me, the undersigned, personally appeared GILBERT J. PIAQUADIO personally known to me or proved to me on the basis of satisfactory evidence to be the individual whose name is subscribed to the within instrument and acknowledged to me that he executed the same in his capacity, and that by his signature on the instrument, the individual, or the person upon behalf of which the individual acted, executed the instrument.

Notary Public

STATE OF MASSACHUSETTS :)
 SS.
COUNTY OF Middlesex :)

On the 5th day of December, in the year 2019 before me, the undersigned, personally appeared STEVEN SINTROS personally known to me or proved to me on the basis of satisfactory evidence to be the individual whose name is subscribed to the within instrument and acknowledged to me that he executed the same in his capacity, and that by his signature on the instrument, the individual, or the person upon behalf of which the individual acted, executed the instrument.

Kelly J. Folta
Notary Public

 KELLY J. FOLTA
Notary Public
Commonwealth of Massachusetts
My Commission Expires
December 3, 2021

SCHEDULE "A"

ALL that certain plot, piece or parcel of land, situate, lying and being in the Town of Newburgh, County of Orange and State of New York, being known and designated as Parcel "A" and shown on a map entitled, "Lot Line Change Map, Lands of William R. Henry and R & V Realty, LLC" dated 18 July 2001 and last revised 27 August 2001 and filed in the Orange County Clerk's Office on 25 September 2001 as Map No. 205-01 and being bounded and described as follows:

BEGINNING at a point on the northerly line of Jeanne Drive and at the corner of Parcels A and B from aforesaid filed map; and

RUNNING THENCE along said line of Jeanne Drive, North 70 degrees 31 minutes 30 seconds West 201.11 feet to a point;

THENCE leaving said line and along the line of lands now or formerly of Joseph Falanga, Jr., North 19 degrees 28 minutes 30 seconds East 386.54 feet to a point in a stonewall;

THENCE along said stonewall and the line of lands now or formerly of KB Yunc Associates, Inc. the following two courses and distances:

- 1) South 76 degrees 44 minutes 10 seconds East 19.82 feet to a point;
- 2) South 77 degrees 38 minutes 10 seconds East 168.73 feet to a point at the corner of aforementioned Parcels A and B;

THENCE along the division line of said parcel, South 17 degrees 31 minutes 15 seconds West 409.81 feet to the point or place of BEGINNING.



TOWN OF NEWBURGH

19

1496 Route 300, Newburgh, New York 12550

RONALD E. CLUM, CPA
ACCOUNTANT

845-564-5220

Fax: 845-566-9461

E-Mail: rclumaccountant@townofnewburgh.org

To: Gil Piaquadio, Town Supervisor
CC: Town Board
From: Ronald E. Clum, Town Accountant
Date: January 22, 2020
RE: Budget Transfers

Please find below a listing of budget adjustments that need to be made upon review of the year to date budget status report. As this requires board action, I am requesting this to be put onto the next agenda and approved accordingly.

Thank you in advance for your approval.

FROM ACCOUNT		TO ACCOUNT	Dollar Amount
Account Description/ Account Name	Account Number/ Account Name		
A.1990.5499 CONTINGENCY ACCOUNT	A.3120.5462 POLICE UNIFORMS		\$ 11,100.00
F.9010.5800 WATER-STATE RETIREMENT	F8310.5490 WATER-INTERGOV'T GENERAL SERV		\$ 16,500.00