



CRH REALTY VIII, LLC / BRITAIN PLAZA TOWN OF NEWBURGH, NEW YORK

STORMWATER POLLUTION PREVENTION PLAN

PREPARED BY
LANC & TULLY P.C.

DECEMBER 10, 2013
REVISED DECEMBER 13, 2013
REVISED FEBRUARY 25, 2014

I. INTRODUCTION

This Stormwater Pollution Prevention Plan (SWPPP) has been prepared to cover two separate projects in the Town of Newburgh, the Crystal Run Healthcare medical office building and Britain Plaza commercial building, with a combined stormwater collection and treatment system. Six parcels in the Town of Newburgh and one in the Town of New Windsor will be realigned and consolidated to three parcels, including one in the Town of New Windsor. One of the Town of the Newburgh parcels and the Town of New Windsor parcel totaling 7.30 acres will be developed by Crystal Run Healthcare and the remaining 1.27 acre parcel in the Town of Newburgh will be developed by Britain Plaza.

The Crystal Run Healthcare project consists of the construction of a 65,390 square foot medical office building, parking areas, access roads, and associated utilities. The Britain Plaza project consists of the construction of a 9,000 square foot commercial building, parking area, and associated utilities. The projects will be serviced with municipal water and sewer. Stormwater for both projects will be collected and treated on-site and treated through several NYSDEC approved stormwater management practices. Portions of the stormwater systems will be shared, including the stormwater pond, piping, and stormwater pond discharge point. The projects are located on the western side of Lake Washington, the primary drinking water supply for the City of Newburgh. Since the site is within the watershed of the lake, the proposed stormwater system must be designed to treat 110% of the required water quality volume. The two projects together are anticipated to disturb a total of approximately 8.68 acres, though separate Notices of Intent will be submitted to the New York State Department of Environmental Conservation (NYSDEC) for each project. The Crystal Run Healthcare project will disturb approximately 7.38 acres, based on the size of the proposed building and the grading required the applicant will seek a waiver from the Town of Newburgh to allow greater than 5 acres to be disturbed at a time. The Britain Plaza project will disturb approximately 1.36 acres, requiring only a single phase.

The impacts of this type of development must be evaluated, and if necessary, mitigated to ensure minimal impact on the stormwater drainage patterns within the site watershed areas. The purpose of this study is to evaluate if any impacts are associated with the proposed development, ensure treatment of the water quality volume as per current NYSDEC stormwater standards, and make certain that no increases in the peak discharge from the proposed construction are created as part of State Pollutant Discharge Elimination System (SPDES) General Stormwater Permit GP-0-10-001.

II. APPENDICES TO THIS PLAN

The following is a list of the Appendices included with this report.

- A. Location Map for Project
Soils Report for Project
- B. Pre- and Post-Development Watershed Models
- C. Pre- and Post-Development Watershed Maps
- D. Calculations:
Water Quality/Runoff Reduction Volume

- Stormwater Practice Design
- E. Excerpts from the "New York State Stormwater Design Manual"
Construction Specifications
- F. Standard Construction and Maintenance Inspections Forms
- G. Notice of Intent
Notice of Termination
- H. Construction Site Log Book
Contractor's Certification Statement
- I. Pipe Sizing Analysis
- J. Test Pit Information
- K. Site Plans

III. CURRENT REGULATIONS

Stormwater runoff and its subsequent impact to receiving water bodies led Federal, State and Local officials to set new standards on stormwater discharge to attempt to restore stream water quality and control peak flow rates for specific storm events. According to 40 CFR, Part 122 prohibits point source discharges of stormwater to waters of the United States without a permit issued under the National Pollutant Discharge Elimination System (NPDES). The EPA to administer the NPDES program approves the NYSDEC; therefore SPDES regulations are currently in effect. Current regulations require that any construction site proposing a disturbance of one acre or greater prepare a Stormwater Pollution Prevention Plan. This SWPPP consists of the following: water quality treatment and control, water quantity control and an Erosion and Sediment Control Plan. Preparation of each portion of the SWPPP depends on the type and level of construction proposed. The proposed development requires the preparation of a full Stormwater Pollution Prevention Plan that includes all of the items mentioned above. Also as part of the SWPPP, the filing of a Notice of Intent five days prior to construction to the NYSDEC Bureau of Water Permits located at 625 Broadway, Albany, New York (see Appendix G) is required. This NOI identifies all of the major requirements and design criteria that are necessary for the site drainage design. This form shall be signed and certified by the owner/operator of the site. A contractor's certification statement (see Appendix H) shall also be completed by the general contractor and subcontractors and submitted to the Town of Newburgh Building Department to ensure on site compliance with local regulations.

IV. METHODOLOGY

The analysis presented in this report was developed using the Bentley Systems computer software program called PondPack. PondPack is based upon and implements the Soil Conservation Service Technical Release 55 (SCS TR-55) "Urban Hydrology for Small Watersheds Methodology" for computing CN, Tc, Runoff values, and hydrographs for the development of drainage and hydraulic calculations. For purposes of this report and in accordance with the regulations set forth by the NYSDEC as part of a SPDES Permit for Stormwater Discharges from Construction Activities, the 1-(Channel Protection), 10-(Over bank Flood), and 100-year (Extreme Storm) storm events were analyzed. This analysis is specific for this site and is based on current and proposed land cover, underlying soil types, weighted runoff coefficients, theoretical flow paths,

and rain events. These were then input into the computer model, which developed hydrographs for both pre- and post-development conditions. This information is shown in Appendices B and C.

V. WATER QUANTITY

The NYSDEC has selected three criteria as part of the stormwater quantity regulations. They are summarized as follows:

Channel Protection:	24-hour extended detention of post-developed one-year, 24-hour storm event
Over bank Flood:	Control the peak discharge from the 10-year storm to 10-year pre-development rates
Extreme Storm:	Control the peak discharge from 100-year storm to 100-year pre-development rates

The site has been designed to limit post-development flow rates to less than or equal to pre-development flow rates at all study points. The site watershed has been divided into three main areas labeled as A, B, and C in the pre-development model. Study point A is the flow exiting the site along the southeastern property line, flowing to Lake Washington. Study point B is the flow exiting the site along the northeastern property line, flowing to the rear of the residential lots along Old Little Britain Road. Study point C is the flow exiting the site at the corner of NYS Route 300 and Old Little Britain Road, flowing along Old Little Britain Road. In post-development conditions watershed A was split into 9 sub areas, watershed B was split into 2 sub areas, and watershed C was split into 2 sub areas. All watershed areas within the site have detailed summations of the characteristics for both pre- and post-development as listed in Section VI & VII of this report.

Channel protection volume control has been provided in the proposed stormwater pond through a low flow orifice. See Appendix D for channel protection volume and orifice sizing calculations.

VI. PRE-DEVELOPMENT CONDITIONS

With the information available on the U.S.G.S. Mapping, Orange County Water Authority mapping, and the site survey, the drainage occurring on the project site has been divided into three watershed areas. Figures are provided within Appendix C which depict the watershed areas that were utilized in the hydraulic computer model. No wetlands exist within the site. The soil boundaries and types shown are based upon the Orange County Soil Survey as documented by the Soil Conservation Service, a detailed soil classification report including maps is included in Appendix A. The soils at the site are predominantly Mardin gravelly silt loam, a hydrologic soil group D soil.

Area A consists of approximately 6.90 acres of land encompassing the central and southern portions of the site. The area includes an abandoned animal hospital, abandoned dwelling and pool, abandoned automobile service station, and parking areas. The abandoned buildings are surrounded by grass, woods, and

brush. There is 1.27 acres impervious cover in this area consisting of the abandoned buildings, parking areas, and small portion of NYS Route 300. The buildings and pavement associated with the abandoned buildings will be removed as part of this project. Stormwater runoff in this area flows to the southeastern property line, study point B. The pre-development peak discharge for this watershed is summarized in Table 1, located below, as well as in the pre-development model located in Appendix B.

Area B consists of approximately 0.82 acres of land encompassing the northeast corner of the site, behind the commercial/residential lots. The area includes mostly grass and trees, no impervious cover exists in this area. Stormwater runoff in this area flows north to the property line, study point A. The pre-development peak discharge for this watershed is summarized in Table 1, located below, as well as in the pre-development model located in Appendix B.

Area C consists of approximately 1.66 acres of land in the northern corner of the property at the intersection of NYS Route 300 and Old Little Britain Road. The area includes two commercial/residential lots and grassed area. There is 0.32 acres impervious cover in this area consisting of commercial/residential buildings and small portion of NYS Route 300. The buildings and pavement associated with the commercial/residential lots will be removed as part of this project. Stormwater runoff in this area flows north to the intersection of NYS Route 300 and Old Little Britain Road, study point C. The pre-development peak discharge for this watershed is summarized in Table 1, located below, as well as in the pre-development model located in Appendix B.

Watershed Area	Area (Ac.)	CN	Tc (hrs.)	1 Year Peak Runoff (cfs)	10 Year Peak Runoff (cfs)	100 Year Peak Runoff (cfs)
Area A	6.90	85	.469	6.94	17.48	27.85
Area B	0.82	83	.265	0.93	2.47	3.99
Area C	1.66	86	.360	1.96	4.81	7.58
Study Point A	6.90	--	--	6.94	17.48	27.85
Study Point B	0.82	--	--	0.93	2.47	3.99
Study Point C	1.66	--	--	1.96	4.81	7.58

Table 1: Pre-Development Conditions

VII. POST-DEVELOPMENT CONDITIONS

The proposed development includes two projects: Crystal Run Healthcare project including the construction of a 65,390 square foot medical office building, parking areas, and associated utilities and the Britain Plaza project including the construction of a 9,000 commercial building, parking area, and associated utilities. Fifteen stormwater areas are proposed throughout the project site for water quality treatment and stormwater quantity control. Stormwater treatment will be provided through a combination of filtration, infiltration, and stormwater pond permanent pool. Several of the proposed practices provide runoff reduction volume credits (RRV), including the porous pavement, bio-retention areas, and rain gardens. In order to minimize site disturbance and mimic existing drainage patterns, existing topography was held to the greatest extent possible when determining the proposed site grading. The study points utilized for the pre-development

conditions were maintained and evaluated for post-development conditions. Below is a description of each watershed subarea that correlates with the post-development drainage area map provided in Appendix C.

Area A1 consists of approximately 0.73 acres of land at the southern corner of the site. This area includes perimeter grading for the main site entrance. No impervious cover is proposed in this area. Stormwater runoff in this area follows pre-development conditions. No stormwater practices are proposed for this area. The post-development peak discharge for this area is summarized in Table 2, located below, as well as in the post-development model located in Appendix B.

Area A2 consists of approximately 3.02 acres of land encompassing the area of the site draining to the proposed stormwater pond, but not the areas draining to the bio-retention areas. This area the proposed medical office building, parking, and access drives. Approximately 2.06 acres of impervious cover is proposed in this area, including 0.04 acres of porous pavement and the proposed building roof. Stormwater runoff from this area will be collected by a stormwater collection system and conveyed to the stormwater pond, a wet pond. A small portion of the roof runoff will be directed to 2 rain gardens for treatment. The stormwater pond will discharge to an existing easement on the property to the east of the site. The stormwater pond will provide water quality treatment through permanent pool and quantity control through stormwater detention. The porous pavement and rain gardens provide three main benefits: water quality treatment, runoff reduction volume credit (RRV) and reduction of runoff volume for smaller storms. The post-development peak discharge for this area is summarized in Table 2, located below, as well as in the post-development model located in Appendix B.

Area A3 is comprised of 0.52 acres to the east of the proposed medical office building. Approximately 0.47 acres of pavement is proposed, including 0.11 acres of porous pavement. Stormwater runoff from this area will be collected in porous pavement area. Smaller storms will infiltrate into the subgrade, while larger flows will drain either through the underdrain or the overflow catch basin at each end of aisle and will discharge to the proposed stormwater pond for quantity control. The porous pavement system provides three main benefits: water quality treatment, runoff reduction volume credit (RRV) and reduction of runoff volume for smaller storms. The post-development peak discharge for this area is summarized in Table 2, located below, as well as in the post-development model located in Appendix B.

Area A4 is comprised of 0.74 acres between the proposed medical office building and NYS Route 300. Approximately 0.41 acres of pavement is proposed, including 0.24 acres of porous pavement. Stormwater runoff from this area will be collected in porous pavement area. Smaller storms will infiltrate into the subgrade, while larger flows will drain either through the underdrain or the overflow catch basin at each end of aisle and will discharge to the proposed stormwater pond in Area A2 for quantity control. The porous pavement system provides three main benefits: water quality treatment, runoff reduction volume credit (RRV) and reduction of runoff volume for smaller storms. The post-development peak discharge for this area is summarized in Table 2, located below, as well as in the post-development model located in Appendix B.

Area A5 is comprised of 0.64 acres of land to the north of the proposed medical office building. This area includes bio-retention area 1 and surrounding parking area. Approximately 0.46 acres of impervious cover is proposed in this area, including the parking area. Stormwater runoff from this area will be collected by a central bio-retention area. Larger storms and overflow from the bio-retention area will be directed to the proposed stormwater pond in Area A2. Bio-retention area 1 provides water quality treatment and runoff

reduction volume credit for its drainage area. The post-development peak discharge for this area is summarized in Table 2, located below, as well as in the post-development model located in Appendix B.

Area A6 consists of approximately 0.28 acres of land to the west of the proposed medical office building. This area includes bio-retention area 2 and surrounding parking area. Approximately 0.23 acres of impervious cover is proposed in this area, including the parking area. Stormwater runoff from this area will be collected by a central bio-retention area. Larger storms and overflow from the bio-retention area will be directed to the proposed stormwater pond in Area A2. Bio-retention area 2 provides water quality treatment and runoff reduction volume credit for its drainage area. The post-development peak discharge for this area is summarized in Table 2, located below, as well as in the post-development model located in Appendix B.

Area A7 consists of approximately 0.15 acres of land to the west of the proposed medical office building. This area includes bio-retention area 3 and surrounding parking area. Approximately 0.07 acres of impervious cover is proposed in this area, including the parking area. Stormwater runoff from this area will be collected by a central bio-retention area. Larger storms and overflow from the bio-retention area will be directed to the proposed stormwater pond in Area A2. Bio-retention area 3 provides water quality treatment and runoff reduction volume credit for its drainage area. The post-development peak discharge for this area is summarized in Table 2, located below, as well as in the post-development model located in Appendix B.

Area A8 consists of approximately 0.40 acres of land to the west of the proposed medical office building. This area includes bio-retention area 4 and surrounding parking area. Approximately 0.32 acres of impervious cover is proposed in this area, including the parking area. Stormwater runoff from this area will be collected by a central bio-retention area. Larger storms and overflow from the bio-retention area will be directed to the proposed stormwater pond in Area A2. Bio-retention area 4 provides water quality treatment and runoff reduction volume credit for its drainage area. The post-development peak discharge for this area is summarized in Table 2, located below, as well as in the post-development model located in Appendix B.

Area A9 consists of approximately 0.62 acres of land to the west of the proposed medical office building. This area includes bio-retention area 5 and surrounding parking area. Approximately 0.54 acres of impervious cover is proposed in this area, including the parking area. Stormwater runoff from this area will be collected by a central bio-retention area. Larger storms and overflow from the bio-retention area will be directed to the proposed stormwater pond in Area A2. Bio-retention area 5 provides water quality treatment and runoff reduction volume credit for its drainage area. The post-development peak discharge for this area is summarized in Table 2, located below, as well as in the post-development model located in Appendix B.

Area B1 consists of approximately 0.20 acres of land encompassing the northeast corner of the site, behind the commercial/residential lots. This area includes perimeter grading for the proposed stormwater pond. No impervious cover is proposed in this area. Stormwater runoff in this area follows pre-development conditions. No stormwater practices are proposed for this area. The post-development peak discharge for this area is summarized in Table 2, located below, as well as in the post-development model located in Appendix B.

Area B2 consists of approximately 0.29 acres of land surrounding the proposed northern site entrance on Old Little Britain Road. Approximately 0.19 acres of impervious cover is proposed in this area, including the entrance road. Stormwater runoff from this area will be collected and directed to the proposed stormwater

pond in Area A2. The post-development peak discharge for this area is summarized in Table 2, located below, as well as in the post-development model located in Appendix B.

Area C1 consists of approximately 0.27 acres of land in the northern corner of the property at the intersection of NYS Route 300 and Old Little Britain Road. The area includes two commercial/residential lots and grassed area. This area includes perimeter grading for the Britain Plaza property. No impervious cover is proposed in this area. Stormwater runoff in this area follows pre-development conditions. No stormwater practices are proposed for this area. The post-development peak discharge for this area is summarized in Table 2, located below, as well as in the post-development model located in Appendix B.

Area C2 consists of approximately 1.20 acres of land surrounding the Britain Plaza project. This area includes bio-retention area 6 and surrounding parking area. Approximately 0.90 acres of impervious cover is proposed in this area, including the parking area. Stormwater runoff from this area will be collected by the bio-retention area. Larger storms and overflow from the bio-retention area will be directed to the proposed stormwater pond in Area A2. Bio-retention area 6 provides water quality treatment and runoff reduction volume credit for its drainage area. The post-development peak discharge for this area is summarized in Table 2, located below, as well as in the post-development model located in Appendix B.

Watershed Area	Area (Ac.)	CN	Tc (hrs.)	1 Year Peak Runoff (cfs)	10 Year Peak Runoff (cfs)	100 Year Peak Runoff (cfs)
A1	0.73	80	.091	0.88	2.48	4.09
A2	3.02	93	.142	6.10	12.71	18.96
A3	0.52	96	.094	1.20	2.36	3.47
A4	0.74	86	.095	1.20	2.90	4.54
A5	0.64	92	.189	1.19	2.53	3.79
A6	0.28	93	.161	0.56	1.15	1.72
A7	0.15	85	.118	0.22	0.56	0.89
A8	0.40	93	.117	0.84	1.75	2.60
A9	0.62	95	.083	1.41	2.80	4.13
B1	0.20	80	.180	0.22	0.62	1.03
B2	0.29	92	.105	0.60	1.26	1.89
C1	0.27	80	.346	0.24	0.68	1.13
C2	1.20	93	.110	2.53	5.24	7.81
Study Point A	8.59	--	--	1.30	16.64	27.84
Study Point B	0.20	--	--	0.22	0.62	1.03
Study Point C	0.27	--	--	0.24	0.68	1.13

Table 2: Post-Development Conditions

VIII. WATER QUALITY AND RUNOFF REDUCTION

The water quality volume denoted as WQ_v is designed to improve water quality sizing to capture and treat 90% of the average annual stormwater runoff volume. The WQ_v is directly related to the amount

impervious cover created at a site. New York State Department of Environmental Conservation has developed the following equation to determine the water quality storage volume. As of 2010, the NYSDEC requires that the water quality volume be treated through use of specific green infrastructure practices. The design of these practices is based on promoting infiltration of the water quality volume. The treatment provided by the green infrastructure practices is called the runoff reduction volume (RRv). The NYSDEC requires the RRv to equal the WQv unless site specific conditions do not allow the full treatment using green infrastructure practices. Table 3, shown below, describes the feasibility of the NYSDEC's Green Infrastructure Techniques.

Table 3: Green Infrastructure Technique Feasibility

Conservation of Natural Areas	
Retain the pre-development hydrologic and water quality characteristics of undisturbed natural areas, stream and wetland buffers by restoring and/or permanently conserving these areas on a site.	No natural areas exist within the project disturbance area delineated for the water quality calculation.
Sheetflow to Riparian Buffers or Filter Strips	
Undisturbed natural areas such as forested conservation areas and stream buffers or vegetated filter strips and riparian buffers can be used to treat and control stormwater runoff from some areas of a development project.	No riparian buffers exist on the site.
Vegetated Open Swale	
The natural drainage paths, or properly designed vegetated channels, can be used instead of constructing underground storm sewers or concrete open channels to increase time of concentration, reduce the peak discharge, and provide infiltration.	The bio-retention areas function similar to roadside swales in several areas.
Tree Planting / Tree Box	
Plant or conserve trees to reduce stormwater runoff, increase nutrient uptake, and provide bank stabilization. Trees can be used for applications such as landscaping, stormwater management practice areas, conservation areas and erosion and sediment control.	Trees are proposed throughout the parking area. See the description of this technique below.
Disconnection of Rooftop Runoff	
Direct runoff from residential rooftop areas and upland overland runoff flow to designated pervious areas to reduce runoff volumes and rates.	The large size of the proposed building roof will require use of a stormwater pond for treatment.
Stream Daylighting for Redevelopment Projects	
Stream Daylight previously-culverted/piped streams to restore natural habitats, better attenuate runoff by increasing the storage size, promoting infiltration, and help reduce pollutant loads.	The project is not a redevelopment, therefore this technique is not applicable.

Table 3: Green Infrastructure Technique Feasibility (continued)

Rain Garden	
Manage and treat small volumes of stormwater runoff using a conditioned planting soil bed and planting materials to filter runoff stored within a shallow depression.	Several bio-retention areas and rain gardens are proposed throughout the project area. See the description of this technique below.
Green Roof	
Capture runoff by a layer of vegetation and soil installed on top of a conventional flat or sloped roof. The rooftop vegetation allows evaporation and evapotranspiration processes to reduce volume and discharge rate of runoff entering conveyance system.	The structural design of the proposed buildings does not allow this technique.
Stormwater Planter	
Small landscaped stormwater treatment devices that can be designed as infiltration or filtering practices. Stormwater planters use soil infiltration and biogeochemical processes to decrease stormwater quantity and improve water quality.	The large size of the proposed building roof will require use of a stormwater pond for treatment.
Rain Tank / Cistern	
Capture and store stormwater runoff to be used for irrigation systems or filtered and reused for non-contact activities.	The large size of the proposed building roof will require use of a stormwater pond for treatment.
Porous Pavement	
Pervious types of pavements that provide an alternative to conventional paved surfaces, designed to infiltrate rainfall through the surface, thereby reducing stormwater runoff from a site and providing some pollutant uptake in the underlying soils.	The parking area will use sections of porous pavement to allow for stormwater infiltration. See the description of this technique below.

Below are calculations developed specifically for this site. Details for the water quality volume and runoff reduction volume calculations are provided in Appendix D of this report. The site is located within the watershed for Lake Washington, the primary drinking water source for the City of Newburgh, and must treat 110% of the required water quality volume. Below is summary of the required and provided water quality and runoff reduction volumes.

Required Water Quality Volume (WQ_v) = 24,141 cubic feet
 Required Water Quality Volume (WQ_v) + 10% = 26,555 cubic feet
 Required Minimum Runoff Reduction Volume (RR_v) = 4,676 cubic feet
Provided Runoff Reduction Volume (RR_v) = 12,460 cubic feet
 Required WQ_v minus the provided RR_v = 14,095 cubic feet
Provided Water Quality Volume (WQ_v) = 15,376 cubic feet
Total Treatment Volume Provided WQ_v + RR_v = 27,836 cubic feet

Several different practices are being proposed throughout the site for treatment of the water quality volume. See the map in Appendix C for locations of the stormwater practices. Descriptions for practices are shown below.

Tree Planting

Trees planted adjacent to impervious cover allow the drainage area to be reduced when calculating the water quality volume. The method of reduction chosen for this site is 100 square feet of drainage area for each tree. The site design calls for trees planted throughout the parking area. A total of 35 trees are proposed, allowing a 3,500 square foot reduction of the drainage area.

Rain Gardens

Rain gardens are small, vegetated stormwater treatment areas designed for capturing and infiltrating runoff from roofs, driveways, yards, and other small areas. Rain gardens are very similar to bio-retention areas, but are much smaller. Two rain gardens are proposed for this project and have been designed to treat runoff portions of the proposed medical building roof. The treatment volume of rain gardens is quantified as a volume, similar to a standard stormwater practice, such as a bio-retention area. The rain gardens will treat approximately 301 cubic feet of water quality volume.

Bio-Retention Areas

Bio-retention areas 1 through 6 are proposed for treating runoff from a portion of Areas A5, A6, A7, A8, A8, A9, B2, and C2. They have been designed to treat runoff from the proposed parking areas. Soil types on the site are hydrologic soil group D, meaning the up to 40% of the treatment volume of the bio-retention areas can be claimed as runoff reduction volume and remaining volume will be claimed as water quality volume. Combined, the five bio-retention areas allow the deduction of 3,944 cubic feet from the water quality volume and the 5,916 remaining cubic feet will treat standard water quality.

Porous Pavement

Six porous pavement parking areas are proposed. The porous pavement will be installed in a strip at the downslope end of several aisles, standard asphalt pavement will be used for the remainder of the parking area. Porous pavement consists of a high permeability asphalt pavement and layers of stone beneath the pavement designed to temporarily hold the water quality volume while it infiltrates. Catch basins will be installed at the low points with an outlet pipe raised above the subgrade to allow stormwater from storm events larger than the water quality storm to exit the stone reservoir, if necessary, through the underdrain. The total area of porous pavement is 16,950 square feet and will treat a total of 6,780 cubic feet of water quality volume.

Stormwater Pond

A stormwater pond is proposed for treating runoff and control flows from the majority of the site, Areas A2 through A, B2, and C2. The pond will be a wet pond, design P-2. Water quality treatment will be provided through permanent pool. The stormwater pond will provide 9,159 cubic feet of water quality treatment through permanent pool in the wet pool and forebays. A test pit was performed in the area of the

proposed stormwater pond which shows that neither bedrock nor groundwater exists within 2 feet of the invert of the stormwater pond. See Appendix J for test pit information.

IX. EROSION AND SEDIMENT CONTROL MEASURES

The general SPDES Permit (GP-0-10-001) for construction activities requires that an Erosion and Sediment Control Plan be developed. This plan has provided in as part of the Site Plans, and will be available at Town Hall and the project site at the time of construction. A separate Erosion and Sediment Control Plan will be prepared for each project. They will also be in compliance with current regulations, including construction sequence, both short- and long-term maintenance of facilities, storage of materials and temporary and permanent structures.

The following temporary and permanent erosion control practices are proposed for use during construction and for long-term protection:

A. **Stabilized Construction Entrance:**

A stabilized pad of aggregate underlain with geotextile located at any point where traffic will be entering or leaving a construction site to or from a public right-of-way, street, alley, sidewalk, or parking area. The purpose of stabilized construction entrance is to reduce or eliminate the tracking of sediment onto public rights-of-way or streets.

B. **Siltation Fence:**

A temporary barrier of geotextile fabric installed on the contours across a slope used to intercept sediment laden runoff from small drainage areas of disturbed soil. The purpose of a silt fence is to reduce runoff velocity and effect deposition of transported sediment loads. Limits imposed by ultraviolet stability of the fabric will dictate the maximum period the silt fence may be used (approximately one year). Silt fence will be placed as shown on the Sediment and Erosion Control Plans.

C. **Sediment Traps/Basins:**

A temporary sediment control device formed by excavation and/or embankment to intercept sediment laden runoff and retain the sediment. The purpose of the structure is to intercept sediment-laden runoff and trap the sediment in order to protect drainage ways, properties, and rights-of-way below the sediment trap from sedimentation. Catch basin outlet, grass outlet, and stone outlet sediment traps will be used throughout the site at the locations shown on the Sediment and Erosion Control Plans.

D. **Diversion Swales:**

A temporary excavated drainage way. The purpose of a temporary swale is to prevent runoff from entering disturbed areas by intercepting and diverting it to a stabilized outlet or to intercept sediment laden water and divert it to a sediment trapping device. Diversion swales will be used for diverting clean runoff around the project area and for intercept sediment laden runoff and directing it to sediment traps. Diversion swales will be placed as shown on the Sediment and Erosion Control Plans.

- E. **Water Bars**
A ridge or ridge and channel constructed diagonally across a sloping road or utility right-of-way that is subject to erosion. The purpose is to limit the accumulation of erosive velocity of water by diverting surface runoff at pre-designed intervals. A water bar will be used in the location shown on the Sediment and Erosion Control Plans
- F. **Storm Drain Inlet Protection:**
A temporary, somewhat permeable barrier, installed around inlets in the form of a fence, berm, or excavation around an opening, trapping water and thereby reducing the sediment content of sediment laden water by settling. The purpose is to prevent heavily sediment laden water from entering a storm drain system through inlets. Curb drop, filter fabric drop, and excavated drop inlet protection will be used throughout the site. Inlet protection will only be used in road areas before pavement is placed. Locations of inlet protection are shown on Sediment and Erosion Control Plans.
- G. **Level Spreaders:**
A temporary non-erosive outlet for concentrated runoff, constructed to disperse flow uniformly across a slope. The purpose is to convert concentrated flow to sheet flow and release it uniformly over a stabilized area. Level spreaders will be used at the ends of diversion swales used for diverting clean runoff around the project area. Level spreader locations are shown on the Sediment and Erosion Control Plans.
- H. **Slope Stabilization Matting:**
Matting made synthetic or natural fibers that is placed on steep slopes to allow newly planted vegetation to take root and protect the slope from erosion before vegetation is fully established. Locations of slope stabilization matting are shown on Sediment and Erosion Control Plans.
- I. **Rock Outlet Protection:**
A section of rock protection placed at the outlet of the culverts, conduits, or channels. The purpose of the rock outlet protection is to reduce the depth, velocity, and energy of water, such that the flow will not erode the receiving downstream reach. Rock outlet protection is proposed at all pipe discharge points. See the Site Plans for locations of rock outlet protection.
- J. **Check Dams:**
Small barriers or dams constructed of stone, bagged sand or gravel, or other durable material across a drainage way. See the Site Plans for locations of check dams.

X. IMPLEMENTATION SCHEDULE & MAINTENANCE

A. **Schedule**

As part of the development of the Erosion and Sediment Control Plans for the projects, preparation of construction sequencing was completed to ensure water quality discharges are maintained during construction. Construction for each project will be done independently, though

the Crystal Run Healthcare project must be constructed first to provide the stormwater pond and stormwater pond outlet. The following construction schedules for implementing stormwater management during construction are proposed. Please refer to the Site Plans for each project for specific sequencing and scheduling.

Crystal Run Healthcare construction sequence:

1. Pre-construction meeting: Before construction activities an evaluation of the site will be performed with the site contractor, Town personnel and site design engineer to discuss general construction procedures and sequencing. During this meeting sensitive areas of the property shall be delineated and marked-out with orange construction fence (i.e.: trees, wetlands, wells, etc.).
2. Delineate total site disturbance limits: Placement of orange construction fencing along the limit of disturbance throughout the site. Signs shall be placed every 100 feet along the City of Newburgh boundary stating "CITY OF NEWBURGH WATER SUPPLY. DO NOT ENTER."
3. Protect existing buffers: Place erosion control devices (silt fencing, diversion berms, etc.) upstream of any existing watercourse within or outside of construction areas, prior to the start of any construction.
4. The owner or operator shall have a qualified inspector conduct at least two (2) site inspections in accordance with Part IV.C. every seven (7) calendar days, for as long as greater than five (5) acres of soil remain disturbed. The two (2) inspections shall be separated by a minimum of two (2) full calendar days.
5. Construction entrances/siltation controls: a temporary construction entrance will be installed at the each of the entrances to the site on NYS Route 300 and Old Little Britain Road as shown on the Site Plans. In addition, any other siltation control devices, as shown on the erosion control plan are to be installed adjacent to the temporary entrance and staging area.
6. Construction of temporary sediment trap: Construction of the temporary sediment trap prior to the start of any major earthwork movement or site construction.
7. Construction of temporary diversion swales: The installation of temporary diversion swales to be used to convey stormwater to the sediment trap shall be completed. Water bars will be installed along the entrance road as needed to direct runoff to the temporary diversion swale.
8. Staging area: The staging area will be graded for storage of equipment and placement of construction trailers.
9. Strip topsoil: Topsoil will be stripped from the active work areas and will be stockpiled for later reuse.
10. Land grading: Bulk soil grading will commence. At this time, temporary stockpile areas should be utilized. The proposed building pad will be graded and stone base will be spread.

11. Retaining walls: Begin construction of on-site retaining walls. Walls to be installed concurrently with land grading.
12. Building foundation construction: Upon completion of grading in building footprint area, building foundation construction will commence.
13. Utility installation: Install water, sewer, and stormwater throughout the project. Inlet protection will be installed at all stormwater catch basins.
14. Stormwater installation: Install porous pavement areas and bio-retention areas when all contributing areas have been stabilized. Convert sediment trap to stormwater pond. Riprap outlet protection areas will be installed.
15. Pavement construction: Construct paved parking and access areas.
16. Erosion control practice removal: Remove any remaining erosion control practices including inlet protection, and temporary diversions swales when areas have been temporarily stabilized.
17. Landscaping and final stabilization: All open areas to be stabilized with topsoil and seeded as per the seeding schedule specified on the erosion and sediment control plans. Removal of all temporary measures, flushing/cleaning of all catch basins and pipe, and removal and disposal of all trapped sediment on site shall be completed.
18. Final site inspection and certification: At the end of construction a site evaluation of the site will be performed with site contractor, Town personnel, and site engineer to ensure that all stormwater facilities were constructed as per the SWPPP design and that the site has been stabilized. A Notice of Termination will be submitted to the NYSDEC.

Britain Plaza construction sequence:

1. Pre-construction meeting: Before construction activities an evaluation of the site will be performed with the site contractor, Town personnel and site design engineer to discuss general construction procedures and sequencing. During this meeting sensitive areas of the property shall be delineated and marked-out with orange construction fence (i.e.: trees, wetlands, wells, etc.).
2. Delineate total site disturbance limits: Placement of orange construction fencing along the limit of disturbance throughout the site.
3. Protect existing buffers: Place erosion control devices (silt fencing, diversion berms, etc.) upstream of any existing watercourse within or outside of construction areas, prior to the start of any construction.
4. Construction entrances/siltation controls: a temporary construction entrance will be installed at entrance to the site through the Crystal Run Healthcare property as shown on the Site Plans. In

addition, any other siltation control devices, as shown on the erosion control plan are to be installed adjacent to the temporary entrance and staging area.

5. Construction of temporary sediment trap: Construction of the temporary sediment trap prior to the start of any major earthwork movement or site construction.
6. Construction of temporary diversion swales: The installation of temporary diversion swales to be used to convey stormwater to the sediment trap shall be completed.
7. Staging area: The staging area will be graded for storage of equipment and placement of construction trailers.
8. Strip topsoil: Topsoil will be stripped from the active work areas and will be stockpiled for later reuse.
9. Land grading: Bulk soil grading will commence. At this time, temporary stockpile areas should be utilized. The proposed building pad will be graded and stone base will be spread.
10. Building foundation construction: Upon completion of grading in building footprint area, building foundation construction will commence.
11. Utility installation: Install water, sewer, and stormwater throughout the project. Inlet protection will be installed at all stormwater catch basins.
12. Stormwater installation: Convert sediment trap to stormwater pond.
13. Pavement construction: Construct paved parking and access areas.
14. Erosion control practice removal: Remove any remaining erosion control practices including inlet protection, and temporary diversions swales when areas have been temporarily stabilized.
15. Landscaping and final stabilization: All open areas to be stabilized with topsoil and seeded as per the seeding schedule specified on the erosion and sediment control plans. Removal of all temporary measures, flushing/cleaning of all catch basins and pipe, and removal and disposal of all trapped sediment on site shall be completed.
16. Final site inspection and certification: At the end of construction a site evaluation of the site will be performed with site contractor, Town personnel, and site engineer to ensure that all stormwater facilities were constructed as per the SWPPP design and that the site has been stabilized. A Notice of Termination will be submitted to the NYSDEC.

Please refer to the Erosion and Sediment Control Plans within the Site Plans for construction notes and seeding schedule for disturbance and final stabilization.

B. Pollution Prevention Measures:

All pollutants, including waste materials and demolition debris, that occur onsite shall be handled and disposed of in a manner conforms to all applicable Federal and State regulations that does not cause contamination of stormwater. Good housekeeping and preventative measures will be taken to ensure that the site will be kept clean, well organized, and free of debris. If required, BMPs to be implemented to control specific sources of pollutants are discussed below.

Vehicles, construction equipment, and/or petroleum product storage/dispensing:

1. All vehicles, equipment, and petroleum product storage/dispensing areas will be observed regularly during site observations to detect any leaks or spills, and to identify maintenance needs to prevent leaks or spills.
2. On-site fueling tanks and petroleum product storage containers shall include secondary containment.
3. Spill prevention measures, such as drip pans, will be used when conducting maintenance and repair of vehicles or equipment.
4. In order to perform emergency repairs on site, temporary plastic will be placed beneath and, if raining, over the vehicle.
5. Contaminated surfaces shall be cleaned immediately following any discharge or spill incident. Contaminated soil shall be removed from site and disposed of in accordance with all current Federal and State Regulations.

Chemical storage:

1. Any chemicals stored in the construction areas will conform to the appropriate manufacturer's recommendations and or the appropriate State/Federal Regulations. All chemicals shall have cover, containment, and protection provided on site, per all Federal and NYSDEC regulations.
2. Application of agricultural chemicals, including fertilizers and pesticides, shall be conducted in a manner and at application rates that will not result in loss of chemical to stormwater runoff. Manufacturers' recommendations for application procedures and rates shall be followed.

Demolition:

1. Dust released from demolished sidewalks, buildings, structures or on site grading operations will be controlled using Dust Control measures as specified in the N.Y.S. Erosion and Sediment Control Specification Manual.
2. Storm drain inlets vulnerable to stormwater discharge carrying dust, soil, or debris will be protected using Storm Drain Inlet Protection.

3. Process water and slurry resulting from saw cutting and surfacing operations will be prevented from entering the waters of the State by implementing Saw cutting and Surfacing Pollution Prevention measures.

Concrete and grout:

1. Process water and slurry resulting from concrete work will be prevented from entering the waters of the State by implementing Concrete Handling measures.

Sanitary wastewater:

1. Portable sanitation facilities will be firmly secured, regularly maintained, and emptied when necessary.
2. Wheel wash or tire bath wastewater shall be discharged to a temporary erosion and sediment control facility which has been constructed on site.

Solid Waste:

1. Solid waste will be stored in secure, clearly marked containers.

Litter/Trash:

1. Litter and Trash shall be cleaned and disposed of in secure clearly marked dumpsters or trash receptacles.
2. Site is to be cleaned daily of debris and disposed of on a daily basis.

Other:

1. Other BMPs will be administered as necessary to address any other additional pollutant sources on site.

C. Maintenance (Construction/Long-Term)

1. The property owners/operators will be responsible for the maintenance and operation of all site related stormwater management facilities during construction and the property owner will be responsible for long-term maintenance. Maintenance activities will be shared between the property owners through a legal agreement. The property owners shall also prepare a maintenance agreement with the Town of Newburgh and said agreement shall also provide a maintenance schedule for the facilities installed on the project site. A standard maintenance agreement has been included within Appendix F of this report.

2. A stand alone Operation and Maintenance Plan will be prepared prior to filing of the NOTs and will include the following: schedules, procedures, forms for inspections, maps showing stormwater practice areas, and the maintenance agreement. Please refer to Appendix F for standard Inspection and Maintenance Forms.
3. Construction and long-term maintenance shall be carried out in accordance with the following notes:
 - a. Stormwater Pond: Inspection shall be made weekly by a licensed professional and after every ½” rainfall event by the owner or contractor during construction. During the first growing season inspections shall be conducted monthly and annually thereafter. The following tasks shall be performed as needed:
 - (1) Removal of accumulated sediment and cleaning and/or restoration of the sediment forebays every 5 years or whenever accumulated sediment reaches a volume of 50% of the available capacity.
 - (2) Restoration of any disturbed plant material and any eroded embankments as needed.
 - (3) Removal of accumulated debris within the basin and at all inlet and outfall structures as needed.
 - (4) Annual inspection of the outlet structure to ensure structural stability and removal of any accumulated trash within the structure.
 - (5) Mowing of the berm and surrounding area of the basins twice a year or as necessary. Removal of any fallen trees or limbs.
 - b. Bio-retention Area: Inspection shall be made weekly by a licensed professional and after every ½” rainfall event by the owner or contractor during construction. During the first growing season inspections shall be conducted monthly and annually thereafter. The following tasks shall be performed as needed:
 - (1) Removal of accumulated sediment and cleaning and/or restoration of the filter bed areas whenever accumulated sediment reaches a volume of 50% of the available capacity.
 - (2) Restoration of any disturbed plant material and any eroded embankments.
 - (3) Removal of accumulated debris within the filter bed areas and at all inlet and outfall structures.
 - (4) Annual mowing of the berm and surrounding area of the basins. Removal of any fallen trees or limbs. No mowing or trimming is to occur within the constructed area

of the wetland. Replacement of proposed plants shall occur if more than 50% of the coverage of the facility is not achieved.

- c. Porous Pavement: Pavement shall be protected from silt and sediment during construction of surrounding areas, if possible, the asphalt pavement should be installed after stabilization of surrounding areas. During winter conditions, sand and salt should be avoided being utilized to the porous pavement sections. The following tasks shall be performed as needed:
 - (1) Clean debris and sediment from pavement monthly.
 - (2) Ensure pavement fully drains after storms monthly and after storms greater than 0.5 inches.
 - (3) Mow and seed bare areas upland and adjacent to the pavement as needed.
 - (4) Vacuum pavement surface 2 to 3 times a year depending on site conditions.
 - (5) Inspection pavement surface for deterioration or spalling.
- d. Swales: Inspection shall be made weekly and after every ½" rainfall event during construction. During the first growing season inspections shall be conducted monthly, and on an annual basis thereafter. The following tasks shall be performed as needed:
 - (1) Removal of accumulated sediment and cleaning and/or restoration whenever accumulated sediment reaches a volume of 50% of the available capacity.
 - (2) Restoration of any eroded embankments. Infrequent reshaping of the swale line should be completed as needed.
 - (3) Removal of accumulated debris/trash within the swale and at all inlet and outfall structures.
 - (4) Seasonal mowing of the swale bottom and surrounding side slopes. Removal of any fallen trees or limbs. Replacement and/or restoration of proposed grasses shall occur if more than 50% of the coverage of the facility is not achieved. Grasses should be kept at a maximum height of 6" – 8".
- e. Roadway Pavements: Roadway pavements shall be swept on a regular basis to remove accumulated sediment. Collected sediment shall be removed, which will not allow the re-entrance of silt into the storm water drainage system.
- f. Catch Basins: Catch basins shall be flushed and cleaned of any collected sediment within the bottom of the basin approximately every 4-5 years. Collected sediment shall be removed, which will not allow the reentrance of silt into the storm water drainage system.

g. Vegetative Stabilization:

- (1) All vegetative planting on areas that have been disturbed and are finish graded shall be inspected monthly during the first growing season and annually thereafter. Planting (or seeding) shall be maintained in viable conditions to stabilize the soil and to prevent soil erosion. Restore all site planting and/or seeding which has been damaged to a viable condition.
- (2) If vegetative stabilization has been damaged from storm water erosion, correct upstream conditions that caused the erosion. Check dams may be required in drainage ways and stone outfall aprons may be required to be repaired on storm water outfall sites.

h. Temporary erosion and sediment control maintenance:

- (1) All erosion and sediment control practices will be checked for stability and operation following every runoff-producing rainfall, but in no case less than once every week. Any needed repairs will be made immediately to maintain all practices as designed and installed for their appropriate phase of the project.
- (2) Sediment will be removed from the sediment trap and inlet protection device when storage capacity has been approximately 50% filled.
- (3) Sediment will be removed from behind the sediment fence when it becomes about 0.5 ft deep at the fence. The sediment fence will be repaired as necessary to maintain a barrier.

XI. ANALYSIS AND CONCLUSION

As can be seen from the calculations provided above the proposed tree plantings, bio-retention areas, rain gardens, and porous pavement parking areas provide water quality treatment and runoff reduction in accordance with the stormwater quality management guidelines set forth by the NYSDEC. Due to the site's location in the watershed for Lake Washington, the site has also been designed to provide more than 110% of the required water quality volume. Also the proposed stormwater pond provides water quality treatment and sufficient quantity control for both projects. The proposed stormwater practices and the post-development layout of the development show that peak stormwater runoff flowrates at the study points decrease for all analyzed storms. Based upon the results of this analysis, the site has demonstrated the ability to meet all requirements for stormwater quantity and quality and an impact to the existing watershed and downstream waters should be negligible.

Table 4 below summarizes the pre- and post-development discharges for the development. Please refer to Appendix B for detailed analysis and calculations of the individual watershed subareas.

		1 Year Peak Runoff (cfs)	10 Year Peak Runoff (cfs)	100 Year Peak Runoff (cfs)
Condition				
Study Point A	Pre-Development	6.94	17.48	27.85
	Post-Development	1.30	16.64	27.84
	Difference	-5.64 (-81.3%)	-0.84 (-4.8%)	-0.01 (-0.0%)
Study Point B	Pre-Development	0.93	2.47	3.99
	Post-Development	0.22	0.62	1.03
	Difference	-0.71 (-76.3%)	-1.85 (-74.9%)	-2.96 (-74.2%)
Study Point C	Pre-Development	1.96	4.81	7.58
	Post-Development	0.24	0.68	1.13
	Difference	-1.72 (-87.8%)	-4.13 (-85.9%)	-6.45 (-85.1%)

Table 4: Comparison of Pre- and Post-Development Conditions at Study Point

By implementing both the Stormwater Pollution Prevention Plan and Erosion and Sediment Control Plans during the construction of the proposed projects, current New York State Department of Environmental Conservation and Town regulations can be met. However, the owner and contractor are responsible for implementation of the project's erosion and sedimentation controls and any required maintenance. In addition, this also includes filing the NOI for each project and meeting all requirements of the General Permit, including necessary site assessment and inspections.

Respectfully submitted,

LANC & TULLY, P.C.

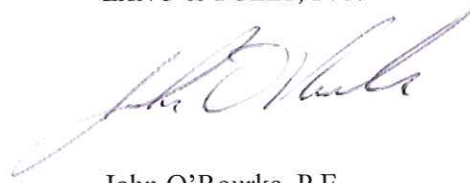

John O'Rourke, P.E.

LIST OF APPENDICES

- APPENDIX A: SITE LOCATION MAP
SOILS REPORT FOR PROJECT
- APPENDIX B: PRE/POST-DEVELOPMENT WATERSHED MODELS
- APPENDIX C: PRE/POST-DEVELOPMENT WATERSHED MAPS
- APPENDIX D: CALCULATIONS:
WATER QUALITY/RUNOFF REDUCTION VOLUME
CHANNEL PROTECTION VOLUME
STORMWATER PRACTICE DESIGN
- APPENDIX E: EXCERPTS FROM THE “NEW YORK STATE STORMWATER
DESIGN MANUAL”
CONSTRUCTION SPECIFICATIONS
- APPENDIX F: STANDARD CONSTRUCTION INSPECTION FORMS
STANDARD MAINTENANCE INSPECTION FORMS
- APPENDIX G: NOTICE OF INTENT
NOTICE OF TERMINATION
MS4 SWPPP ACCEPTANCE FORM
- APPENDIX H: CONSTRUCTION SITE LOG BOOK
CONTRACTOR’S CERTIFICATION FORM
- APPENDIX I: PIPE SIZING ANALYSIS
- APPENDIX J: TEST PIT INFORMATION
- APPENDIX K: SITE PLANS

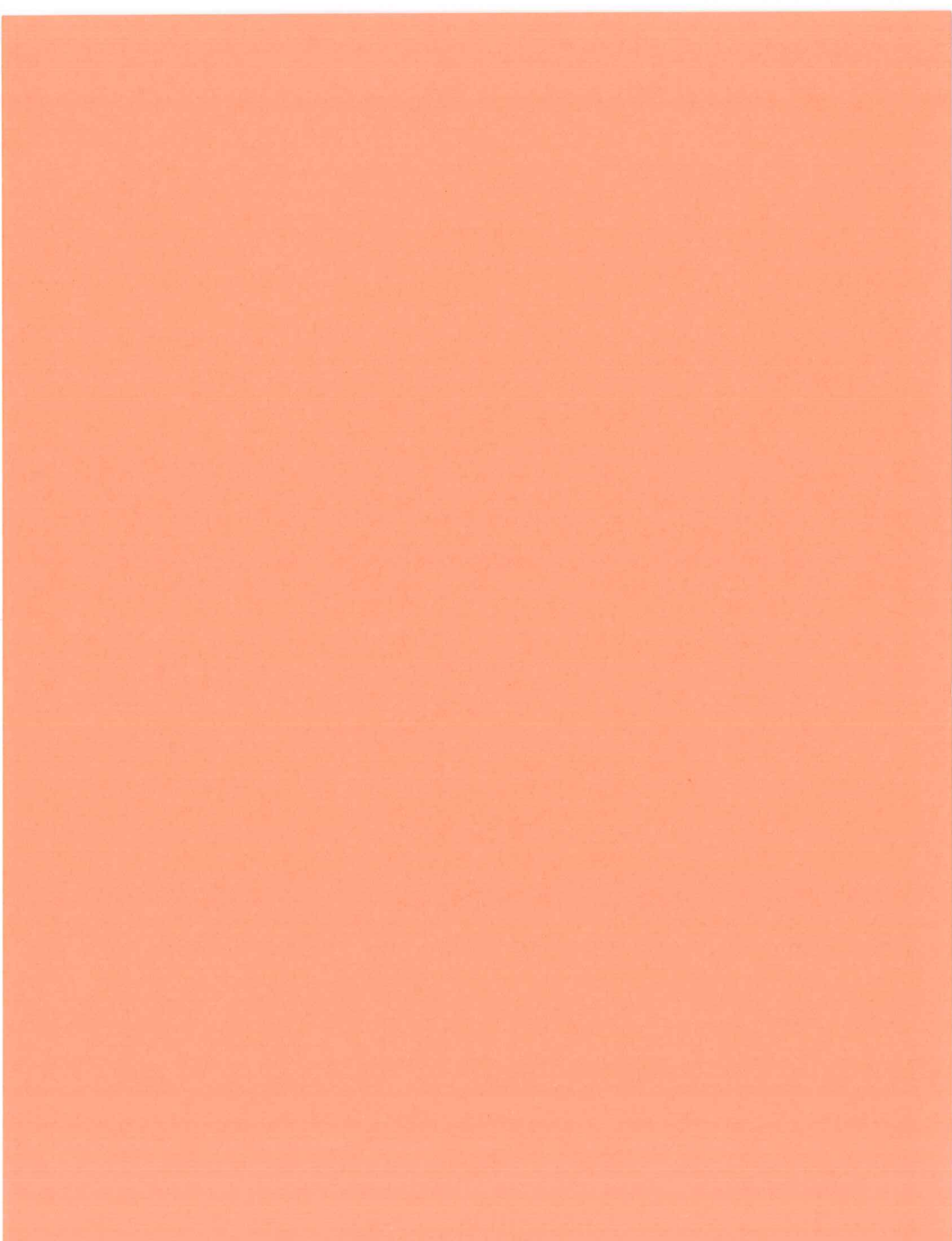

APPENDIX A

SITE LOCATION MAP
SOILS REPORT FOR PROJECT

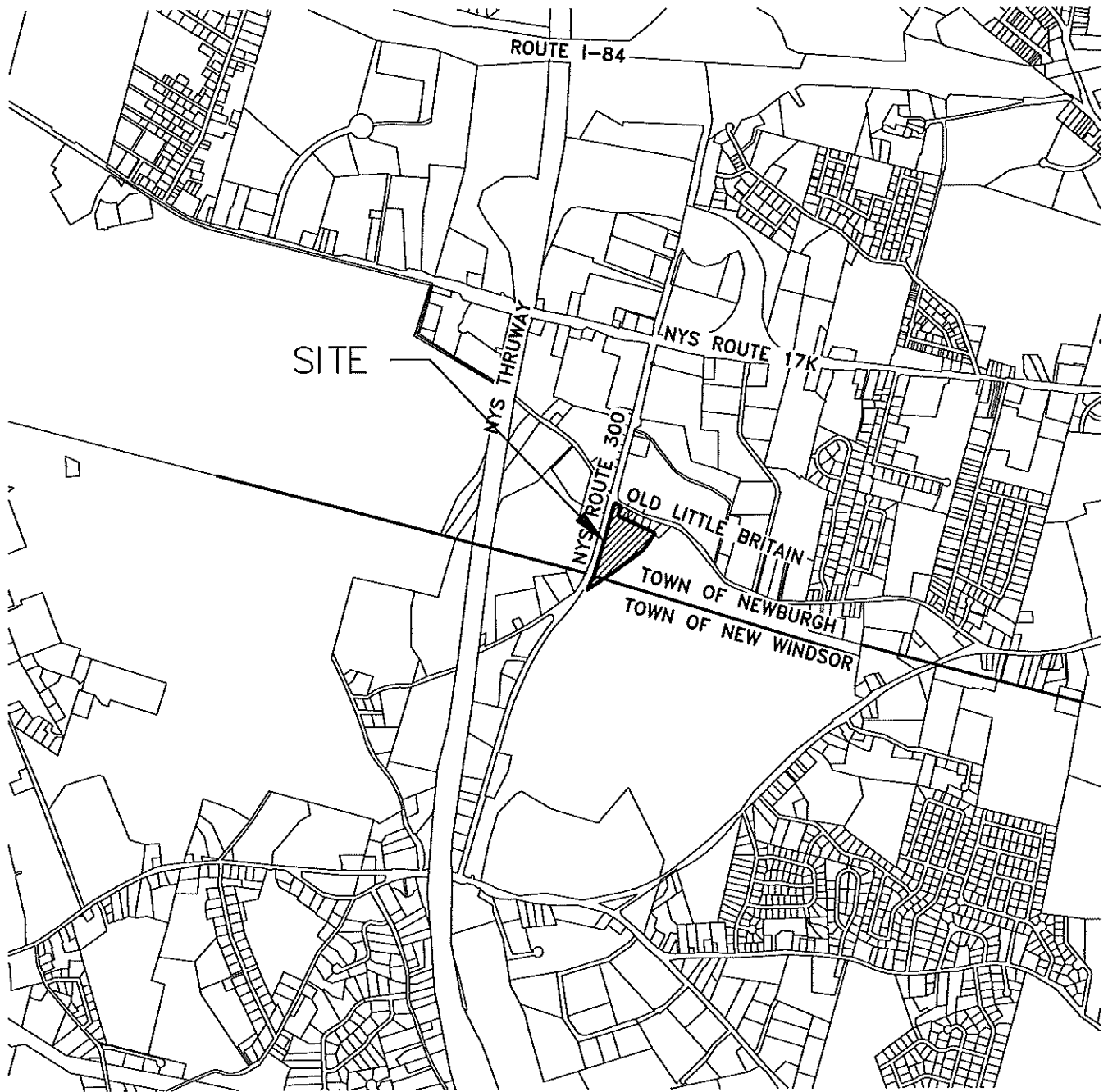

COPYRIGHT 2013, LANC & TULLY, P.C.

LANC & TULLY

ENGINEERING AND SURVEYING, P.C.

P.O. Box 687, Rt. 207
 Goshen, N.Y. 10924
 (845) 294-3700

SITE LOCATION MAP

CRH REALTY VIII, LLC
/ BRITAIN PLAZA
 TOWN OF NEWBURGH
 ORANGE COUNTY, NEW YORK

Date: DECEMBER 5, 2013

Revisions: FEBRUARY 12, 2014

CAD File: 120100-DRAINAGE-COMBINED

Layout: LOCATION

Sheet No.: 1 OF 4

Drawn By: ESR

Checked By:

Scale: 1" = 2,000'

Tax Map No.: 97-3-1,2,6,7,8,26
 4-1-72.2 NW

Drawing No.: C3D
 F - 12 - 0100 - 01



United States
Department of
Agriculture



NRCS

Natural
Resources
Conservation
Service

A product of the National
Cooperative Soil Survey,
a joint effort of the United
States Department of
Agriculture and other
Federal agencies, State
agencies including the
Agricultural Experiment
Stations, and local
participants

Custom Soil Resource Report for Orange County, New York



Preface

Soil surveys contain information that affects land use planning in survey areas. They highlight soil limitations that affect various land uses and provide information about the properties of the soils in the survey areas. Soil surveys are designed for many different users, including farmers, ranchers, foresters, agronomists, urban planners, community officials, engineers, developers, builders, and home buyers. Also, conservationists, teachers, students, and specialists in recreation, waste disposal, and pollution control can use the surveys to help them understand, protect, or enhance the environment.

Various land use regulations of Federal, State, and local governments may impose special restrictions on land use or land treatment. Soil surveys identify soil properties that are used in making various land use or land treatment decisions. The information is intended to help the land users identify and reduce the effects of soil limitations on various land uses. The landowner or user is responsible for identifying and complying with existing laws and regulations.

Although soil survey information can be used for general farm, local, and wider area planning, onsite investigation is needed to supplement this information in some cases. Examples include soil quality assessments (<http://soils.usda.gov/sqi/>) and certain conservation and engineering applications. For more detailed information, contact your local USDA Service Center (<http://offices.sc.egov.usda.gov/locator/app?agency=nrcs>) or your NRCS State Soil Scientist (http://soils.usda.gov/contact/state_offices/).

Great differences in soil properties can occur within short distances. Some soils are seasonally wet or subject to flooding. Some are too unstable to be used as a foundation for buildings or roads. Clayey or wet soils are poorly suited to use as septic tank absorption fields. A high water table makes a soil poorly suited to basements or underground installations.

The National Cooperative Soil Survey is a joint effort of the United States Department of Agriculture and other Federal agencies, State agencies including the Agricultural Experiment Stations, and local agencies. The Natural Resources Conservation Service (NRCS) has leadership for the Federal part of the National Cooperative Soil Survey.

Information about soils is updated periodically. Updated information is available through the NRCS Soil Data Mart Web site or the NRCS Web Soil Survey. The Soil Data Mart is the data storage site for the official soil survey information.

The U.S. Department of Agriculture (USDA) prohibits discrimination in all its programs and activities on the basis of race, color, national origin, age, disability, and where applicable, sex, marital status, familial status, parental status, religion, sexual orientation, genetic information, political beliefs, reprisal, or because all or a part of an individual's income is derived from any public assistance program. (Not all prohibited bases apply to all programs.) Persons with disabilities who require alternative means

for communication of program information (Braille, large print, audiotape, etc.) should contact USDA's TARGET Center at (202) 720-2600 (voice and TDD). To file a complaint of discrimination, write to USDA, Director, Office of Civil Rights, 1400 Independence Avenue, S.W., Washington, D.C. 20250-9410 or call (800) 795-3272 (voice) or (202) 720-6382 (TDD). USDA is an equal opportunity provider and employer.

Contents

Preface	2
How Soil Surveys Are Made	5
Soil Map	7
Soil Map.....	8
Legend.....	9
Map Unit Legend.....	10
Map Unit Descriptions.....	10
Orange County, New York.....	12
ErA—Erie gravelly silt loam, 0 to 3 percent slopes.....	12
MdB—Mardin gravelly silt loam, 3 to 8 percent slopes.....	13
MdC—Mardin gravelly silt loam, 8 to 15 percent slopes.....	14
Soil Information for All Uses	16
Soil Properties and Qualities.....	16
Soil Qualities and Features.....	16
Hydrologic Soil Group.....	16
References	21

How Soil Surveys Are Made

Soil surveys are made to provide information about the soils and miscellaneous areas in a specific area. They include a description of the soils and miscellaneous areas and their location on the landscape and tables that show soil properties and limitations affecting various uses. Soil scientists observed the steepness, length, and shape of the slopes; the general pattern of drainage; the kinds of crops and native plants; and the kinds of bedrock. They observed and described many soil profiles. A soil profile is the sequence of natural layers, or horizons, in a soil. The profile extends from the surface down into the unconsolidated material in which the soil formed or from the surface down to bedrock. The unconsolidated material is devoid of roots and other living organisms and has not been changed by other biological activity.

Currently, soils are mapped according to the boundaries of major land resource areas (MLRAs). MLRAs are geographically associated land resource units that share common characteristics related to physiography, geology, climate, water resources, soils, biological resources, and land uses (USDA, 2006). Soil survey areas typically consist of parts of one or more MLRA.

The soils and miscellaneous areas in a survey area occur in an orderly pattern that is related to the geology, landforms, relief, climate, and natural vegetation of the area. Each kind of soil and miscellaneous area is associated with a particular kind of landform or with a segment of the landform. By observing the soils and miscellaneous areas in the survey area and relating their position to specific segments of the landform, a soil scientist develops a concept, or model, of how they were formed. Thus, during mapping, this model enables the soil scientist to predict with a considerable degree of accuracy the kind of soil or miscellaneous area at a specific location on the landscape.

Commonly, individual soils on the landscape merge into one another as their characteristics gradually change. To construct an accurate soil map, however, soil scientists must determine the boundaries between the soils. They can observe only a limited number of soil profiles. Nevertheless, these observations, supplemented by an understanding of the soil-vegetation-landscape relationship, are sufficient to verify predictions of the kinds of soil in an area and to determine the boundaries.

Soil scientists recorded the characteristics of the soil profiles that they studied. They noted soil color, texture, size and shape of soil aggregates, kind and amount of rock fragments, distribution of plant roots, reaction, and other features that enable them to identify soils. After describing the soils in the survey area and determining their properties, the soil scientists assigned the soils to taxonomic classes (units). Taxonomic classes are concepts. Each taxonomic class has a set of soil characteristics with precisely defined limits. The classes are used as a basis for comparison to classify soils systematically. Soil taxonomy, the system of taxonomic classification used in the United States, is based mainly on the kind and character of soil properties and the arrangement of horizons within the profile. After the soil scientists classified and named the soils in the survey area, they compared the

Custom Soil Resource Report

individual soils with similar soils in the same taxonomic class in other areas so that they could confirm data and assemble additional data based on experience and research.

The objective of soil mapping is not to delineate pure map unit components; the objective is to separate the landscape into landforms or landform segments that have similar use and management requirements. Each map unit is defined by a unique combination of soil components and/or miscellaneous areas in predictable proportions. Some components may be highly contrasting to the other components of the map unit. The presence of minor components in a map unit in no way diminishes the usefulness or accuracy of the data. The delineation of such landforms and landform segments on the map provides sufficient information for the development of resource plans. If intensive use of small areas is planned, onsite investigation is needed to define and locate the soils and miscellaneous areas.

Soil scientists make many field observations in the process of producing a soil map. The frequency of observation is dependent upon several factors, including scale of mapping, intensity of mapping, design of map units, complexity of the landscape, and experience of the soil scientist. Observations are made to test and refine the soil-landscape model and predictions and to verify the classification of the soils at specific locations. Once the soil-landscape model is refined, a significantly smaller number of measurements of individual soil properties are made and recorded. These measurements may include field measurements, such as those for color, depth to bedrock, and texture, and laboratory measurements, such as those for content of sand, silt, clay, salt, and other components. Properties of each soil typically vary from one point to another across the landscape.

Observations for map unit components are aggregated to develop ranges of characteristics for the components. The aggregated values are presented. Direct measurements do not exist for every property presented for every map unit component. Values for some properties are estimated from combinations of other properties.

While a soil survey is in progress, samples of some of the soils in the area generally are collected for laboratory analyses and for engineering tests. Soil scientists interpret the data from these analyses and tests as well as the field-observed characteristics and the soil properties to determine the expected behavior of the soils under different uses. Interpretations for all of the soils are field tested through observation of the soils in different uses and under different levels of management. Some interpretations are modified to fit local conditions, and some new interpretations are developed to meet local needs. Data are assembled from other sources, such as research information, production records, and field experience of specialists. For example, data on crop yields under defined levels of management are assembled from farm records and from field or plot experiments on the same kinds of soil.

Predictions about soil behavior are based not only on soil properties but also on such variables as climate and biological activity. Soil conditions are predictable over long periods of time, but they are not predictable from year to year. For example, soil scientists can predict with a fairly high degree of accuracy that a given soil will have a high water table within certain depths in most years, but they cannot predict that a high water table will always be at a specific level in the soil on a specific date.

After soil scientists located and identified the significant natural bodies of soil in the survey area, they drew the boundaries of these bodies on aerial photographs and identified each as a specific map unit. Aerial photographs show trees, buildings, fields, roads, and rivers, all of which help in locating boundaries accurately.

Soil Map

The soil map section includes the soil map for the defined area of interest, a list of soil map units on the map and extent of each map unit, and cartographic symbols displayed on the map. Also presented are various metadata about data used to produce the map, and a description of each soil map unit.

Custom Soil Resource Report Soil Map

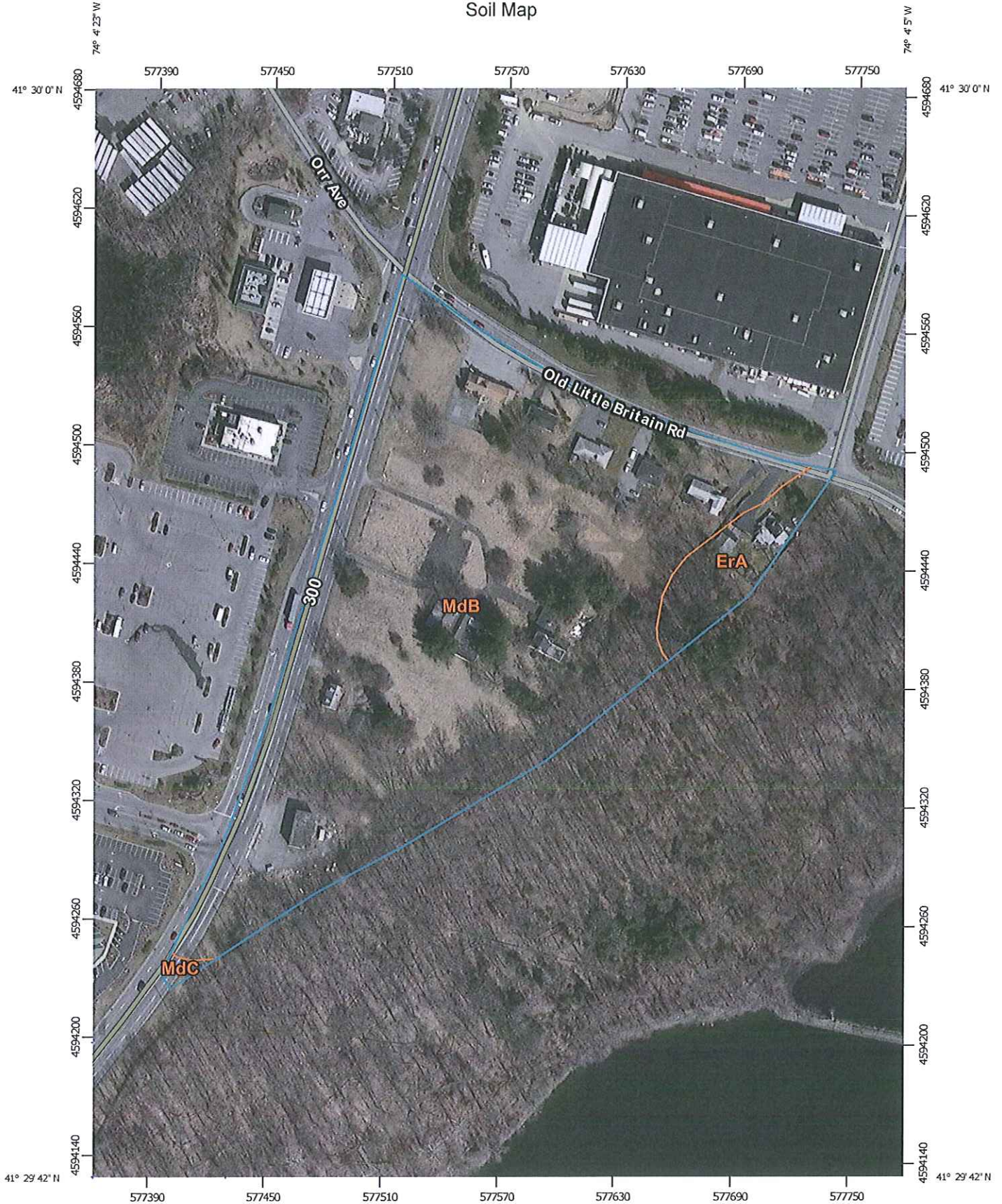





























Map Scale: 1:2,690 if printed on A portrait (8.5" x 11") sheet.



Map projection: Web Mercator Corner coordinates: WGS84 Edge ticks: UTM Zone 18N WGS84

MAP LEGEND

-  Area of Interest (AOI)
-  Area of Interest (AOI)
- Soils**
-  Soil Map Unit Polygons
-  Soil Map Unit Lines
-  Soil Map Unit Points
- Special Point Features**
-  Blowout
-  Borrow Pit
-  Clay Spot
-  Closed Depression
-  Gravel Pit
-  Gravelly Spot
-  Landfill
-  Lava Flow
-  Marsh or swamp
-  Mine or Quarry
-  Miscellaneous Water
-  Perennial Water
-  Rock Outcrop
-  Saline Spot
-  Sandy Spot
-  Severely Eroded Spot
-  Sinkhole
-  Slide or Slip
-  Sodic Spot
-  Spoil Area
-  Stony Spot
-  Very Stony Spot
-  Wet Spot
-  Other
-  Special Line Features
- Water Features**
-  Streams and Canals
- Transportation**
-  Rails
-  Interstate Highways
-  US Routes
-  Major Roads
-  Local Roads
- Background**
-  Aerial Photography

MAP INFORMATION

The soil surveys that comprise your AOI were mapped at 1:15,800.

Warning: Soil Map may not be valid at this scale.

Enlargement of maps beyond the scale of mapping can cause misunderstanding of the detail of mapping and accuracy of soil line placement. The maps do not show the small areas of contrasting soils that could have been shown at a more detailed scale.

Please rely on the bar scale on each map sheet for map measurements.

Source of Map: Natural Resources Conservation Service
 Web Soil Survey URL: <http://websoilsurvey.nrcs.usda.gov>
 Coordinate System: Web Mercator (EPSG:3857)

Maps from the Web Soil Survey are based on the Web Mercator projection, which preserves direction and shape but distorts distance and area. A projection that preserves area, such as the Albers equal-area conic projection, should be used if more accurate calculations of distance or area are required.

This product is generated from the USDA-NRCS certified data as of the version date(s) listed below.

Soil Survey Area: Orange County, New York
 Survey Area Data: Version 13, Sep 21, 2012

Soil map units are labeled (as space allows) for map scales 1:50,000 or larger.

Date(s) aerial images were photographed: Mar 26, 2011—Apr 16, 2012

The orthophoto or other base map on which the soil lines were compiled and digitized probably differs from the background imagery displayed on these maps. As a result, some minor shifting of map-unit boundaries may be evident.

Map Unit Legend

Orange County, New York (NY071)			
Map Unit Symbol	Map Unit Name	Acres in AOI	Percent of AOI
ErA	Erie gravelly silt loam, 0 to 3 percent slopes	0.8	6.2%
MdB	Mardin gravelly silt loam, 3 to 8 percent slopes	11.5	93.3%
MdC	Mardin gravelly silt loam, 8 to 15 percent slopes	0.1	0.5%
Totals for Area of Interest		12.4	100.0%

Map Unit Descriptions

The map units delineated on the detailed soil maps in a soil survey represent the soils or miscellaneous areas in the survey area. The map unit descriptions, along with the maps, can be used to determine the composition and properties of a unit.

A map unit delineation on a soil map represents an area dominated by one or more major kinds of soil or miscellaneous areas. A map unit is identified and named according to the taxonomic classification of the dominant soils. Within a taxonomic class there are precisely defined limits for the properties of the soils. On the landscape, however, the soils are natural phenomena, and they have the characteristic variability of all natural phenomena. Thus, the range of some observed properties may extend beyond the limits defined for a taxonomic class. Areas of soils of a single taxonomic class rarely, if ever, can be mapped without including areas of other taxonomic classes. Consequently, every map unit is made up of the soils or miscellaneous areas for which it is named and some minor components that belong to taxonomic classes other than those of the major soils.

Most minor soils have properties similar to those of the dominant soil or soils in the map unit, and thus they do not affect use and management. These are called noncontrasting, or similar, components. They may or may not be mentioned in a particular map unit description. Other minor components, however, have properties and behavioral characteristics divergent enough to affect use or to require different management. These are called contrasting, or dissimilar, components. They generally are in small areas and could not be mapped separately because of the scale used. Some small areas of strongly contrasting soils or miscellaneous areas are identified by a special symbol on the maps. If included in the database for a given area, the contrasting minor components are identified in the map unit descriptions along with some characteristics of each. A few areas of minor components may not have been observed, and consequently they are not mentioned in the descriptions, especially where the pattern was so complex that it was impractical to make enough observations to identify all the soils and miscellaneous areas on the landscape.

The presence of minor components in a map unit in no way diminishes the usefulness or accuracy of the data. The objective of mapping is not to delineate pure taxonomic classes but rather to separate the landscape into landforms or landform segments that have similar use and management requirements. The delineation of such segments

Custom Soil Resource Report

on the map provides sufficient information for the development of resource plans. If intensive use of small areas is planned, however, onsite investigation is needed to define and locate the soils and miscellaneous areas.

An identifying symbol precedes the map unit name in the map unit descriptions. Each description includes general facts about the unit and gives important soil properties and qualities.

Soils that have profiles that are almost alike make up a *soil series*. Except for differences in texture of the surface layer, all the soils of a series have major horizons that are similar in composition, thickness, and arrangement.

Soils of one series can differ in texture of the surface layer, slope, stoniness, salinity, degree of erosion, and other characteristics that affect their use. On the basis of such differences, a soil series is divided into *soil phases*. Most of the areas shown on the detailed soil maps are phases of soil series. The name of a soil phase commonly indicates a feature that affects use or management. For example, Alpha silt loam, 0 to 2 percent slopes, is a phase of the Alpha series.

Some map units are made up of two or more major soils or miscellaneous areas. These map units are complexes, associations, or undifferentiated groups.

A *complex* consists of two or more soils or miscellaneous areas in such an intricate pattern or in such small areas that they cannot be shown separately on the maps. The pattern and proportion of the soils or miscellaneous areas are somewhat similar in all areas. Alpha-Beta complex, 0 to 6 percent slopes, is an example.

An *association* is made up of two or more geographically associated soils or miscellaneous areas that are shown as one unit on the maps. Because of present or anticipated uses of the map units in the survey area, it was not considered practical or necessary to map the soils or miscellaneous areas separately. The pattern and relative proportion of the soils or miscellaneous areas are somewhat similar. Alpha-Beta association, 0 to 2 percent slopes, is an example.

An *undifferentiated group* is made up of two or more soils or miscellaneous areas that could be mapped individually but are mapped as one unit because similar interpretations can be made for use and management. The pattern and proportion of the soils or miscellaneous areas in a mapped area are not uniform. An area can be made up of only one of the major soils or miscellaneous areas, or it can be made up of all of them. Alpha and Beta soils, 0 to 2 percent slopes, is an example.

Some surveys include *miscellaneous areas*. Such areas have little or no soil material and support little or no vegetation. Rock outcrop is an example.

Orange County, New York

ErA—Erie gravelly silt loam, 0 to 3 percent slopes

Map Unit Setting

Mean annual precipitation: 42 to 52 inches

Mean annual air temperature: 46 to 52 degrees F

Frost-free period: 135 to 215 days

Map Unit Composition

Erie and similar soils: 75 percent

Minor components: 25 percent

Description of Erie

Setting

Landform: Drumlinoid ridges, hills, till plains

Landform position (two-dimensional): Footslope, summit

Landform position (three-dimensional): Base slope

Down-slope shape: Concave

Across-slope shape: Linear

Parent material: Loamy till derived from siltstone, sandstone, shale, and limestone

Properties and qualities

Slope: 0 to 3 percent

Depth to restrictive feature: 10 to 21 inches to fragipan

Drainage class: Somewhat poorly drained

Capacity of the most limiting layer to transmit water (Ksat): Moderately low to moderately high (0.06 to 0.20 in/hr)

Depth to water table: About 6 to 18 inches

Frequency of flooding: None

Frequency of ponding: None

Calcium carbonate, maximum content: 15 percent

Available water capacity: Very low (about 2.5 inches)

Interpretive groups

Farmland classification: Farmland of statewide importance

Land capability (nonirrigated): 3w

Hydrologic Soil Group: D

Typical profile

0 to 10 inches: Gravelly silt loam

10 to 18 inches: Channery silt loam

18 to 56 inches: Channery silt loam

56 to 70 inches: Channery silt loam

Minor Components

Bath

Percent of map unit: 5 percent

Alden

Percent of map unit: 5 percent

Landform: Depressions

Swartswood

Percent of map unit: 5 percent

Custom Soil Resource Report

Landform: Depressions

Mardin

Percent of map unit: 5 percent

Wurtsboro

Percent of map unit: 5 percent

MdB—Mardin gravelly silt loam, 3 to 8 percent slopes

Map Unit Setting

Elevation: 800 to 1,800 feet

Mean annual precipitation: 42 to 52 inches

Mean annual air temperature: 46 to 52 degrees F

Frost-free period: 135 to 215 days

Map Unit Composition

Mardin and similar soils: 75 percent

Minor components: 25 percent

Description of Mardin

Setting

Landform: Drumlinoid ridges, hills, till plains

Landform position (two-dimensional): Summit

Landform position (three-dimensional): Crest

Down-slope shape: Concave

Across-slope shape: Convex

Parent material: Loamy till derived mainly from acid sedimentary rock

Properties and qualities

Slope: 3 to 8 percent

Depth to restrictive feature: 14 to 26 inches to fragipan

Drainage class: Moderately well drained

Capacity of the most limiting layer to transmit water (Ksat): Moderately low to moderately high (0.06 to 0.20 in/hr)

Depth to water table: About 18 to 24 inches

Frequency of flooding: None

Frequency of ponding: None

Available water capacity: Very low (about 2.5 inches)

Interpretive groups

Farmland classification: Farmland of statewide importance

Land capability (nonirrigated): 2w

Hydrologic Soil Group: D

Typical profile

0 to 8 inches: Gravelly silt loam

8 to 20 inches: Gravelly silt loam

20 to 60 inches: Channery silt loam

Minor Components

Bath

Percent of map unit: 5 percent

Swartswood

Percent of map unit: 5 percent

Lordstown

Percent of map unit: 5 percent

Wurtsboro

Percent of map unit: 5 percent

Erie

Percent of map unit: 5 percent

MdC—Mardin gravelly silt loam, 8 to 15 percent slopes

Map Unit Setting

Elevation: 800 to 1,800 feet

Mean annual precipitation: 42 to 52 inches

Mean annual air temperature: 46 to 52 degrees F

Frost-free period: 135 to 215 days

Map Unit Composition

Mardin and similar soils: 75 percent

Minor components: 25 percent

Description of Mardin

Setting

Landform: Drumlinoid ridges, hills, till plains

Landform position (two-dimensional): Summit

Landform position (three-dimensional): Crest

Down-slope shape: Concave

Across-slope shape: Convex

Parent material: Loamy till derived mainly from acid sedimentary rock

Properties and qualities

Slope: 8 to 15 percent

Depth to restrictive feature: 14 to 26 inches to fragipan

Drainage class: Moderately well drained

Capacity of the most limiting layer to transmit water (Ksat): Moderately low to moderately high (0.06 to 0.20 in/hr)

Depth to water table: About 18 to 24 inches

Frequency of flooding: None

Frequency of ponding: None

Available water capacity: Very low (about 2.3 inches)

Interpretive groups

Farmland classification: Farmland of statewide importance

Custom Soil Resource Report

Land capability (nonirrigated): 3e
Hydrologic Soil Group: D

Typical profile

0 to 7 inches: Gravelly silt loam
7 to 18 inches: Gravelly silt loam
18 to 60 inches: Channery silt loam

Minor Components

Bath

Percent of map unit: 5 percent

Erie

Percent of map unit: 5 percent

Swartswood

Percent of map unit: 5 percent

Lordstown

Percent of map unit: 5 percent

Wurtsboro

Percent of map unit: 5 percent

Soil Information for All Uses

Soil Properties and Qualities

The Soil Properties and Qualities section includes various soil properties and qualities displayed as thematic maps with a summary table for the soil map units in the selected area of interest. A single value or rating for each map unit is generated by aggregating the interpretive ratings of individual map unit components. This aggregation process is defined for each property or quality.

Soil Qualities and Features

Soil qualities are behavior and performance attributes that are not directly measured, but are inferred from observations of dynamic conditions and from soil properties. Example soil qualities include natural drainage, and frost action. Soil features are attributes that are not directly part of the soil. Example soil features include slope and depth to restrictive layer. These features can greatly impact the use and management of the soil.

Hydrologic Soil Group

Hydrologic soil groups are based on estimates of runoff potential. Soils are assigned to one of four groups according to the rate of water infiltration when the soils are not protected by vegetation, are thoroughly wet, and receive precipitation from long-duration storms.

The soils in the United States are assigned to four groups (A, B, C, and D) and three dual classes (A/D, B/D, and C/D). The groups are defined as follows:

Group A. Soils having a high infiltration rate (low runoff potential) when thoroughly wet. These consist mainly of deep, well drained to excessively drained sands or gravelly sands. These soils have a high rate of water transmission.

Group B. Soils having a moderate infiltration rate when thoroughly wet. These consist chiefly of moderately deep or deep, moderately well drained or well drained soils that have moderately fine texture to moderately coarse texture. These soils have a moderate rate of water transmission.

Custom Soil Resource Report

Group C. Soils having a slow infiltration rate when thoroughly wet. These consist chiefly of soils having a layer that impedes the downward movement of water or soils of moderately fine texture or fine texture. These soils have a slow rate of water transmission.

Group D. Soils having a very slow infiltration rate (high runoff potential) when thoroughly wet. These consist chiefly of clays that have a high shrink-swell potential, soils that have a high water table, soils that have a claypan or clay layer at or near the surface, and soils that are shallow over nearly impervious material. These soils have a very slow rate of water transmission.

If a soil is assigned to a dual hydrologic group (A/D, B/D, or C/D), the first letter is for drained areas and the second is for undrained areas. Only the soils that in their natural condition are in group D are assigned to dual classes.

Custom Soil Resource Report Map—Hydrologic Soil Group



Map Scale: 1:2,690 if printed on A portrait (8.5" x 11") sheet.

0 35 70 140 210 Meters

0 100 200 400 600 Feet

Map projection: Web Mercator Corner coordinates: WGS84 Edge tics: UTM Zone 18N WGS84

MAP INFORMATION

MAP LEGEND

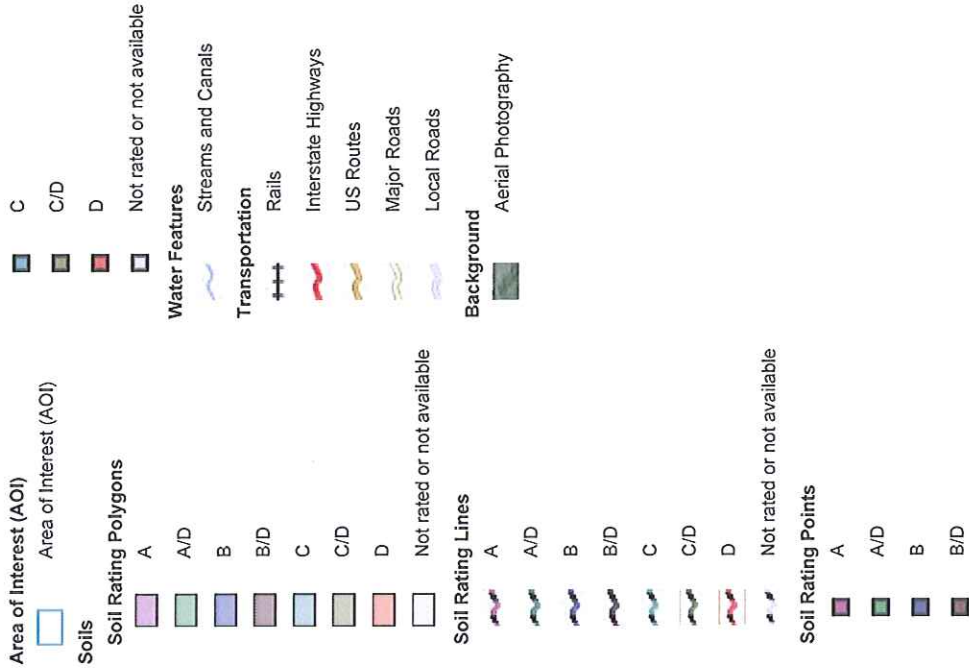

The soil surveys that comprise your AOI were mapped at 1:15,800.

Warning: Soil Map may not be valid at this scale.

Enlargement of maps beyond the scale of mapping can cause misunderstanding of the detail of mapping and accuracy of soil line placement. The maps do not show the small areas of contrasting soils that could have been shown at a more detailed scale.

Please rely on the bar scale on each map sheet for map measurements.

Source of Map: Natural Resources Conservation Service
 Web Soil Survey URL: <http://websoilsurvey.nrcs.usda.gov>
 Coordinate System: Web Mercator (EPSG:3857)

Maps from the Web Soil Survey are based on the Web Mercator projection, which preserves direction and shape but distorts distance and area. A projection that preserves area, such as the Albers equal-area conic projection, should be used if more accurate calculations of distance or area are required.

This product is generated from the USDA-NRCS certified data as of the version date(s) listed below.

Soil Survey Area: Orange County, New York
 Survey Area Data: Version 13, Sep 21, 2012

Soil map units are labeled (as space allows) for map scales 1:50,000 or larger.

Date(s) aerial images were photographed: Mar 26, 2011—Apr 16, 2012

The orthophoto or other base map on which the soil lines were compiled and digitized probably differs from the background imagery displayed on these maps. As a result, some minor shifting of map-unit boundaries may be evident.

Table—Hydrologic Soil Group

Hydrologic Soil Group— Summary by Map Unit — Orange County, New York (NY071)				
Map unit symbol	Map unit name	Rating	Acres in AOI	Percent of AOI
ErA	Erie gravelly silt loam, 0 to 3 percent slopes	D	0.8	6.2%
MdB	Mardin gravelly silt loam, 3 to 8 percent slopes	D	11.5	93.3%
MdC	Mardin gravelly silt loam, 8 to 15 percent slopes	D	0.1	0.5%
Totals for Area of Interest			12.4	100.0%

Rating Options—Hydrologic Soil Group

Aggregation Method: Dominant Condition

Component Percent Cutoff: None Specified

Tie-break Rule: Higher

References

- American Association of State Highway and Transportation Officials (AASHTO). 2004. Standard specifications for transportation materials and methods of sampling and testing. 24th edition.
- American Society for Testing and Materials (ASTM). 2005. Standard classification of soils for engineering purposes. ASTM Standard D2487-00.
- Cowardin, L.M., V. Carter, F.C. Golet, and E.T. LaRoe. 1979. Classification of wetlands and deep-water habitats of the United States. U.S. Fish and Wildlife Service FWS/OBS-79/31.
- Federal Register. July 13, 1994. Changes in hydric soils of the United States.
- Federal Register. September 18, 2002. Hydric soils of the United States.
- Hurt, G.W., and L.M. Vasilas, editors. Version 6.0, 2006. Field indicators of hydric soils in the United States.
- National Research Council. 1995. Wetlands: Characteristics and boundaries.
- Soil Survey Division Staff. 1993. Soil survey manual. Soil Conservation Service. U.S. Department of Agriculture Handbook 18. <http://soils.usda.gov/>
- Soil Survey Staff. 1999. Soil taxonomy: A basic system of soil classification for making and interpreting soil surveys. 2nd edition. Natural Resources Conservation Service, U.S. Department of Agriculture Handbook 436. <http://soils.usda.gov/>
- Soil Survey Staff. 2006. Keys to soil taxonomy. 10th edition. U.S. Department of Agriculture, Natural Resources Conservation Service. <http://soils.usda.gov/>
- Tiner, R.W., Jr. 1985. Wetlands of Delaware. U.S. Fish and Wildlife Service and Delaware Department of Natural Resources and Environmental Control, Wetlands Section.
- United States Army Corps of Engineers, Environmental Laboratory. 1987. Corps of Engineers wetlands delineation manual. Waterways Experiment Station Technical Report Y-87-1.
- United States Department of Agriculture, Natural Resources Conservation Service. National forestry manual. <http://soils.usda.gov/>
- United States Department of Agriculture, Natural Resources Conservation Service. National range and pasture handbook. <http://www.glti.nrcs.usda.gov/>
- United States Department of Agriculture, Natural Resources Conservation Service. National soil survey handbook, title 430-VI. <http://soils.usda.gov/>
- United States Department of Agriculture, Natural Resources Conservation Service. 2006. Land resource regions and major land resource areas of the United States, the Caribbean, and the Pacific Basin. U.S. Department of Agriculture Handbook 296. <http://soils.usda.gov/>

Custom Soil Resource Report

United States Department of Agriculture, Soil Conservation Service. 1961. Land capability classification. U.S. Department of Agriculture Handbook 210.

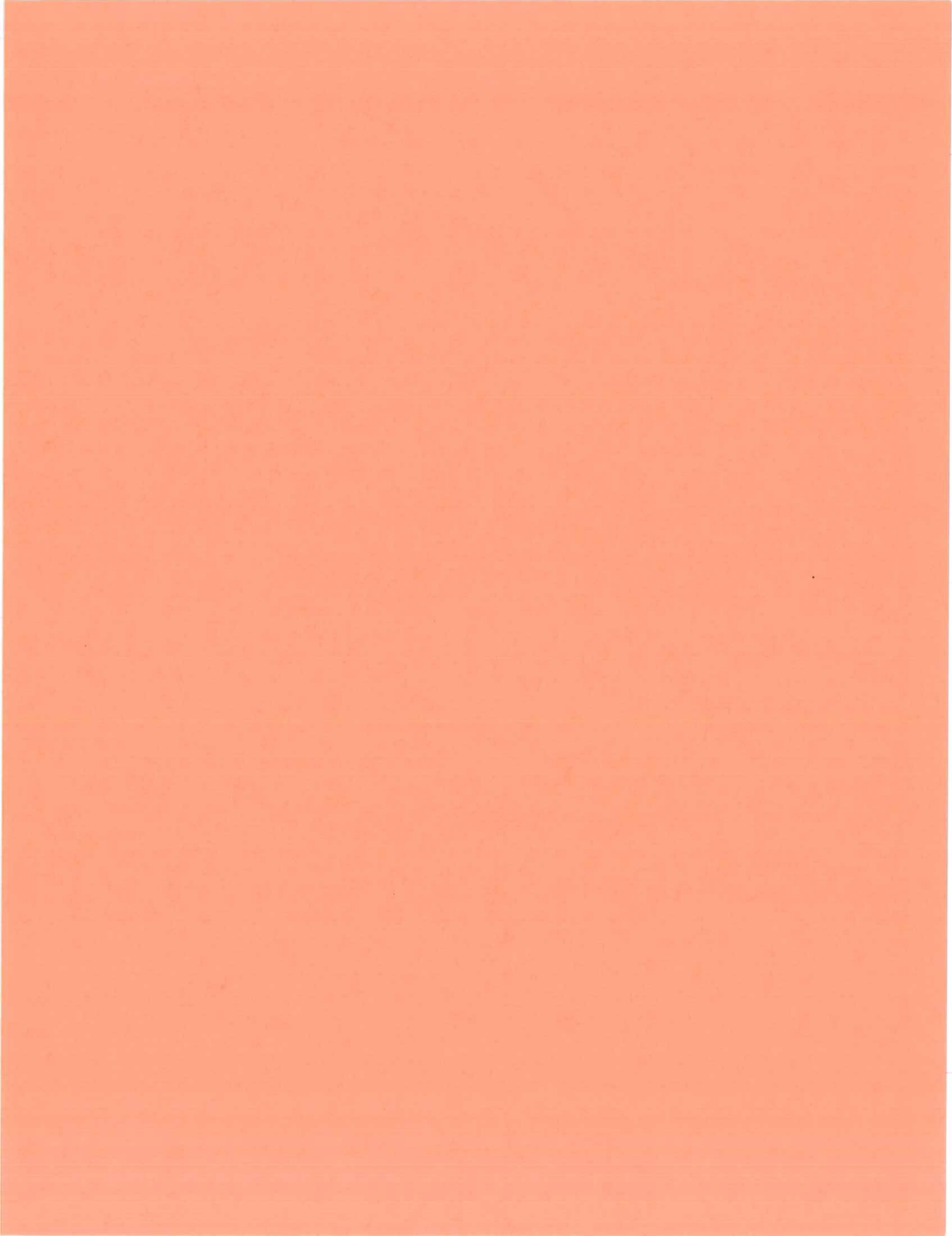

APPENDIX B

PRE/POST-DEVELOPMENT WATERSHED MODELS

Scenario: Pre-Dev 1-Year

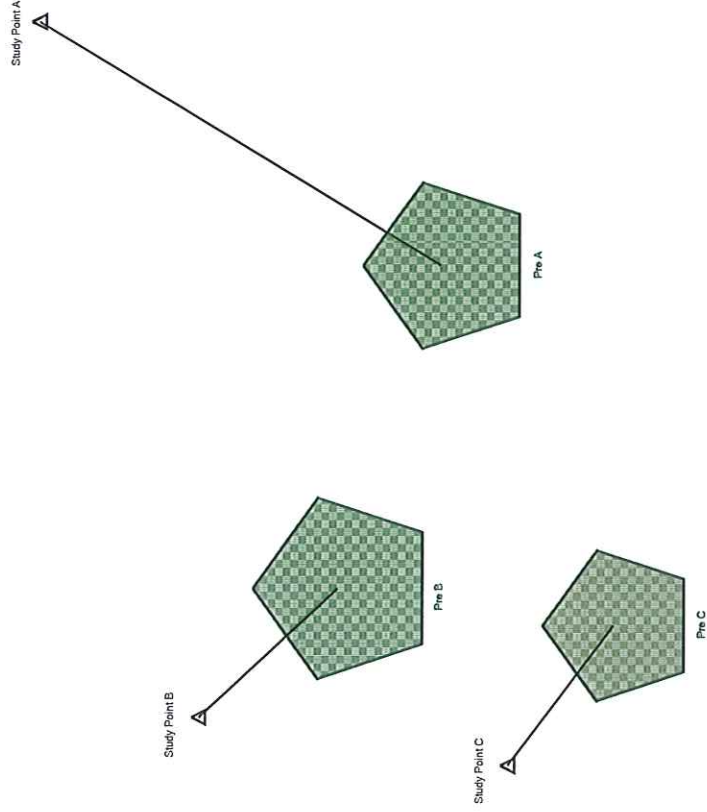

Scenario: Post-Dev 1-Year

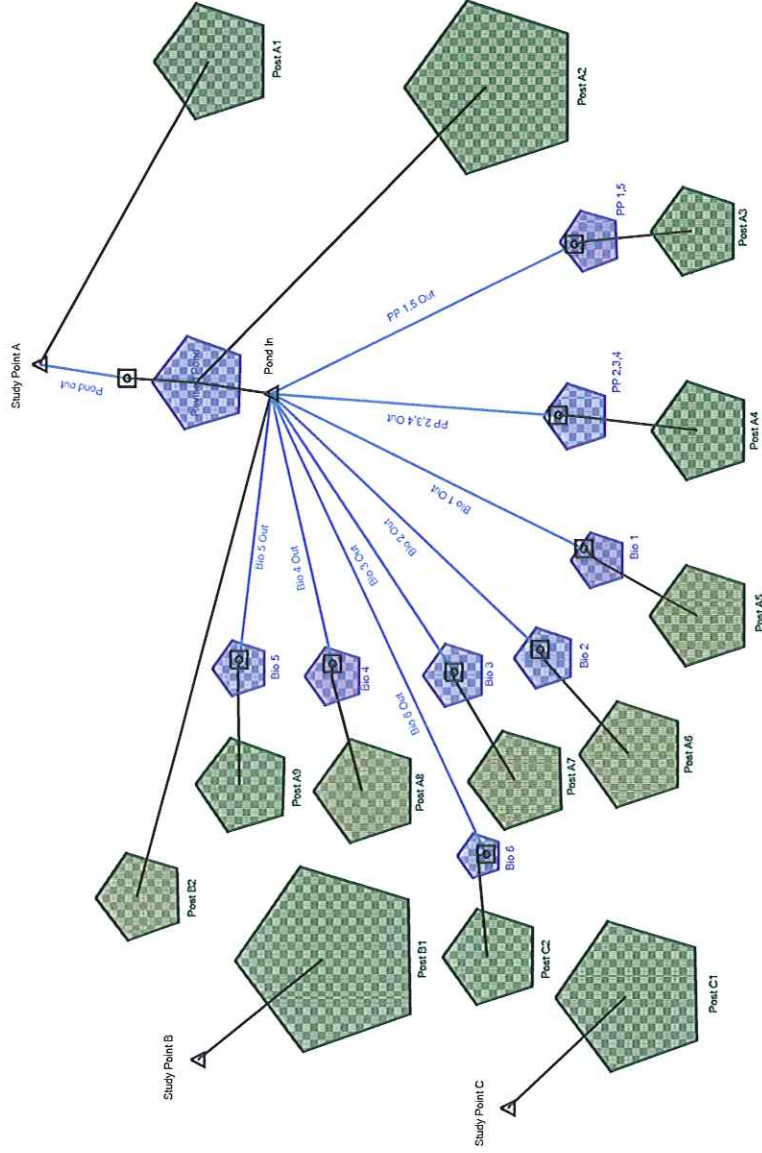

Project Summary

Title CRH Realty VIII,
LLC/Britain Plaza
Engineer Eric Rogge, PE
Company Lane & Tully
Date 2/11/2014

Notes Pre-Development Conditions vs. Post-Development Conditions
Includes lot 97 - 3 - 1, Britain Plaza development

Table of Contents

Orange County	Master Network Summary	2
	Time-Depth Curve, 100 years	6
	Time-Depth Curve, 10 years	8
	Time-Depth Curve, 1 years	10
Post A1	Time of Concentration Calculations, 1 years	12
Post A2	Time of Concentration Calculations, 1 years	14
Post A3	Time of Concentration Calculations, 1 years	16
Post A4	Time of Concentration Calculations, 1 years	18
Post A5	Time of Concentration Calculations, 1 years	20
Post A6	Time of Concentration Calculations, 1 years	22
Post A7	Time of Concentration Calculations, 1 years	24
Post A8	Time of Concentration Calculations, 1 years	26
Post A9	Time of Concentration Calculations, 1 years	28
Post B1	Time of Concentration Calculations, 1 years	30
Post B2	Time of Concentration Calculations, 1 years	32
Post C1	Time of Concentration Calculations, 1 years	34
Post C2	Time of Concentration Calculations, 1 years	36
Pre A	Time of Concentration Calculations, 1 years	38
Pre B	Time of Concentration Calculations, 1 years	40
Pre C	Time of Concentration Calculations, 1 years	42
Post A1	Time of Concentration Calculations, 1 years	42

Table of Contents		
Post A2	Runoff CN-Area, 1 years	44
Post A3	Runoff CN-Area, 1 years	45
Post A4	Runoff CN-Area, 1 years	46
Post A5	Runoff CN-Area, 1 years	47
Post A6	Runoff CN-Area, 1 years	48
Post A7	Runoff CN-Area, 1 years	49
Post A8	Runoff CN-Area, 1 years	50
Post A9	Runoff CN-Area, 1 years	51
Post B1	Runoff CN-Area, 1 years	52
Post B2	Runoff CN-Area, 1 years	53
Post C1	Runoff CN-Area, 1 years	54
Post C2	Runoff CN-Area, 1 years	55
Pre A	Runoff CN-Area, 1 years	56
Pre B	Runoff CN-Area, 1 years	57
Pre C	Runoff CN-Area, 1 years	58
Post A1	Runoff CN-Area, 1 years	59
	Unit Hydrograph Summary, 1 years	60
	Unit Hydrograph Summary, 10 years	61
	Unit Hydrograph Summary, 100 years	62
Post A2	Unit Hydrograph Summary, 1 years	63
	Unit Hydrograph Summary, 10 years	64

Table of Contents		
Post A3	Unit Hydrograph Summary, 100 years	65
	Unit Hydrograph Summary, 1 years	66
	Unit Hydrograph Summary, 10 years	67
	Unit Hydrograph Summary, 100 years	68
Post A4	Unit Hydrograph Summary, 1 years	69
	Unit Hydrograph Summary, 10 years	70
	Unit Hydrograph Summary, 100 years	71
Post A5	Unit Hydrograph Summary, 1 years	72
	Unit Hydrograph Summary, 10 years	73
	Unit Hydrograph Summary, 100 years	74
Post A6	Unit Hydrograph Summary, 1 years	75
	Unit Hydrograph Summary, 10 years	76
	Unit Hydrograph Summary, 100 years	77
Post A7	Unit Hydrograph Summary, 1 years	78
	Unit Hydrograph Summary, 10 years	79
	Unit Hydrograph Summary, 100 years	80
Post A8	Unit Hydrograph Summary, 1 years	81
	Unit Hydrograph Summary, 10 years	82
	Unit Hydrograph Summary, 100 years	83
Post A9	Unit Hydrograph Summary, 1 years	84
	Unit Hydrograph Summary, 10 years	85
	Unit Hydrograph Summary, 100 years	86
Post B1	Unit Hydrograph Summary, 1 years	87
	Unit Hydrograph Summary, 10 years	88
	Unit Hydrograph Summary, 100 years	89
Post B2	Unit Hydrograph Summary, 1 years	90
	Unit Hydrograph Summary, 10 years	91
	Unit Hydrograph Summary, 100 years	92
Post C1	Unit Hydrograph Summary, 100 years	

Table of Contents

Post C2	Unit Hydrograph Summary, 1 years	93
	Unit Hydrograph Summary, 10 years	94
	Unit Hydrograph Summary, 100 years	95
	Unit Hydrograph Summary, 1 years	96
	Unit Hydrograph Summary, 10 years	97
	Unit Hydrograph Summary, 100 years	98
Pre A	Unit Hydrograph Summary, 1 years	99
	Unit Hydrograph Summary, 10 years	100
	Unit Hydrograph Summary, 100 years	101
Pre B	Unit Hydrograph Summary, 1 years	102
	Unit Hydrograph Summary, 10 years	103
	Unit Hydrograph Summary, 100 years	104
Pre C	Unit Hydrograph Summary, 1 years	105
	Unit Hydrograph Summary, 10 years	106
	Unit Hydrograph Summary, 100 years	107
Bio 1	Elevation-Area Volume Curve, 1 years	108
Bio 2	Elevation-Area Volume Curve, 1 years	109
Bio 3	Elevation-Area Volume Curve, 1 years	110
Bio 4	Elevation-Area Volume Curve, 1 years	111
Bio 5	Elevation-Area Volume Curve, 1 years	112
Bio 6	Elevation-Area Volume Curve, 1 years	113
PP 1,5	Elevation-Area Volume Curve, 1 years	114
PP 2,3,4	Elevation-Area Volume Curve, 1 years	115
Revised Pond	Elevation-Area Volume Curve, 1 years	116
Bio 1	Elevation-Area Volume Curve, 1 years	

Table of Contents

Bio 2	Outlet Input Data, 1 years	117
	Individual Outlet Curves, 1 years	121
	Composite Rating Curve, 1 years	124
	Outlet Input Data, 1 years	125
	Individual Outlet Curves, 1 years	129
	Composite Rating Curve, 1 years	132
Bio 3	Outlet Input Data, 1 years	133
	Individual Outlet Curves, 1 years	137
	Composite Rating Curve, 1 years	140
Bio 4	Outlet Input Data, 1 years	141
	Individual Outlet Curves, 1 years	145
	Composite Rating Curve, 1 years	148
Bio 5	Outlet Input Data, 1 years	149
	Individual Outlet Curves, 1 years	153
	Composite Rating Curve, 1 years	156
Bio 6	Outlet Input Data, 1 years	157
	Individual Outlet Curves, 1 years	161
	Composite Rating Curve, 1 years	164
Pond	Outlet Input Data, 1 years	165
	Individual Outlet Curves, 1 years	169
	Composite Rating Curve, 1 years	177
PP 1,5	Outlet Input Data, 1 years	179
	Individual Outlet Curves, 1 years	183
	Composite Rating Curve, 1 years	186
PP 2,3,4	Outlet Input Data, 1 years	187
	Individual Outlet Curves, 1 years	191
	Composite Rating Curve, 1 years	194
Bio 1	Elevation-Volume-Flow Table (Pond), 1 years	195
Bio 2	Elevation-Volume-Flow Table (Pond), 1 years	

Table of Contents

Bio 3	Elevation-Volume-Flow Table (Pond), 1 years	196
Bio 4	Elevation-Volume-Flow Table (Pond), 1 years	197
Bio 5	Elevation-Volume-Flow Table (Pond), 1 years	198
Bio 6	Elevation-Volume-Flow Table (Pond), 1 years	199
PP 1,5	Elevation-Volume-Flow Table (Pond), 1 years	200
PP 2,3,4	Elevation-Volume-Flow Table (Pond), 1 years	201
Revised Pond	Elevation-Volume-Flow Table (Pond), 1 years	202
	Elevation-Volume-Flow Table (Pond), 1 years	203

Subsection: Master Network Summary

Catchments Summary

Label	Scenario	Return Event (Years)	Hydrograph Volume (ft ³)	Time to Peak (hours)	Peak Flow (ft ³ /s)
Pre A	Pre-Dev 1-Year	1	37,498	12.350	6.94
Pre A	Pre-Dev 10-Year	10	95,605	12.300	17.48
Pre A	Pre-Dev 100-Year	100	155,028	12.300	27.85
Pre B	Pre-Dev 1-Year	1	4,074	12.200	0.93
Pre B	Pre-Dev 10-Year	10	10,827	12.200	2.47
Pre B	Pre-Dev 100-Year	100	17,932	12.200	3.99
Pre C	Pre-Dev 1-Year	1	9,480	12.250	1.96
Pre C	Pre-Dev 10-Year	10	23,675	12.250	4.81
Pre C	Pre-Dev 100-Year	100	38,092	12.250	7.58
Post A2	Post-Dev 1-Year	1	23,633	12.100	6.10
Post A2	Post-Dev 10-Year	10	51,352	12.100	12.71
Post A2	Post-Dev 100-Year	100	78,435	12.100	18.96
Post B1	Post-Dev 1-Year	1	858	12.150	0.22
Post B1	Post-Dev 10-Year	10	2,435	12.150	0.62
Post B1	Post-Dev 100-Year	100	4,110	12.150	1.03
Post C1	Post-Dev 1-Year	1	1,142	12.250	0.24
Post C1	Post-Dev 10-Year	10	3,242	12.250	0.68
Post C1	Post-Dev 100-Year	100	5,473	12.250	1.13
Post A1	Post-Dev 1-Year	1	3,102	12.100	0.88
Post A1	Post-Dev 10-Year	10	8,799	12.100	2.48
Post A1	Post-Dev 100-Year	100	14,850	12.100	4.09
Post A3	Post-Dev 1-Year	1	4,535	12.100	1.20
Post A3	Post-Dev 10-Year	10	9,502	12.100	2.36
Post A3	Post-Dev 100-Year	100	14,209	12.100	3.47
Post A4	Post-Dev 1-Year	1	4,243	12.100	1.20
Post A4	Post-Dev 10-Year	10	10,590	12.100	2.90
Post A4	Post-Dev 100-Year	100	17,036	12.100	4.54
Post A5	Post-Dev 1-Year	1	4,785	12.150	1.19
Post A5	Post-Dev 10-Year	10	10,602	12.150	2.53
Post A5	Post-Dev 100-Year	100	16,311	12.150	3.79
Post A6	Post-Dev 1-Year	1	2,212	12.150	0.56
Post A6	Post-Dev 10-Year	10	4,807	12.150	1.15
Post A6	Post-Dev 100-Year	100	7,342	12.150	1.72
Post A7	Post-Dev 1-Year	1	820	12.100	0.22
Post A7	Post-Dev 10-Year	10	2,089	12.100	0.56
Post A7	Post-Dev 100-Year	100	3,386	12.100	0.89
Post A8	Post-Dev 1-Year	1	3,161	12.100	0.84
Post A8	Post-Dev 10-Year	10	6,889	12.100	1.75
Post A8	Post-Dev 100-Year	100	10,492	12.100	2.60
Post A9	Post-Dev 1-Year	1	5,285	12.100	1.41
Post A9	Post-Dev 10-Year	10	11,046	12.100	2.80
Post A9	Post-Dev 100-Year	100	16,534	12.100	4.13
Post B2	Post-Dev 1-Year	1	2,198	12.100	0.60
Post B2	Post-Dev 10-Year	10	4,969	12.100	1.26
Post B2	Post-Dev 100-Year	100	7,491	12.100	1.89
Post C2	Post-Dev 1-Year	1	9,422	12.100	2.53
Post C2	Post-Dev 10-Year	10	20,472	12.100	5.24
Post C2	Post-Dev 100-Year	100	31,269	12.100	7.81

Node Summary

model3.ppc

Bentley Systems, Inc. Heated Methods Solution Center

Bentley PondPack V8i
[08.11.01.59]

Subsection: Master Network Summary

Node Summary

Label	Scenario	Return Event (years)	Hydrograph Volume (ft ³)	Time to Peak (hours)	Peak Flow (ft ³ /s)
Study Point A	Post-Dev 1-Year	1	30,506	12,100	1.30
Study Point A	Pre-Dev 1-Year	1	37,498	12,350	6.94
Study Point A	Post-Dev 10-Year	10	96,787	12,300	16.64
Study Point A	Pre-Dev 10-Year	10	95,605	12,300	17.48
Study Point A	Post-Dev 100-Year	100	170,279	12,250	27.84
Study Point A	Pre-Dev 100-Year	100	155,028	12,300	27.85
Study Point B	Post-Dev 1-Year	1	858	12,150	0.22
Study Point B	Pre-Dev 1-Year	1	4,074	12,200	0.93
Study Point B	Post-Dev 10-Year	10	2,493	12,150	0.62
Study Point B	Pre-Dev 10-Year	10	10,827	12,200	2.47
Study Point B	Post-Dev 100-Year	100	4,110	12,150	1.03
Study Point B	Pre-Dev 100-Year	100	17,832	12,200	3.99
Study Point C	Post-Dev 1-Year	1	1,142	12,250	0.24
Study Point C	Pre-Dev 1-Year	1	9,480	12,250	1.96
Study Point C	Post-Dev 10-Year	10	3,242	12,250	0.68
Study Point C	Pre-Dev 10-Year	10	23,675	12,250	4.81
Study Point C	Post-Dev 100-Year	100	5,473	12,250	1.13
Study Point C	Pre-Dev 100-Year	100	38,092	12,250	7.58

Pond Summary

Label	Scenario	Return Event (years)	Hydrograph Volume (ft ³)	Time to Peak (hours)	Peak Flow (ft ³ /s)	Maximum Water Surface Elevation (ft)	Maximum Pond Storage (ft ³)
PP 1.5 (IN)	Post-Dev 1-Year	1	4,635	12,100	1.20	(N/A)	(N/A)
PP 1.5 (OUT)	Post-Dev 1-Year	1	952	13,600	0.07	350.23	2,968
PP 1.5 (IN)	Post-Dev 10-Year	10	9,502	12,100	2.36	(N/A)	(N/A)
PP 1.5 (OUT)	Post-Dev 10-Year	10	5,498	12,400	0.73	351.14	4,749
PP 1.5 (IN)	Post-Dev 100-Year	100	14,209	12,100	3.47	(N/A)	(N/A)
PP 1.5 (OUT)	Post-Dev 100-Year	100	9,987	12,400	1.09	351.98	6,477
PP 2.3,4 (IN)	Post-Dev 1-Year	1	4,243	12,100	1.20	(N/A)	(N/A)
PP 2.3,4 (OUT)	Post-Dev 1-Year	1	0	0,000	0.00	349.27	2,770
PP 2.3,4 (IN)	Post-Dev 10-Year	10	10,590	12,100	2.90	(N/A)	(N/A)
PP 2.3,4 (OUT)	Post-Dev 10-Year	10	2,705	13,900	0.15	350.21	6,681
PP 2.3,4 (IN)	Post-Dev 100-Year	100	17,036	12,100	4.54	(N/A)	(N/A)
PP 2.3,4 (OUT)	Post-Dev 100-Year	100	8,678	12,600	0.65	350.87	9,402
Blo 1 (IN)	Post-Dev 1-Year	1	4,785	12,150	1.19	(N/A)	(N/A)
Blo 1 (OUT)	Post-Dev 1-Year	1	2,367	14,050	0.09	352.50	3,126

Subsection: Master Network Summary

Pond Summary

Label	Scenario	Return Event (years)	Hydrograph Volume (ft ³)	Time to Peak (hours)	Peak Flow (ft ³ /s)	Maximum Water Surface Elevation (ft)	Maximum Pond Storage (ft ³)
Blo 1 (IN)	Post-Dev 10-Year	10	10,602	12,150	2.53	(N/A)	(N/A)
Blo 1 (OUT)	Post-Dev 10-Year	10	7,660	12,200	2.36	352.62	3,494
Blo 1 (IN)	Post-Dev 100-Year	100	16,311	12,150	3.79	(N/A)	(N/A)
Blo 1 (OUT)	Post-Dev 100-Year	100	13,201	12,200	3.60	352.68	3,701
Blo 2 (IN)	Post-Dev 1-Year	1	2,212	12,150	0.56	(N/A)	(N/A)
Blo 2 (OUT)	Post-Dev 1-Year	1	2,084	12,300	0.43	354.77	818
Blo 2 (IN)	Post-Dev 10-Year	10	4,807	12,150	1.15	(N/A)	(N/A)
Blo 2 (OUT)	Post-Dev 10-Year	10	4,669	12,150	1.16	354.80	850
Blo 2 (IN)	Post-Dev 100-Year	100	7,342	12,100	1.72	(N/A)	(N/A)
Blo 2 (OUT)	Post-Dev 100-Year	100	7,030	12,150	1.73	354.83	875
Blo 3 (IN)	Post-Dev 1-Year	1	820	12,100	0.22	(N/A)	(N/A)
Blo 3 (OUT)	Post-Dev 1-Year	1	816	12,000	0.05	353.75	256
Blo 3 (IN)	Post-Dev 10-Year	10	2,089	12,100	0.56	(N/A)	(N/A)
Blo 3 (OUT)	Post-Dev 10-Year	10	2,078	11,650	0.05	355.43	895
Blo 3 (IN)	Post-Dev 100-Year	100	3,386	12,100	0.89	(N/A)	(N/A)
Blo 3 (OUT)	Post-Dev 100-Year	100	3,363	12,200	0.63	355.54	1,030
Blo 4 (IN)	Post-Dev 1-Year	1	3,161	12,100	0.84	(N/A)	(N/A)
Blo 4 (OUT)	Post-Dev 1-Year	1	3,127	12,250	0.46	354.53	1,448
Blo 4 (IN)	Post-Dev 10-Year	10	6,869	12,100	1.75	(N/A)	(N/A)
Blo 4 (OUT)	Post-Dev 10-Year	10	6,373	12,150	1.68	354.62	1,182
Blo 4 (IN)	Post-Dev 100-Year	100	10,492	12,100	2.60	(N/A)	(N/A)
Blo 4 (OUT)	Post-Dev 100-Year	100	10,492	12,100	2.60	354.68	1,279
Blo 5 (IN)	Post-Dev 1-Year	1	5,285	12,100	1.41	(N/A)	(N/A)
Blo 5 (OUT)	Post-Dev 1-Year	1	4,936	12,100	1.35	353.92	1,171
Blo 5 (IN)	Post-Dev 10-Year	10	11,046	12,100	2.80	(N/A)	(N/A)
Blo 5 (OUT)	Post-Dev 10-Year	10	10,197	12,100	2.74	354.02	1,335

Subsection: Master Network Summary

Pond Summary

Label	Scenario	Return Event (years)	Hydrograph Volume (ft ³)	Time to Peak (hours)	Peak Flow (ft ³ /s)	Maximum Water Surface Elevation (ft)	Maximum Pond Storage (ft ³)
Blo 5 (IN)	Post-Dev 100-Year	100	16,634	12.100	4.13	(N/A)	(N/A)
Blo 5 (OUT)	Post-Dev 100-Year	100	15,616	12.100	4.04	354.11	1,504
Revised Pond (IN)	Post-Dev 1-Year	1	48,454	12.100	10.71	(N/A)	(N/A)
Revised Pond (OUT)	Post-Dev 1-Year	1	27,404	15.850	0.61	344.08	39,419
Revised Pond (IN)	Post-Dev 10-Year	10	114,597	12.100	26.89	(N/A)	(N/A)
Revised Pond (OUT)	Post-Dev 10-Year	10	87,988	12.300	15.48	345.10	52,003
Revised Pond (IN)	Post-Dev 100-Year	100	183,495	12.100	41.08	(N/A)	(N/A)
Revised Pond (OUT)	Post-Dev 100-Year	100	155,430	12.300	25.94	346.03	65,032
Blo 6 (IN)	Post-Dev 1-Year	1	9,422	12.100	2.53	(N/A)	(N/A)
Blo 6 (OUT)	Post-Dev 1-Year	1	8,243	12.100	2.47	352.11	1,453
Blo 6 (IN)	Post-Dev 10-Year	10	20,472	12.100	5.24	(N/A)	(N/A)
Blo 6 (OUT)	Post-Dev 10-Year	10	19,196	12.100	5.14	352.24	1,667
Blo 6 (IN)	Post-Dev 100-Year	100	31,259	12.100	7.81	(N/A)	(N/A)
Blo 6 (OUT)	Post-Dev 100-Year	100	29,991	12.100	7.67	352.35	1,886

Subsection: Time-Depth Curve
Label: Orange County

Return Event: 100 years
Storm Event: 100-Year

Time-Depth Curve: 100-Year	
Label	100-Year
Start Time	0.000 hours
Increment	0.100 hours
End Time	24.000 hours
Return Event	100 years

CUMULATIVE RAINFALL (in)
Output Time Increment = 0.100 hours
Time on left represents time for first value in each row.

Time (hours)	Depth (in)	Depth (in)	Depth (in)	Depth (in)	Depth (in)	Depth (in)	Depth (in)	Depth (in)	Depth (in)
0.000	0.0	0.0	0.0	0.0	0.0	0.0	0.0	0.0	0.0
0.500	0.0	0.0	0.0	0.0	0.0	0.0	0.0	0.0	0.1
1.000	0.0	0.0	0.0	0.0	0.0	0.0	0.0	0.0	0.1
1.500	0.1	0.1	0.1	0.1	0.1	0.1	0.1	0.1	0.2
2.000	0.2	0.2	0.2	0.2	0.2	0.2	0.2	0.2	0.2
2.500	0.2	0.2	0.2	0.2	0.2	0.2	0.2	0.2	0.2
3.000	0.2	0.2	0.2	0.2	0.2	0.2	0.2	0.2	0.2
3.500	0.2	0.2	0.2	0.2	0.2	0.2	0.2	0.2	0.3
4.000	0.2	0.2	0.2	0.2	0.2	0.2	0.2	0.2	0.3
4.500	0.3	0.3	0.3	0.3	0.3	0.3	0.3	0.3	0.4
5.000	0.4	0.4	0.4	0.4	0.4	0.4	0.4	0.4	0.4
5.500	0.5	0.5	0.5	0.5	0.5	0.5	0.5	0.5	0.5
6.000	0.6	0.6	0.6	0.6	0.6	0.6	0.6	0.6	0.6
6.500	0.6	0.6	0.6	0.6	0.6	0.6	0.6	0.6	0.6
7.000	0.7	0.7	0.7	0.7	0.7	0.7	0.7	0.7	0.7
7.500	0.8	0.8	0.8	0.8	0.8	0.8	0.8	0.8	0.8
8.000	0.9	0.9	0.9	0.9	0.9	0.9	0.9	0.9	0.9
8.500	1.0	1.0	1.0	1.0	1.0	1.0	1.0	1.0	1.0
9.000	1.1	1.1	1.1	1.1	1.1	1.1	1.1	1.1	1.1
9.500	1.2	1.2	1.2	1.2	1.2	1.2	1.2	1.2	1.3
10.000	1.3	1.3	1.3	1.3	1.3	1.3	1.3	1.3	1.4
10.500	1.4	1.4	1.4	1.4	1.4	1.4	1.4	1.4	1.5
11.000	1.5	1.5	1.5	1.5	1.5	1.5	1.5	1.5	1.6
11.500	1.6	1.6	1.6	1.6	1.6	1.6	1.6	1.6	1.7
12.000	1.7	1.7	1.7	1.7	1.7	1.7	1.7	1.7	1.8
12.500	1.8	1.8	1.8	1.8	1.8	1.8	1.8	1.8	1.9
13.000	1.9	1.9	1.9	1.9	1.9	1.9	1.9	1.9	2.0
13.500	2.0	2.0	2.0	2.0	2.0	2.0	2.0	2.0	2.1
14.000	2.1	2.1	2.1	2.1	2.1	2.1	2.1	2.1	2.2
14.500	2.2	2.2	2.2	2.2	2.2	2.2	2.2	2.2	2.3
15.000	2.3	2.3	2.3	2.3	2.3	2.3	2.3	2.3	2.4
15.500	2.4	2.4	2.4	2.4	2.4	2.4	2.4	2.4	2.5
16.000	2.5	2.5	2.5	2.5	2.5	2.5	2.5	2.5	2.6
16.500	2.6	2.6	2.6	2.6	2.6	2.6	2.6	2.6	2.7
17.000	2.7	2.7	2.7	2.7	2.7	2.7	2.7	2.7	2.8
17.500	2.8	2.8	2.8	2.8	2.8	2.8	2.8	2.8	2.9
18.000	2.9	2.9	2.9	2.9	2.9	2.9	2.9	2.9	3.0
18.500	3.0	3.0	3.0	3.0	3.0	3.0	3.0	3.0	3.1
19.000	3.1	3.1	3.1	3.1	3.1	3.1	3.1	3.1	3.2
19.500	3.2	3.2	3.2	3.2	3.2	3.2	3.2	3.2	3.3
20.000	3.3	3.3	3.3	3.3	3.3	3.3	3.3	3.3	3.4
20.500	3.4	3.4	3.4	3.4	3.4	3.4	3.4	3.4	3.5

Subsection: Time-Depth Curve
Label: Orange County

Return Event: 100 years
Storm Event: 100-Year

CUMULATIVE RAINFALL (in)
Output Time Increment = 0.100 hours
Time on left represents time for first value in each row.

Time (hours)	Depth (in)	Depth (in)	Depth (in)	Depth (in)	Depth (in)	Depth (in)
21,000	7.8	7.8	7.8	7.8	7.8	7.8
21,500	7.8	7.8	7.8	7.9	7.9	7.8
22,000	7.8	7.9	7.9	7.9	7.9	7.9
22,500	7.9	7.9	7.9	7.9	8.0	8.0
23,000	8.0	8.0	8.0	8.0	8.0	8.0
23,500	8.0	(N/A)	(N/A)	(N/A)	(N/A)	(N/A)
24,000	8.0	(N/A)	(N/A)	(N/A)	(N/A)	(N/A)

Subsection: Time-Depth Curve
Label: Orange County

Return Event: 10 years
Storm Event: 10-Year

CUMULATIVE RAINFALL (in)
Output Time Increment = 0.100 hours
Time on left represents time for first value in each row.

Time (hours)	Depth (in)	Depth (in)	Depth (in)	Depth (in)	Depth (in)	Depth (in)
0.000	0.0	0.0	0.0	0.0	0.0	0.0
0.500	0.0	0.0	0.0	0.0	0.0	0.0
1.000	0.1	0.1	0.1	0.1	0.1	0.1
1.500	0.1	0.1	0.1	0.1	0.1	0.1
2.000	0.1	0.1	0.1	0.1	0.1	0.1
2.500	0.1	0.1	0.1	0.1	0.1	0.1
3.000	0.2	0.2	0.2	0.2	0.2	0.2
3.500	0.2	0.2	0.2	0.2	0.2	0.2
4.000	0.2	0.2	0.2	0.2	0.2	0.2
4.500	0.3	0.3	0.3	0.3	0.3	0.3
5.000	0.3	0.3	0.3	0.3	0.3	0.3
5.500	0.4	0.4	0.4	0.4	0.4	0.4
6.000	0.4	0.4	0.4	0.4	0.4	0.4
6.500	0.4	0.5	0.5	0.5	0.5	0.5
7.000	0.5	0.5	0.5	0.5	0.5	0.5
7.500	0.6	0.6	0.6	0.6	0.6	0.6
8.000	0.6	0.6	0.6	0.7	0.7	0.7
8.500	0.7	0.7	0.7	0.7	0.7	0.7
9.000	0.8	0.8	0.8	0.8	0.8	0.8
9.500	0.9	0.9	0.9	0.9	0.9	0.9
10.000	1.0	1.0	1.0	1.0	1.0	1.0
10.500	1.1	1.1	1.1	1.1	1.1	1.1
11.000	1.2	1.2	1.2	1.2	1.2	1.2
11.500	1.3	1.3	1.3	1.3	1.3	1.3
12.000	1.4	1.4	1.4	1.4	1.4	1.4
12.500	1.6	1.6	1.6	1.6	1.6	1.6
13.000	1.7	1.7	1.7	1.7	1.7	1.7
13.500	1.9	1.9	1.9	1.9	1.9	1.9
14.000	2.1	2.1	2.1	2.1	2.1	2.1
14.500	2.2	2.2	2.2	2.2	2.2	2.2
15.000	2.3	2.3	2.3	2.3	2.3	2.3
15.500	2.4	2.4	2.4	2.4	2.4	2.4
16.000	2.7	2.7	2.7	2.7	2.7	2.7
16.500	2.9	2.9	2.9	2.9	2.9	2.9
17.000	3.1	3.1	3.1	3.1	3.1	3.1
17.500	3.2	3.2	3.2	3.2	3.2	3.2
18.000	3.3	3.3	3.3	3.3	3.3	3.3
18.500	3.4	3.4	3.4	3.4	3.4	3.4
19.000	3.5	3.5	3.5	3.5	3.5	3.5
19.500	3.6	3.6	3.6	3.6	3.6	3.6
20.000	3.9	3.9	3.9	3.9	3.9	3.9
20.500	4.1	4.1	4.1	4.1	4.1	4.1
21.000	4.2	4.2	4.2	4.2	4.2	4.2
21.500	4.3	4.3	4.3	4.3	4.3	4.3
22.000	4.4	4.4	4.4	4.4	4.4	4.4
22.500	4.5	4.5	4.5	4.5	4.5	4.5
23.000	4.6	4.6	4.6	4.6	4.6	4.6
23.500	4.7	4.7	4.7	4.7	4.7	4.7
24.000	4.8	4.8	4.8	4.8	4.8	4.8
24.500	4.9	4.9	4.9	4.9	4.9	4.9
25.000	5.0	5.0	5.0	5.0	5.0	5.0
25.500	5.1	5.1	5.1	5.1	5.1	5.1
26.000	5.1	5.1	5.1	5.1	5.1	5.1
26.500	5.1	5.1	5.1	5.1	5.1	5.1
27.000	5.2	5.2	5.2	5.2	5.2	5.2
27.500	5.2	5.2	5.2	5.2	5.2	5.2
28.000	5.2	5.2	5.2	5.2	5.2	5.2
28.500	5.2	5.2	5.2	5.2	5.2	5.2
29.000	5.3	5.3	5.3	5.3	5.3	5.3
29.500	5.3	5.3	5.3	5.3	5.3	5.3
30.000	5.3	5.3	5.3	5.3	5.3	5.3

Subsection: Time-Depth Curve
Label: Orange County

Return Event: 10 years
Storm Event: 10-Year

CUMULATIVE RAINFALL (in)
Output Time Increment = 0.100 hours
Time on left represents time for first value in each row.

Time (hours)	Depth (in)	Depth (in)	Depth (in)	Depth (in)	Depth (in)
21,000	5.3	5.3	5.3	5.4	5.4
21,500	5.4	5.4	5.4	5.4	5.4
22,000	5.4	5.4	5.4	5.4	5.4
22,500	5.4	5.4	5.4	5.4	5.4
23,000	5.5	5.5	5.5	5.5	5.5
23,500	5.5	5.5	5.5	5.5	5.5
24,000	5.5	(N/A)	(N/A)	(N/A)	(N/A)

Subsection: Time-Depth Curve
Label: Orange County

Return Event: 1 years
Storm Event: 1-Year

CUMULATIVE RAINFALL (in)
Output Time Increment = 0.100 hours
Time on left represents time for first value in each row.

Time (hours)	Depth (in)	Depth (in)	Depth (in)	Depth (in)	Depth (in)
0.000	0.0	0.0	0.0	0.0	0.0
0.500	0.0	0.0	0.0	0.0	0.0
1.000	0.0	0.0	0.0	0.0	0.0
1.500	0.0	0.0	0.0	0.0	0.0
2.000	0.1	0.1	0.1	0.1	0.1
2.500	0.1	0.1	0.1	0.1	0.1
3.000	0.1	0.1	0.1	0.1	0.1
3.500	0.1	0.1	0.1	0.1	0.1
4.000	0.1	0.1	0.1	0.1	0.1
4.500	0.1	0.1	0.1	0.1	0.1
5.000	0.1	0.1	0.1	0.1	0.1
5.500	0.2	0.2	0.2	0.2	0.2
6.000	0.2	0.2	0.2	0.2	0.2
6.500	0.2	0.2	0.2	0.2	0.2
7.000	0.2	0.2	0.2	0.2	0.2
7.500	0.3	0.3	0.3	0.3	0.3
8.000	0.3	0.3	0.3	0.3	0.3
8.500	0.4	0.4	0.4	0.4	0.4
9.000	0.4	0.4	0.4	0.4	0.4
9.500	0.5	0.5	0.5	0.5	0.5
10.000	0.5	0.5	0.5	0.5	0.5
10.500	0.6	0.6	0.6	0.6	0.6
11.000	0.6	0.6	0.6	0.6	0.6
11.500	0.7	0.7	0.7	0.7	0.7
12.000	0.7	0.7	0.7	0.7	0.7
12.500	0.8	0.8	0.8	0.8	0.8
13.000	0.9	0.9	0.9	0.9	0.9
13.500	1.0	1.0	1.0	1.0	1.0
14.000	1.1	1.1	1.1	1.1	1.1
14.500	1.2	1.2	1.2	1.2	1.2
15.000	1.3	1.3	1.3	1.3	1.3
15.500	1.4	1.4	1.4	1.4	1.4
16.000	1.5	1.5	1.5	1.5	1.5
16.500	1.6	1.6	1.6	1.6	1.6
17.000	1.7	1.7	1.7	1.7	1.7
17.500	1.8	1.8	1.8	1.8	1.8
18.000	1.9	1.9	1.9	1.9	1.9
18.500	2.0	2.0	2.0	2.0	2.0
19.000	2.1	2.1	2.1	2.1	2.1
19.500	2.2	2.2	2.2	2.2	2.2
20.000	2.3	2.3	2.3	2.3	2.3
20.500	2.4	2.4	2.4	2.4	2.4

Subsection: Time-Depth Curve
Label: Orange County

Return Event: 1 years
Storm Event: 1-Year

CUMULATIVE RAINFALL (in)
Output Time Increment = 0.100 hours
Time on left represents time for first value in each row.

Time (hours)	Depth (in)	Depth (in)	Depth (in)	Depth (in)	Depth (in)	Depth (in)
21,000	2.8	2.8	2.8	2.8	2.8	2.8
21,500	2.8	2.8	2.8	2.8	2.8	2.8
22,000	2.8	2.8	2.8	2.8	2.8	2.8
22,500	2.9	2.9	2.9	2.9	2.9	2.9
23,000	2.9	2.9	2.9	2.9	2.9	2.9
23,500	2.9	2.9	2.9	2.9	2.9	2.9
24,000	2.9	(N/A)	(N/A)	(N/A)	(N/A)	(N/A)

Subsection: Time of Concentration Calculations
Label: Post A1

Return Event: 1 years
Storm Event: 1-Year

Time of Concentration Results
Segment #1: TR-55 Sheet Flow

Hydraulic Length	90.00 ft
Manning's n	0.240
Slope	0.160 ft/ft
2 Year 24-Hour Depth	3.5 in
Average Velocity	0.27 ft/s
Segment Time of Concentration	0.091 hours

Time of Concentration (Composite)	
Time of Concentration (Composite)	0.091 hours

Subsection: Time of Concentration Calculations
Label: Post A1

Return Event: 1 years
Storm Event: 1-Year

==== SCS Channel Flow

$$R = Q_p / W_p$$

$$V = (1.49 * (R^{0.487} * (S^{0.487} * (S^{0.487} - 0.5))) / n$$

(L / V) / 3600
R= Hydraulic radius
A= Flow area, square feet
Wp= Wetted perimeter, feet
V= Velocity, ft/sec
S= Slope, ft/ft
n= Manning's n
Tc= Time of concentration, hours
L= Flow length, feet

Tc =

Where:

model3.ppc
3/5/2014

Bentley PermitPack V8i
[08.11.01.65]
Page 13 of 203

Bentley Systems, Inc. - Harstad Methods Solution Center
27 Simon Company Drive Suite 200 W Watertown, CT
06795 USA +1-203-755-1988

Subsection: Time of Concentration Calculations
Label: Post A2

Return Event: 1 years
Storm Event: 1-Year

Time of Concentration Results

Segment #1: TR-55 Sheet Flow	
Hydraulic Length	75.00 ft
Manning's n	0.240
Slope	0.093 ft/ft
2 Year 24-Hour Depth	3.5 in
Average Velocity	0.21 ft/s
Segment Time of Concentration	0.098 hours
Segment #2: TR-55 Shallow Concentrated Flow	
Hydraulic Length	95.00 ft
Is Paved?	True
Slope	0.010 ft/ft
Average Velocity	2.03 ft/s
Segment Time of Concentration	0.013 hours
Segment #3: TR-55 Channel Flow	
Flow Area	1.8 ft ²
Hydraulic Length	724.00 ft
Manning's n	0.012
Slope	0.010 ft/ft
Wetted Perimeter	4.71 ft
Average Velocity	6.47 ft/s
Segment Time of Concentration	0.031 hours
Time of Concentration (Composite)	
Time of Concentration (Composite)	0.142 hours

model3.ppc
3/5/2014

Bentley Systems, Inc. - Harstad Methods Solution Center
27 Simon Company Drive Suite 200 W Watertown, CT
06795 USA +1-203-755-1988

Bentley PermitPack V8i
[08.11.01.65]
Page 14 of 203

Subsection: Time of Concentration Calculations
 Label: Post A2

Return Event: 1 years
 Storm Event: 1-Year

==== SCS Channel Flow

$R = Qp / Wp$
 $V = (1.49 * (R^{0.486})) / n$
 $(L / V) / 3600$
 $R =$ Hydraulic radius
 $A =$ Flow area, square feet
 $W =$ Wetted Perimeter, feet
 $V =$ Velocity, ft/sec
 $S =$ Slope, ft/ft
 $n =$ Manning's n
 $Tc =$ Time of concentration, hours
 $L =$ Flow length, feet

Where:

==== SCS TR-55 Shallow Concentration Flow

Unpaved surface:
 $V = 16.1345 * (S^{0.5})$
 Paved Surface:
 $V = 20.3282 * (S^{0.5})$
 $(L / V) / 3600$
 $V =$ Velocity, ft/sec
 $S =$ Slope, ft/ft
 $Tc =$ Time of concentration, hours
 $L =$ Flow length, feet

Where:

==== SCS TR-55 Sheet Flow

$(0.007 * ((n * L)^{0.8})) / ((P^{0.5}) * (S^{0.41}))$
 $Tc =$ Time of concentration, hours
 $n =$ Manning's n
 $L =$ Flow length, feet
 $P =$ 24hr Rain depth, inches
 $S =$ Slope, %

Where:

Subsection: Time of Concentration Calculations
 Label: Post A3

Return Event: 1 years
 Storm Event: 1-Year

Time of Concentration Results

Segment #1: TR-55 Sheet Flow	
Hydraulic Length	35.00 ft
Manning's n	0.240
Slope	0.030 ft/ft
2 Year 24-Hour Depth	3.5 in
Average Velocity	0.12 ft/s
Segment Time of Concentration	0.083 hours
Segment #2: TR-55 Sheet Flow	
Hydraulic Length	49.00 ft
Manning's n	0.013
Slope	0.030 ft/ft
2 Year 24 Hour Depth	3.5 in
Average Velocity	1.28 ft/s
Segment Time of Concentration	0.011 hours
Time of Concentration (Composite)	
Time of Concentration (Composite)	0.094 hours

model3.ppc
 3/6/2014

Bentley Systems, Inc. - Harsco Methods Solution Center
 27 Siemon Company Drive Suite 200 W. Watertown, CT
 06795 USA +1-203-755-1996

Bentley PondPack V8i
 [08.11.01.60]
 Page 15 of 203

Bentley Systems, Inc. - Harsco Methods Solution Center
 27 Siemon Company Drive Suite 200 W. Watertown, CT
 06795 USA +1-203-755-1996

Bentley PondPack V8i
 [08.11.01.60]
 Page 16 of 203

Subsection: Time of Concentration Calculations
 Label: Post A3

Return Event: 1 years
 Storm Event: 1-Year

==== SCS Channel Flow

$$T_c = \frac{R \cdot C_p / W_p}{V} = \frac{(L_f / V) \cdot (R^{**}(2/3)) \cdot (S^{**}(0.5))}{n}$$

- Where:
- R= Hydraulic radius
 - A_c= Flow area, square feet
 - W_p= Wetted Perimeter, feet
 - V= Velocity, ft/sec
 - S= Slope, ft/ft
 - n= Manning's n
 - T_c= Time of concentration, hours
 - L_f= Flow length, feet

Subsection: Time of Concentration Calculations
 Label: Post A4

Return Event: 1 years
 Storm Event: 1-Year

Time of Concentration Results

Segment #1: TR-55 Sheet Flow	
Hydraulic Length	47.00 ft
Manning's n	0.240
Slope	0.053 ft/ft
2 Year 24 Hour Depth	3.5 in
Average Velocity	0.16 ft/s
Segment Time of Concentration	0.084 hours
Segment #2: TR-55 Street Flow	
Hydraulic Length	27.00 ft
Manning's n	0.013
Slope	0.008 ft/ft
2 Year 24 Hour Depth	3.5 in
Average Velocity	0.67 ft/s
Segment Time of Concentration	0.011 hours
Time of Concentration (Composite)	
Time of Concentration (Composite)	0.095 hours

Subsection: Time of Concentration Calculations
 Label: Post A3

Return Event: 1 years
 Storm Event: 1-Year

==== SCS Channel Flow

$$T_c = \frac{R \cdot C_p / W_p}{V} = \frac{(L_f / V) \cdot (R^{**}(2/3)) \cdot (S^{**}(0.5))}{n}$$

- Where:
- R= Hydraulic radius
 - A_c= Flow area, square feet
 - W_p= Wetted Perimeter, feet
 - V= Velocity, ft/sec
 - S= Slope, ft/ft
 - n= Manning's n
 - T_c= Time of concentration, hours
 - L_f= Flow length, feet

Subsection: Time of Concentration Calculations
 Label: Post A4

Return Event: 1 years
 Storm Event: 1-Year

==== SCS Channel Flow

$$R = Qs / Wp$$

$$V = (1.49 * (R^{0.486} * (S^{0.486} * (S^{0.045}))) / n$$

(L / V) / 3600
 R= Hydraulic radius
 Qs= Flow, square feet
 Wp= Wetted perimeter, feet
 V= Velocity, ft/sec
 S= Slope, ft/ft
 n= Manning's n
 Tc= Time of concentration, hours
 L= Flow length, feet

Tc =

Where:

Subsection: Time of Concentration Calculations
 Label: Post A5

Return Event: 1 years
 Storm Event: 1-Year

Time of Concentration Results

Segment #1: TR-55 Sheet Flow	75.00 ft
Hydraulic Length	75.00 ft
Manning's n	0.240
Slope	0.020 ft/ft
2 Year 24-Hour Depth	3.5 in
Average Velocity	0.12 ft/s
Segment Time of Concentration	0.181 hours
Segment #2: TR-55 Sheet Flow	25.00 ft
Hydraulic Length	25.00 ft
Manning's n	0.013
Slope	0.040 ft/ft
2 Year 24-Hour Depth	3.5 in
Average Velocity	1.26 ft/s
Segment Time of Concentration	0.006 hours
Segment #3: TR-55 Shallow Concentrated Flow	39.00 ft
Hydraulic Length	39.00 ft
Is Paved?	True
Slope	0.043 ft/ft
Average Velocity	4.22 ft/s
Segment Time of Concentration	0.003 hours
Time of Concentration (Composite)	
Time of Concentration (Composite)	0.189 hours

Subsection: Time of Concentration Calculations
 Label: Post A5

Return Event: 1 years
 Storm Event: 1-Year

==== SCS Channel Flow

Tc = $\frac{R}{V} = \frac{Cp}{Wp} = \frac{(Lf / V) / 3600}{(1.49 * (R^{2/3}) * (S^{1/3})) / n}$

Where:
 R= Hydraulic radius
 Cp= Flow area, square feet
 Wp= Wetted perimeter, feet
 V= Velocity, ft/sec
 S= Slope, ft/ft
 n= Manning's n
 Tc= Time of concentration, hours
 Lf= Flow length, feet

==== SCS TR-55 Shallow Concentration Flow

Unpaved surface:
 $V = 16.1345 * (S^{1/3})$
 Paved Surface:
 $V = 20.3282 * (S^{1/3})$

Where:
 V= Velocity, ft/sec
 S= Slope, ft/ft
 Tc= Time of concentration, hours
 Lf= Flow length, feet

Subsection: Time of Concentration Calculations
 Label: Post A6

Return Event: 1 years
 Storm Event: 1-Year

Time of Concentration Results

Segment #1: TR-55 Sheet Flow	
Hydraulic Length	62.00 ft
Manning's n	0.240
Slope	0.020 ft/ft
2 Year 24-Hour Depth	3.5 in
Average Velocity	0.11 ft/s
Segment Time of Concentration	0.155 hours
Segment #2: TR-55 Sheet Flow	
Hydraulic Length	30.00 ft
Manning's n	0.013
Slope	0.044 ft/ft
2 Year 24-Hour Depth	3.5 in
Average Velocity	1.36 ft/s
Segment Time of Concentration	0.006 hours
Time of Concentration (Composite)	
Time of Concentration (Composite)	0.161 hours

Subsection: Time of Concentration Calculations
 Label: Post A6

Return Event: 1 years
 Storm Event: 1-Year

==== SCS Channel Flow

Tc =
$$R = Qs / Wp$$

$$V = (1.49 * (R^{0.486} * (S^{0.486} * (2/3)) * (S^{0.486} * 0.5))) / n$$

- (Lf / V) / 3600
- R= Hydraulic radius
- A= Flow area, square feet
- Wp= Wetted Perimeter, feet
- V= Velocity ft/sec
- S= Slope, ft/ft
- n= Manning's n
- Tc= Time of concentration, hours
- Lf= Flow length, feet

Where:

Subsection: Time of Concentration Calculations
 Label: Post A7

Return Event: 1 years
 Storm Event: 1-Year

Time of Concentration Results

Segment #1: TR-55 Sheet Flow	
Hydraulic Length	29.00 ft
Manning's n	0.240
Slope	0.010 ft/ft
2 Year 24 Hour Depth	3.5 in
Average Velocity	0.07 ft/s
Segment Time of Concentration	0.111 hours
Segment #2: TR-55 Sheet Flow	
Hydraulic Length	32.00 ft
Manning's n	0.013
Slope	0.042 ft/ft
2 Year 24 Hour Depth	3.5 in
Average Velocity	1.35 ft/s
Segment Time of Concentration	0.007 hours
Time of Concentration (Composite)	
Time of Concentration (Composite)	0.118 hours

Subsection: Time of Concentration Calculations
 Label: Post A7

Return Event: 1 years
 Storm Event: 1-Year

==== SCS Channel Flow

$$T_c = \frac{R_n \cdot C_p / W_p}{(L_f / V) / 3600} = (1.49 \cdot R_n^{0.77} \cdot C_p^{0.017}) \cdot (S^{0.484 - 0.0195 L_f}) / n$$

- R_n = Hydraulic radius
- A_p = Flow area, square feet
- W_p = Wetted perimeter, feet
- V = Velocity, ft/sec
- S_f = Slope, ft/ft
- n = Manning's n
- T_c = Time of concentration, hours
- L_f = Flow length, feet

Where:

Subsection: Time of Concentration Calculations
 Label: Post A8

Return Event: 1 years
 Storm Event: 1-Year

Time of Concentration Results

Segment #1: TR-55 Sheet Flow	
Hydraulic Length	31.00 ft
Manning's n	0.240
Slope	0.012 ft/ft
2 Year 24 Hour Depth	3.5 in
Average Velocity	0.08 ft/s
Segment Time of Concentration	0.109 hours
Segment #2: TR-55 Sheet Flow	
Hydraulic Length	36.00 ft
Manning's n	0.013
Slope	0.042 ft/ft
2 Year 24 Hour Depth	3.5 in
Average Velocity	1.98 ft/s
Segment Time of Concentration	0.007 hours
Time of Concentration (Composite)	
Time of Concentration (Composite)	0.117 hours

Subsection: Time of Concentration Calculations
 Label: Post A8

Return Event: 1 years
 Storm Event: 1-Year

==== SCS Channel Flow

$T_c = \frac{Q_p \cdot W_p}{(L_f / V) / 3600}$
 $V = (1.49 \cdot (R^{2/3}) \cdot (S^{1/2} \cdot 0.5)) / n$

- R= Hydraulic radius
- A_p= Flow area, square feet
- W_p= Wetted perimeter, feet
- V= Velocity, ft/sec
- S= Slope, ft/ft
- n= Manning's n
- T_c= Time of concentration, hours
- L_f= Flow length, feet

Where:

Subsection: Time of Concentration Calculations
 Label: Post A9

Return Event: 1 years
 Storm Event: 1-Year

Time of Concentration Results

Segment #1: TR-55 Sheet Flow	
Hydraulic Length	10.00 ft
Manning's n	0.240
Slope	0.012 ft/ft
2 Year 24-Hour Depth	3.5 in
Average Velocity	0.06 ft/s
Segment Time of Concentration	0.044 hours
Segment #2: TR-55 Sheet Flow	
Hydraulic Length	65.00 ft
Manning's n	0.013
Slope	0.042 ft/ft
2 Year 24 Hour Depth	3.5 in
Average Velocity	1.55 ft/s
Segment Time of Concentration	0.012 hours
Time of Concentration (Composite)	
Time of Concentration (Composite)	0.083 hours

Subsection: Time of Concentration Calculations
 Label: Post A9

Return Event: 1 years
 Storm Event: 1-Year

==== SCS Channel Flow

Tc = $R = Qs / Wp$
 $V = (1.49 * (R^{.67})) * (S^{.485}) / n$

- (L / V) / 3600
- R= Hydraulic radius
- Aq= Flow area, square feet
- Wp= Wetted perimeter, feet
- V= Velocity, ft/sec
- Sf= Slope, ft/ft
- n= Manning's
- Tc= Time of concentration, hours
- L= Flow length, feet

Where:

Subsection: Time of Concentration Calculations
 Label: Post B1

Return Event: 1 Years
 Storm Event: 1-Year

Time of Concentration Results

Segment #1: TR-55 Sheet Flow	
Hydraulic Length	100.00 ft
Manning's n	0.240
Slope	0.036 ft/ft
2 Year 24 Hour Depth	3.5 in
Average Velocity	0.15 ft/s
Segment Time of Concentration	0.180 hours
<hr/>	
Time of Concentration (Composite)	
Time of Concentration (Composite)	0.180 hours

Subsection: Time of Concentration Calculations
 Label: Post B1

Return Event: 1 years
 Storm Event: 1-Year

==== SCS Channel Flow

$$R = Qs / Wp$$

$$V = (1.49 * (R**(2/3))) * (S**(0.5)) / n$$

- (Lf / V) / 3600
- R= hydraulic radius
- Aq= flow area, square feet
- Wp= wetted perimeter, feet
- V= Velocity, ft/sec
- S= Slope, ft/ft
- n= Manning's
- Tc= Time of concentration, hours
- Lf= Flow length, feet

Tc =

Where:

Subsection: Time of Concentration Calculations
 Label: Post B2

Return Event: 1 years
 Storm Event: 1-Year

Time of Concentration Results

Segment #1: TR-55 Sheet Flow	
Hydraulic Length	32.00 ft
Manning's n	0.240
Slope	0.025 ft/ft
2 Year 24-Hour Depth	3.5 in
Average Velocity	0.11 ft/s
Segment Time of Concentration	0.082 hours
Segment #2: TR-55 Shallow Concentrated Flow	
Hydraulic Length	161.00 ft
Is Paved?	True
Slope	0.040 ft/ft
Average Velocity	4.07 ft/s
Segment Time of Concentration	0.011 hours
Segment #3: TR-55 Channel Flow	
Flow Area	1.8 ft ²
Hydraulic Length	275.00 ft
Manning's n	0.012
Slope	0.010 ft/ft
Wetted Perimeter	4.71 ft
Average Velocity	6.54 ft/s
Segment Time of Concentration	0.012 hours
Time of Concentration (Composite)	
Time of Concentration (Composite)	0.105 hours

Subsection: Time of Concentration Calculations
 Label: Post 82

Return Event: 1 Year
 Storm Event: 1-Year

==== SCS Channel Flow

$T_c = \frac{R + C_p \cdot W_p}{V} = (1.49 \cdot C_p^{(2/3)}) \cdot (S^{(1-0.5)}) / n$
 $(L_f / V) / 3600$
 R= Hydraulic radius
 Ap= Flow area, square feet
 Wp= Wetted perimeter, feet
 V= Velocity, ft/sec
 S= Slope, ft/ft
 n= Manning's n
 Tc= Time of concentration, hours
 Lf= Flow length, feet

==== SCS TR-55 Shallow Concentration Flow

Unpaved surface:
 $V = 16.1345 \cdot (S^{(1-0.5)})$
 Paved Surface:
 $V = 20.3282 \cdot (S^{(1-0.5)})$
 $(L_f / V) / 3600$
 V= Velocity, ft/sec
 S= Slope, ft/ft
 Tc= Time of concentration, hours
 Lf= Flow length, feet

==== SCS TR-55 Sheet Flow

$T_c = \frac{(0.007 \cdot ((n \cdot L_f)^{0.6}))}{((P^{(1-0.5)}) \cdot (S^{(1-0.4))))}$
 Tc= Time of concentration, hours
 n= Manning's n
 Lf= Flow length, feet
 P= 24" Rain depth, inches
 S= Slope, %

Subsection: Time of Concentration Calculations
 Label: Post C1

Return Event: 1 Year
 Storm Event: 1-Year

Time of Concentration Results

Segment #1: TR-55 Sheet Flow	
Hydraulic Length	100.00 ft
Manning's n	0.240
2 Year 24-Hour Depth	0.009 ft/ft
Average Velocity	3.5 in
Segment Time of Concentration	0.09 ft/s
	0.313 hours
Segment #2: TR-55 Shallow Concentrated Flow	
Hydraulic Length	238.00 ft
Is Paved?	False
Slope	0.015 ft/ft
Average Velocity	1.98 ft/s
Segment Time of Concentration	0.033 hours
Time of Concentration (Composite)	
Time of Concentration (Composite)	0.346 hours

Subsection: Time of Concentration Calculations
 Label: Post C1

Return Event: 1 years
 Storm Event: 1-Year

==== SCS Channel Flow

$$T_c = \frac{C_p \cdot L_f}{V} = \frac{C_p \cdot L_f}{(1.49 \cdot R^{0.487} \cdot S^{0.487}) / n}$$

Where:
 $C_p = 1.49 / 3600$
 R = Hydraulic radius
 A = Flow area, square feet
 W_p = Wetted perimeter, feet
 V = Velocity, ft/sec
 S = Slope, ft/ft
 T_c = Time of concentration, hours
 n = Manning's n
 L_f = Flow length, feet

==== SCS TR-55 Shallow Concentration Flow

Unpaved surface:
 $V = 16.1345 \cdot S^{0.5}$
 Paved Surface:
 $V = 20.3282 \cdot S^{0.5}$

Where:
 $C_p = 1.49 / 3600$
 V = Velocity, ft/sec
 S = Slope, ft/ft
 T_c = Time of concentration, hours
 L_f = Flow length, feet

Subsection: Time of Concentration Calculations
 Label: Post C2

Return Event: 1 years
 Storm Event: 1-Year

Time of Concentration Results

Segment #1: TR-55 Sheet Flow	
Hydraulic Length	30.00 ft
Manning's n	0.240
Slope	0.020 ft/ft
2 Year 24 Hour Depth	3.5 in
Average Velocity	0.10 ft/s
Segment Time of Concentration	0.087 hours
Segment #2: TR-55 Shallow Concentrated Flow	
Hydraulic Length	35.00 ft
Is Paved?	True
Slope	0.010 ft/ft
Average Velocity	2.03 ft/s
Segment Time of Concentration	0.005 hours
Segment #3: TR-55 Channel Flow	
Flow Area	1.8 ft ²
Hydraulic Length	407.00 ft
Manning's n	0.012
Slope	0.008 ft/ft
Wetted Perimeter	4.71 ft
Average Velocity	6.13 ft/s
Segment Time of Concentration	0.018 hours
Time of Concentration (Composite)	
Time of Concentration (Composite)	0.110 hours

Subsection: Time of Concentration Calculations
Label: Post C2

Return Event: 1 years
Storm Event: 1-Year

==== SCS Channel Flow

Tc = $R = Qp / Wp$
 $V = (1.49 * (R^{0.486} * (Sf^{0.0473})) * (Sf^{0.0473})) / n$
 $(L / V) / 3600$
 R= Hydraulic radius
 Aq= Flow area, square feet
 Wp= Wetted perimeter, feet
 Vp= Velocity, ft/sec
 Sf= Slope, ft/ft
 n= Manning's n
 Tc= Time of concentration, hours
 L= Flow length, feet

==== SCS TR-55 Shallow Concentration Flow

Unpaved surface:
 $V = 16.1345 * (Sf^{0.0473})$
 Paved Surface:
 $V = 20.3282 * (Sf^{0.0473})$
 $(L / V) / 3600$
 V= Velocity, ft/sec
 Sf= Slope, ft/ft
 Tc= Time of concentration, hours
 L= Flow length, feet

==== SCS TR-55 Sheet Flow

Tc = $(0.007 * ((n * L)^{0.6}) / ((P^{0.5}) * (Sf^{0.0473})) * (Sf^{0.0473})$
 Tc= Time of concentration, hours
 n= Manning's n
 L= Flow length, feet
 P= 24hr 24hr Rain depth, inches
 Sf= Slope, %

model3.ppc
3/5/2014

Bentley Systems, Inc. Headed Methods Solution Center
27 Siemon Company Drive Suite 200 W. Watertown, CT
06795 USA +1-203-755-1600

Bentley ProjectPack V8i
[08.11.01.56]
Page 37 of 203

Subsection: Time of Concentration Calculations
Label: Pre A

Return Event: 1 years
Storm Event: 1-Year

Time of Concentration Results

Segment #1: TR-55 Sheet Flow	
Hydraulic Length	100.00 ft
Manning's n	0.240
Slope	0.006 ft/ft
2 Year 24 Hour Depth	3.5 in
Average Velocity	0.07 ft/s
Segment Time of Concentration	0.376 hours
Segment #2: TR-55 Shallow Concentrated Flow	
Hydraulic Length	14.00 ft
Is Paved?	False
Slope	0.005 ft/ft
Average Velocity	1.14 ft/s
Segment Time of Concentration	0.003 hours
Segment #3: TR-55 Shallow Concentrated Flow	
Hydraulic Length	71.00 ft
Is Paved?	True
Slope	0.007 ft/ft
Average Velocity	1.70 ft/s
Segment Time of Concentration	0.012 hours
Segment #4: TR-55 Shallow Concentrated Flow	
Hydraulic Length	378.00 ft
Is Paved?	False
Slope	0.028 ft/ft
Average Velocity	2.70 ft/s
Segment Time of Concentration	0.039 hours
Segment #5: TR-55 Shallow Concentrated Flow	
Hydraulic Length	314.00 ft
Is Paved?	False
Slope	0.019 ft/ft
Average Velocity	2.22 ft/s
Segment Time of Concentration	0.039 hours
Time of Concentration (Composite)	
Time of Concentration (Composite)	0.469 hours

model3.ppc
3/5/2014

Bentley Systems, Inc. Headed Methods Solution Center
27 Siemon Company Drive Suite 200 W. Watertown, CT
06795 USA +1-203-755-1600

Bentley ProjectPack V8i
[08.11.01.56]
Page 38 of 203

Subsection: Time of Concentration Calculations
 Label: Pre A

Return Event: 1 years
 Storm Event: 1-Year

==== SCS Channel Flow

$$R = Q_p / W_p$$

$$V = (1.49 * (R^{0.486} * (2/3)) * (S^{0.486-0.5})) / n$$

$$(L_f / V) / 3600$$

R= Hydraulic radius
 A= Flow area, squares feet
 Wp= Wetted perimeter, feet
 V= Velocity, ft/sec
 S= Slope, ft/ft
 n= Manning's n
 Tc= Time of concentration, hours
 Lf= Flow length, feet

Tc =

Where:

==== SCS TR-55 Shallow Concentration Flow

Unpaved surface:
 $V = 16.1345 * (S^{0.486-0.5})$

Paved Surface:
 $V = 20.3282 * (S^{0.486-0.5})$

 $(L_f / V) / 3600$

V= Velocity, ft/sec
 S= Slope, ft/ft
 Tc= Time of concentration, hours
 Lf= Flow length, feet

Tc =

Where:

Subsection: Time of Concentration Calculations
 Label: Pre B

Return Event: 1 years
 Storm Event: 1-Year

Time of Concentration Results

Segment #1: TR-55 Sheet Flow	100.00 ft
Hydraulic Length	0.240
Manning's n	0.016 ft/ft
Slope	3.5 in
2 Year 24 Hour Depth	0.11 ft/s
Average Velocity	0.249 hours
Segment Time of Concentration	
Segment #2: TR-65 Shallow Concentrated Flow	237.00 ft
Hydraulic Length	False
Is Paved?	0.059 ft/ft
Slope	3.92 ft/s
Average Velocity	0.017 hours
Segment Time of Concentration	
Time of Concentration (Composite)	
Time of Concentration (Composite)	0.265 hours

med3d.jpc
 3/6/2014

Bentley Systems, Inc. Horizontal Methods Solution Center
 27 Siemon Company Drive Suite 200 W. Waterbury, CT
 06798 USA +1-203-755-1686

Bentley PondPack V8i
 [06.11.01.60]
 Page 39 of 203

med3d.jpc
 3/6/2014

Bentley Systems, Inc. Horizontal Methods Solution Center
 27 Siemon Company Drive Suite 200 W. Waterbury, CT
 06798 USA +1-203-755-1686

Bentley PondPack V8i
 [06.11.01.60]
 Page 40 of 203

Subsection: Time of Concentration Calculations
 Label: Pre B

Return Event: 1 years
 Storm Event: 1-Year

==== SCS Channel Flow

Tc =
$$R = Q_p / W_p$$

$$V = (1.49 * (R^{0.486} * S^{0.0478})) / n$$

$$(L_f / V) / 3600$$

R= Hydraulic radius
 Aq= Flow area, square feet
 Wp= Wetted perimeter, feet
 Vp= Velocity, ft/sec
 Sf= Slope, ft/ft
 n= Manning's n
 Tc= Time of concentration, hours
 Lf= Flow length, feet

Where:

==== SCS TR-55 Shallow Concentration Flow

Unpaved surface:

$$V = 16.1345 * (Sf^{0.5})$$
 Paved Surface:

$$V = 20.3282 * (Sf^{0.5})$$

$$(L_f / V) / 3600$$

V= Velocity, ft/sec
 Sf= Slope, ft/ft
 Tc= Time of concentration, hours
 Lf= Flow length, feet

Tc =

Where:

Subsection: Time of Concentration Calculations
 Label: Pre C

Return Event: 1 years
 Storm Event: 1-Year

Time of Concentration Results

Segment #1: TR-55 Sheet Flow	
Hydraulic Length	100.00 ft
Manning's n	0.240
Slope	0.009 ft/ft
2 Year 24-Hour Depth	3.5 in
Average Velocity	0.09 ft/s
Segment Time of Concentration	0.313 hours
Segment #2: TR-55 Shallow Concentrated Flow	
Hydraulic Length	332.00 ft
Is Paved?	False
Slope	0.015 ft/ft
Average Velocity	1.98 ft/s
Segment Time of Concentration	0.047 hours
Time of Concentration (Composite)	
Time of Concentration (Composite)	0.360 hours

Subsection: Time of Concentration Calculations
 Label: Pre C

Return Event: 1 years
 Storm Event: 1-Year

==== SCS Channel Flow

Tc = $R = Q_0 / W_p$
 $V = (1.49 * (R^{0.486} * (S^{1.486} * 0.5))) / n$

- (L / V) / 3600
- R= Hydraulic radius
- A₀= Flow area, square feet
- P₀= Wetted perimeter, feet
- V= Velocity, ft/sec
- S= Slope, ft/ft
- n= Manning's n
- Tc= Time of concentration, hours
- Lf= Flow length, feet

Where:

==== SCS TR-55 Shallow Concentration Flow

Unpaved surface:
 $V = 16.1345 * (S^{0.5})$
 Paved Surface:
 $V = 20.3282 * (S^{0.5})$

- (L / V) / 3600
- V= Velocity, ft/sec
- S= Slope, ft/ft
- Tc= Time of concentration, hours
- Lf= Flow length, feet

Where:

Subsection: Runoff CN-Area
 Label: Post A1

Return Event: 1 years
 Storm Event: 1-Year

Runoff Curve Number Data

Soil/Surface Description	CN	Area (Ac)	C (%)	UC (%)	Adjusted CN
Open space (Lawns, parks etc.) - Good condition; grass cover > 75% - Soil D	80,000	31,707	0,0	0,0	80,000
COMPOSITE AREA & WEIGHTED CN --->	(N/A)	31,707	(N/A)	(N/A)	80,000

Subsection: Runoff CN-Area
Label: Post A2

Return Event: 1 years
Storm Event: 1-Year

Runoff Curve Number Data

Soil/Surface Description	CN	Area (ft ²)	C (%)	UC (%)	Adjusted CN
Proposed Building	98.000	37,628	0.0	0.0	98.000
Proposed Pavement	98.000	51,993	0.0	0.0	98.000
Open space (Lawns,parks etc.) - Good condition; grass cover > 75% - Soil D	80.000	36,733	0.0	0.0	80.000
Stormwater Pond	100.000	5,200	0.0	0.0	100.000
COMPOSITE AREA & WEIGHTED CN --->	(N/A)	131,554	(N/A)	(N/A)	93.053

Subsection: Runoff CN-Area
Label: Post A3

Return Event: 1 years
Storm Event: 1-Year

Runoff Curve Number Data

Soil/Surface Description	CN	Area (ft ²)	C (%)	UC (%)	Adjusted CN
Impervious Areas - Paved parking lots, roofs, driveways, Streets and roads - Soil D	98.000	20,557	0.0	0.0	98.000
Open space (Lawns,parks etc.) - Good condition; grass cover > 75% - Soil D	80.000	2,130	0.0	0.0	80.000
COMPOSITE AREA & WEIGHTED CN --->	(N/A)	22,687	(N/A)	(N/A)	96.310

Subsection: Runoff CN-Area
Label: Post A4

Return Event: 1 years
Storm Event: 1-Year

Runoff Curve Number Data

Soil/Surface Description	CN	Area (ft ²)	C (%)	LC (%)	Adjusted CN
Impervious Areas - Paved parking lots, roofs, driveways, streets and roads - Soil D	98.000	7,618	0.0	0.0	98.000
Open space (Lawns,parks etc.) - Good condition; grass cover > 75% - Soil D	85.000	10,368	0.0	0.0	85.000
Brush - brush, weed, grass mix - good - Soil D	80.000	14,329	0.0	0.0	80.000
COMPOSITE AREA & WEIGHTED CN --->	(N/A)	32,315	(N/A)	(N/A)	85.848

model3.ppc
3/5/2014

Bentley Systems, Inc. - Headquarters Solution Center
27 Siemon Company Drive Suite 200 W. Watertown, CT
06795 USA +1-203-755-1996

Bentley PondPack V8i
(08.11.01.50)
Page 47 of 203

Subsection: Runoff CN-Area
Label: Post A5

Return Event: 1 years
Storm Event: 1-Year

Runoff Curve Number Data

Soil/Surface Description	CN	Area (ft ²)	C (%)	LC (%)	Adjusted CN
Impervious Areas - Paved parking lots, roofs, driveways, streets and roads - Soil D	98.000	20,254	0.0	0.0	98.000
Open space (Lawns,parks etc.) - Good condition; grass cover > 75% - Soil D	80.000	1,537	0.0	0.0	80.000
Brush - brush, weed, grass mix - good - Soil D	73.000	6,039	0.0	0.0	73.000
COMPOSITE AREA & WEIGHTED CN --->	(N/A)	27,830	(N/A)	(N/A)	91.581

model3.ppc
3/5/2014

Bentley Systems, Inc. - Headquarters Solution Center
27 Siemon Company Drive Suite 200 W. Watertown, CT
06795 USA +1-203-755-1996

Bentley PondPack V8i
(08.11.01.50)
Page 48 of 203

Subsection: Runoff CN-Area
Label: Post A6

Return Event: 1 years
Storm Event: 1-Year

Runoff Curve Number Data

Soil/Surface Description	CN	Area (ft ²)	C (%)	UC (%)	Adjusted CN
Impervious Areas - Paved parking lots, roofs, driveways, Streets and roads - Soil D	98.000	9,964	0.0	0.0	98.000
Brush - brush, weed, grass mix - good - Soil D	73.000	1,906	0.0	0.0	73.000
Open space (Lawns,parks etc.) - Good condition; grass cover > 75% - Soil D	80.000	445	0.0	0.0	80.000
COMPOSITE AREA & WEIGHTED CN ---->	(N/A)	12,315	(N/A)	(N/A)	93.480

model3.gps
3/5/2014

Bentley Systems, Inc. - Haestad Methods Solution Center
27 Siemon Company Drive Suite 200 W. Walltown, CT
06795 USA +1-203-755-1688

Bentley ProjectPack V8i
(05.11.01.60)
Page 49 of 203

Subsection: Runoff CN-Area
Label: Post A7

Return Event: 1 years
Storm Event: 1-Year

Runoff Curve Number Data

Soil/Surface Description	CN	Area (ft ²)	C (%)	UC (%)	Adjusted CN
Impervious Areas - Paved parking lots, roofs, driveways, Streets and roads - Soil D	98.000	2,976	0.0	0.0	98.000
Brush - brush, weed, grass mix - good - Soil D	73.000	3,064	0.0	0.0	73.000
Open space (Lawns,parks etc.) - Good condition; grass cover > 75% - Soil D	80.000	507	0.0	0.0	80.000
COMPOSITE AREA & WEIGHTED CN ---->	(N/A)	6,547	(N/A)	(N/A)	84.906

model3.gps
3/5/2014

Bentley Systems, Inc. - Haestad Methods Solution Center
27 Siemon Company Drive Suite 200 W. Walltown, CT
06795 USA +1-203-755-1688

Bentley ProjectPack V8i
(05.11.01.60)
Page 50 of 203

Subsection: Runoff CN-Area
Label: Post A8

Return Event: 1 years
Storm Event: 1-Year

Runoff Curve Number Data

Soil/Surface Description	CN	Area (Ft ²)	C (%)	UC (%)	Adjusted CN
Impervious Areas - Paved parking lots, roofs, driveways, Streets and roads - Soil D	98.000	14,012	0.0	0.0	98.000
Brush - brush, weed, grass mix - good - Soil D	73.000	2,917	0.0	0.0	73.000
Open space (Lawns,parks etc.) - Good condition; grass cover > 75% - Soil D	80.000	666	0.0	0.0	80.000
COMPOSITE AREA & WEIGHTED CN --->	(N/A)	17,595	(N/A)	(N/A)	93.174

Subsection: Runoff CN-Area
Label: Post A9

Return Event: 1 years
Storm Event: 1-Year

Runoff Curve Number Data

Soil/Surface Description	CN	Area (Ft ²)	C (%)	UC (%)	Adjusted CN
Impervious Areas - Paved parking lots, roofs, driveways, Streets and roads - Soil D	98.000	23,419	0.0	0.0	98.000
Brush - brush, weed, grass mix - good - Soil D	73.000	2,965	0.0	0.0	73.000
Open space (Lawns,parks etc.) - Good condition; grass cover > 75% - Soil D	80.000	602	0.0	0.0	80.000
COMPOSITE AREA & WEIGHTED CN --->	(N/A)	26,986	(N/A)	(N/A)	94.852

Subsection: Runoff CN-Area
Label: Post B1

Return Event: 1 years
Storm Event: 1-Year

Runoff Curve Number Data

Soil/Surface Description	CN	Area (ft ²)	C (%)	UC (%)	Adjusted CN
Open space (Lawns, parks, etc.) - Good condition; grass cover > 75% - Soil D	80,000	8,781	0.0	0.0	80,000
COMPOSITE AREA & WEIGHTED CN ---->	(N/A)	8,781	(N/A)	(N/A)	80,000

model: jpc
3/5/2014

Bentley Systems, Inc., Hoesdal Methods Solution Center
27 Siemon Company Drive Suite 200 W. Watertown, CT
06795 USA +1-203-755-1686

Bentley PondPack V8i
[08-11-01-50]
Page 53 of 203

Subsection: Runoff CN-Area
Label: Post B2

Return Event: 1 years
Storm Event: 1-Year

Runoff Curve Number Data

Soil/Surface Description	CN	Area (ft ²)	C (%)	UC (%)	Adjusted CN
Impervious Areas - Paved parking lots, roofs, driveways, streets and roads - Soil D	98,000	8,192	0.0	0.0	98,000
Open space (Lawns, parks, etc.) - Good condition; grass cover > 75% - Soil D	80,000	4,580	0.0	0.0	80,000
COMPOSITE AREA & WEIGHTED CN ---->	(N/A)	12,772	(N/A)	(N/A)	91,545

model: jpc
3/5/2014

Bentley Systems, Inc., Hoesdal Methods Solution Center
27 Siemon Company Drive Suite 200 W. Watertown, CT
06795 USA +1-203-755-1686

Bentley PondPack V8i
[08-11-01-50]
Page 54 of 203

Subsection: Runoff CN-Area
Label: Post C1

Return Event: 1 years
Storm Event: 1--Year

Runoff Curve Number Data

Soil/Surface Description	CN	Area (ft ²)	C (%)	LC (%)	Adjusted CN
Open space (Lawns, parks etc.) - Good condition, grass cover > 75% - Soil D	80.000	11,710	0.0	0.0	80.000
COMPOSITE AREA & WEIGHTED CN ---->	(N/A)	11,710	(N/A)	(N/A)	80.000

Subsection: Runoff CN-Area
Label: Post C2

Return Event: 1 years
Storm Event: 1--Year

Runoff Curve Number Data

Soil/Surface Description	CN	Area (ft ²)	C (%)	LC (%)	Adjusted CN
Open space (Lawns, parks etc.) - Good condition; grass cover > 75% - Soil D	80.000	13,283	0.0	0.0	80.000
Impervious Areas - Paved parking lots, roofs, driveways, Streets and roads - Soil D	98.000	39,144	0.0	0.0	98.000
COMPOSITE AREA & WEIGHTED CN ---->	(N/A)	52,427	(N/A)	(N/A)	93.439

Subsection: Runoff CN-Area
 Label: Pre A

Return Event: 1 years
 Storm Event: 1-Year

Runoff Curve Number Data

Soil/Surface Description	CN	Area (F ²)	C (%)	UC (%)	Adjusted CN
Buildings	98.000	14,344	0.0	0.0	98.000
Driveways	98.000	28,848	0.0	0.0	98.000
Roads	98.000	12,083	0.0	0.0	98.000
Woods - fair - Soil D	79.000	110,567	0.0	0.0	79.000
Open space (Lawns,parks etc.) - Fair condition; grass cover 50% to 75% - Soil D	84.000	134,794	0.0	0.0	84.000
COMPOSITE AREA & WEIGHTED CN --->	(N/A)	300,636	(N/A)	(N/A)	84.735

Subsection: Runoff CN-Area
 Label: Pre B

Return Event: 1 years
 Storm Event: 1-Year

Runoff Curve Number Data

Soil/Surface Description	CN	Area (F ²)	C (%)	UC (%)	Adjusted CN
Woods - fair - Soil D	79.000	8,823	0.0	0.0	79.000
Open space (Lawns,parks etc.) - Fair condition; grass cover 50% to 75% - Soil D	84.000	26,984	0.0	0.0	84.000
Buildings	98.000	79	0.0	0.0	98.000
COMPOSITE AREA & WEIGHTED CN --->	(N/A)	35,886	(N/A)	(N/A)	82.802

Subsection: Runoff CN-Area
Label: Pre C

Return Event: 1 years
Storm Event: 1-Year

Runoff Curve Number Data

Soil/Surface Description	CN	Area (ft ²)	C (%)	UC (%)	Adjusted CN
Buildings	98.000	3,104	0.0	0.0	98.000
Driveways	98.000	9,260	0.0	0.0	98.000
Woods - fair - Soil D	79.000	4,196	0.0	0.0	79.000
Open space (Lawns, parks etc.) - Fair condition; grass cover 50% to 75% - Soil D	84.000	54,389	0.0	0.0	84.000
Roads	98.000	1,500	0.0	0.0	98.000
COMPOSITE AREA & WEIGHTED CN -->	(N/A)	72,449	(N/A)	(N/A)	86,389

Subsection: Unit Hydrograph Summary
Label: Post A1

Return Event: 1 years
Storm Event: 1-Year

Storm Event	1-Year
Return Event	1 years
Duration	24,000 hours
Depth	2.9 in
Time of Concentration (Composite)	0.091 hours
Area (User Defined)	31,707 ft ²
Computational Time	0.012 hours
Time to Peak (Computed)	12.107 hours
Flow (Peak, Computed)	0.88 ft ³ /s
Output Increment	0.050 hours
Time to Flow (Peak Interpolated Output)	12.100 hours
Flow (Peak Interpolated Output)	0.88 ft ³ /s
Drainage Area	
SCS CN (Composite)	80.000
Area (User Defined)	31,707 ft ²
Maximum Retention (Previous)	2.5 in
Maximum Retention (Previous, 20 percent)	0.5 in
Cumulative Runoff	
Cumulative Runoff Depth (Previous)	1.2 in
Runoff Volume (Previous)	3,106 ft ³
Hydrograph Volume (Area under Hydrograph curve)	
Volumes	3,102 ft ³
SCS Unit Hydrograph Parameters	
Time of Concentration (Composite)	0.091 hours
Computational Time Increment	0.012 hours
Unit Hydrograph Shape Factor	483.432
K Factor	0.749
Receding/Rising, Tr/Tp	1.670
Unit peak, qp	9.06 ft ³ /s
Unit peak time, Tp	0.061 hours
Unit receding limb, Tr	0.243 hours
Total unit time, Tb	0.303 hours

Subsection: Unit Hydrograph Summary
Label: Post A1

Return Event: 10 years
Storm Event: 10-Year

Storm Event	10-Year
Return Event	10 years
Duration	24,000 hours
Depth	5.5 in
Time of Concentration (Composite)	0.091 hours
Area (User Defined)	31,707 ft ²
Computational Time Increment	0.012 hours
Time to Peak (Computed)	12.107 hours
Flow (Peak, Computed)	2.49 ft ³ /s
Output Increment	0.050 hours
Time to Flow (Peak Interpolated Output)	12.100 hours
Flow (Peak Interpolated Output)	2.48 ft ³ /s
Drainage Area	
SCS CN (Composite)	80.000
Area (User Defined)	31,707 ft ²
Maximum Retention (Previous)	2.5 in
Maximum Retention (Previous, 20 percent)	0.5 in
Cumulative Runoff	
Cumulative Runoff Depth (Previous)	3.3 in
Runoff Volume (Previous)	8,808 ft ³
Hydrograph Volume (Area under Hydrograph curve)	
Volume	8,799 ft ³
SCS Unit Hydrograph Parameters	
Time of Concentration (Composite)	0.091 hours
Computational Time Increment	0.012 hours
Unit Hydrograph Shape Factor	483.432
K Factor	0.749
Recoding/Rising, Tr/Tp	1.670
Unit peak, qp	9.06 ft ³ /s
Unit peak time, Tp	0.061 hours
Unit receding limb, Tr	0.243 hours
Total unit time, Tb	0.303 hours

Subsection: Unit Hydrograph Summary
Label: Post A1

Return Event: 100 years
Storm Event: 100-Year

Storm Event	100-Year
Return Event	100 years
Duration	24,000 hours
Depth	8.0 in
Time of Concentration (Composite)	0.091 hours
Area (User Defined)	31,707 ft ²
Computational Time Increment	0.012 hours
Time to Peak (Computed)	12.107 hours
Flow (Peak, Computed)	4.10 ft ³ /s
Output Increment	0.050 hours
Time to Flow (Peak Interpolated Output)	12.100 hours
Flow (Peak Interpolated Output)	4.09 ft ³ /s
Drainage Area	
SCS CN (Composite)	80.000
Area (User Defined)	31,707 ft ²
Maximum Retention (Previous)	2.5 in
Maximum Retention (Previous, 20 percent)	0.5 in
Cumulative Runoff	
Cumulative Runoff Depth (Previous)	5.6 in
Runoff Volume (Previous)	14,963 ft ³
Hydrograph Volume (Area under Hydrograph curve)	
Volume	14,850 ft ³
SCS Unit Hydrograph Parameters	
Time of Concentration (Composite)	0.091 hours
Computational Time Increment	0.012 hours
Unit Hydrograph Shape Factor	483.432
K Factor	0.749
Recoding/Rising, Tr/Tp	1.670
Unit peak, qp	9.06 ft ³ /s
Unit peak time, Tp	0.061 hours
Unit receding limb, Tr	0.243 hours
Total unit time, Tb	0.303 hours

Subsection: Unit Hydrograph Summary
Label: Post A2

Return Event: 1 years
Storm Event: 1-Year

Storm Event	1-Year
Return Event	1 years
Duration	24,000 hours
Depth	2.9 in
Time of Concentration (Composite)	0.142 hours
Area (User Defined)	131,554 ft ²
Computational Time	
Increment	0.019 hours
Time to Peak (Computed)	12.118 hours
Flow Peak (Computed)	6.17 ft ³ /s
Output Increment	0.050 hours
Time to Flow Peak Interpolated Output	12.100 hours
Flow Peak Interpolated Output	6.10 ft ³ /s
Drainage Area	
SCS CN (Composite)	93.000
Area (User Defined)	131,554 ft ²
Maximum Retention (Pervious)	0.8 in
Maximum Retention (Pervious, 20 percent)	0.2 in
Cumulative Runoff	
Cumulative Runoff Depth (Pervious)	2.2 in
Runoff Volume (Pervious)	23,664 ft ³
Hydrograph Volume (Area under Hydrograph curve)	
Volume	23,633 ft ³
SCS Unit Hydrograph Parameters	
Time of Concentration (Composite)	0.142 hours
Computational Time Increment	0.019 hours
Unit Hydrograph Shape Factor	483.432
K Factor	0.749
Receding/Rising, Tr/Tp	1.670
Unit peak, qp	24.13 ft ³ /s
Unit peak time, Tp	0.095 hours
Unit receding limb, Tr	0.378 hours
Total unit time, Td	0.473 hours

Bentley PondPack V8i
[08.11.01.66]
Page 63 of 203

model3.ppc
3/5/2014

Bentley Systems, Inc. Headend Methods Solution Center
27 Siemon Company Drive Sub 200 W. Watertown, CT
06795 USA +1-203-755-1686

Subsection: Unit Hydrograph Summary
Label: Post A2

Return Event: 10 years
Storm Event: 10-Year

Storm Event	10-Year
Return Event	10 years
Duration	24,000 hours
Depth	5.5 in
Time of Concentration (Composite)	0.142 hours
Area (User Defined)	131,554 ft ²
Computational Time	
Increment	0.019 hours
Time to Peak (Computed)	12.118 hours
Flow Peak (Computed)	12.82 ft ³ /s
Output Increment	0.050 hours
Time to Flow Peak Interpolated Output	12.100 hours
Flow Peak Interpolated Output	12.71 ft ³ /s
Drainage Area	
SCS CN (Composite)	93.000
Area (User Defined)	131,554 ft ²
Maximum Retention (Pervious)	0.8 in
Maximum Retention (Pervious, 20 percent)	0.2 in
Cumulative Runoff	
Cumulative Runoff Depth (Pervious)	4.7 in
Runoff Volume (Pervious)	51,411 ft ³
Hydrograph Volume (Area under Hydrograph curve)	
Volume	51,352 ft ³
SCS Unit Hydrograph Parameters	
Time of Concentration (Composite)	0.142 hours
Computational Time Increment	0.019 hours
Unit Hydrograph Shape Factor	483.432
K Factor	0.749
Receding/Rising, Tr/Tp	1.670
Unit peak, qp	24.13 ft ³ /s
Unit peak time, Tp	0.095 hours
Unit receding limb, Tr	0.378 hours
Total unit time, Td	0.473 hours

Bentley Systems, Inc. Headend Methods Solution Center
27 Siemon Company Drive Sub 200 W. Watertown, CT
06795 USA +1-203-755-1686

model3.ppc
3/5/2014

Bentley PondPack V8i
[08.11.01.66]
Page 84 of 203

Subsection: Unit Hydrograph Summary
Label: Post A2

Return Event: 100 years
Storm Event: 100-Year

Storm Event	100-Year
Return Event	100 years
Duration	24,000 hours
Depth	8.0 in
Time of Concentration (Composite)	0.142 hours
Area (User Defined)	131,554 ft ²
Computational Time	
Increment	0.019 hours
Time to Peak (Computed)	12.118 hours
Flow (Peak, Computed)	19.11 ft ³ /s
Output Increment	0.050 hours
Time to Flow (Peak Interpolated Output)	12.100 hours
Flow (Peak Interpolated Output)	18.96 ft ³ /s
Drainage Area	
SCS CN (Composite)	93.000
Area (User Defined)	131,554 ft ²
Maximum Retention (Pervious)	0.8 in
Maximum Retention (Pervious, 20 percent)	0.2 in
Cumulative Runoff	
Cumulative Runoff Depth (Pervious)	7.2 in
Runoff Volume (Pervious)	78,523 ft ³
Hydrograph Volume (Area under Hydrograph curve)	
Volume	78,435 ft ³
SCS Unit Hydrograph Parameters	
Time of Concentration (Composite)	0.142 hours
Computational Time Increment	0.019 hours
Unit Hydrograph Shape Factor	483.432
K Factor	0.749
Receding/Rising, Tr/Tp	1.670
Unit peak, qp	24.13 ft ³ /s
Unit peak time, Tp	0.095 hours
Unit receding limb, Tr	0.378 hours
Total unit time, Tb	0.473 hours

Subsection: Unit Hydrograph Summary
Label: Post A3

Return Event: 1 years
Storm Event: 1-Year

Storm Event	1-Year
Return Event	1 years
Duration	24,000 hours
Depth	2.5 in
Time of Concentration (Composite)	0.094 hours
Area (User Defined)	22,687 ft ²
Computational Time	
Increment	0.013 hours
Time to Peak (Computed)	12.107 hours
Flow (Peak, Computed)	1.20 ft ³ /s
Output Increment	0.050 hours
Time to Flow (Peak Interpolated Output)	12.100 hours
Flow (Peak Interpolated Output)	1.20 ft ³ /s
Drainage Area	
SCS CN (Composite)	96.000
Area (User Defined)	22,687 ft ²
Maximum Retention (Pervious)	0.4 in
Maximum Retention (Pervious, 20 percent)	0.1 in
Cumulative Runoff	
Cumulative Runoff Depth (Pervious)	2.5 in
Runoff Volume (Pervious)	4,639 ft ³
Hydrograph Volume (Area under Hydrograph curve)	
Volume	4,635 ft ³
SCS Unit Hydrograph Parameters	
Time of Concentration (Composite)	0.094 hours
Computational Time Increment	0.013 hours
Unit Hydrograph Shape Factor	483.432
K Factor	0.749
Receding/Rising, Tr/Tp	1.670
Unit peak, qp	6.27 ft ³ /s
Unit peak time, Tp	0.063 hours
Unit receding limb, Tr	0.251 hours
Total unit time, Tb	0.314 hours

Subsection: Unit Hydrograph Summary
Label: Post A3

Return Event: 10 years
Storm Event: 10-Year

Storm Event	10-Year
Return Event	10 years
Duration	24,000 hours
Depth	5.5 in
Time of Concentration (Composite)	0.094 hours
Area (User Defined)	22,687 ft ²
Computational Time	
Increment	0.013 hours
Time to Peak (Computed)	12.095 hours
Flow (Peak, Computed)	2.36 ft ³ /s
Output Increment	0.050 hours
Time to Flow (Peak Interpolated Output)	12.100 hours
Flow (Peak Interpolated Output)	2.36 ft ³ /s
Drainage Area	
SCS CN (Composite)	96.000
Area (User Defined)	22,687 ft ²
Maximum Retention (Pervious)	0.4 in
Maximum Retention (Pervious, 20 percent)	0.1 in
Cumulative Runoff	
Cumulative Runoff Depth (Pervious)	5.0 in
Runoff Volume (Pervious)	9,509 ft ³
Hydrograph Volume (Area under Hydrograph curve)	
Volume	9,502 ft ³
SCS Unit Hydrograph Parameters	
Time of Concentration (Composite)	0.094 hours
Computational Time Increment	0.013 hours
Unit Hydrograph Shape Factor	483.432
K Factor	0.749
Receding/Rising, T _r /T _p	1.670
Unit peak, q _p	6.27 ft ³ /s
Unit peak time, T _p	0.063 hours
Unit receding limb, T _r	0.251 hours
Total unit time, T _b	0.314 hours

Subsection: Unit Hydrograph Summary
Label: Post A3

Return Event: 100 years
Storm Event: 100-Year

Storm Event	100-Year
Return Event	100 years
Duration	24,000 hours
Depth	8.0 in
Time of Concentration (Composite)	0.094 hours
Area (User Defined)	22,687 ft ²
Computational Time	
Increment	0.013 hours
Time to Peak (Computed)	12.095 hours
Flow (Peak, Computed)	3.47 ft ³ /s
Output Increment	0.050 hours
Time to Flow (Peak Interpolated Output)	12.100 hours
Flow (Peak Interpolated Output)	3.47 ft ³ /s
Drainage Area	
SCS CN (Composite)	96.000
Area (User Defined)	22,687 ft ²
Maximum Retention (Pervious)	0.4 in
Maximum Retention (Pervious, 20 percent)	0.1 in
Cumulative Runoff	
Cumulative Runoff Depth (Pervious)	7.5 in
Runoff Volume (Pervious)	14,219 ft ³
Hydrograph Volume (Area under Hydrograph curve)	
Volume	14,209 ft ³
SCS Unit Hydrograph Parameters	
Time of Concentration (Composite)	0.094 hours
Computational Time Increment	0.013 hours
Unit Hydrograph Shape Factor	483.432
K Factor	0.749
Receding/Rising, T _r /T _p	1.670
Unit peak, q _p	6.27 ft ³ /s
Unit peak time, T _p	0.063 hours
Unit receding limb, T _r	0.251 hours
Total unit time, T _b	0.314 hours

Subsection: Unit Hydrograph Summary
Label: Post_A4

Return Event: 1 years
Storm Event: 1-Year

Storm Event	1-Year
Return Event	1 years
Duration	24,000 hours
Depth	2.9 in
Time of Concentration (Composite)	0.095 hours
Area (User Defined)	32,315 ft ²
Computational Time Increment	0.013 hours
Time to Peak (Computed)	12.116 hours
Flow (Peak, Computed)	1.20 ft ³ /s
Output Increment	0.050 hours
Time to Flow (Peak Interpolated Output)	12.100 hours
Flow (Peak, Interpolated Output)	1.20 ft ³ /s
Drainage Area	
SCS CN (Composite)	86.000
Area (User Defined)	32,315 ft ²
Maximum Retention (Pervious)	1.6 in
Maximum Retention (Pervious, 20 percent)	0.3 in
Cumulative Runoff	
Cumulative Runoff Depth (Pervious)	1.6 in
Runoff Volume (Pervious)	4,247 ft ³
Hydrograph Volume (Area under Hydrograph curve)	
Volume	4,243 ft ³
SCS Unit Hydrograph Parameters	
Time of Concentration (Composite)	0.095 hours
Computational Time Increment	0.013 hours
Unit Hydrograph Shape Factor	483.432
K Factor	0.749
Receding/Rising, Tr/Tp	1.670
Unit peak, qp	8.82 ft ³ /s
Unit peak time, Tp	0.064 hours
Unit receding limb, Tr	0.254 hours
Total unit time, Tb	0.318 hours

Subsection: Unit Hydrograph Summary
Label: Post_A4

Return Event: 10 years
Storm Event: 10-Year

Storm Event	10-Year
Return Event	10 years
Duration	24,000 hours
Depth	5.5 in
Time of Concentration (Composite)	0.095 hours
Area (User Defined)	32,315 ft ²
Computational Time Increment	0.013 hours
Time to Peak (Computed)	12.103 hours
Flow (Peak, Computed)	2.90 ft ³ /s
Output Increment	0.050 hours
Time to Flow (Peak Interpolated Output)	12.100 hours
Flow (Peak, Interpolated Output)	2.90 ft ³ /s
Drainage Area	
SCS CN (Composite)	86.000
Area (User Defined)	32,315 ft ²
Maximum Retention (Pervious)	1.6 in
Maximum Retention (Pervious, 20 percent)	0.3 in
Cumulative Runoff	
Cumulative Runoff Depth (Pervious)	3.9 in
Runoff Volume (Pervious)	10,600 ft ³
Hydrograph Volume (Area under Hydrograph curve)	
Volume	10,590 ft ³
SCS Unit Hydrograph Parameters	
Time of Concentration (Composite)	0.095 hours
Computational Time Increment	0.013 hours
Unit Hydrograph Shape Factor	483.432
K Factor	0.749
Receding/Rising, Tr/Tp	1.670
Unit peak, qp	8.82 ft ³ /s
Unit peak time, Tp	0.064 hours
Unit receding limb, Tr	0.254 hours
Total unit time, Tb	0.318 hours

Subsection: Unit Hydrograph Summary
Label: Post A4

Return Event: 100 years
Storm Event: 100-Year

Storm Event	100-Year
Return Event	100 years
Duration	24,000 hours
Depth	8.0 in
Time of Concentration (Composite)	0.095 hours
Area (User Defined)	32,315 ft ²
Computational Time Increment	0.013 hours
Time to Peak (Computed)	12.103 hours
Flow (Peak, Computed)	4.54 ft ³ /s
Output Increment	0.050 hours
Time to Flow (Peak Interpolated Output)	12.100 hours
Flow (Peak Interpolated Output)	4.54 ft ³ /s
Drainage Area	
SCS CN (Composite)	86.000
Area (User Defined)	32,315 ft ²
Maximum Retention (Pervious)	1.6 in
Maximum Retention (Pervious, 20 percent)	0.3 in
Cumulative Runoff	
Cumulative Runoff Depth (Pervious)	6.3 in
Runoff Volume (Pervious)	17,050 ft ³
Hydrograph Volume (Area under Hydrograph curve)	
Volume	17,036 ft ³
SCS Unit Hydrograph Parameters	
Time of Concentration (Composite)	0.095 hours
Computational Time Increment	0.013 hours
Unit Hydrograph Shape Factor	483.432
K Factor	0.749
Recoding/Rising, Tr/Tp	1.670
Unit peak, qp	8.82 ft ³ /s
Unit peak time, Tp	0.064 hours
Unit receding limb, Tr	0.254 hours
Total unit time, Td	0.318 hours

Bentley PondPack V8i
[08.11.01.20]
Page 71 of 203

Bentley Systems, Inc. Harland Methods Solution Center
27 Sherman Company Drive Suite 200 W. Watertown, CT
06795 USA +1-203-755-1696

model.ppe
3/5/2014

Subsection: Unit Hydrograph Summary
Label: Post A5

Return Event: 1 years
Storm Event: 1-Year

Storm Event	1-Year
Return Event	1 years
Duration	24,000 hours
Depth	2.3 in
Time of Concentration (Composite)	0.189 hours
Area (User Defined)	27,830 ft ²
Computational Time Increment	0.025 hours
Time to Peak (Computed)	12.156 hours
Flow (Peak, Computed)	1.19 ft ³ /s
Output Increment	0.050 hours
Time to Flow (Peak Interpolated Output)	12.150 hours
Flow (Peak Interpolated Output)	1.19 ft ³ /s
Drainage Area	
SCS CN (Composite)	92.000
Area (User Defined)	27,830 ft ²
Maximum Retention (Pervious)	0.9 in
Maximum Retention (Pervious, 20 percent)	0.2 in
Cumulative Runoff	
Cumulative Runoff Depth (Pervious)	2.1 in
Runoff Volume (Pervious)	4,793 ft ³
Hydrograph Volume (Area under Hydrograph curve)	
Volume	4,785 ft ³
SCS Unit Hydrograph Parameters	
Time of Concentration (Composite)	0.189 hours
Computational Time Increment	0.025 hours
Unit Hydrograph Shape Factor	483.432
K Factor	0.749
Recoding/Rising, Tr/Tp	1.670
Unit peak, qp	3.84 ft ³ /s
Unit peak time, Tp	0.126 hours
Unit receding limb, Tr	0.503 hours
Total unit time, Td	0.629 hours

Bentley Systems, Inc. Harland Methods Solution Center
27 Sherman Company Drive Suite 200 W. Watertown, CT
06795 USA +1-203-755-1696

Bentley PondPack V8i
[08.11.01.20]
Page 72 of 203

model.ppe
3/5/2014

Subsection: Unit Hydrograph Summary
Label: Post A5

Return Event: 10 years
Storm Event: 10-Year

Storm Event	10-Year
Return Event	10 years
Duration	24,000 hours
Depth	5.5 in
Time of Concentration (Composite)	0.189 hours
Area (User Defined)	27,830 ft ²
Computational Time Increment	0.025 hours
Time to Peak (Computed)	12.130 hours
Flow (Peak, Computed)	2.53 ft ³ /s
Output Increment	0.050 hours
Time to Flow (Peak Interpolated Output)	12.150 hours
Flow (Peak Interpolated Output)	2.53 ft ³ /s
Drainage Area	
SCS CN (Composite)	92.000
Area (User Defined)	27,830 ft ²
Maximum Retention (Pervious)	0.9 in
Maximum Retention (Pervious, 20 percent)	0.2 in
Cumulative Runoff	
Cumulative Runoff Depth (Pervious)	4.6 in
Runoff Volume (Pervious)	10,618 ft ³
Hydrograph Volume (Area under Hydrograph curve)	
Volume	10,602 ft ³
SCS Unit Hydrograph Parameters	
Time of Concentration (Composite)	0.189 hours
Computational Time Increment	0.025 hours
Unit Hydrograph Shape Factor	483.432
K Factor	0.749
Receding/Rising, Tr/Tp	1.670
Unit peak, qp	3.84 ft ³ /s
Unit peak time, Tp	0.126 hours
Unit receding limb, Tr	0.503 hours
Total unit time, Tb	0.629 hours

Subsection: Unit Hydrograph Summary
Label: Post A5

Return Event: 100 years
Storm Event: 100-Year

Storm Event	100-Year
Return Event	100 years
Duration	24,000 hours
Depth	8.0 in
Time of Concentration (Composite)	0.189 hours
Area (User Defined)	27,830 ft ²
Computational Time Increment	0.025 hours
Time to Peak (Computed)	12.130 hours
Flow (Peak, Computed)	3.80 ft ³ /s
Output Increment	0.050 hours
Time to Flow (Peak Interpolated Output)	12.150 hours
Flow (Peak Interpolated Output)	3.79 ft ³ /s
Drainage Area	
SCS CN (Composite)	92.000
Area (User Defined)	27,830 ft ²
Maximum Retention (Pervious)	0.9 in
Maximum Retention (Pervious, 20 percent)	0.2 in
Cumulative Runoff	
Cumulative Runoff Depth (Pervious)	7.0 in
Runoff Volume (Pervious)	16,335 ft ³
Hydrograph Volume (Area under Hydrograph curve)	
Volume	16,311 ft ³
SCS Unit Hydrograph Parameters	
Time of Concentration (Composite)	0.189 hours
Computational Time Increment	0.025 hours
Unit Hydrograph Shape Factor	483.432
K Factor	0.749
Receding/Rising, Tr/Tp	1.670
Unit peak, qp	3.84 ft ³ /s
Unit peak time, Tp	0.126 hours
Unit receding limb, Tr	0.503 hours
Total unit time, Tb	0.629 hours

Subsection: Unit Hydrograph Summary
Label: Post A6

Return Event: 1 years
Storm Event: 1-Year

Storm Event	1-Year
Return Event	1 years
Duration	24,000 hours
Depth	2.9 in
Time of Concentration (Composite)	0.161 hours
Area (User Defined)	12,315 ft ²
Computational Time Increment	0.022 hours
Time to Peak (Computed)	12.129 hours
Flow (Peak, Computed)	0.56 ft ³ /s
Output Increment	0.050 hours
Time to Flow (Peak Interpolated Output)	12.150 hours
Flow (Peak Interpolated Output)	0.56 ft ³ /s
Drainage Area	
SCS CN (Composite)	93.000
Area (User Defined)	12,315 ft ²
Maximum Retention (Pervious)	0.8 in
Maximum Retention (Pervious, 20 percent)	0.2 in
Cumulative Runoff	
Cumulative Runoff Depth (Pervious)	2.2 in
Runoff Volume (Pervious)	2,215 ft ³
Hydrograph Volume (Area under Hydrograph curve)	
Volume	2,212 ft ³
SCS Unit Hydrograph Parameters	
Time of Concentration (Composite)	0.161 hours
Computational Time Increment	0.022 hours
Unit Hydrograph Shape Factor	483.432
K Factor	0.749
Receding/Rising, Tr/Tp	1.670
Unit peak, qp	1.99 ft ³ /s
Unit peak time, Tp	0.108 hours
Unit receding limb, Tr	0.430 hours
Total unit time, Tb	0.538 hours

Subsection: Unit Hydrograph Summary
Label: Post A6

Return Event: 10 years
Storm Event: 10-Year

Storm Event	10-Year
Return Event	10 years
Duration	24,000 hours
Depth	5.5 in
Time of Concentration (Composite)	0.161 hours
Area (User Defined)	12,315 ft ²
Computational Time Increment	0.022 hours
Time to Peak (Computed)	12.129 hours
Flow (Peak, Computed)	1.17 ft ³ /s
Output Increment	0.050 hours
Time to Flow (Peak Interpolated Output)	12.150 hours
Flow (Peak Interpolated Output)	1.15 ft ³ /s
Drainage Area	
SCS CN (Composite)	93.000
Area (User Defined)	12,315 ft ²
Maximum Retention (Pervious)	0.8 in
Maximum Retention (Pervious, 20 percent)	0.2 in
Cumulative Runoff	
Cumulative Runoff Depth (Pervious)	4.7 in
Runoff Volume (Pervious)	4,813 ft ³
Hydrograph Volume (Area under Hydrograph curve)	
Volume	4,807 ft ³
SCS Unit Hydrograph Parameters	
Time of Concentration (Composite)	0.161 hours
Computational Time Increment	0.022 hours
Unit Hydrograph Shape Factor	483.432
K Factor	0.749
Receding/Rising, Tr/Tp	1.670
Unit peak, qp	1.99 ft ³ /s
Unit peak time, Tp	0.108 hours
Unit receding limb, Tr	0.430 hours
Total unit time, Tb	0.538 hours

Subsection: Unit Hydrograph Summary
Label: Post A6

Return Event: 100 years
Storm Event: 100-Year

Storm Event	100-Year
Return Event	100 years
Duration	24,000 hours
Depth	8.0 in
Time of Concentration (Composite)	0.161 hours
Area (User Defined)	12,315 ft ²
Computational Time Increment	0.022 hours
Time to Peak (Computed)	12.129 hours
Flow (Peak, Computed)	1.75 ft ³ /s
Output Increment	0.050 hours
Time to Flow (Peak Interpolated Output)	12.100 hours
Flow (Peak Interpolated Output)	1.72 ft ³ /s
Drainage Area	
SCS CN (Composite)	93.000
Area (User Defined)	12,315 ft ²
Maximum Retention (Pervious)	0.8 in
Maximum Retention (Pervious, 20 percent)	0.2 in
Cumulative Runoff	
Cumulative Runoff Depth (Pervious)	7.2 in
Runoff Volume (Pervious)	7,351 ft ³
Hydrograph Volume (Area under Hydrograph curve)	
Volume	7,342 ft ³
SCS Unit Hydrograph Parameters	
Time of Concentration (Composite)	0.161 hours
Computational Time Increment	0.022 hours
Unit Hydrograph Shape Factor	483.432
K Factor	0.749
Receding/Rising, Tr/Tp	1.670
Unit peak, qp	1.59 ft ³ /s
Unit peak time, Tp	0.108 hours
Unit receding limb, Tr	0.430 hours
Total unit time, Tb	0.538 hours

Subsection: Unit Hydrograph Summary
Label: Post A7

Return Event: 1 years
Storm Event: 1-Year

Storm Event	1-Year
Return Event	1 years
Duration	24,000 hours
Depth	2.9 in
Time of Concentration (Composite)	0.118 hours
Area (User Defined)	6,547 ft ²
Computational Time Increment	0.016 hours
Time to Peak (Computed)	12.121 hours
Flow (Peak, Computed)	0.23 ft ³ /s
Output Increment	0.050 hours
Time to Flow (Peak Interpolated Output)	12.100 hours
Flow (Peak Interpolated Output)	0.22 ft ³ /s
Drainage Area	
SCS CN (Composite)	85.000
Area (User Defined)	6,547 ft ²
Maximum Retention (Pervious)	1.8 in
Maximum Retention (Pervious, 20 percent)	0.4 in
Cumulative Runoff	
Cumulative Runoff Depth (Pervious)	1.5 in
Runoff Volume (Pervious)	821 ft ³
Hydrograph Volume (Area under Hydrograph curve)	
Volume	820 ft ³
SCS Unit Hydrograph Parameters	
Time of Concentration (Composite)	0.118 hours
Computational Time Increment	0.016 hours
Unit Hydrograph Shape Factor	483.432
K Factor	0.749
Receding/Rising, Tr/Tp	1.670
Unit peak, qp	1.44 ft ³ /s
Unit peak time, Tp	0.079 hours
Unit receding limb, Tr	0.315 hours
Total unit time, Tb	0.394 hours

Subsection: Unit Hydrograph Summary
Label: Post A7

Return Event: 10 years
Storm Event: 10-Year

Storm Event	10-Year
Return Event	10 years
Duration	24,000 hours
Depth	5.5 in
Time of Concentration (Composite)	0.118 hours
Area (User Defined)	6,547 ft ²
<hr/>	
Computational Time Increment	0.016 hours
Time to Peak (Computed)	12.105 hours
Flow (Peak, Computed)	0.56 ft ³ /s
Output Increment	0.050 hours
Time to Flow (Peak Interpolated Output)	12.100 hours
Flow (Peak Interpolated Output)	0.56 ft ³ /s
<hr/>	
Drainage Area	
SCS CN (Composite)	85.000
Area (User Defined)	6,547 ft ²
Maximum Retention (Pervious)	1.8 in
Maximum Retention (Pervious, 20 percent)	0.4 in
<hr/>	
Cumulative Runoff	
Cumulative Runoff Depth (Pervious)	3.8 in
Runoff Volume (Pervious)	2,091 ft ³
<hr/>	
Hydrograph Volume (Area under Hydrograph curve)	
Volume	2,089 ft ³
<hr/>	
SCS Unit Hydrograph Parameters	
Time of Concentration (Composite)	0.118 hours
Computational Time Increment	0.016 hours
Unit Hydrograph Shape Factor	483.432
K Factor	0.749
Receding/Rising, Tr/Tp	1.670
Unit peak, qp	1.44 ft ³ /s
Unit peak time, Tp	0.079 hours
Unit receding limb, Tr	0.315 hours
Total unit time, Tb	0.394 hours

Subsection: Unit Hydrograph Summary
Label: Post A7

Return Event: 100 years
Storm Event: 100-Year

Storm Event	100-Year
Return Event	100 years
Duration	24,000 hours
Depth	8.0 in
Time of Concentration (Composite)	0.118 hours
Area (User Defined)	6,547 ft ²
<hr/>	
Computational Time Increment	0.016 hours
Time to Peak (Computed)	12.105 hours
Flow (Peak, Computed)	0.89 ft ³ /s
Output Increment	0.050 hours
Time to Flow (Peak Interpolated Output)	12.100 hours
Flow (Peak Interpolated Output)	0.89 ft ³ /s
<hr/>	
Drainage Area	
SCS CN (Composite)	85.000
Area (User Defined)	6,547 ft ²
Maximum Retention (Pervious)	1.8 in
Maximum Retention (Pervious, 20 percent)	0.4 in
<hr/>	
Cumulative Runoff	
Cumulative Runoff Depth (Pervious)	6.2 in
Runoff Volume (Pervious)	3,390 ft ³
<hr/>	
Hydrograph Volume (Area under Hydrograph curve)	
Volume	3,386 ft ³
<hr/>	
SCS Unit Hydrograph Parameters	
Time of Concentration (Composite)	0.118 hours
Computational Time Increment	0.016 hours
Unit Hydrograph Shape Factor	483.432
K Factor	0.749
Receding/Rising, Tr/Tp	1.670
Unit peak, qp	1.44 ft ³ /s
Unit peak time, Tp	0.079 hours
Unit receding limb, Tr	0.315 hours
Total unit time, Tb	0.394 hours

Subsection: Unit Hydrograph Summary
Label: Post A8

Return Event: 1 years
Storm Event: 1-Year

Storm Event	1-Year
Return Event	1 years
Duration	24,000 hours
Depth	2.9 in
Time of Concentration (Composite)	0.117 hours
Area (User Defined)	17,595 ft ²
Computational Time Increment	0.016 hours
Time to Peak (Computed)	12.106 hours
Flow (Peak, Computed)	0.84 ft ³ /s
Output Increment	0.050 hours
Time to Flow (Peak Interpolated Output)	12.100 hours
Flow (Peak Interpolated Output)	0.84 ft ³ /s
Drainage Area	
SCS CN (Composite)	93.000
Area (User Defined)	17,595 ft ²
Maximum Retention (Pervious)	0.8 in
Maximum Retention (Pervious, 20 percent)	0.2 in
Cumulative Runoff	
Cumulative Runoff Depth (Pervious)	2.2 in
Runoff Volume (Pervious)	3,165 ft ³
Hydrograph Volume (Area under Hydrograph curve)	
Volume	3,161 ft ³
SCS Unit Hydrograph Parameters	
Time of Concentration (Composite)	0.117 hours
Computational Time Increment	0.016 hours
Unit Hydrograph Shape Factor	483.432
K Factor	0.749
Receding/Rising, Tr/Tp	1.670
Unit peak, qp	3.93 ft ³ /s
Unit peak time, Tp	0.078 hours
Unit receding limb, Tr	0.311 hours
Total unit time, Tb	0.389 hours

model3.ppc
3/5/2014

Bentley PondPack V8i
(06.1.07.56)
Page 81 of 203

Bentley Systems, Inc. Headstad Methods Solution Center
27 Simon Company Drive Suite 200 W Watertown, CT
06795 USA +1-203-755-1600

Subsection: Unit Hydrograph Summary
Label: Post A8

Return Event: 10 years
Storm Event: 10-Year

Storm Event	10-Year
Return Event	10 years
Duration	24,000 hours
Depth	5.5 in
Time of Concentration (Composite)	0.117 hours
Area (User Defined)	17,595 ft ²
Computational Time Increment	0.016 hours
Time to Peak (Computed)	12.106 hours
Flow (Peak, Computed)	1.75 ft ³ /s
Output Increment	0.050 hours
Time to Flow (Peak Interpolated Output)	12.100 hours
Flow (Peak Interpolated Output)	1.75 ft ³ /s
Drainage Area	
SCS CN (Composite)	93.000
Area (User Defined)	17,595 ft ²
Maximum Retention (Pervious)	0.8 in
Maximum Retention (Pervious, 20 percent)	0.2 in
Cumulative Runoff	
Cumulative Runoff Depth (Pervious)	4.7 in
Runoff Volume (Pervious)	6,876 ft ³
Hydrograph Volume (Area under Hydrograph curve)	
Volume	6,869 ft ³
SCS Unit Hydrograph Parameters	
Time of Concentration (Composite)	0.117 hours
Computational Time Increment	0.016 hours
Unit Hydrograph Shape Factor	483.432
K Factor	0.749
Receding/Rising, Tr/Tp	1.670
Unit peak, qp	3.93 ft ³ /s
Unit peak time, Tp	0.078 hours
Unit receding limb, Tr	0.311 hours
Total unit time, Tb	0.389 hours

model3.ppc
3/5/2014

Bentley Systems, Inc. Headstad Methods Solution Center
27 Simon Company Drive Suite 200 W Watertown, CT
06795 USA +1-203-755-1600

Bentley PondPack V8i
(06.1.07.56)
Page 82 of 203

Subsection: Unit Hydrograph Summary
Label: Post A8

Return Event: 100 years
Storm Event: 100-Year

Storm Event	100-Year
Return Event	100 years
Duration	24,000 hours
Depth	8.0 in
Time of Concentration (Composite)	0.117 hours
Area (User Defined)	17,595 ft ²
Computational Time Increment	0.016 hours
Time to Peak (Computed)	12.106 hours
Flow (Peak, Computed)	2.61 ft ³ /s
Output Increment	0.050 hours
Time to Flow (Peak Interpolated Output)	12.100 hours
Flow (Peak Interpolated Output)	2.60 ft ³ /s
Drainage Area	
SCS CN (Composite)	93.000
Area (User Defined)	17,595 ft ²
Maximum Retention (Pervious)	0.8 in
Maximum Retention (Pervious, 20 percent)	0.2 in
Cumulative Runoff	
Cumulative Runoff Depth (Pervious)	7.2 in
Runoff Volume (Pervious)	10,502 ft ³
Hydrograph Volume (Area under Hydrograph curve)	
Volume	10,492 ft ³
SCS Unit Hydrograph Parameters	
Time of Concentration (Composite)	0.117 hours
Computational Time Increment	0.016 hours
Unit Hydrograph Shape Factor	483.432
K Factor	0.749
Receding/Rising, Tr/Tp	1.670
Unit peak, cp	3.93 ft ³ /s
Unit peak time, Tp	0.078 hours
Unit receding limb, Tr	0.311 hours
Total unit time, Tb	0.389 hours

Subsection: Unit Hydrograph Summary
Label: Post A9

Return Event: 1 years
Storm Event: 1-Year

Storm Event	1-Year
Return Event	1 years
Duration	24,000 hours
Depth	2.9 in
Time of Concentration (Composite)	0.083 hours
Area (User Defined)	26,986 ft ²
Computational Time Increment	0.011 hours
Time to Peak (Computed)	12.100 hours
Flow (Peak, Computed)	1.41 ft ³ /s
Output Increment	0.050 hours
Time to Flow (Peak Interpolated Output)	12.100 hours
Flow (Peak Interpolated Output)	1.41 ft ³ /s
Drainage Area	
SCS CN (Composite)	95.000
Area (User Defined)	26,986 ft ²
Maximum Retention (Pervious)	0.5 in
Maximum Retention (Pervious, 20 percent)	0.1 in
Cumulative Runoff	
Cumulative Runoff Depth (Pervious)	2.4 in
Runoff Volume (Pervious)	5,289 ft ³
Hydrograph Volume (Area under Hydrograph curve)	
Volume	5,285 ft ³
SCS Unit Hydrograph Parameters	
Time of Concentration (Composite)	0.083 hours
Computational Time Increment	0.011 hours
Unit Hydrograph Shape Factor	483.432
K Factor	0.749
Receding/Rising, Tr/Tp	1.670
Unit peak, cp	8.42 ft ³ /s
Unit peak time, Tp	0.056 hours
Unit receding limb, Tr	0.222 hours
Total unit time, Tb	0.278 hours

Subsection: Unit Hydrograph Summary
Label: Post A9

Return Event: 10 years
Storm Event: 10-Year

Storm Event	10-Year
Return Event	10 years
Duration	24,000 hours
Depth	5.5 in
Time of Concentration (Composite)	0.083 hours
Area (User Defined)	26,986 ft ²
Computational Time Increment	0.011 hours
Time to Peak (Computed)	12,100 hours
Flow (Peak, Computed)	2.80 ft ³ /s
Output Increment	0.050 hours
Time to Flow (Peak Interpolated Output)	12,100 hours
Flow (Peak Interpolated Output)	2.80 ft ³ /s
Drainage Area	
SCS CN (Composite)	95,000
Area (User Defined)	26,986 ft ²
Maximum Retention (Pervious)	0.5 in
Maximum Retention (Pervious, 20 percent)	0.1 in
Cumulative Runoff	
Cumulative Runoff Depth (Pervious)	4.9 in
Runoff Volume (Pervious)	11,053 ft ³
Hydrograph Volume (Area under Hydrograph curve)	
Volume	11,046 ft ³
SCS Unit Hydrograph Parameters	
Time of Concentration (Composite)	0.083 hours
Computational Time Increment	0.011 hours
Unit Hydrograph Shape Factor	483,432
K Factor	0.749
Receding/Rising, Tr/Tp	1.670
Unit peak qp	8.42 ft ³ /s
Unit peak time, Tp	0.056 hours
Unit receding limb, Tr	0.222 hours
Total unit time, Td	0.278 hours

Subsection: Unit Hydrograph Summary
Label: Post A9

Return Event: 100 years
Storm Event: 100-Year

Storm Event	100-Year
Return Event	100 years
Duration	24,000 hours
Depth	8.0 in
Time of Concentration (Composite)	0.083 hours
Area (User Defined)	26,986 ft ²
Computational Time Increment	0.011 hours
Time to Peak (Computed)	12,100 hours
Flow (Peak, Computed)	4.13 ft ³ /s
Output Increment	0.050 hours
Time to Flow (Peak Interpolated Output)	12,100 hours
Flow (Peak Interpolated Output)	4.13 ft ³ /s
Drainage Area	
SCS CN (Composite)	95,000
Area (User Defined)	26,986 ft ²
Maximum Retention (Pervious)	0.5 in
Maximum Retention (Pervious, 20 percent)	0.1 in
Cumulative Runoff	
Cumulative Runoff Depth (Pervious)	7.4 in
Runoff Volume (Pervious)	16,644 ft ³
Hydrograph Volume (Area under Hydrograph curve)	
Volume	16,634 ft ³
SCS Unit Hydrograph Parameters	
Time of Concentration (Composite)	0.083 hours
Computational Time Increment	0.011 hours
Unit Hydrograph Shape Factor	483,432
K Factor	0.749
Receding/Rising, Tr/Tp	1.670
Unit peak qp	8.42 ft ³ /s
Unit peak time, Tp	0.056 hours
Unit receding limb, Tr	0.222 hours
Total unit time, Td	0.278 hours

Subsection: Unit Hydrograph Summary
Label: Post B1

Return Event: 1 years
Storm Event: 1-Year

Storm Event	1-Year
Return Event	1 years
Duration	24,000 hours
Depth	2.9 in
Time of Concentration (Composite)	0.180 hours
Area (User Defined)	8,781 ft ²
Computational Time Increment	0.024 hours
Time to Peak (Computed)	12.152 hours
Flow (Peak, Computed)	0.22 ft ³ /s
Output Increment	0.050 hours
Time to Flow (Peak Interpolated Output)	12.150 hours
Flow (Peak Interpolated Output)	0.22 ft ³ /s
Drainage Area	
SCS CN (Composite)	80.000
Area (User Defined)	8,781 ft ²
Maximum Retention (Previous)	2.5 in
Maximum Retention (Previous, 20 percent)	0.5 in
Cumulative Runoff	
Cumulative Runoff Depth (Previous)	1.2 in
Runoff Volume (Previous)	860 ft ³
Hydrograph Volume (Area under Hydrograph curve)	
Volume	858 ft ³
SCS Unit Hydrograph Parameters	
Time of Concentration (Composite)	0.180 hours
Computational Time Increment	0.024 hours
Unit Hydrograph Shape Factor	483.432
K Factor	0.749
Receding/Rising, Tr/Tp	1.670
Unit peak, qp	1.27 ft ³ /s
Unit peak time, Tp	0.120 hours
Unit receding limb, Tr	0.479 hours
Total unit time, Tb	0.599 hours

Subsection: Unit Hydrograph Summary
Label: Post B1

Return Event: 10 years
Storm Event: 10-Year

Storm Event	10-Year
Return Event	10 years
Duration	24,000 hours
Depth	5.5 in
Time of Concentration (Composite)	0.180 hours
Area (User Defined)	8,781 ft ²
Computational Time Increment	0.024 hours
Time to Peak (Computed)	12.152 hours
Flow (Peak, Computed)	0.62 ft ³ /s
Output Increment	0.050 hours
Time to Flow (Peak Interpolated Output)	12.150 hours
Flow (Peak Interpolated Output)	0.62 ft ³ /s
Drainage Area	
SCS CN (Composite)	80.000
Area (User Defined)	8,781 ft ²
Maximum Retention (Previous)	2.5 in
Maximum Retention (Previous, 20 percent)	0.5 in
Cumulative Runoff	
Cumulative Runoff Depth (Previous)	3.3 in
Runoff Volume (Previous)	2,439 ft ³
Hydrograph Volume (Area under Hydrograph curve)	
Volume	2,435 ft ³
SCS Unit Hydrograph Parameters	
Time of Concentration (Composite)	0.180 hours
Computational Time Increment	0.024 hours
Unit Hydrograph Shape Factor	483.432
K Factor	0.749
Receding/Rising, Tr/Tp	1.670
Unit peak, qp	1.27 ft ³ /s
Unit peak time, Tp	0.120 hours
Unit receding limb, Tr	0.479 hours
Total unit time, Tb	0.599 hours

Subsection: Unit Hydrograph Summary
Label: Post B1

Return Event: 100 years
Storm Event: 100-Year

Storm Event	100-Year
Return Event	100 years
Duration	24,000 hours
Depth	8.0 in
Time of Concentration (Composite)	0.180 hours
Area (User Defined)	8,781 ft ²
Computational Time Increment	0.024 hours
Time to Peak (Computed)	12.128 hours
Flow (Peak, Computed)	1.04 ft ³ /s
Output Increment	0.050 hours
Time to Flow (Peak Interpolated Output)	12.150 hours
Flow (Peak Interpolated Output)	1.03 ft ³ /s
Drainage Area	
SCS CN (Composite)	80.000
Area (User Defined)	8,781 ft ²
Maximum Retention (Previous)	2.5 in
Maximum Retention (Previous, 20 percent)	0.5 in
Cumulative Runoff	
Cumulative Runoff Depth (Previous)	5.6 in
Runoff Volume (Previous)	4,116 ft ³
Hydrograph Volume (Area under Hydrograph curve)	
Volume	4,110 ft ³
SCS Unit Hydrograph Parameters	
Time of Concentration (Composite)	0.180 hours
Computational Time Increment	0.024 hours
Unit Hydrograph Shape Factor	483.432
K Factor	0.749
Receding/Rising, Tr/Tp	1.670
Unit peak, qp	1.27 ft ³ /s
Unit peak time, Tp	0.120 hours
Unit receding limb, Tr	0.475 hours
Total unit time, Tb	0.595 hours

Subsection: Unit Hydrograph Summary
Label: Post B2

Return Event: 1 years
Storm Event: 1-Year

Storm Event	1-Year
Return Event	1 years
Duration	24,000 hours
Depth	2.9 in
Time of Concentration (Composite)	0.105 hours
Area (User Defined)	12,772 ft ²
Computational Time Increment	0.014 hours
Time to Peak (Computed)	12.107 hours
Flow (Peak, Computed)	0.60 ft ³ /s
Output Increment	0.050 hours
Time to Flow (Peak Interpolated Output)	12.100 hours
Flow (Peak Interpolated Output)	0.60 ft ³ /s
Drainage Area	
SCS CN (Composite)	92.000
Area (User Defined)	12,772 ft ²
Maximum Retention (Previous)	0.9 in
Maximum Retention (Previous, 20 percent)	0.2 in
Cumulative Runoff	
Cumulative Runoff Depth (Previous)	2.1 in
Runoff Volume (Previous)	2,200 ft ³
Hydrograph Volume (Area under Hydrograph curve)	
Volume	2,198 ft ³
SCS Unit Hydrograph Parameters	
Time of Concentration (Composite)	0.105 hours
Computational Time Increment	0.014 hours
Unit Hydrograph Shape Factor	483.432
K Factor	0.749
Receding/Rising, Tr/Tp	1.670
Unit peak, qp	3.16 ft ³ /s
Unit peak time, Tp	0.070 hours
Unit receding limb, Tr	0.280 hours
Total unit time, Tb	0.350 hours

Subsection: Unit Hydrograph Summary
Label: Post B2

Return Event: 10 years
Storm Event: 10-Year

Storm Event	10-Year
Return Event	10 years
Duration	24,000 hours
Depth	5.5 in
Time of Concentration (Composite)	0.105 hours
Area (User Defined)	12,772 ft ²
<hr/>	
Computational Time Increment	0.014 hours
Time to Peak (Computed)	12.107 hours
Flow (Peak, Computed)	1.26 ft ³ /s
Output Increment	0.050 hours
Time to Flow (Peak Interpolated Output)	12.100 hours
Flow (Peak Interpolated Output)	1.26 ft ³ /s
<hr/>	
Drainage Area	
SCS CN (Composite)	92.000
Area (User Defined)	12,772 ft ²
Maximum Retention (Previous)	0.9 in
Maximum Retention (Previous, 20 percent)	0.2 in
<hr/>	
Cumulative Runoff	
Cumulative Runoff Depth (Previous)	4.6 in
Runoff Volume (Previous)	4,873 ft ³
<hr/>	
Hydrograph Volume (Area under Hydrograph curve)	
Volume	4,869 ft ³
<hr/>	
SCS Unit Hydrograph Parameters	
Time of Concentration (Composite)	0.105 hours
Computational Time Increment	0.014 hours
Unit Hydrograph Shape Factor	483.432
K Factor	0.749
Receding/Rising, Tr/Tp	1.670
Unit peak, qp	3.16 ft ³ /s
Unit peak time, Tp	0.070 hours
Unit receding limb, Tr	0.280 hours
Total unit time, Td	0.350 hours

Subsection: Unit Hydrograph Summary
Label: Post B2

Return Event: 100 years
Storm Event: 100-Year

Storm Event	100-Year
Return Event	100 years
Duration	24,000 hours
Depth	8.0 in
Time of Concentration (Composite)	0.105 hours
Area (User Defined)	12,772 ft ²
<hr/>	
Computational Time Increment	0.014 hours
Time to Peak (Computed)	12.107 hours
Flow (Peak, Computed)	1.89 ft ³ /s
Output Increment	0.050 hours
Time to Flow (Peak Interpolated Output)	12.100 hours
Flow (Peak Interpolated Output)	1.89 ft ³ /s
<hr/>	
Drainage Area	
SCS CN (Composite)	92.000
Area (User Defined)	12,772 ft ²
Maximum Retention (Previous)	0.9 in
Maximum Retention (Previous, 20 percent)	0.2 in
<hr/>	
Cumulative Runoff	
Cumulative Runoff Depth (Previous)	7.0 in
Runoff Volume (Previous)	7,497 ft ³
<hr/>	
Hydrograph Volume (Area under Hydrograph curve)	
Volume	7,491 ft ³
<hr/>	
SCS Unit Hydrograph Parameters	
Time of Concentration (Composite)	0.105 hours
Computational Time Increment	0.014 hours
Unit Hydrograph Shape Factor	483.432
K Factor	0.749
Receding/Rising, Tr/Tp	1.670
Unit peak, qp	3.16 ft ³ /s
Unit peak time, Tp	0.070 hours
Unit receding limb, Tr	0.280 hours
Total unit time, Td	0.350 hours

Subsection: Unit Hydrograph Summary
Label: Post C1

Return Event: 1 years
Storm Event: 1-Year

Storm Event	1-Year
Return Event	1 years
Duration	24,000 hours
Depth	2.9 in
Time of Concentration (Composite)	0.346 hours
Area (User Defined)	11,710 ft ²
Computational Time	
Increment	0.046 hours
Time to Peak (Computed)	12.241 hours
Flow (Peak, Computed)	0.24 ft ³ /s
Output Increment	0.050 hours
Time to Flow (Peak Interpolated Output)	12.250 hours
Flow (Peak Interpolated Output)	0.24 ft ³ /s
Drainage Area	
SCS CN (Composite)	80.000
Area (User Defined)	11,710 ft ²
Maximum Retention (Pervious)	2.5 in
Maximum Retention (Pervious, 20 percent)	0.5 in
Cumulative Runoff	
Cumulative Runoff Depth (Pervious)	1.2 in
Runoff Volume (Pervious)	1,147 ft ³
Hydrograph Volume (Area under Hydrograph curve)	
Volume	1,142 ft ³
SCS Unit Hydrograph Parameters	
Time of Concentration (Composite)	0.346 hours
Computational Time Increment	0.046 hours
Unit Hydrograph Shape Factor	483.432
K Factor	0.749
Receding/Rising, Tr/Tp	1.670
Unit peak, qp	0.88 ft ³ /s
Unit peak time, Tp	0.231 hours
Unit receding limb, Tr	0.924 hours
Total unit time, Tb	1.155 hours

Subsection: Unit Hydrograph Summary
Label: Post C1

Return Event: 10 years
Storm Event: 10-Year

Storm Event	10-Year
Return Event	10 years
Duration	24,000 hours
Depth	5.5 in
Time of Concentration (Composite)	0.346 hours
Area (User Defined)	11,710 ft ²
Computational Time	
Increment	0.046 hours
Time to Peak (Computed)	12.241 hours
Flow (Peak, Computed)	0.68 ft ³ /s
Output Increment	0.050 hours
Time to Flow (Peak Interpolated Output)	12.250 hours
Flow (Peak Interpolated Output)	0.68 ft ³ /s
Drainage Area	
SCS CN (Composite)	80.000
Area (User Defined)	11,710 ft ²
Maximum Retention (Pervious)	2.5 in
Maximum Retention (Pervious, 20 percent)	0.5 in
Cumulative Runoff	
Cumulative Runoff Depth (Pervious)	3.3 in
Runoff Volume (Pervious)	3,253 ft ³
Hydrograph Volume (Area under Hydrograph curve)	
Volume	3,242 ft ³
SCS Unit Hydrograph Parameters	
Time of Concentration (Composite)	0.346 hours
Computational Time Increment	0.046 hours
Unit Hydrograph Shape Factor	483.432
K Factor	0.749
Receding/Rising, Tr/Tp	1.670
Unit peak, qp	0.88 ft ³ /s
Unit peak time, Tp	0.231 hours
Unit receding limb, Tr	0.924 hours
Total unit time, Tb	1.155 hours

Subsection: Unit Hydrograph Summary
Label: Post C1

Return Event: 100 years
Storm Event: 100-Year

Storm Event	100-Year
Return Event	100 years
Duration	24,000 hours
Depth	8.0 in
Time of Concentration (Composite)	0.346 hours
Area (User Defined)	11,710 ft ²
Computational Time Increment	0.046 hours
Time to Peak (Computed)	12.241 hours
Flow (Peak, Computed)	1.14 ft ³ /s
Output Increment	0.050 hours
Time to Flow (Peak Interpolated Output)	12.250 hours
Flow (Peak Interpolated Output)	1.13 ft ³ /s
Drainage Area	
SCS CN (Composite)	80.000
Area (User Defined)	11,710 ft ²
Maximum Retention (Pervious)	2.5 in
Maximum Retention (Pervious, 20 percent)	0.5 in
Cumulative Runoff	
Cumulative Runoff Depth (Pervious)	5.6 in
Runoff Volume (Pervious)	5,489 ft ³
Hydrograph Volume (Area under Hydrograph curve)	
Volume	5,473 ft ³
SCS Unit Hydrograph Parameters	
Time of Concentration (Composite)	0.346 hours
Computational Time Increment	0.046 hours
Unit Hydrograph Shape Factor	483.432
K Factor	0.749
Receding/Rising, Tr/Tp	1.670
Unit peak, qp	0.88 ft ³ /s
Unit peak time, Tp	0.231 hours
Unit receding limb, Tr	0.924 hours
Total unit time, Tb	1.155 hours

Subsection: Unit Hydrograph Summary
Label: Post C2

Return Event: 1 years
Storm Event: 1-Year

Storm Event	1-Year
Return Event	1 years
Duration	24,000 hours
Depth	2.9 in
Time of Concentration (Composite)	0.110 hours
Area (User Defined)	52,427 ft ²
Computational Time Increment	0.015 hours
Time to Peak (Computed)	12.116 hours
Flow (Peak, Computed)	2.53 ft ³ /s
Output Increment	0.050 hours
Time to Flow (Peak Interpolated Output)	12.100 hours
Flow (Peak Interpolated Output)	2.53 ft ³ /s
Drainage Area	
SCS CN (Composite)	93.000
Area (User Defined)	52,427 ft ²
Maximum Retention (Pervious)	0.8 in
Maximum Retention (Pervious, 20 percent)	0.2 in
Cumulative Runoff	
Cumulative Runoff Depth (Pervious)	2.2 in
Runoff Volume (Pervious)	9,430 ft ³
Hydrograph Volume (Area under Hydrograph curve)	
Volume	9,422 ft ³
SCS Unit Hydrograph Parameters	
Time of Concentration (Composite)	0.110 hours
Computational Time Increment	0.015 hours
Unit Hydrograph Shape Factor	483.432
K Factor	0.749
Receding/Rising, Tr/Tp	1.670
Unit peak, qp	12.40 ft ³ /s
Unit peak time, Tp	0.072 hours
Unit receding limb, Tr	0.293 hours
Total unit time, Tb	0.367 hours

Subsection: Unit Hydrograph Summary
Label: Post C2

Return Event: 10 years
Storm Event: 10-Year

Storm Event	10-Year
Return Event	10 years
Duration	24,000 hours
Depth	5.5 in
Time of Concentration (Composite)	0.110 hours
Area (User Defined)	52,427 ft ²
<hr/>	
Computational Time Increment	0.015 hours
Time to Peak (Computed)	12.101 hours
Flow (Peak, Computed)	5.25 ft ³ /s
Output Increment	0.050 hours
Time to Flow (Peak Interpolated Output)	12.100 hours
Flow (Peak Interpolated Output)	5.24 ft ³ /s
<hr/>	
Drainage Area	
SCS CN (Composite)	93.000
Area (User Defined)	52,427 ft ²
Maximum Retention (Previous)	0.8 in
Maximum Retention (Previous, 20 percent)	0.2 in
<hr/>	
Cumulative Runoff	
Cumulative Runoff Depth (Previous)	4.7 in
Runoff Volume (Previous)	20,489 ft ³
<hr/>	
Hydrograph Volume (Area under Hydrograph curve)	
Volume	20,472 ft ³
<hr/>	
SCS Unit Hydrograph Parameters	
Time of Concentration (Composite)	0.110 hours
Computational Time Increment	0.015 hours
Unit Hydrograph Shape Factor	483.432
K Factor	0.749
Receding/Rising, Tr/Tp	1.670
Unit peak qp	12.40 ft ³ /s
Unit peak time, Tp	0.072 hours
Unit receding limb, Tr	0.293 hours
Total unit time, Td	0.357 hours

Subsection: Unit Hydrograph Summary
Label: Post C2

Return Event: 100 years
Storm Event: 100-Year

Storm Event	100-Year
Return Event	100 years
Duration	24,000 hours
Depth	8.0 in
Time of Concentration (Composite)	0.110 hours
Area (User Defined)	52,427 ft ²
<hr/>	
Computational Time Increment	0.015 hours
Time to Peak (Computed)	12.101 hours
Flow (Peak, Computed)	7.81 ft ³ /s
Output Increment	0.050 hours
Time to Flow (Peak Interpolated Output)	12.100 hours
Flow (Peak Interpolated Output)	7.81 ft ³ /s
<hr/>	
Drainage Area	
SCS CN (Composite)	93.000
Area (User Defined)	52,427 ft ²
Maximum Retention (Previous)	0.8 in
Maximum Retention (Previous, 20 percent)	0.2 in
<hr/>	
Cumulative Runoff	
Cumulative Runoff Depth (Previous)	7.2 in
Runoff Volume (Previous)	31,293 ft ³
<hr/>	
Hydrograph Volume (Area under Hydrograph curve)	
Volume	31,269 ft ³
<hr/>	
SCS Unit Hydrograph Parameters	
Time of Concentration (Composite)	0.110 hours
Computational Time Increment	0.015 hours
Unit Hydrograph Shape Factor	483.432
K Factor	0.749
Receding/Rising, Tr/Tp	1.670
Unit peak qp	12.40 ft ³ /s
Unit peak time, Tp	0.072 hours
Unit receding limb, Tr	0.293 hours
Total unit time, Td	0.357 hours

Subsection: Unit Hydrograph Summary
Label: Pre A

Return Event: 1 years
Storm Event: 1-Year

Storm Event	1-Year
Return Event	1 years
Duration	24,000 hours
Depth	2.9 in
Time of Concentration (Composite)	0.469 hours
Area (User Defined)	300,636 ft ²
Computational Time Increment	0.063 hours
Time to Peak (Computed)	12.315 hours
Flow (Peak, Computed)	6.97 ft ³ /s
Output Increment	0.050 hours
Time to Flow (Peak Interpolated Output)	12.350 hours
Flow (Peak Interpolated Output)	6.94 ft ³ /s
Drainage Area	
SCS CN (Composite)	85.000
Area (User Defined)	300,636 ft ²
Maximum Retention (Pervious)	1.8 in
Maximum Retention (Pervious, 20 percent)	0.4 in
Cumulative Runoff	
Cumulative Runoff Depth (Pervious)	1.5 in
Runoff Volume (Pervious)	37,695 ft ³
Hydrograph Volume (Area under Hydrograph curve)	
Volume	37,498 ft ³
SCS Unit Hydrograph Parameters	
Time of Concentration (Composite)	0.469 hours
Computational Time Increment	0.063 hours
Unit Hydrograph Shape Factor	483.432
K Factor	0.749
Receding/Rising, Tr/Tp	1.670
Unit peak, qp	16.68 ft ³ /s
Unit peak time, Tp	0.313 hours
Unit receding limb, Tr	1.250 hours
Total unit time, Tb	1.563 hours

Subsection: Unit Hydrograph Summary
Label: Pre A

Return Event: 10 years
Storm Event: 10-Year

Storm Event	10-Year
Return Event	10 years
Duration	24,000 hours
Depth	5.5 in
Time of Concentration (Composite)	0.469 hours
Area (User Defined)	300,636 ft ²
Computational Time Increment	0.063 hours
Time to Peak (Computed)	12.315 hours
Flow (Peak, Computed)	17.64 ft ³ /s
Output Increment	0.050 hours
Time to Flow (Peak Interpolated Output)	12.300 hours
Flow (Peak Interpolated Output)	17.48 ft ³ /s
Drainage Area	
SCS CN (Composite)	85.000
Area (User Defined)	300,636 ft ²
Maximum Retention (Pervious)	1.8 in
Maximum Retention (Pervious, 20 percent)	0.4 in
Cumulative Runoff	
Cumulative Runoff Depth (Pervious)	3.8 in
Runoff Volume (Pervious)	96,026 ft ³
Hydrograph Volume (Area under Hydrograph curve)	
Volume	95,605 ft ³
SCS Unit Hydrograph Parameters	
Time of Concentration (Composite)	0.469 hours
Computational Time Increment	0.063 hours
Unit Hydrograph Shape Factor	483.432
K Factor	0.749
Receding/Rising, Tr/Tp	1.670
Unit peak, qp	16.68 ft ³ /s
Unit peak time, Tp	0.313 hours
Unit receding limb, Tr	1.250 hours
Total unit time, Tb	1.563 hours

Subsection: Unit Hydrograph Summary
Label: Pre A

Return Event: 100 years
Storm Event: 100-Year

Storm Event	100-Year
Return Event	100 years
Duration	24,000 hours
Depth	8.0 in
Time of Concentration (Composite)	0.469 hours
Area (User Defined)	300,656 ft ²
Computational Time Increment	0.063 hours
Time to Peak (Computed)	12.315 hours
Flow (Peak, Computed)	28.07 ft ³ /s
Output Increment	0.050 hours
Time to Flow (Peak Interpolated Output)	12.300 hours
Flow (Peak Interpolated Output)	27.85 ft ³ /s
Drainage Area	
SCS CN (Composite)	85.000
Area (User Defined)	300,656 ft ²
Maximum Retention (Previous)	1.8 in
Maximum Retention (Previous, 20 percent)	0.4 in
Cumulative Runoff	
Cumulative Runoff Depth (Previous)	6.2 in
Runoff Volume (Previous)	155,660 ft ³
Hydrograph Volume (Area under Hydrograph curve)	
Volume	155,028 ft ³
SCS Unit Hydrograph Parameters	
Time of Concentration (Composite)	0.469 hours
Computational Time Increment	0.063 hours
Unit Hydrograph Shape Factor	483.432
K Factor	0.749
Receding/Rising, Tr/Tp	1.670
Unit peak, qp	16.68 ft ³ /s
Unit peak time, Tp	0.312 hours
Unit receding limb, Tr	1.250 hours
Total unit time, Tb	1.563 hours

Subsection: Unit Hydrograph Summary
Label: Pre B

Return Event: 1 years
Storm Event: 1-Year

Storm Event	1-Year
Return Event	1 years
Duration	24,000 hours
Depth	2.9 in
Time of Concentration (Composite)	0.265 hours
Area (User Defined)	35,886 ft ²
Computational Time Increment	0.035 hours
Time to Peak (Computed)	12.211 hours
Flow (Peak, Computed)	0.94 ft ³ /s
Output Increment	0.050 hours
Time to Flow (Peak Interpolated Output)	12.200 hours
Flow (Peak Interpolated Output)	0.93 ft ³ /s
Drainage Area	
SCS CN (Composite)	83.000
Area (User Defined)	35,886 ft ²
Maximum Retention (Previous)	2.0 in
Maximum Retention (Previous, 20 percent)	0.4 in
Cumulative Runoff	
Cumulative Runoff Depth (Previous)	1.4 in
Runoff Volume (Previous)	4,086 ft ³
Hydrograph Volume (Area under Hydrograph curve)	
Volume	4,074 ft ³
SCS Unit Hydrograph Parameters	
Time of Concentration (Composite)	0.265 hours
Computational Time Increment	0.035 hours
Unit Hydrograph Shape Factor	483.432
K Factor	0.749
Receding/Rising, Tr/Tp	1.670
Unit peak, qp	3.52 ft ³ /s
Unit peak time, Tp	0.177 hours
Unit receding limb, Tr	0.708 hours
Total unit time, Tb	0.885 hours

Subsection: Unit Hydrograph Summary
Label: Pre B

Return Event: 10 years
Storm Event: 10-Year

Storm Event	10-Year
Return Event	10 years
Duration	24,000 hours
Depth	5.5 in
Time of Concentration (Composite)	0.265 hours
Area (User Defined)	35,886 ft ²
Computational Time	
Increment	0.035 hours
Time to Peak (Computed)	12.175 hours
Flow (Peak, Computed)	2.46 ft ³ /s
Output Increment	0.050 hours
Time to Flow (Peak Interpolated Output)	12.200 hours
Flow (Peak Interpolated Output)	2.47 ft ³ /s
Drainage Area	
SCS CN (Composite)	83.000
Area (User Defined)	35,886 ft ²
Maximum Retention (Pervious)	2.0 in
Maximum Retention (Pervious, 20 percent)	0.4 in
Cumulative Runoff	
Cumulative Runoff Depth (Pervious)	3.5 in
Runoff Volume (Pervious)	10,855 ft ³
Hydrograph Volume (Area under Hydrograph curve)	
Volume	10,827 ft ³
SCS Unit Hydrograph Parameters	
Time of Concentration (Composite)	0.265 hours
Computational Time Increment	0.035 hours
Unit Hydrograph Shape Factor	483.432
K Factor	0.749
Receding/Rising, Tr/Tp	1.670
Unit peak, qp	3.52 ft ³ /s
Unit peak time, Tp	0.177 hours
Unit receding limb, Tr	0.708 hours
Total unit time, Tb	0.885 hours

Subsection: Unit Hydrograph Summary
Label: Pre B

Return Event: 100 years
Storm Event: 100-Year

Storm Event	100-Year
Return Event	100 years
Duration	24,000 hours
Depth	8.0 in
Time of Concentration (Composite)	0.265 hours
Area (User Defined)	35,886 ft ²
Computational Time	
Increment	0.035 hours
Time to Peak (Computed)	12.175 hours
Flow (Peak, Computed)	4.02 ft ³ /s
Output Increment	0.050 hours
Time to Flow (Peak Interpolated Output)	12.200 hours
Flow (Peak Interpolated Output)	3.99 ft ³ /s
Drainage Area	
SCS CN (Composite)	83.000
Area (User Defined)	35,886 ft ²
Maximum Retention (Pervious)	2.0 in
Maximum Retention (Pervious, 20 percent)	0.4 in
Cumulative Runoff	
Cumulative Runoff Depth (Pervious)	6.0 in
Runoff Volume (Pervious)	17,875 ft ³
Hydrograph Volume (Area under Hydrograph curve)	
Volume	17,832 ft ³
SCS Unit Hydrograph Parameters	
Time of Concentration (Composite)	0.265 hours
Computational Time Increment	0.035 hours
Unit Hydrograph Shape Factor	483.432
K Factor	0.749
Receding/Rising, Tr/Tp	1.670
Unit peak, qp	3.52 ft ³ /s
Unit peak time, Tp	0.177 hours
Unit receding limb, Tr	0.708 hours
Total unit time, Tb	0.885 hours

Subsection: Unit Hydrograph Summary
Label: Pre C

Return Event: 1 years
Storm Event: 1-Year

Storm Event	1-Year
Return Event	1 years
Duration	24,000 hours
Depth	2.9 in
Time of Concentration (Composite)	0.360 hours
Area (User Defined)	72,449 ft ²
Computational Time Increment	0.048 hours
Time to Peak (Computed)	12.277 hours
Flow (Peak, Computed)	1.95 ft ³ /s
Output Increment	0.050 hours
Time to Flow (Peak Interpolated Output)	12.250 hours
Flow (Peak Interpolated Output)	1.95 ft ³ /s
Drainage Area	
SCS CN (Composite)	86.000
Area (User Defined)	72,449 ft ²
Maximum Retention (Pervious)	1.6 in
Maximum Retention (Pervious, 20 percent)	0.3 in
Cumulative Runoff	
Cumulative Runoff Depth (Pervious)	1.6 in
Runoff Volume (Pervious)	9,522 ft ³
Hydrograph Volume (Area under Hydrograph curve)	
Volume	9,480 ft ³
SCS Unit Hydrograph Parameters	
Time of Concentration (Composite)	0.360 hours
Computational Time Increment	0.048 hours
Unit Hydrograph Shape Factor	483.432
K Factor	0.749
Receding/Rising, Tr/Tp	1.670
Unit peak, qp	5.24 ft ³ /s
Unit peak time, Tp	0.240 hours
Unit receding limb, Tr	0.959 hours
Total unit time, Tb	1.199 hours

Subsection: Unit Hydrograph Summary
Label: Pre C

Return Event: 10 years
Storm Event: 10-Year

Storm Event	10-Year
Return Event	10 years
Duration	24,000 hours
Depth	5.5 in
Time of Concentration (Composite)	0.360 hours
Area (User Defined)	72,449 ft ²
Computational Time Increment	0.048 hours
Time to Peak (Computed)	12.228 hours
Flow (Peak, Computed)	4.83 ft ³ /s
Output Increment	0.050 hours
Time to Flow (Peak Interpolated Output)	12.250 hours
Flow (Peak Interpolated Output)	4.81 ft ³ /s
Drainage Area	
SCS CN (Composite)	86.000
Area (User Defined)	72,449 ft ²
Maximum Retention (Pervious)	1.6 in
Maximum Retention (Pervious, 20 percent)	0.3 in
Cumulative Runoff	
Cumulative Runoff Depth (Pervious)	3.9 in
Runoff Volume (Pervious)	22,764 ft ³
Hydrograph Volume (Area under Hydrograph curve)	
Volume	23,675 ft ³
SCS Unit Hydrograph Parameters	
Time of Concentration (Composite)	0.360 hours
Computational Time Increment	0.048 hours
Unit Hydrograph Shape Factor	483.432
K Factor	0.749
Receding/Rising, Tr/Tp	1.670
Unit peak, qp	5.24 ft ³ /s
Unit peak time, Tp	0.240 hours
Unit receding limb, Tr	0.959 hours
Total unit time, Tb	1.199 hours

Subsection: Unit Hydrograph Summary
Label: Pre C

Return Event: 100 years
Storm Event: 100-Year

Storm Event	100-Year
Return Event	100 years
Duration	24,000 hours
Depth	8.0 in
Time of Concentration (Composite)	0.360 hours
Area (User Defined)	72,449 ft ²
Computational Time Increment	0.048 hours
Time to Peak (Computed)	12,229 hours
Flow (Peak, Computed)	7.62 ft ³ /s
Output Increment	0.050 hours
Time to Flow (Peak Interpolated Output)	12,250 hours
Flow (Peak Interpolated Output)	7.58 ft ³ /s
Drainage Area	
SCS CN (Composite)	86.000
Area (User Defined)	72,449 ft ²
Maximum Retention (Pervious)	1.6 in
Maximum Retention (Pervious, 20 percent)	0.3 in
Cumulative Runoff	
Cumulative Runoff Depth (Pervious)	6.3 in
Runoff Volume (Pervious)	38,225 ft ³
Hydrograph Volume (Area under Hydrograph curve)	
Volume	38,092 ft ³
SCS Unit Hydrograph Parameters	
Time of Concentration (Composite)	0.360 hours
Computational Time Increment	0.048 hours
Unit Hydrograph Shape Factor	483.432
K Factor	0.749
Receding/Rising, Tr/Tp	1.670
Unit peak, qp	5.24 ft ³ /s
Unit peak time, Tp	0.240 hours
Unit receding limb, Tr	0.959 hours
Total unit time, Td	1.199 hours

model3.pps
3/5/2014

Bentley Systems, Inc. Headquarters Solution Center
27 Simon Company Drive Suite 200 W. Watertown, CT
06795 USA +1-203-755-1666

Bentley PondPack V8i
[05.11.01.50]
Page 107 of 203

Subsection: Elevation-Area Volume Curve
Label: Blo 1

Return Event: 1 years
Storm Event: 1-Year

Elevation (ft)	Planimeter (ft ²)	Area (ft ²)	A1+A2+qcr (ft ²)	Volume (ft ³)	Volume (Total) (ft ³)
349.00	0.0	530	0	0	0
351.50	0.0	530	1,590	1,537	1,537
352.00	0.0	2,650	4,365	1,446	1,683
353.00	0.0	3,600	9,339	3,113	4,795

model3.pps
3/5/2014

Bentley Systems, Inc. Headquarters Solution Center
27 Simon Company Drive Suite 200 W. Watertown, CT
06795 USA +1-203-755-1666

Bentley PondPack V8i
[05.11.01.50]
Page 108 of 203

Subsection: Elevation-Area Volume Curve
 Label: Blo 2

Return Event: 1 years
 Storm Event: 1-Year

Elevation (ft)	Planimeter (ft ²)	Area (ft ²)	$A1+A2+sqr(A1*A2)$ (ft ²)	Volume (ft ³)	Volume (Total) (ft ³)
351.25	0.0	132	0	0	0
354.15	0.0	122	396	383	383
354.25	0.0	660	1,087	36	419
355.25	0.0	1,120	2,640	880	1,299

Elevation (ft)	Planimeter (ft ²)	Area (ft ²)	$A1+A2+sqr(A1*A2)$ (ft ²)	Volume (ft ³)	Volume (Total) (ft ³)
352.00	0.0	146	0	0	0
354.90	0.0	146	438	423	423
355.00	0.0	730	1,202	40	463
356.00	0.0	2,130	4,107	1,369	1,832

Subsection: Elevation-Area Volume Curve
 Label: Blo 4

Return Event: 1 years
 Storm Event: 1-Year

Elevation (ft)	Planimeter (ft ²)	Area (ft ²)	A1+A2+str (ft ²)	Volume (ft ³)	Volume (Total) (ft ³)
351.00	0.0	150	0	0	0
353.50	0.0	150	450	435	435
354.00	0.0	740	1,223	41	476
355.00	0.0	2,300	4,345	1,448	1,924

Subsection: Elevation-Area Volume Curve
 Label: Blo 5

Return Event: 1 years
 Storm Event: 1-Year

Elevation (ft)	Planimeter (ft ²)	Area (ft ²)	A1+A2+str (ft ²)	Volume (ft ³)	Volume (Total) (ft ³)
350.33	0.0	154	0	0	0
353.23	0.0	154	462	447	447
353.33	0.0	770	1,268	42	489
354.33	0.0	2,300	4,401	1,467	1,956

Subsection: Elevation-Area Volume Curve
 Label: Blo 6

Subsection: Elevation-Area Volume Curve
 Label: PP 1,5

Return Event: 1 years
 Storm Event: 1-Year

Elevation (ft)	Perimeter (ft²)	Area (ft²)	A1+A2+sq (ft²)	Volume (ft³)	Volume (Total) (ft³)
348.50	0.0	203	0	0	0
351.46	0.0	203	609	589	589
351.50	0.0	1,016	1,673	56	644
352.50	0.0	2,134	4,522	1,541	2,185

Elevation (ft)	Perimeter (ft²)	Area (ft²)	A1+A2+sq (ft²)	Volume (ft³)	Volume (Total) (ft³)
348.72	0.0	1,962	0	0	0
351.72	0.0	1,962	5,886	5,886	5,886
352.72	0.0	4,995	9,969	3,323	9,209
353.22	0.0	4,995	14,715	2,452	11,662

Subsection: Elevation-Area Volume Curve
 Label: PP 2,2,4

Subsection: Elevation-Area Volume Curve
 Label: Revised Pond

Return Event: 1 years
 Storm Event: 1-Year

Elevation (ft)	Perimeter (ft)	Area (ft ²)	$A1+A2+sqr(A1*A2)$ (ft ²)	Volume (ft ³)	Volume (Total) (ft ³)
348.60	0.0	4,147	0	0	0
351.60	0.0	4,167	12,441	12,441	12,441
352.60	0.0	10,368	21,072	7,024	19,465
353.10	0.0	10,368	31,104	5,184	24,649

Elevation (ft)	Perimeter (ft)	Area (ft ²)	$A1+A2+sqr(A1*A2)$ (ft ²)	Volume (ft ³)	Volume (Total) (ft ³)
337.00	0.0	1,369	0	0	0
339.00	0.0	2,530	5,760	3,840	3,840
341.00	0.0	6,280	12,796	8,531	12,371
343.00	0.0	9,596	23,639	15,759	28,130
345.00	0.0	13,062	33,854	22,569	50,699
347.00	0.0	15,744	44,595	29,730	80,429

Subsection: Outlet Input Data
Label: Blo 1

Return Event: 1 years
Storm Event: 1-Year

Requested Pond Water Surface Elevations	
Minimum (Headwater)	349.00 ft
Increment (Headwater)	0.50 ft
Maximum (Headwater)	353.00 ft

Outlet Connectivity

Structure Type	Outlet ID	Direction	Outlet	E1 (ft)	E2 (ft)
Inlet Box	Riser	Forward	Culvert	352.50	353.00
User Defined Table	Defined Raising Table	Forward	Culvert	0.00	353.00
Culvert-Circular Tailwater-Settings	Culvert Tailwater	Forward	TW	350.13 (N/A)	353.00 (N/A)

Subsection: Outlet Input Data
Label: Blo 1

Return Event: 1 years
Storm Event: 1-Year

Structure ID: User Defined Raising Table
Structure Type: User Defined Table

Elevation (ft)	Flow (ft ³ /s)
0.00	0.05
2.00	0.05
4.00	0.05

Structure ID: Riser
Structure Type: Inlet Box

Number of Openings: 1

Elevation: 352.50 ft

Orifice Area: 16.0 ft²

Orifice Coefficient: 0.600

Weir Length: 16.00 ft

Weir Coefficient: 3.00 (ft^{0.5})/s

K Reverse: 1.000

Manning's n: 0.000

Key, Charged Riser: 0.000

Weir Submergence: False

Orifice H to crest: False

Structure ID: Culvert
Structure Type: Culvert-Circular

Number of Barrels: 1

Diameter: 15.0 in

Length: 258.00 ft

Length (Computed Barrel): 258.16 ft

Slope (Computed): 0.035 ft/ft

Outlet Control Data

Manning's n: 0.013

Kc: 0.200

Kb: 0.023

Kr: 0.000

Convergence Tolerances: 0.00 ft

Inlet Control Data

Equation Form: Form 1

K: 0.0045

M: 2.0000

C: 0.0317

Y: 0.6900

T1 ratio (HW/D): 1.078

T2 ratio (HW/D): 1.180

Slope Correction Factor: -0.500

Subsection: Outlet Input Data
Label: Blo 1

Return Event: 1 years
Storm Event: 1-Year

Requested Pond Water Surface Elevations	
Minimum (Headwater)	349.00 ft
Increment (Headwater)	0.50 ft
Maximum (Headwater)	353.00 ft

Outlet Connectivity

Structure Type	Outlet ID	Direction	Outlet	E1 (ft)	E2 (ft)
Inlet Box	Riser	Forward	Culvert	352.50	353.00
User Defined Table	Defined Raising Table	Forward	Culvert	0.00	353.00
Culvert-Circular Tailwater-Settings	Culvert Tailwater	Forward	TW	350.13 (N/A)	353.00 (N/A)

Subsection: Outlet Input Data
Label: B1c 1

Return Event: 1 years
Storm Event: 1-Year

Use unsubmerged inlet control 0 equation below T1 elevation.
Use submerged inlet control 0 equation above T2 elevation

In transition zone between unsubmerged and submerged inlet control, interpolate between flows at T1 & T2...

	T1 Elevation	T2 Elevation	T1 Flow	T2 Flow
	351.48 ft	351.60 ft	4.80 ft ³ /s	5.49 ft ³ /s

Subsection: Outlet Input Data
Label: B1c 1

Return Event: 1 years
Storm Event: 1-Year

Structure ID: TW	Structure Type: TW Setup, DS Channel
Tailwater Type:	Free Outfall
Convergence Tolerances	
Maximum Iterations	30
Tailwater Tolerance (Minimum)	0.01 ft
Tailwater Tolerance (Maximum)	0.50 ft
Headwater Tolerance (Minimum)	0.01 ft
Headwater Tolerance (Maximum)	0.50 ft
Flow Tolerance (Minimum)	0.001 ft ³ /s
Flow Tolerance (Maximum)	10.000 ft ³ /s

Subsection: Individual Outlet Curves
 Label: Bio 1

Return Event: 1 years
 Storm Event: 1-Year

RATING TABLE FOR ONE OUTLET TYPE
 Structure ID = Riser (Inlet Box)

Upstream ID = (Pond Water Surface)
 Downstream ID = Culvert (Culvert-Circular)

Water Surface Elevation (ft)	Device Flow (ft ³ /s)	(into) Headwater Hydraulic Grade Line (ft)	Converge Downstream Hydraulic Grade Line (ft)	Next Downstream Hydraulic Grade Line (ft)	Downstream Hydraulic Grade Line Error (ft)	Convergence Error (ft/s)	Downstream Channel Tailwater (ft)	Tailwater Error (ft)
349.00	0.00	0.00	0.00	0.00	0.00	0.00	(N/A)	0.00
349.50	0.00	0.00	0.00	0.00	0.00	0.00	(N/A)	0.00
350.00	0.00	0.00	0.00	0.00	0.00	0.00	(N/A)	0.00
350.13	0.00	0.00	0.00	0.00	0.00	0.00	(N/A)	0.00
350.50	0.00	0.00	0.00	0.00	0.00	0.00	(N/A)	0.00
351.00	0.00	0.00	0.00	0.00	0.00	0.00	(N/A)	0.00
351.50	0.00	0.00	0.00	0.00	0.00	0.00	(N/A)	0.00
352.00	0.00	0.00	0.00	0.00	0.00	0.00	(N/A)	0.00
352.50	0.00	0.00	0.00	0.00	0.00	0.00	(N/A)	0.00
353.00	16.97	353.00	353.00	353.00	0.00	0.00	(N/A)	0.00

Message
 WS below an invert; no flow.
 WS below an invert; no flow.
 WS below an invert; no flow.
 WS below an invert; no flow.
 WS below an invert; no flow.
 WS below an invert; no flow.
 WS below an invert; no flow.
 WS below an invert; no flow.
 FULLY CHARGED RISER: ADJUSTED TO WEIR: H =0.5ft

Subsection: Individual Outlet Curves
 Label: Bio 1

Return Event: 1 years
 Storm Event: 1-Year

RATING TABLE FOR ONE OUTLET TYPE
 Structure ID = User Defined Rating Table (User Defined Table)

Upstream ID = (Pond Water Surface)
 Downstream ID = Culvert (Culvert-Circular)

Water Surface Elevation (ft)	Device Flow (ft ³ /s)	(into) Headwater Hydraulic Grade Line (ft)	Converge Downstream Hydraulic Grade Line (ft)	Next Downstream Hydraulic Grade Line (ft)	Downstream Hydraulic Grade Line Error (ft)	Convergence Error (ft/s)	Downstream Channel Tailwater (ft)	Tailwater Error (ft)
349.00	0.00	0.00	0.00	0.00	0.00	0.00	(N/A)	0.00
349.50	0.00	0.00	0.00	0.00	0.00	0.00	(N/A)	0.00
350.00	0.00	0.00	0.00	0.00	0.00	0.00	(N/A)	0.00
350.13	0.00	0.00	0.00	0.00	0.00	0.00	(N/A)	0.00
350.50	0.05	350.50	350.25	350.25	0.00	0.00	(N/A)	0.00
351.00	0.05	351.00	350.25	350.25	0.00	0.00	(N/A)	0.00
351.50	0.05	351.50	350.25	350.25	0.00	0.00	(N/A)	0.00
352.00	0.05	352.00	350.25	350.25	0.00	0.00	(N/A)	0.00
352.50	0.05	352.50	350.25	350.25	0.00	0.00	(N/A)	0.00
353.00	0.05	353.00	353.00	353.00	0.00	0.00	(N/A)	0.00

Message
 WS below an invert; no flow.
 WS below an invert; no flow.
 WS below an invert; no flow.
 WS below an invert; no flow.
 Interpolated from input table
 Interpolated from input table
 Interpolated from input table

Subsection: Individual Outlet Curves
Label: B10 1

Return Event: 1 years
Storm Event: 1-Year

RATING TABLE FOR ONE OUTLET TYPE
Structure ID = Culvert (Culvert-Circular)

Manning's open channel maximum capacity: 13.07 ft³/s
Upstream ID = Riser, User Defined Rating Table
Downstream ID = Tailwater (Pond Outfall)

Water Surface Elevation (ft)	Flow (ft ³ /s)	Device	Converge		Downstream		Next		Downstream		Convergence		Downstream		Tailwater	
			Hydraulic Grade Line	Hydraulic Grade Line	Hydraulic Grade Line	Hydraulic Grade Line	Hydraulic Grade Line Error	Hydraulic Grade Line Error	Channel Tailwater	Error	Error	Error	Tailwater	Error		
349.00	0.00		0.00	0.00	Free Outfall	0.00	0.00	0.00	0.00	0.00	0.00	0.00	(N/A)	0.00	0.00	0.00
349.50	0.00		0.00	0.00	Free Outfall	0.00	0.00	0.00	0.00	0.00	0.00	0.00	(N/A)	0.00	0.00	0.00
350.00	0.00		0.00	0.00	Free Outfall	0.00	0.00	0.00	0.00	0.00	0.00	0.00	(N/A)	0.00	0.00	0.00
350.13	0.00		0.00	0.00	Free Outfall	0.00	0.00	0.00	0.00	0.00	0.00	0.00	(N/A)	0.00	0.00	0.00
350.50	0.05		350.25	0.05	Free Outfall	0.00	0.00	0.00	0.00	0.00	0.00	0.00	(N/A)	0.00	0.00	0.00
351.00	0.05		350.25	0.05	Free Outfall	0.00	0.00	0.00	0.00	0.00	0.00	0.00	(N/A)	0.00	0.00	0.00
351.50	0.05		350.25	0.05	Free Outfall	0.00	0.00	0.00	0.00	0.00	0.00	0.00	(N/A)	0.00	0.00	0.00
352.00	0.05		350.25	0.05	Free Outfall	0.00	0.00	0.00	0.00	0.00	0.00	0.00	(N/A)	0.00	0.00	0.00
352.50	0.05		350.25	0.05	Free Outfall	0.00	0.00	0.00	0.00	0.00	0.00	0.00	(N/A)	0.00	0.00	0.00
353.00	9.82		353.00	9.82	Free Outfall	0.00	0.00	7.20	0.00	0.00	7.20	0.00	(N/A)	0.00	0.00	0.00

Message

WS below an invert; no flow.
WS below an invert; no flow.
WS below an invert; no flow.
WS below an invert; no flow.
WS below an invert; no flow.
CRIT-DEPTH CONTROL Vh = .029ft
Dcr = .085ft CRIT-DEPTH Hey = .00ft
CRIT-DEPTH CONTROL Vh = .029ft
Dcr = .085ft CRIT-DEPTH Hey = .00ft
CRIT-DEPTH CONTROL Vh = .029ft
Dcr = .085ft CRIT-DEPTH Hey = .00ft
CRIT-DEPTH CONTROL Vh = .029ft
Dcr = .085ft CRIT-DEPTH Hey = .00ft
CRIT-DEPTH CONTROL Vh = .029ft
Dcr = .085ft CRIT-DEPTH Hey = .00ft
INLET CONTROL... Submerged: HW = 2.87

model3.ppc
3/5/2014

Bentley Systems, Inc. Headbad Methods Solution Center
27 Siemon Company Drive Suite 200 W. Waterdown, CT
06795 USA +1-203-755-1686

Bentley PondPack V8i
[06.11.01.50]
Page 123 of 203

Subsection: Composite Rating Curve
Label: B10 1

Return Event: 1 years
Storm Event: 1-Year

Composite Outflow Summary

Water Surface Elevation (ft)	Flow (ft ³ /s)	Tailwater Elevation (ft)	Convergence Error (ft)
349.00	0.00	(N/A)	0.00
349.50	0.00	(N/A)	0.00
350.00	0.00	(N/A)	0.00
350.13	0.00	(N/A)	0.00
350.50	0.05	(N/A)	0.00
351.00	0.05	(N/A)	0.00
351.50	0.05	(N/A)	0.00
352.00	0.05	(N/A)	0.00
352.50	0.05	(N/A)	0.00
353.00	9.82	(N/A)	0.00

Contributing Structures

(no Q): Riser, User Defined Rating Table, Culvert
(no Q): Riser, User Defined Rating Table, Culvert
(no Q): Riser, User Defined Rating Table, Culvert
(no Q): Riser, User Defined Rating Table, Culvert
(no Q): Riser, User Defined Rating Table, Culvert
(no Q): Riser, User Defined Rating Table, Culvert
User Defined Rating Table, Culvert (no Q): Riser
User Defined Rating Table, Culvert (no Q): Riser
User Defined Rating Table, Culvert (no Q): Riser
User Defined Rating Table, Culvert (no Q): Riser
User Defined Rating Table, Culvert (no Q): Riser
User Defined Rating Table, Culvert (no Q): Riser
User Defined Rating Table, Culvert (no Q): Riser
User Defined Rating Table, Culvert (no Q): Riser
User Defined Rating Table, Culvert (no Q): Riser

model3.ppc
3/5/2014

Bentley Systems, Inc. Headbad Methods Solution Center
27 Siemon Company Drive Suite 200 W. Waterdown, CT
06795 USA +1-203-755-1686

Bentley PondPack V8i
[06.11.01.50]
Page 124 of 203

Subsection: Outlet Input Data
Label: Blo 2

Return Event: 1 years
Storm Event: 1-Year

Requested Pond Water Surface Elevations	
Minimum (Headwater)	351.25 ft
Increment (Headwater)	0.50 ft
Maximum (Headwater)	355.25 ft

Outlet Connectivity

Structure Type	Outlet ID	Direction	Outfall	E1 (ft)	E2 (ft)
Inlet Box	Riser	Forward	Culvert	354.75	355.25
User Defined Table	Defined Railing Table	Forward	Culvert	0.00	355.25
Culvert-Circular	Culvert	Forward	TW	352.19	355.25
Tailwater Settings	Tailwater			(N/A)	(N/A)

Subsection: Outlet Input Data
Label: Blo 2

Return Event: 1 years
Storm Event: 1-Year

Structure ID: Riser	
Structure Type: Inlet Box	
Number of Openings	1
Elevation	354.75 ft
Orifice Area	16.0 ft ²
Orifice Coefficient	0.600
Weir Length	16.00 ft
Weir Coefficient	3.00 (ft ^{0.5} /s)
K Reverse	1.000
Manning's n	0.000
Key, Charged Riser	0.000
Weir Submergence	False
Orifice H to crest	False

Subsection: Outlet Input Data
Label: Blo 2

Return Event: 1 years
Storm Event: 1-Year

Structure ID: Culvert	
Structure Type: Culvert-Circular	
Number of Barrels	1
Diameter	15.0 in
Length	430.00 ft
Length (Computed Barrel)	430.15 ft
Slope (Computed)	0.026 ft/ft
Outlet Control Data	
Manning's n	0.013
Kc	0.200
Kb	0.023
Kr	0.000
Convergence Tolerance	0.00 ft
Inlet Control Data	
Equation Form	
K	Form 1
M	0.0045
C	2.0000
Y	0.0317
T1 ratio (HW/D)	0.6900
T2 ratio (HW/D)	1.082
Slope Correction Factor	1.184
	-0.500

Use unsubmerged inlet control O equation below T1 elevation.
Use submerged inlet control O equation above T2 elevation.

In transition zone between unsubmerged and submerged inlet control interpolate between flows at T1 & T2....

T1 Elevation	353.54 ft	T1 Flow	4.80 ft ³ /s
T2 Elevation	353.67 ft	T2 Flow	5.49 ft ³ /s

Subsection: Outlet Input Data
Label: Blo 2

Return Event: 1 years
Storm Event: 1-Year

Structure ID: User Defined Rating Table	
Structure Type: User Defined Table	
Elevation (ft)	Flow (ft ³ /s)
0.00	0.00
2.00	0.05
4.00	0.05
	0.05
Structure ID: TW	
Structure Type: TW Setup, DS Channel	
Tailwater Type: Free Outfall	
Convergence Tolerances	
Maximum Iterations	30
Tailwater Tolerance (Minimum)	0.01 ft
Tailwater Tolerance (Maximum)	0.50 ft
Headwater Tolerance (Minimum)	0.01 ft
Headwater Tolerance (Maximum)	0.50 ft
Flow Tolerance (Minimum)	0.001 ft ³ /s
Flow Tolerance (Maximum)	10,000 ft ³ /s

Subsection: Individual Outlet Curves
Label: Blo 2

Return Event: 1 years
Storm Event: 1-Year

RATING TABLE FOR ONE OUTLET TYPE
Structure ID = Riser (Inlet Box)

Upstream ID = (Pond Water Surface)
Downstream ID = Culvert (Culvert-Circular)

Water Surface Elevation (ft)	Device Flow (ft ³ /s)	Device Headwater Hydraulic Grade Line (ft)	Converge Downstream Hydraulic Grade Line (ft)	Next Downstream Hydraulic Grade Line (ft)	Downstream Hydraulic Grade Line Error (ft)		Downstream Channel Tailwater (ft)	Tailwater Error (ft)
					Hydraulic	Convergence Error (ft/s)		
351.25	0.00	0.00	0.00	0.00	0.00	0.00	(N/A)	0.00
351.75	0.00	0.00	0.00	0.00	0.00	0.00	(N/A)	0.00
352.19	0.00	0.00	0.00	0.00	0.00	0.00	(N/A)	0.00
352.25	0.00	0.00	0.00	352.25	0.00	0.00	(N/A)	0.00
352.75	0.00	0.00	0.00	352.31	0.00	0.00	(N/A)	0.00
353.25	0.00	0.00	0.00	352.31	0.00	0.00	(N/A)	0.00
353.25	0.00	0.00	0.00	352.31	0.00	0.00	(N/A)	0.00
354.25	0.00	0.00	0.00	352.31	0.00	0.00	(N/A)	0.00
354.75	0.00	0.00	0.00	352.31	0.00	0.00	(N/A)	0.00
355.25	16.97	355.25	355.25	355.25	0.00	0.00	(N/A)	0.00

Message:
WS below an invert; no flow.
WS below an invert; no flow.
WS below an invert; no flow.
WS below an invert; no flow.
WS below an invert; no flow.
WS below an invert; no flow.
WS below an invert; no flow.
WS below an invert; no flow.
FULLY CHARGED RISER: ADJUSTED TO WEIR: H = 0.5ft.

Subsection: Individual Outlet Curves
Label: Blo 2

Return Event: 1 years
Storm Event: 1-Year

RATING TABLE FOR ONE OUTLET TYPE
Structure ID = Culvert (Culvert-Circular)

Mannings open channel maximum capacity: 11.21 ft³/s
Upstream ID = Riser, User Defined Rating Table
Downstream ID = Tailwater (Pond Outfall)

Water Surface Elevation (ft)	Device Flow (ft ³ /s)	Device Headwater Hydraulic Grade Line (ft)	Converge Downstream Hydraulic Grade Line (ft)	Next Downstream Hydraulic Grade Line (ft)	Downstream Hydraulic Grade Line Error (ft)		Downstream Channel Tailwater (ft)	Tailwater Error (ft)
					Hydraulic	Convergence Error (ft/s)		
351.25	0.00	0.00	0.00	Free Outfall	0.00	0.00	(N/A)	0.00
351.75	0.00	0.00	0.00	Free Outfall	0.00	0.00	(N/A)	0.00
352.19	0.00	0.00	0.00	Free Outfall	0.00	0.00	(N/A)	0.00
352.25	0.01	352.25	Free Outfall	Free Outfall	0.00	0.04	(N/A)	0.00
352.75	0.05	352.31	Free Outfall	Free Outfall	0.00	0.00	(N/A)	0.00
353.25	0.05	352.31	Free Outfall	Free Outfall	0.00	0.00	(N/A)	0.00
353.75	0.05	352.31	Free Outfall	Free Outfall	0.00	0.00	(N/A)	0.00
354.25	0.05	352.31	Free Outfall	Free Outfall	0.00	0.00	(N/A)	0.00
354.75	0.05	352.31	Free Outfall	Free Outfall	0.00	0.00	(N/A)	0.00
355.25	10.25	355.25	Free Outfall	Free Outfall	0.00	6.77	(N/A)	0.00

Message:
WS below an invert; no flow.
WS below an invert; no flow.
WS below an invert; no flow.
CRIT-DEPTH CONTROL Vh= .014ft
Dcr= .041ft CRIT-DEPTH Hov= .00ft
CRIT-DEPTH CONTROL Vh= .029ft
Dcr= .085ft CRIT-DEPTH Hov= .00ft
CRIT-DEPTH CONTROL Vh= .029ft
Dcr= .085ft CRIT-DEPTH Hov= .00ft
CRIT-DEPTH CONTROL Vh= .029ft
Dcr= .085ft CRIT-DEPTH Hov= .00ft
CRIT-DEPTH CONTROL Vh= .029ft
Dcr= .085ft CRIT-DEPTH Hov= .00ft
CRIT-DEPTH CONTROL Vh= .029ft
Dcr= .085ft CRIT-DEPTH Hov= .00ft
INLET CONTROL... Submerged: HW =3.06

Subsection: Individual Outlet Curves
 Label: Bio 2

Return Event: 1 years
 Storm Event: 1-Year

RATING TABLE FOR ONE OUTLET TYPE
 Structure ID = User Defined Rating Table (User Defined Table)
 Downstream ID = Culvert (Culvert-Circular)

Water Surface Elevation (ft)	Device Flow (cfs)	Headwater Hydraulic Grade Line (ft)	Converge Downstream Hydraulic Grade Line (ft)	Next Downstream Hydraulic Grade Line (ft)	Downstream Hydraulic Grade Line Error (ft)	Convergence Error (ft ² /s)	Downstream Channel Tailwater (ft)	Tailwater Error (ft)
351.25	0.00	0.00	0.00	0.00	0.00	0.00	(N/A)	0.00
351.75	0.00	0.00	0.00	0.00	0.00	0.00	(N/A)	0.00
352.19	0.00	0.00	0.00	0.00	0.00	0.00	(N/A)	0.00
352.25	0.05	352.25	352.25	352.25	0.00	0.00	(N/A)	0.00
352.75	0.05	352.75	352.31	352.25	0.00	0.00	(N/A)	0.00
353.25	0.05	353.25	352.31	352.31	0.00	0.00	(N/A)	0.00
353.75	0.05	353.75	352.31	352.31	0.00	0.00	(N/A)	0.00
354.25	0.05	354.25	352.31	352.31	0.00	0.00	(N/A)	0.00
354.75	0.05	354.75	352.31	352.31	0.00	0.00	(N/A)	0.00
355.25	0.05	355.25	355.25	355.25	0.00	0.00	(N/A)	0.00

Message
 WS below an invert; no flow.
 WS below an invert; no flow.
 WS below an invert; no flow.
 FLOW PRECEDENCE SET TO DOWNSTREAM CONTROLLING STRUCTURE
 Interpolated from input table
 Interpolated from input table
 Interpolated from input table

Subsection: Composite Rating Curve
 Label: Bio 2

Return Event: 1 years
 Storm Event: 1-Year

Composite Outflow Summary

Water Surface Elevation (ft)	Flow (cfs)	Tailwater Elevation (ft)	Convergence Error (ft)
351.25	0.00	(N/A)	0.00
351.75	0.00	(N/A)	0.00
352.19	0.00	(N/A)	0.00
352.25	0.01	(N/A)	0.00
352.75	0.05	(N/A)	0.00
353.25	0.05	(N/A)	0.00
353.75	0.05	(N/A)	0.00
354.25	0.05	(N/A)	0.00
354.75	0.05	(N/A)	0.00
355.25	10.25	(N/A)	0.00

Contributing Structures
 (no Q; Riser, User Defined Rating Table, Culvert)
 (no Q; Riser, User Defined Rating Table, Culvert)
 (no Q; Riser, User Defined Rating Table, Culvert)
 (no Q; Riser, User Defined Rating Table, Culvert)
 User Defined Rating Table, Culvert (no Q; Riser)
 User Defined Rating Table, Culvert (no Q; Riser)
 User Defined Rating Table, Culvert (no Q; Riser)
 User Defined Rating Table, Culvert (no Q; Riser)
 User Defined Rating Table, Culvert (no Q; Riser)
 User Defined Rating Table, Culvert (no Q; Riser)
 User Defined Rating Table, Culvert (no Q; Riser)
 User Defined Rating Table, Culvert (no Q; Riser)

Bentley ProjectPack V8i
 [06.11.01.50]
 Page 131 of 203

Bentley Systems, Inc. Headstad Methods Solution Center
 27 Siemon Company Drive Suite 200 W Watertown, CT
 06795 USA +1-203-755-1886

mod3d.ppc
 3/5/2014

Bentley ProjectPack V8i
 [06.11.01.50]
 Page 132 of 203

Bentley Systems, Inc. Headstad Methods Solution Center
 27 Siemon Company Drive Suite 200 W Watertown, CT
 06795 USA +1-203-755-1886

mod3d.ppc
 3/5/2014

Subsection: Outlet Input Data
Label: Bio 3

Return Event: 1 years
Storm Event: 1-Year

Requested Pond Water Surface Elevations	
Minimum (Headwater)	352.00 ft
Increment (Headwater)	0.50 ft
Maximum (Headwater)	356.00 ft

Outlet Connectivity

Structure Type	Outlet ID	Direction	Outlet	E1 (ft)	E2 (ft)
Inlet Box	Riser	Forward	Culvert	355.50	356.00
User Defined Rating Table	Rating Table	Forward	Culvert	0.00	356.00
Culvert-Circular	Culvert	Forward	TW	352.00 (N/A)	356.00 (N/A)
Tailwater Settings	Tailwater				

Subsection: Outlet Input Data
Label: Bio 3

Return Event: 1 years
Storm Event: 1-Year

Structure ID: User Defined Rating Table
Structure Type: User Defined Table

Elevation (ft)	Flow (ft ³ /s)
0.00	0.05
2.00	0.05
4.00	0.05

Structure ID: Riser
Structure Type: Inlet Box

Number of Openings: 1
Elevation: 355.50 ft
Orifice Area: 16.0 ft²
Orifice Coefficient: 0.600
Weir Length: 16.00 ft
Weir Coefficient: 3.00 (ft^{-0.5})/s
K Reverse: 1.000
Manning's n: 0.000
Key, Charged Riser: 0.000
Weir Submergence: False
Orifice H to crest: False

Structure ID: Culvert
Structure Type: Culvert-Circular

Number of Barrels: 1
Diameter: 15.0 in
Length: 610.00 ft
Length (Computed Barrel): 610.02 ft
Slope (Computed): 0.008 ft/ft

Outlet Control Data

Manning's n: 0.013
Ke: 0.200
Kb: 0.023
Kr: 0.000
Convergence Tolerance: 0.00 ft

Inlet Control Data

Equation Form: Form 1
K: 0.0045
M: 2.0000
C: 0.0317
Y: 0.6900
T1 ratio (HW/D): 1.091
T2 ratio (HW/D): 1.193
Slope Correction Factor: -0.500

Subsection: Outlet Input Data
Label: B10 3

Return Event: 1 years
Storm Event: 1-Year

Use unsubmerged inlet control 0 equation below T1 elevation.
Use submerged inlet control 0 equation above T2 elevation

In transition zone between unsubmerged and submerged inlet control, interpolate between flows at T1 & T2...

	T1 Elevation	T2 Elevation	T1 Flow	T2 Flow
	353.36 ft	353.49 ft	4.80 ft ² /s	5.49 ft ² /s

Subsection: Outlet Input Data
Label: B10 3

Return Event: 1 years
Storm Event: 1-Year

Structure ID: TW	
Structure Type: TW Setup, DS Channel	
Tailwater Type: Free Outfall	
Convergence Tolerances	
Maximum Iterations	30
Tailwater Tolerance (Minimum)	0.01 ft
Tailwater Tolerance (Maximum)	0.50 ft
Headwater Tolerance (Minimum)	0.01 ft
Headwater Tolerance (Maximum)	0.50 ft
Flow Tolerance (Minimum)	0.001 ft ² /s
Flow Tolerance (Maximum)	10.000 ft ² /s

Subsection: Individual Outlet Curves
Label: Bio 3

Return Event: 1 years
Storm Event: 1-Year

RATING TABLE FOR ONE OUTLET TYPE
STRUCTURE ID = User Defined Rating Table (User Defined Table)

Upstream ID = (Pond Water Surface)
Downstream ID = Culvert (Culvert-Circular)

Water Surface Elevation (ft)	Device Flow (ft ³ /s)	(into) Headwater Hydraulic Grade Line (ft)	Converge Downstream Hydraulic Grade Line (ft)	Next Downstream Hydraulic Grade Line (ft)	Downstream Hydraulic Grade Line Error (ft)	Convergence Error (ft ³ /s)	Downstream Channel Tailwater (ft)	Tailwater Error (ft)
352.00	0.00	0.00	0.00	0.00	0.00	0.00	(N/A)	0.00
352.50	0.05	352.50	352.12	352.12	0.00	0.00	(N/A)	0.00
353.00	0.05	353.00	352.12	352.12	0.00	0.00	(N/A)	0.00
353.50	0.05	353.50	352.12	352.12	0.00	0.00	(N/A)	0.00
354.00	0.05	354.00	352.12	352.12	0.00	0.00	(N/A)	0.00
354.50	0.05	354.50	352.12	352.12	0.00	0.00	(N/A)	0.00
355.00	0.05	355.00	352.12	352.12	0.00	0.00	(N/A)	0.00
355.50	0.05	355.50	352.12	352.12	0.00	0.00	(N/A)	0.00
356.00	0.05	356.00	356.00	356.00	0.00	0.00	(N/A)	0.00

Message

WS below an invert; no flow.
Interpolated from input table
Interpolated from input table
Interpolated from input table
Interpolated from input table
Interpolated from input table
Interpolated from input table
FLOW PRECEDENCE SET TO DOWNSTREAM CONTROLLING STRUCTURE

Subsection: Individual Outlet Curves
Label: Bio 3

Return Event: 1 years
Storm Event: 1-Year

RATING TABLE FOR ONE OUTLET TYPE
STRUCTURE ID = Riser (Inlet Box)

Upstream ID = (Pond Water Surface)
Downstream ID = Culvert (Culvert-Circular)

Water Surface Elevation (ft)	Device Flow (ft ³ /s)	(into) Headwater Hydraulic Grade Line (ft)	Converge Downstream Hydraulic Grade Line (ft)	Next Downstream Hydraulic Grade Line (ft)	Downstream Hydraulic Grade Line Error (ft)	Convergence Error (ft ³ /s)	Downstream Channel Tailwater (ft)	Tailwater Error (ft)
352.00	0.00	0.00	0.00	0.00	0.00	0.00	(N/A)	0.00
352.50	0.00	0.00	0.00	0.00	0.00	0.00	(N/A)	0.00
353.00	0.00	0.00	0.00	0.00	0.00	0.00	(N/A)	0.00
353.50	0.00	0.00	0.00	0.00	0.00	0.00	(N/A)	0.00
354.00	0.00	0.00	0.00	0.00	0.00	0.00	(N/A)	0.00
354.50	0.00	0.00	0.00	0.00	0.00	0.00	(N/A)	0.00
355.00	0.00	0.00	0.00	0.00	0.00	0.00	(N/A)	0.00
355.50	0.00	0.00	0.00	0.00	0.00	0.00	(N/A)	0.00
356.00	16.97	356.00	356.00	356.00	0.00	0.00	(N/A)	0.00

Message

WS below an invert; no flow.
WS below an invert; no flow.
WS below an invert; no flow.
WS below an invert; no flow.
WS below an invert; no flow.
WS below an invert; no flow.
WS below an invert; no flow.
FULLY CHARGED RISER.
DOWNSTREAM CONTROL: Key=0.
Hlev=0.00

Subsection: Individual Outlet Curves
Label: Blo 3

Return Event: 1 years
Storm Event: 1-Year

RATING TABLE FOR ONE OUTLET TYPE
Structure ID = Culvert (Culvert-Circular)

Mannings open channel maximum capacity: 6.29 ft³/s
Upstream ID = Riser, User Defined Rating Table
Downstream ID = Tailwater (Pond Outfall)

Water Surface Elevation (ft)	Flow (ft ³ /s)	Hydraulic Grade Line (ft)	Downstream Hydraulic Grade Line (ft)	Convergence Error (ft ³ /s)	Downstream Hydraulic Error (ft)	Channel Tailwater (ft)	Tailwater Error (ft)
352.00	0.00	0.00	Free Outfall	0.00	0.00	(N/A)	0.00
352.50	0.05	352.12	Free Outfall	0.00	0.00	(N/A)	0.00
353.00	0.05	352.12	Free Outfall	0.00	0.00	(N/A)	0.00
353.50	0.05	352.12	Free Outfall	0.00	0.00	(N/A)	0.00
354.00	0.05	352.12	Free Outfall	0.00	0.00	(N/A)	0.00
354.50	0.05	352.12	Free Outfall	0.00	0.00	(N/A)	0.00
355.00	0.05	352.12	Free Outfall	0.00	0.00	(N/A)	0.00
355.50	0.05	352.12	Free Outfall	0.00	0.00	(N/A)	0.00
356.00	7.04	356.00	Free Outfall	0.00	9.98	(N/A)	0.00

Message
WS below an invert: no flow.
CRIT.DEPTH CONTROL Vh=.029ft
Dcr=.085ft CRIT.DEPTH Hev=.00ft
CRIT.DEPTH CONTROL Vh=.029ft
Dcr=.085ft CRIT.DEPTH Hev=.00ft
CRIT.DEPTH CONTROL Vh=.029ft
Dcr=.085ft CRIT.DEPTH Hev=.00ft
CRIT.DEPTH CONTROL Vh=.029ft
Dcr=.085ft CRIT.DEPTH Hev=.00ft
CRIT.DEPTH CONTROL Vh=.029ft
Dcr=.085ft CRIT.DEPTH Hev=.00ft
CRIT.DEPTH CONTROL Vh=.029ft
Dcr=.085ft CRIT.DEPTH Hev=.00ft
FULL FLOW...LFull=579.62ft Vh=.512ft
HL=7.501ft Hev=.00ft

Subsection: Composite Rating Curve
Label: Blo 3

Return Event: 1 years
Storm Event: 1-Year

Composite Outflow Summary

Water Surface Elevation (ft)	Flow (ft ³ /s)	Tailwater Elevation (ft)	Convergence Error (ft)
352.00	0.00	(N/A)	0.00
352.50	0.05	(N/A)	0.00
353.00	0.05	(N/A)	0.00
353.50	0.05	(N/A)	0.00
354.00	0.05	(N/A)	0.00
354.50	0.05	(N/A)	0.00
355.00	0.05	(N/A)	0.00
355.50	0.05	(N/A)	0.00
356.00	7.04	(N/A)	0.00

Contributing Structures
(No Q; Riser; User Defined Rating Table; Culvert)
User Defined Rating Table; Culvert (no Q; Riser)
User Defined Rating Table; Culvert (no Q; Riser)
User Defined Rating Table; Culvert (no Q; Riser)
User Defined Rating Table; Culvert (no Q; Riser)
User Defined Rating Table; Culvert (no Q; Riser)
User Defined Rating Table; Culvert (no Q; Riser)
Riser; User Defined Rating Table; Culvert

Subsection: Outlet Input Data
Label: Bto 4

Return Event: 1 years
Storm Event: 1-Year

Requested Pond Water Surface Elevations	
Minimum (Headwater)	351.00 ft
Increment (Headwater)	0.50 ft
Maximum (Headwater)	355.00 ft

Outlet Connectivity

Structure Type	Outlet ID	Direction	Outfall	E1 (ft)	E2 (ft)
Inlet Box	Riser	Forward	Culvert	354.50	355.00
User Defined Table	User Defined Rating Table	Forward	Culvert	0.00	355.00
Culvert-Circular	Culvert	Forward	TW	351.00	355.00
Tailwater Settings	Tailwater			(N/A)	(N/A)

Subsection: Outlet Input Data
Label: Bto 4

Return Event: 1 years
Storm Event: 1-Year

Structure ID: User Defined Rating Table
Structure Type: User Defined Table

Elevation (ft)	Flow (ft ³ /s)
0.00	0.05
2.00	0.05
4.00	0.05

Structure ID: Riser
Structure Type: Inlet Box

Number of Openings	1
Elevation	354.50 ft
Orifice Area	15.0 ft ²
Orifice Coefficient	0.600
Weir Length	16.00 ft
Weir Coefficient	3.00 (ft ^{0.5} /s)
K Reverse	1.000
Manning's n	0.000
Key, Charged Riser	0.000
Weir Submergence	False
Orifice H to crest	False

Structure ID: Culvert
Structure Type: Culvert-Circular

Number of Barrels	1
Diameter	15.0 in
Length	535.00 ft
Length (Computed Barrel)	535.01 ft
Slope (Computed)	0.007 ft/ft

Outlet Control Data

Manning's n	0.013
Kc	0.200
Kb	0.023
Kr	0.000
Convergence Tolerance	0.00 ft

Inlet Control Data

Equation Form	Form 1
K	0.0045
M	2.0000
C	0.0317
Y	0.6900
T1 ratio (HW/D)	1.091
T2 ratio (HW/D)	1.193
Slope Correction Factor	-0.500

Subsection: Outlet Input Data
Label: Blo 4

Return Event: 1 years
Storm Event: 1-Year

Use unsubmerged inlet control 0 equation below T1 elevation.
Use submerged inlet control 0 equation above T2 elevation

in transition zone between unsubmerged and submerged inlet control
interpolate between flows at T1 & T2...

	T1 Elevation	T1 Flow	T2 Elevation	T2 Flow
	352.36 ft	4.80 ft ³ /s	352.49 ft	5.49 ft ³ /s

Subsection: Outlet Input Data
Label: Blo 4

Return Event: 1 years
Storm Event: 1-Year

Structure ID:	TW Setup, DS Channel
Tailwater Type:	Free Outfall
Convergence Tolerances	
Maximum Iterations	30
Tailwater Tolerance (Minimum)	0.01 ft
Tailwater Tolerance (Maximum)	0.50 ft
Headwater Tolerance (Minimum)	0.01 ft
Headwater Tolerance (Maximum)	0.50 ft
Flow Tolerance (Minimum)	0.001 ft ³ /s
Flow Tolerance (Maximum)	10.000 ft ³ /s

Subsection: Individual Outlet Curves
Label: Blo 4

Return Event: 1 year
Storm Event: 1-Year

RATING TABLE FOR ONE OUTLET TYPE
Structure ID = User Defined Rating Table (User Defined Table)

Upstream ID = (Pond Water Surface)
Downstream ID = Culvert (Culvert-Circular)

Water Surface Elevation (ft)	Device Flow (ft ³ /s)	(into) Headwater Hydraulic Grade Line (ft)	Converge Downstream Hydraulic Grade Line (ft)	Next Downstream Hydraulic Grade Line (ft)	Downstream Hydraulic Grade Line Error (ft)	Convergence Error (ft/s)	Downstream Channel Tailwater (ft)	Tailwater Error (ft)
351.00	0.00	0.00	0.00	0.00	0.00	0.00	(N/A)	0.00
351.50	0.05	351.50	351.12	351.12	0.00	0.00	(N/A)	0.00
352.00	0.05	352.00	351.12	351.12	0.00	0.00	(N/A)	0.00
352.50	0.05	352.50	351.12	351.12	0.00	0.00	(N/A)	0.00
353.00	0.05	353.00	351.12	351.12	0.00	0.00	(N/A)	0.00
353.50	0.05	353.50	351.12	351.12	0.00	0.00	(N/A)	0.00
354.00	0.05	354.00	351.12	351.12	0.00	0.00	(N/A)	0.00
354.50	0.05	354.50	351.12	351.12	0.00	0.00	(N/A)	0.00
355.00	0.05	355.00	355.00	355.00	0.00	0.00	(N/A)	0.00

Message

WS below an invert; no flow.
Interpolated from input table
Interpolated from input table
Interpolated from input table
Interpolated from input table
Interpolated from input table
Interpolated from input table
FLOW PRECEDENCE SET TO DOWNSTREAM CONTROLLING STRUCTURE

Subsection: Individual Outlet Curves
Label: Blo 4

Return Event: 1 year
Storm Event: 1-Year

RATING TABLE FOR ONE OUTLET TYPE
Structure ID = Riser (Inlet Box)

Upstream ID = (Pond Water Surface)
Downstream ID = Culvert (Culvert-Circular)

Water Surface Elevation (ft)	Device Flow (ft ³ /s)	(into) Headwater Hydraulic Grade Line (ft)	Converge Downstream Hydraulic Grade Line (ft)	Next Downstream Hydraulic Grade Line (ft)	Downstream Hydraulic Grade Line Error (ft)	Convergence Error (ft/s)	Downstream Channel Tailwater (ft)	Tailwater Error (ft)
351.00	0.00	0.00	0.00	0.00	0.00	0.00	(N/A)	0.00
351.50	0.00	0.00	0.00	0.00	0.00	0.00	(N/A)	0.00
352.00	0.00	0.00	0.00	0.00	0.00	0.00	(N/A)	0.00
352.50	0.00	0.00	0.00	0.00	0.00	0.00	(N/A)	0.00
353.00	0.00	0.00	0.00	0.00	0.00	0.00	(N/A)	0.00
353.50	0.00	0.00	0.00	0.00	0.00	0.00	(N/A)	0.00
354.00	0.00	0.00	0.00	0.00	0.00	0.00	(N/A)	0.00
354.50	0.00	0.00	0.00	0.00	0.00	0.00	(N/A)	0.00
355.00	16.97	355.00	355.00	355.00	0.00	0.00	(N/A)	0.00

Message

WS below an invert; no flow.
WS below an invert; no flow.
WS below an invert; no flow.
WS below an invert; no flow.
WS below an invert; no flow.
WS below an invert; no flow.
WS below an invert; no flow.
FULLY CHARGED RISER.
DOWNSTREAM CONTROL: Key=0.
Hcr=0.00

Subsection: Individual Outlet Curves
Label: B10 4

Return Event: 1 years
Storm Event: 1-Year

RATING TABLE FOR ONE OUTLET TYPE
Structure ID = Culvert (Culvert-Circular)

Mannings open channel maximum capacity: 6.01 ft³/s
Upstream ID = Riser, User Defined Rating Table
Downstream ID = Tailwater (Pond Outfall)

Water Surface Elevation (ft)	Flow (ft ³ /s)	Headwater Hydraulic Grade Line (ft)	Downstream Hydraulic Grade Line (ft)	Convergence Error (ft ³ /s)	Downstream Hydraulic Grade Line Error (ft)	Channel Tailwater (ft)	Tailwater Error (ft)
351.00	0.00	0.00	0.00	0.00	0.00	(N/A)	0.00
351.50	0.05	351.12	Free Outfall	0.00	0.00	(N/A)	0.00
352.00	0.05	351.12	Free Outfall	0.00	0.00	(N/A)	0.00
352.50	0.05	351.12	Free Outfall	0.00	0.00	(N/A)	0.00
353.00	0.05	351.12	Free Outfall	0.00	0.00	(N/A)	0.00
353.50	0.05	351.12	Free Outfall	0.00	0.00	(N/A)	0.00
354.00	0.05	351.12	Free Outfall	0.00	0.00	(N/A)	0.00
354.50	0.05	351.12	Free Outfall	0.00	0.00	(N/A)	0.00
355.00	6.98	355.00	Free Outfall	10.04	10.04	(N/A)	0.00

Message

WS below an invert; no flow.
CRIT.DEPTH CONTROL Vh=.029ft
Dcr=.085ft CRIT.DEPTH Hey=.00ft
CRIT.DEPTH CONTROL Vh=.029ft
Dcr=.085ft CRIT.DEPTH Hey=.00ft
CRIT.DEPTH CONTROL Vh=.029ft
Dcr=.085ft CRIT.DEPTH Hey=.00ft
CRIT.DEPTH CONTROL Vh=.029ft
Dcr=.085ft CRIT.DEPTH Hey=.00ft
CRIT.DEPTH CONTROL Vh=.029ft
Dcr=.085ft CRIT.DEPTH Hey=.00ft
CRIT.DEPTH CONTROL Vh=.029ft
Dcr=.085ft CRIT.DEPTH Hey=.00ft
FULL.FLOW...Lfull=509.61ft Vh=503ft
HL=6.561ft Hey=.00ft

Subsection: Composite Rating Curve
Label: B10 4

Return Event: 1 years
Storm Event: 1-Year

Composite Outflow Summary

Water Surface Elevation (ft)	Flow (ft ³ /s)	Tailwater Elevation (ft)	Convergence Error (ft)
351.00	0.00	(N/A)	0.00
351.50	0.05	(N/A)	0.00
352.00	0.05	(N/A)	0.00
352.50	0.05	(N/A)	0.00
353.00	0.05	(N/A)	0.00
353.50	0.05	(N/A)	0.00
354.00	0.05	(N/A)	0.00
354.50	0.05	(N/A)	0.00
355.00	6.98	(N/A)	0.00

Contributing Structures

(no Q; Riser, User Defined Rating Table, Culvert)
User Defined Rating Table, Culvert (no Q; Riser)
User Defined Rating Table, Culvert (no Q; Riser)
User Defined Rating Table, Culvert (no Q; Riser)
User Defined Rating Table, Culvert (no Q; Riser)
User Defined Rating Table, Culvert (no Q; Riser)
User Defined Rating Table, Culvert (no Q; Riser)
User Defined Rating Table, Culvert (no Q; Riser)
User Defined Rating Table, Culvert (no Q; Riser)
User Defined Rating Table, Culvert (no Q; Riser)
Riser, User Defined Rating Table, Culvert

Subsection: Outlet Input Data
Label: B10 5

Return Event: 1 years
Storm Event: 1-Year

Requested Pond Water Surface Elevations	
Minimum (Headwater)	350.33 ft
Increment (Headwater)	0.50 ft
Maximum (Headwater)	354.33 ft

Outlet Connectivity

Structure Type	Outlet ID	Direction	Outfall	E1 (ft)	E2 (ft)
Inlet Box	Riser	Forward	Culvert	353.83	354.33
User Defined Table	User Defined Rating Table	Forward	Culvert	0.00	354.33
Culvert-Circular Tailwater Settings	Culvert Tailwater	Forward	TW	350.33 (N/A)	354.33 (N/A)

Subsection: Outlet Input Data
Label: B10 5

Return Event: 1 years
Storm Event: 1-Year

Structure ID: User Defined Rating Table
Structure Type: User Defined Table

Elevation (ft)	Flow (ft ³ /s)
0.00	0.05
2.00	0.05
4.00	0.05

Structure ID: Riser
Structure Type: Inlet Box

Number of Openings: 1

Elevation: 353.83 ft

Orifice Area: 16.0 ft²

Orifice Coefficient: 0.600

Weir Length: 16.00 ft

Weir Coefficient: 3.00 (ft³*0.5)/s

K Reverse: 1.000

Manning's n: 0.000

Key, Charged Riser: 0.000

Weir Submergence: False

Orifice H to crest: False

Structure ID: Culvert
Structure Type: Culvert-Circular

Number of Barrels: 1

Diameter: 15.0 in

Length: 465.00 ft

Length (Computed Barrel): 465.01 ft

Slope (Computed): 0.007 ft/ft

Outlet Control Data

Manning's n: 0.013

Ke: 0.200

Kb: 0.023

Kr: 0.000

Convergence Tolerance: 0.00 ft

Inlet Control Data

Equation Form: Form 1

K: 0.0045

M: 2.0000

C: 0.0317

Y: 0.6900

T1 ratio (HW/D): 1.052

T2 ratio (HW/D): 1.194

Slope Correction Factor: -0.500

Subsection: Outlet Input Data
Label: Blo 5

Return Event: 1 years
Storm Event: 1-Year

Use unsubmerged inlet control 0 equation below T1 elevation.
Use submerged inlet control 0 equation above T2 elevation

in transition zone between unsubmerged and submerged inlet control, interpolate between flows at T1 & T2...

	T1 Flow	T2 Flow
T1 Elevation	351.69 ft	4.80 ft ³ /s
T2 Elevation	351.82 ft	5.49 ft ³ /s

Subsection: Outlet Input Data
Label: Blo 5

Return Event: 1 years
Storm Event: 1-Year

Structure ID: TW	Free Outfall
Structure Type: TW Setup, DS Channel	
Tailwater Type	
Convergence Tolerances	
Maximum Iterations	30
Tailwater Tolerance (Minimum)	0.01 ft
Tailwater Tolerance (Maximum)	0.50 ft
Headwater Tolerance (Minimum)	0.01 ft
Headwater Tolerance (Maximum)	0.50 ft
Flow Tolerance (Minimum)	0.001 ft ³ /s
Flow Tolerance (Maximum)	10.000 ft ³ /s

Subsection: Individual Outlet Curves
Label: Blo 5

Return Event: 1 years
Storm Event: 1-Year

RATING TABLE FOR ONE OUTLET TYPE
Structure ID = User Defined Rating Table (User Defined Table)

Upstream ID = (Pond Water Surface)
Downstream ID = Culvert (Culvert-Circular)

Water Surface Elevation (ft)	Device Flow (ft ³ /s)	(ft/s)	Headwater Hydraulic Grade Line (ft)	(ft)	Converge Downstream Hydraulic Grade Line (ft)	Next Downstream Hydraulic Grade Line (ft)	Downstream Hydraulic Grade Line Error (ft)	Convergence Error (ft/s)	Downstream Channel Tailwater (ft)	Tailwater Error (ft)
350.33	0.00	0.00	0.00	0.00	0.00	0.00	0.00	0.00	(N/A)	0.00
350.83	0.05	350.83	350.45	350.45	350.45	350.45	0.00	0.00	(N/A)	0.00
351.33	0.05	351.33	350.45	350.45	350.45	350.45	0.00	0.00	(N/A)	0.00
351.83	0.05	351.83	350.45	350.45	350.45	350.45	0.00	0.00	(N/A)	0.00
352.33	0.05	352.33	350.45	350.45	350.45	350.45	0.00	0.00	(N/A)	0.00
352.83	0.05	352.83	350.45	350.45	350.45	350.45	0.00	0.00	(N/A)	0.00
353.33	0.05	353.33	350.45	350.45	350.45	350.45	0.00	0.00	(N/A)	0.00
353.83	0.05	353.83	350.45	350.45	350.45	350.45	0.00	0.00	(N/A)	0.00
354.33	0.05	354.33	354.33	354.33	354.33	354.33	0.00	0.00	(N/A)	0.00

Message
WS below an invert; no flow.
Interpolated from input table
Interpolated from input table
Interpolated from input table
Interpolated from input table
Interpolated from input table
Interpolated from input table
FLOW PREFERENCE SET TO DOWNSTREAM CONTROLLING STRUCTURE

Subsection: Individual Outlet Curves
Label: Blo 5

Return Event: 1 years
Storm Event: 1-Year

RATING TABLE FOR ONE OUTLET TYPE
Structure ID = Riser (Inlet Box)

Upstream ID = (Pond Water Surface)
Downstream ID = Culvert (Culvert-Circular)

Water Surface Elevation (ft)	Device Flow (ft ³ /s)	(ft/s)	Headwater Hydraulic Grade Line (ft)	(ft)	Converge Downstream Hydraulic Grade Line (ft)	Next Downstream Hydraulic Grade Line (ft)	Downstream Hydraulic Grade Line Error (ft)	Convergence Error (ft/s)	Downstream Channel Tailwater (ft)	Tailwater Error (ft)
350.33	0.00	0.00	0.00	0.00	0.00	0.00	0.00	0.00	(N/A)	0.00
350.83	0.00	0.00	0.00	0.00	0.00	350.45	0.00	0.00	(N/A)	0.00
351.33	0.00	0.00	0.00	0.00	0.00	350.45	0.00	0.00	(N/A)	0.00
351.83	0.00	0.00	0.00	0.00	0.00	350.45	0.00	0.00	(N/A)	0.00
352.33	0.00	0.00	0.00	0.00	0.00	350.45	0.00	0.00	(N/A)	0.00
352.83	0.00	0.00	0.00	0.00	0.00	350.45	0.00	0.00	(N/A)	0.00
353.33	0.00	0.00	0.00	0.00	0.00	350.45	0.00	0.00	(N/A)	0.00
353.83	0.00	0.00	0.00	0.00	0.00	350.45	0.00	0.00	(N/A)	0.00
354.33	16.97	354.33	354.33	354.33	354.33	354.33	0.00	0.00	(N/A)	0.00

Message
WS below an invert; no flow.
WS below an invert; no flow.
WS below an invert; no flow.
WS below an invert; no flow.
WS below an invert; no flow.
WS below an invert; no flow.
WS below an invert; no flow.
FULLY CHARGED RISER.
DOWNSTREAM CONTROL: Key=0.
Key=0.000

Subsection: Individual Outlet Curves
Label: Blo 5

Return Event: 1 years
Storm Event: 1-Year

Manning's open channel maximum capacity: 5.88 ft³/s
Upstream ID = Riser, User Defined Rating Table
Downstream ID = Tailwater (Pond Outfall)

Structure ID	Device	Flow Elevation (ft)	Headwater Hydraulic Grade Line (ft)	Converge Downstream Hydraulic Grade Line (ft)	Next Downstream Hydraulic Grade Line (ft)	Downstream Hydraulic Grade Line Error (ft)	Convergence Error (ft ² /s)	Downstream Channel Tailwater (ft)	Tailwater Error (ft)
350.33	0.00	0.00	Free Outfall	Free Outfall	Free Outfall	0.00	0.00	(N/A)	0.00
350.83	0.05	350.45	Free Outfall	Free Outfall	Free Outfall	0.00	0.00	(N/A)	0.00
351.33	0.05	350.45	Free Outfall	Free Outfall	Free Outfall	0.00	0.00	(N/A)	0.00
351.83	0.05	350.45	Free Outfall	Free Outfall	Free Outfall	0.00	0.00	(N/A)	0.00
352.33	0.05	350.45	Free Outfall	Free Outfall	Free Outfall	0.00	0.00	(N/A)	0.00
352.83	0.05	350.45	Free Outfall	Free Outfall	Free Outfall	0.00	0.00	(N/A)	0.00
353.33	0.05	350.45	Free Outfall	Free Outfall	Free Outfall	0.00	0.00	(N/A)	0.00
353.83	0.05	350.45	Free Outfall	Free Outfall	Free Outfall	0.00	0.00	(N/A)	0.00
354.33	7.06	354.33	Free Outfall	Free Outfall	Free Outfall	0.00	9.96	(N/A)	0.00

Message

WS below an invert; no flow.
CRIT-DEPTH CONTROL Vh=.029ft
Dcr=.085ft CRIT-DEPTH Hey=.00ft
CRIT-DEPTH CONTROL Vh=.029ft
Dcr=.085ft CRIT-DEPTH Hey=.00ft
CRIT-DEPTH CONTROL Vh=.029ft
Dcr=.085ft CRIT-DEPTH Hey=.00ft
CRIT-DEPTH CONTROL Vh=.029ft
Dcr=.085ft CRIT-DEPTH Hey=.00ft
CRIT-DEPTH CONTROL Vh=.029ft
Dcr=.085ft CRIT-DEPTH Hey=.00ft
CRIT-DEPTH CONTROL Vh=.029ft
Dcr=.085ft CRIT-DEPTH Hey=.00ft
CRIT-DEPTH CONTROL Vh=.029ft
Dcr=.085ft CRIT-DEPTH Hey=.00ft
CRIT-DEPTH CONTROL Vh=.029ft
Dcr=.085ft CRIT-DEPTH Hey=.00ft
FULL FLOW...Lfull=444.43ft Vh=515ft
HL=593.8ft Hey=.00ft

Bentley PondPack V8i
[06.11.01.50]
Page 155 of 203

Bentley Systems, Inc. Horizontal Methods Solution Center
27 Siemon Company Drive Suite 200 W. Watertown, CT
06785 USA +1-203-755-1686

model3.ppc
3/5/2014

Subsection: Composite Rating Curve
Label: Blo 5

Return Event: 1 years
Storm Event: 1-Year

Composite Outflow Summary

Water Surface Elevation (ft)	Flow (ft ³ /s)	Tailwater Elevation (ft)	Convergence Error (ft)
350.33	0.00	(N/A)	0.00
350.83	0.05	(N/A)	0.00
351.33	0.05	(N/A)	0.00
351.83	0.05	(N/A)	0.00
352.33	0.05	(N/A)	0.00
352.83	0.05	(N/A)	0.00
353.33	0.05	(N/A)	0.00
353.83	0.05	(N/A)	0.00
354.33	7.06	(N/A)	0.00

Contributing Structures

(no Q; Riser, User Defined Rating
Table, Culvert)
User Defined Rating Table, Culvert (no
Q; Riser)
User Defined Rating Table, Culvert (no
Q; Riser)
User Defined Rating Table, Culvert (no
Q; Riser)
User Defined Rating Table, Culvert (no
Q; Riser)
User Defined Rating Table, Culvert (no
Q; Riser)
User Defined Rating Table, Culvert (no
Q; Riser)
User Defined Rating Table, Culvert (no
Q; Riser)
User Defined Rating Table, Culvert (no
Q; Riser)
Riser, User Defined Rating
Table, Culvert

model3.ppc
3/5/2014

Bentley Systems, Inc. Horizontal Methods Solution Center
27 Siemon Company Drive Suite 200 W. Watertown, CT
06785 USA +1-203-755-1686

Bentley PondPack V8i
[06.11.01.50]
Page 156 of 203

Subsection: Outlet Input Data
Label: Bio 6

Return Event: 1 years
Storm Event: 1-Year

Requested Pond Water Surface Elevations	
Minimum (Headwater)	348.50 ft
Increment (Headwater)	0.50 ft
Maximum (Headwater)	352.50 ft

Outlet Connectivity

Structure Type	Outlet ID	Direction	Outfall	E1 (ft)	E2 (ft)
Inlet Box	Riser	Forward	Culvert	352.00	352.50
User Defined Table	User Defined Rating Table	Forward	Culvert	0.00	352.50
Culvert-Circular Tailwater Settings	Culvert Tailwater	Forward	TW	348.50 (N/A)	352.50 (N/A)

Subsection: Outlet Input Data
Label: Bio 6

Return Event: 1 years
Storm Event: 1-Year

Structure ID: User Defined Rating Table
Structure Type: User Defined Table

Elevation (ft)	Flow (ft ³ /s)
0.00	0.05
2.00	0.05
4.00	0.05

Structure ID: Riser
Structure Type: Inlet Box

Number of Openings	1
Elevation	352.00 ft
Orifice Area	16.0 ft ²
Orifice Coefficient	0.600
Weir Length	16.00 ft
Weir Coefficient	3.00 (ft ^{0.5} /s)
K Reverse	1.000
Manning's n	0.000
KeV, Charged Riser	0.000
Weir Submergence	False
Orifice H to crest	False

Structure ID: Culvert
Structure Type: Culvert-Circular

Number of Barrels	1
Diameter	15.0 in
Length	278.00 ft
Length (Computed Barrel)	278.08 ft
Slope (Computed)	0.023 ft/ft

Outlet Control Data

Manning's n	0.013
Kc	0.200
Kb	0.023
Kr	0.000
Convergence Tolerance	0.00 ft

Inlet Control Data

Equation Form	Form 1
K	0.0045
M	2.0000
C	0.0317
Y	0.6900
T1 ratio (HW/D)	1.084
T2 ratio (HW/D)	1.166
Slope Correction Factor	-0.500

Subsection: Outlet Input Data
Label: Blo 6

Return Event: 1 years
Storm Event: 1-Year

Use unsubmerged inlet control 0 equation below T1 elevation.
Use submerged inlet control 0 equation above T2 elevation

In transition zone between unsubmerged and submerged inlet control, interpolate between flows at T1 & T2...

	T1 Elevation	T2 Elevation	T1 Flow	T2 Flow
	349.85 ft	349.98 ft	4.90 ft ³ /s	5.49 ft ³ /s

Subsection: Outlet Input Data
Label: Blo 6

Return Event: 1 years
Storm Event: 1-Year

Structure ID: TW1	
Structure Type: TW Setup, DS Channel	
Tailwater Type	Free Outfall
Convergence Tolerances	
Maximum Iterations	30
Tailwater Tolerance (Minimum)	0.01 ft
Tailwater Tolerance (Maximum)	0.50 ft
Headwater Tolerance (Minimum)	0.01 ft
Headwater Tolerance (Maximum)	0.50 ft
Flow Tolerance (Minimum)	0.001 ft ³ /s
Flow Tolerance (Maximum)	10.000 ft ³ /s

Subsection: Individual Outlet Curves
Label: Bio 6

Return Event: 1 years
Storm Event: 1-Year

RATING TABLE FOR ONE OUTLET TYPE
Structure ID = User Defined Rating Table (User Defined Table)

Upstream ID = (Pond Water Surface)
Downstream ID = Culvert (Culvert-Circular)

Water Surface Elevation (ft)	Device Flow (ft ³ /s)	(ft)	Headwater Hydraulic Grade Line (ft)	(ft)	Converge Downstream Hydraulic Grade Line (ft)	Next Downstream Hydraulic Grade Line (ft)	Downstream Hydraulic Grade Line Error (ft)	Convergence Error (ft/s)	Downstream Channel Tailwater (ft)	Tailwater Error (ft)
348.50	0.00	0.00	0.00	0.00	0.00	0.00	0.00	0.00	(N/A)	0.00
349.00	0.05	349.00	348.62	348.62	0.00	348.62	0.00	0.00	(N/A)	0.00
349.50	0.05	349.50	348.62	348.62	0.00	348.62	0.00	0.00	(N/A)	0.00
350.00	0.05	350.00	348.62	348.62	0.00	348.62	0.00	0.00	(N/A)	0.00
350.50	0.05	350.50	348.62	348.62	0.00	348.62	0.00	0.00	(N/A)	0.00
351.00	0.05	351.00	348.62	348.62	0.00	348.62	0.00	0.00	(N/A)	0.00
351.50	0.05	351.50	348.62	348.62	0.00	348.62	0.00	0.00	(N/A)	0.00
352.00	0.05	352.00	348.62	348.62	0.00	348.62	0.00	0.00	(N/A)	0.00
352.50	0.05	352.50	352.50	352.50	0.00	352.50	0.00	0.00	(N/A)	0.00

Message:

WS below an Invert; no flow.
Interpolated from input table
Interpolated from input table
Interpolated from input table
Interpolated from input table
Interpolated from input table

Subsection: Individual Outlet Curves
Label: Bio 6

Return Event: 1 years
Storm Event: 1-Year

RATING TABLE FOR ONE OUTLET TYPE
Structure ID = Riser (Inlet Box)

Upstream ID = (Pond Water Surface)
Downstream ID = Culvert (Culvert-Circular)

Water Surface Elevation (ft)	Device Flow (ft ³ /s)	(ft)	Headwater Hydraulic Grade Line (ft)	(ft)	Converge Downstream Hydraulic Grade Line (ft)	Next Downstream Hydraulic Grade Line (ft)	Downstream Hydraulic Grade Line Error (ft)	Convergence Error (ft/s)	Downstream Channel Tailwater (ft)	Tailwater Error (ft)
348.50	0.00	0.00	0.00	0.00	0.00	0.00	0.00	0.00	(N/A)	0.00
349.00	0.00	0.00	0.00	0.00	0.00	348.62	0.00	0.00	(N/A)	0.00
349.50	0.00	0.00	0.00	0.00	0.00	348.62	0.00	0.00	(N/A)	0.00
350.00	0.00	0.00	0.00	0.00	0.00	348.62	0.00	0.00	(N/A)	0.00
350.50	0.00	0.00	0.00	0.00	0.00	348.62	0.00	0.00	(N/A)	0.00
351.00	0.00	0.00	0.00	0.00	0.00	348.62	0.00	0.00	(N/A)	0.00
351.50	0.00	0.00	0.00	0.00	0.00	348.62	0.00	0.00	(N/A)	0.00
352.00	0.00	0.00	0.00	0.00	0.00	348.62	0.00	0.00	(N/A)	0.00
352.50	15.97	352.50	352.50	352.50	0.00	352.50	0.00	0.00	(N/A)	0.00

Message:

WS below an Invert; no flow.
WS below an Invert; no flow.
WS below an Invert; no flow.
WS below an Invert; no flow.
WS below an Invert; no flow.
WS below an Invert; no flow.
WS below an Invert; no flow.
FULLY CHARGED RISER: ADJUSTED TO WEIR: H = 0.5ft.

Subsection: Individual Outlet Curves
Label: Blo 6

Return Event: 1 years
Storm Event: 1-Year

RATING TABLE FOR ONE OUTLET TYPE
Structure ID = Culvert (Culvert-Circular)

Manning's open channel maximum capacity: 10.62 ft³/s
Upstream ID = Riser, User Defined Rating Table
Downstream ID = Tailwater (Pond Outfall)

Water Surface Elevation (ft)	Device Flow (ft ² /s)	Headwater Hydraulic Grade Line (ft)	Converge Downstream Hydraulic Grade Line (ft)	Next Downstream Hydraulic Grade Line (ft)	Downstream Hydraulic Error (ft)	Downstream Channel Tailwater (ft)	Convergence Error (ft ² /s)	Downstream Tailwater Error (ft)	Tailwater Error (ft)
348.50	0.00	0.00	0.00	0.00	0.00	0.00	0.00	0.00	0.00
349.00	0.05	348.52	Free Outfall	Free Outfall	0.00	0.00	0.00	0.00	0.00
349.50	0.05	348.52	Free Outfall	Free Outfall	0.00	0.00	0.00	0.00	0.00
350.00	0.05	348.52	Free Outfall	Free Outfall	0.00	0.00	0.00	0.00	0.00
350.50	0.05	348.52	Free Outfall	Free Outfall	0.00	0.00	0.00	0.00	0.00
351.00	0.05	348.52	Free Outfall	Free Outfall	0.00	0.00	0.00	0.00	0.00
351.50	0.05	348.52	Free Outfall	Free Outfall	0.00	0.00	0.00	0.00	0.00
352.00	0.05	348.52	Free Outfall	Free Outfall	0.00	0.00	0.00	0.00	0.00
352.50	10.84	352.50	Free Outfall	Free Outfall	0.00	6.18	6.18	0.00	0.00

Message:
WS below an invert: no flow.
CRIT. DEPTH CONTROL Vh= .029ft
Dcr=.085ft CRIT.DEPTH Hey=.00ft
CRIT. DEPTH CONTROL Vh=.029ft
Dcr=.085ft CRIT. DEPTH Hey=.00ft
CRIT. DEPTH CONTROL Vh=.029ft
Dcr=.085ft CRIT. DEPTH Hey=.00ft
CRIT. DEPTH CONTROL Vh=.029ft
Dcr=.085ft CRIT. DEPTH Hey=.00ft
CRIT. DEPTH CONTROL Vh=.029ft
Dcr=.085ft CRIT. DEPTH Hey=.00ft
CRIT. DEPTH CONTROL Vh=.029ft
Dcr=.085ft CRIT. DEPTH Hey=.00ft
CRIT. DEPTH CONTROL Vh=.029ft
Dcr=.085ft CRIT. DEPTH Hey=.00ft
FULL FLOW...Lfull=270.64ft
Vh=1.212ft Hl=9.075ft Hey=.00ft

Composite Outflow Summary

Water Surface Elevation (ft)	Flow (ft ² /s)	Tailwater Elevation (ft)	Convergence Error (ft)
348.50	0.00	(N/A)	0.00
349.00	0.05	(N/A)	0.00
349.50	0.05	(N/A)	0.00
350.00	0.05	(N/A)	0.00
350.50	0.05	(N/A)	0.00
351.00	0.05	(N/A)	0.00
351.50	0.05	(N/A)	0.00
352.00	0.05	(N/A)	0.00
352.50	10.84	(N/A)	0.00

Contributing Structures
(no Q: Riser; User Defined Rating Table; Culvert)
(no Q: Riser; User Defined Rating Table; Culvert)
(no Q: Riser; User Defined Rating Table; Culvert)
(no Q: Riser; User Defined Rating Table; Culvert)
(no Q: Riser; User Defined Rating Table; Culvert)
(no Q: Riser; User Defined Rating Table; Culvert)
(no Q: Riser; User Defined Rating Table; Culvert)
(no Q: Riser; User Defined Rating Table; Culvert)
(no Q: Riser; User Defined Rating Table; Culvert)
(no Q: Riser; User Defined Rating Table; Culvert)
(no Q: Riser; User Defined Rating Table; Culvert)
(no Q: Riser; User Defined Rating Table; Culvert)
(no Q: Riser; User Defined Rating Table; Culvert)

Subsection: Outlet Input Data
Label: Pond

Return Event: 1 years
Storm Event: 1-Year

Requested Pond Water Surface Elevations	
Minimum (Headwater)	337.00 ft
Increment (Headwater)	0.50 ft
Maximum (Headwater)	347.00 ft

Outlet Connectivity

Structure Type	Outlet ID	Direction	Outfall	E1 (ft)	E2 (ft)
Orifice-Area	Orifice - 2	Forward	Culvert	344.17	347.00
Inlet Box	Riser	Forward	Culvert	346.00	347.00
Orifice-Circular	Orifice	Forward	Culvert	341.00	347.00
Culvert-Circular	Culvert	Forward	TV	337.00	347.00
Tailwater Settings	Tailwater			(N/A)	(N/A)

Subsection: Outlet Input Data
Label: Pond

Return Event: 1 years
Storm Event: 1-Year

Structure ID: Orifice	
Structure Type: Orifice-Circular	
Number of Openings	1
Elevation	341.00 ft
Orifice Diameter	3.7 in
Orifice Coefficient	0.600

Subsection: Outlet Input Data
Label: Pond

Return Event: 1 years
Storm Event: 1-Year

Structure ID: Culvert	
Structure Type: Culvert-Circular	1
Diameter	24.0 in
Length	75.00 ft
Length (Computed Barrel)	75.02 ft
Slope (Computed)	0.024 ft/ft
Outlet Control Data	
Manning's n	0.013
Ke	0.500
Kb	0.012
Kr	0.000
Convergence Tolerance	0.00 ft

Inlet Control Data	
Equation Form	Form 1
K	0.0098
M	2.0000
C	0.0098
Y	0.6700
T1 ratio (HW/D)	1.148
T2 ratio (HW/D)	1.295
Slope Correction Factor	-0.500

Use unsubmerged inlet control O equation below T1 elevation.
Use submerged inlet control O equation above T2 elevation.

In transition zone between unsubmerged and submerged inlet control interpolate between flows at T1 & T2...

T1 Elevation	339.30 ft	T1 Flow	15.55 ft ³ /s
T2 Elevation	339.59 ft	T2 Flow	17.77 ft ³ /s

Subsection: Outlet Input Data
Label: Pond

Return Event: 1 years
Storm Event: 1-Year

Structure ID: Riser	
Structure Type: Inlet Box	1
Number of Openings	346.00 ft
Elevation	16.0 ft
Orifice Area	0.600
Orifice Coefficient	16.00 ft
Weir Length	3.00 (ft*0.5)/s
Weir Coefficient	1.000
K Reverse	0.000
Manning's n	0.000
Key, Changed Riser	0.000
Weir Submergence	False
Orifice H to crest	False

Structure ID: Orifices - 2	
Structure Type: Orifices-Area	
Number of Openings	
Elevation	344.17 ft
Orifice Area	3.6 ft ²
Top Elevation	345.43 ft
Datum Elevation	344.18 ft
Orifice Coefficient	0.600

Structure ID: TV	
Structure Type: TV/ Setup, DS Channel	
Tailwater Type: Free Outfall	
Convergence Tolerances	
Maximum Iterations	30
Tailwater Tolerance (Minimum)	0.01 ft
Tailwater Tolerance (Maximum)	0.50 ft
Headwater Tolerance (Minimum)	0.01 ft
Headwater Tolerance (Maximum)	0.50 ft
Flow Tolerance (Minimum)	0.001 ft ³ /s
Flow Tolerance (Maximum)	10.000 ft ³ /s

Subsection: Individual Outlet Curves
 Label: Pond

Return Event: 1 years
 Storm Event: 1-Year

RATING TABLE FOR ONE OUTLET TYPE
 Structure ID = Orifice (Orifice-Circular)

Upstream ID = (Pond Water Surface)
 Downstream ID = Culvert (Culvert-Circular)

Water Surface Elevation (ft)	Device Flow (cfs)	Convergence Hydraulic Grade Line (ft)	Convergence Hydraulic Grade Line Error (ft)	Downstream Hydraulic Grade Line (ft)	Downstream Hydraulic Grade Line Error (ft)	Downstream Channel Tailwater (ft)	Tailwater Error (ft)
337.00	0.00	0.00	0.00	0.00	0.00	(N/A)	0.00
337.50	0.00	0.00	0.00	0.00	0.00	(N/A)	0.00
338.00	0.00	0.00	0.00	0.00	0.00	(N/A)	0.00
338.50	0.00	0.00	0.00	0.00	0.00	(N/A)	0.00
339.00	0.00	0.00	0.00	0.00	0.00	(N/A)	0.00
339.50	0.00	0.00	0.00	0.00	0.00	(N/A)	0.00
340.00	0.00	0.00	0.00	0.00	0.00	(N/A)	0.00
340.50	0.00	0.00	0.00	0.00	0.00	(N/A)	0.00
341.00	0.00	0.00	0.00	0.00	0.00	(N/A)	0.00
341.50	0.21	341.50	Free Outfall	337.24	0.00	(N/A)	0.00
342.00	0.33	342.00	Free Outfall	0.00	0.00	(N/A)	0.00
342.50	0.42	342.50	Free Outfall	337.33	0.00	(N/A)	0.00
343.00	0.49	343.00	Free Outfall	337.36	0.00	(N/A)	0.00
343.50	0.55	343.50	Free Outfall	0.00	0.00	(N/A)	0.00
344.00	0.61	344.00	Free Outfall	337.40	0.00	(N/A)	0.00
344.17	0.62	344.17	Free Outfall	0.00	0.00	(N/A)	0.00
344.50	0.66	344.50	Free Outfall	338.35	0.00	(N/A)	0.00
345.00	0.70	345.00	Free Outfall	339.25	0.00	(N/A)	0.00
345.50	0.75	345.50	Free Outfall	340.18	0.00	(N/A)	0.00
346.00	0.79	346.00	Free Outfall	340.86	0.00	(N/A)	0.00
346.50	0.46	346.50	344.89	344.89	0.00	(N/A)	0.00
347.00	0.00	347.00	347.00	347.00	0.00	(N/A)	0.00

Message:

- WS below an invert; no flow.
- WS below an invert; no flow.
- WS below an invert; no flow.
- WS below an invert; no flow.
- WS below an invert; no flow.
- WS below an invert; no flow.
- WS below an invert; no flow.
- WS below an invert; no flow.
- H = .25
- H = .85
- H = 1.35
- H = 1.85
- H = 2.35
- H = 2.85
- H = 3.02
- H = 3.35
- H = 3.85
- H = 4.35
- H = 4.85

model3.ppc
 3/5/2014

Subsection: Individual Outlet Curves
 Label: Pond

Return Event: 1 years
 Storm Event: 1-Year

RATING TABLE FOR ONE OUTLET TYPE
 Structure ID = Orifice (Orifice-Circular)

Upstream ID = (Pond Water Surface)
 Downstream ID = Culvert (Culvert-Circular)

H = 1.61	Message
FLOW PRECEDENCE SET TO DOWNSTREAM CONTROLLING STRUCTURE	

model3.ppc
 3/5/2014

Subsection: Individual Outlet Curves
Label: Pond

Return Event: 1 years
Storm Event: 1-Year

RATING TABLE FOR ONE OUTLET TYPE
Structure ID = Riser (Inlet Box)

Upstream ID = (Pond Water Surface)
Downstream ID = Culvert (Culvert-Circular)

Water Surface Elevation (ft)	Device Flow (ft ³ /s)	Into Headwater Hydraulic Grade Line (ft)	Converge Downstream Hydraulic Grade Line (ft)	Next Downstream Hydraulic Grade Line (ft)	Downstream Hydraulic Grade Line Error (ft)	Convergence Error (ft/s)	Downstream Channel Tailwater (ft)	Tailwater Error (ft)
337.00	0.00	0.00	0.00	0.00	0.00	0.00	(N/A)	0.00
337.50	0.00	0.00	0.00	0.00	0.00	0.00	(N/A)	0.00
338.00	0.00	0.00	0.00	0.00	0.00	0.00	(N/A)	0.00
338.50	0.00	0.00	0.00	0.00	0.00	0.00	(N/A)	0.00
339.00	0.00	0.00	0.00	0.00	0.00	0.00	(N/A)	0.00
339.50	0.00	0.00	0.00	0.00	0.00	0.00	(N/A)	0.00
340.00	0.00	0.00	0.00	0.00	0.00	0.00	(N/A)	0.00
340.50	0.00	0.00	0.00	0.00	0.00	0.00	(N/A)	0.00
341.00	0.00	0.00	0.00	0.00	0.00	0.00	(N/A)	0.00
341.50	0.00	0.00	0.00	337.24	0.00	0.00	(N/A)	0.00
342.00	0.00	0.00	0.00	0.00	0.00	0.00	(N/A)	0.00
342.50	0.00	0.00	0.00	337.33	0.00	0.00	(N/A)	0.00
343.00	0.00	0.00	0.00	337.36	0.00	0.00	(N/A)	0.00
343.50	0.00	0.00	0.00	0.00	0.00	0.00	(N/A)	0.00
344.00	0.00	0.00	0.00	337.40	0.00	0.00	(N/A)	0.00
344.17	0.00	0.00	0.00	0.00	0.00	0.00	(N/A)	0.00
344.50	0.00	0.00	0.00	338.35	0.00	0.00	(N/A)	0.00
345.00	0.00	0.00	0.00	339.25	0.00	0.00	(N/A)	0.00
345.50	0.00	0.00	0.00	340.18	0.00	0.00	(N/A)	0.00
346.00	0.00	0.00	0.00	340.86	0.00	0.00	(N/A)	0.00
346.50	16.97	346.50	Free Outfall	344.89	0.00	0.00	(N/A)	0.00
347.00	48.00	347.00	347.00	347.00	0.00	0.00	(N/A)	0.00

Message:

WS below an invert; no flow.
WS below an invert; no flow.
WS below an invert; no flow.
WS below an invert; no flow.
WS below an invert; no flow.
WS below an invert; no flow.
WS below an invert; no flow.
WS below an invert; no flow.
WS below an invert; no flow.
WS below an invert; no flow.
WS below an invert; no flow.
WS below an invert; no flow.
WS below an invert; no flow.
WS below an invert; no flow.
WS below an invert; no flow.
WS below an invert; no flow.
WS below an invert; no flow.
WS below an invert; no flow.
WS below an invert; no flow.
WS below an invert; no flow.

Subsection: Individual Outlet Curves
Label: Pond

Return Event: 1 years
Storm Event: 1-Year

RATING TABLE FOR ONE OUTLET TYPE
Structure ID = Riser (Inlet Box)

Upstream ID = (Pond Water Surface)
Downstream ID = Culvert (Culvert-Circular)

Message:
Weir H = 0.5ft
FULLY CHARGED RISER: ADJUSTED TO
WEIR: H = 1ft

Subsection: Individual Outlet Curves
Label: Pond

Return Event: 1 years
Storm Event: 1-Year

RATING TABLE FOR ONE OUTLET TYPE
Structure ID = Orifice - 2 (Office-Area)

Upstream ID = (Pond Water Surface)
Downstream ID = Culvert (Culvert-Circular)

Water Surface Elevation (ft)	Device Flow (ft ³ /s)	(Into) Headwater Hydraulic Grade Line (ft)	Converge Downstream Hydraulic Grade Line (ft)	Next Downstream Hydraulic Grade Line (ft)	Downstream Hydraulic Grade Line Error (ft)	Convergence Error (ft ³ /s)	Downstream Channel Tailwater (ft)	Tailwater Error (ft)
337.00	0.00	0.00	0.00	0.00	0.00	0.00	(N/A)	0.00
337.50	0.00	0.00	0.00	0.00	0.00	0.00	(N/A)	0.00
338.00	0.00	0.00	0.00	0.00	0.00	0.00	(N/A)	0.00
338.50	0.00	0.00	0.00	0.00	0.00	0.00	(N/A)	0.00
339.00	0.00	0.00	0.00	0.00	0.00	0.00	(N/A)	0.00
339.50	0.00	0.00	0.00	0.00	0.00	0.00	(N/A)	0.00
340.00	0.00	0.00	0.00	0.00	0.00	0.00	(N/A)	0.00
340.50	0.00	0.00	0.00	0.00	0.00	0.00	(N/A)	0.00
341.00	0.00	0.00	0.00	0.00	0.00	0.00	(N/A)	0.00
341.50	0.00	0.00	0.00	337.24	0.00	0.00	(N/A)	0.00
342.00	0.00	0.00	0.00	0.00	0.00	0.00	(N/A)	0.00
342.50	0.00	0.00	0.00	337.33	0.00	0.00	(N/A)	0.00
343.00	0.00	0.00	0.00	337.36	0.00	0.00	(N/A)	0.00
343.50	0.00	0.00	0.00	0.00	0.00	0.00	(N/A)	0.00
344.00	0.00	0.00	0.00	337.40	0.00	0.00	(N/A)	0.00
344.17	0.00	0.00	0.00	0.00	0.00	0.00	(N/A)	0.00
344.50	5.29	344.50	Free Outfall	338.35	0.00	0.00	(N/A)	0.00
345.00	12.29	345.00	Free Outfall	339.25	0.00	0.00	(N/A)	0.00
345.50	20.74	345.50	Free Outfall	340.18	0.00	0.00	(N/A)	0.00
346.00	24.35	346.00	Free Outfall	340.86	0.00	0.00	(N/A)	0.00
346.50	22.92	346.50	344.99	344.89	0.00	0.00	(N/A)	0.00
347.00	0.00	347.00	347.00	347.00	0.00	0.00	(N/A)	0.00

Message

- WS below an invert; no flow.
- WS below an invert; no flow.
- WS below an invert; no flow.
- WS below an invert; no flow.
- WS below an invert; no flow.
- WS below an invert; no flow.
- WS below an invert; no flow.
- WS below an invert; no flow.
- WS below an invert; no flow.
- WS below an invert; no flow.
- WS below an invert; no flow.
- WS below an invert; no flow.
- WS below an invert; no flow.
- WS below an invert; no flow.
- WS below an invert; no flow.
- WS below an invert; no flow.
- WS below an invert; no flow.
- WS below an invert; no flow.
- WS below an invert; no flow.
- WS below an invert; no flow.
- HS=-33; HT=1.25; QT=20.18
- HS=-83; HT=1.25; QT=20.18
- H = 1.32
- H = 1.82

model3.ppc
3/5/2014

Bentley PondPack V8i
[08/11/01/50]
Page 175 of 203

Bentley Systems, Inc. Harbort Methods Solution Center
27 Siemon Company Drive Suite 200 W. Watertown, CT
06705 USA +1-503-755-1699

Subsection: Individual Outlet Curves
Label: Pond

Return Event: 1 years
Storm Event: 1-Year

RATING TABLE FOR ONE OUTLET TYPE
Structure ID = Orifice - 2 (Office-Area)

Upstream ID = (Pond Water Surface)
Downstream ID = Culvert (Culvert-Circular)

Message
H = 1.61
FLOW PRECEDENCE SET TO DOWNSTREAM CONTROLLING STRUCTURE

model3.ppc
3/5/2014

Bentley Systems, Inc. Harbort Methods Solution Center
27 Siemon Company Drive Suite 200 W. Watertown, CT
06705 USA +1-503-755-1699

Bentley PondPack V8i
[08/11/01/50]
Page 176 of 203

Subsection: Composite Rating Curve
 Label: Pond
 Return Event: 1 years
 Storm Event: 1-Year

Composite Outflow Summary

Water Surface Elevation (ft)	Flow (cfs)	Tailwater Elevation (ft)	Convergence Error (ft)
337.00	0.00	(N/A)	0.00
337.50	0.00	(N/A)	0.00
338.00	0.00	(N/A)	0.00
338.50	0.00	(N/A)	0.00
339.00	0.00	(N/A)	0.00
339.50	0.00	(N/A)	0.00
340.00	0.00	(N/A)	0.00
340.50	0.00	(N/A)	0.00
341.00	0.00	(N/A)	0.00
341.50	0.21	(N/A)	0.00
342.00	0.33	(N/A)	0.00
342.50	0.42	(N/A)	0.00
343.00	0.49	(N/A)	0.00
343.50	0.55	(N/A)	0.00
344.00	0.61	(N/A)	0.00
344.17	0.62	(N/A)	0.00
344.50	5.94	(N/A)	0.00
345.00	14.00	(N/A)	0.00
345.50	21.48	(N/A)	0.00
346.00	25.14	(N/A)	0.00
346.50	40.36	(N/A)	0.00
347.00	46.41	(N/A)	0.00

Contributing Structures

- (no Q); Orifice -
- 2,Riser,Orifice,Culvert
- (no Q); Orifice -
- 2,Riser,Orifice,Culvert
- (no Q); Orifice -
- 2,Riser,Orifice,Culvert
- (no Q); Orifice -
- 2,Riser,Orifice,Culvert
- (no Q); Orifice -
- 2,Riser,Orifice,Culvert
- (no Q); Orifice -
- 2,Riser,Orifice,Culvert
- (no Q); Orifice -
- 2,Riser,Orifice,Culvert
- (no Q); Orifice -
- 2,Riser,Orifice,Culvert
- (no Q); Orifice -
- 2,Riser,Orifice,Culvert
- (no Q); Orifice -
- 2,Riser,Orifice,Culvert
- (no Q); Orifice -
- 2,Riser,Orifice,Culvert
- (no Q); Orifice -
- 2,Riser,Orifice,Culvert
- (no Q); Orifice -
- 2,Riser,Orifice,Culvert
- (no Q); Orifice -
- 2,Riser,Orifice,Culvert
- (no Q); Orifice -
- 2,Riser,Orifice,Culvert
- (no Q); Orifice -
- 2,Riser,Orifice,Culvert
- (no Q); Orifice -
- 2,Riser,Orifice,Culvert
- (no Q); Orifice -
- 2,Riser,Orifice,Culvert
- (no Q); Orifice -
- 2,Riser,Orifice,Culvert
- (no Q); Orifice -
- 2,Riser,Orifice,Culvert
- (no Q); Orifice -
- 2,Riser,Orifice,Culvert

Subsection: Composite Rating Curve
 Label: Pond
 Return Event: 1 years
 Storm Event: 1-Year

Composite Outflow Summary

- Contributing Structures
- Orifice,Culvert (no Q); Orifice -
- 2,Riser
- Orifice,Culvert (no Q); Orifice -
- 2,Riser
- Orifice - 2,Orifice,Culvert (no Q);
- Riser
- Orifice - 2,Orifice,Culvert (no Q);
- Riser
- Orifice - 2,Orifice,Culvert (no Q);
- Riser
- Orifice - 2,Orifice,Culvert (no Q);
- Riser
- Orifice - 2,Orifice,Culvert (no Q);
- Riser,Orifice,Culvert
- Riser,Culvert (no Q); Orifice -
- 2,Orifice

Subsection: Outlet Input Data
Label: PP 1,5

Return Event: 1 years
Storm Event: 1-Year

Requested Pond Water Surface Elevations	
Minimum (Headwater)	348.72 ft
Increment (Headwater)	0.50 ft
Maximum (Headwater)	353.22 ft

Outlet Connectivity

Structure Type	Outlet ID	Direction	Outfall	E1 (ft)	E2 (ft)
Inlet Box	Riser	Forward	Culvert	352.72	353.22
Orifice-Circular	Orifice	Forward	Culvert	350.05	353.22
Culvert-Circular	Culvert	Forward	TW	350.05	353.22
Tailwater Settings	Tailwater			(N/A)	(N/A)

Subsection: Outlet Input Data
Label: PP 1,5

Return Event: 1 years
Storm Event: 1-Year

Structure ID: Orifice	
Structure Type: Orifice-Circular	
Number of Openings	1
Elevation	350.05 ft
Orifice Diameter	6.0 in
Orifice Coefficient	0.600

Subsection: Outlet Input Data
Label: PP 1,5

Return Event: 1 years
Storm Event: 1-Year

Structure ID: Culvert	
Structure Type: Culvert-Circular	
Number of Barrels	1
Diameter	15.0 in
Length	54.00 ft
Length (Computed Barrel)	54.09 ft
Slope (Computed)	0.056 ft/ft
Outlet Control Data	
Manning's n	0.013
Ke	0.200
Kb	0.023
Kr	0.000
Convergence Tolerance	0.00 ft

Inlet Control Data	
Equation Form	Form 1
K	0.0045
M	2.0000
C	0.0317
Y	0.6900
T1 ratio (HW/D)	1.067
T2 ratio (HW/D)	1.169
Slope Correction Factor	-0.500

Use unsubmerged inlet control 0 equation below T1 elevation.

Use submerged inlet control 0 equation above T2 elevation

In transition zone between unsubmerged and submerged inlet control

interpolate between flows at T1 & T2...

T1 Elevation	351.38 ft	T1 Flow	4.80 ft ³ /s
T2 Elevation	351.51 ft	T2 Flow	5.49 ft ³ /s

Subsection: Outlet Input Data
Label: PP 1,5

Return Event: 1 years
Storm Event: 1-Year

Structure ID: Riser	
Structure Type: Inlet Box	
Number of Openings	1
Elevation	352.72 ft
Orifice Area	10.0 ft ²
Orifice Coefficient	0.600
Weir Length	13.00 ft
Weir Coefficient	3.00 (ft ^{0.5} /s)
K Reverse	1.000
Manning's n	0.000
Key, Changed Riser	0.000
Weir Submergence	False
Orifice H to crest	False

Structure ID: TW	
Structure Type: TW Setup, DS Channel	
Tailwater Type	Free Outfall
Convergence Tolerances	
Maximum Iterations	30
Tailwater Tolerance (Minimum)	0.01 ft
Tailwater Tolerance (Maximum)	0.50 ft
Headwater Tolerance (Minimum)	0.01 ft
Headwater Tolerance (Maximum)	0.50 ft
Flow Tolerance (Minimum)	0.001 ft ³ /s
Flow Tolerance (Maximum)	10.000 ft ³ /s

Subsection: Individual Outlet Curves
Label: PP 1,5

Return Event: 1 years
Storm Event: 1-Year

RATING TABLE FOR ONE OUTLET TYPE
Structure ID = Orifice (Orifice-Circular)

Downstream ID = (Pond Water Surface)
Upstream ID = Orifice (Orifice-Circular)

Water Surface Elevation (ft)	Device Flow (ft ³ /s)	Into		Converge		Downstream		Next		Downstream		Tailwater	
		Headwater Hydraulic Grade Line (ft)	Headwater Hydraulic Grade Line (ft)	Downstream Hydraulic Grade Line (ft)	Converge Hydraulic Grade Line (ft)	Downstream Hydraulic Grade Line (ft)	Downstream Hydraulic Grade Line (ft)	Downstream Hydraulic Grade Line (ft)	Downstream Hydraulic Grade Line (ft)	Downstream Hydraulic Grade Line (ft)	Downstream Hydraulic Grade Line (ft)	Downstream Channel Tailwater (ft)	Tailwater Error (ft)
348.72	0.00	0.00	0.00	0.00	0.00	0.00	0.00	0.00	0.00	0.00	(N/A)	0.00	
349.72	0.00	0.00	0.00	0.00	0.00	0.00	0.00	0.00	0.00	0.00	(N/A)	0.00	
350.05	0.00	0.00	0.00	0.00	0.00	0.00	0.00	0.00	0.00	0.00	(N/A)	0.00	
350.22	0.06	350.22	350.18	350.18	0.00	0.00	0.00	0.00	0.00	0.00	(N/A)	0.00	
350.72	0.50	350.72	350.44	350.44	0.00	0.00	0.00	0.00	0.00	0.00	(N/A)	0.00	
351.22	0.78	351.22	350.54	350.54	0.00	0.00	0.00	0.00	0.00	0.00	(N/A)	0.00	
351.72	0.99	351.72	350.61	350.61	0.00	0.00	0.00	0.00	0.00	0.00	(N/A)	0.00	
352.22	1.18	352.22	350.67	350.67	0.00	0.00	0.00	0.00	0.00	0.00	(N/A)	0.00	
352.72	1.34	352.72	350.71	350.71	0.00	0.00	0.00	0.00	0.00	0.00	(N/A)	0.00	
353.22	0.00	353.22	353.22	353.22	0.00	0.00	0.00	0.00	0.00	0.00	(N/A)	0.00	

Message
WS below an invert; no flow.
WS below an invert; no flow.
WS below an invert; no flow.
BACKWATER CONTROL... Vh = .043ft
hwDI = .126ft Lbw = .0ft Hw = .00ft
H = .28
H = .68
H = 1.11
H = 1.55
H = 2.01
FLOW PREFERENCE SET TO
DOWNSTREAM CONTROLLING
STRUCTURE

Subsection: Individual Outlet Curves
Label: PP 1,5

Return Event: 1 years
Storm Event: 1-Year

RATING TABLE FOR ONE OUTLET TYPE
Structure ID = Culvert (Culvert-Circular)

Mannings open channel maximum capacity: 16.51 ft³/s
Upstream ID = Riser, Orifice
Downstream ID = Tailwater (Pond Outfall)

Water Surface Elevation (ft)	Device Flow (ft ³ /s)	Into		Converge		Downstream		Next		Downstream		Tailwater	
		Headwater Hydraulic Grade Line (ft)	Headwater Hydraulic Grade Line (ft)	Downstream Hydraulic Grade Line (ft)	Converge Hydraulic Grade Line (ft)	Downstream Hydraulic Grade Line (ft)	Downstream Hydraulic Grade Line (ft)	Downstream Hydraulic Grade Line (ft)	Downstream Hydraulic Grade Line (ft)	Downstream Channel Tailwater (ft)	Tailwater Error (ft)		
348.72	0.00	0.00	0.00	0.00	0.00	0.00	0.00	0.00	0.00	0.00	(N/A)	0.00	
349.72	0.00	0.00	0.00	0.00	0.00	0.00	0.00	0.00	0.00	0.00	(N/A)	0.00	
349.72	0.00	0.00	0.00	0.00	0.00	0.00	0.00	0.00	0.00	0.00	(N/A)	0.00	
350.05	0.00	0.00	0.00	0.00	0.00	0.00	0.00	0.00	0.00	0.00	(N/A)	0.00	
350.22	0.06	350.22	350.18	350.18	Free Outfall	Free Outfall	0.00	0.00	0.00	0.00	(N/A)	0.00	
350.72	0.50	350.72	350.44	350.44	Free Outfall	Free Outfall	0.00	0.00	0.00	0.00	(N/A)	0.00	
351.22	0.78	351.22	350.54	350.54	Free Outfall	Free Outfall	0.00	0.00	0.00	0.00	(N/A)	0.00	
351.72	0.99	351.72	350.61	350.61	Free Outfall	Free Outfall	0.00	0.00	0.00	0.00	(N/A)	0.00	
352.22	1.17	352.22	350.67	350.67	Free Outfall	Free Outfall	0.00	0.00	0.00	0.00	(N/A)	0.00	
352.72	1.34	352.72	350.71	350.71	Free Outfall	Free Outfall	0.00	0.00	0.00	0.00	(N/A)	0.00	
353.22	0.00	353.22	353.22	353.22	Free Outfall	Free Outfall	0.00	0.00	0.00	3.24	(N/A)	0.00	

Message
WS below an invert; no flow.
WS below an invert; no flow.
WS below an invert; no flow.
WS below an invert; no flow.
CRIT DEPTH CONTROL Vh = .031ft
Dcr = .090ft CRIT DEPTH Hw = .00ft
CRIT DEPTH CONTROL Vh = .096ft
Dcr = .275ft CRIT DEPTH Hw = .00ft
CRIT DEPTH CONTROL Vh = .123ft
Dcr = .345ft CRIT DEPTH Hw = .00ft
CRIT DEPTH CONTROL Vh = .142ft
Dcr = .392ft CRIT DEPTH Hw = .00ft
CRIT DEPTH CONTROL Vh = .156ft
Dcr = .427ft CRIT DEPTH Hw = .00ft
FLOW PREFERENCE SET TO
UPSTREAM CONTROLLING
STRUCTURE
INLET CONTROL... Submerged: HW
= 3.17

Subsection: Individual Outlet Curves
Label: PP 1,5

Return Event: 1 Years
Storm Event: 1-Year

RATING TABLE FOR ONE OUTLET TYPE
Structure ID = Riser (Inlet Box)

Upstream ID = (Pond Water Surface)
Downstream ID = Culvert (Culvert-Circular)

Water Surface Elevation (ft)	Device Flow (ft ³ /s)	Inlet Hydraulic Grade Line (ft)	Converge Downstream Hydraulic Grade Line (ft)	Downstream Hydraulic Grade Line (ft)	Next Downstream Hydraulic Grade Line (ft)	Downstream Hydraulic Grade Line Error (ft)	Convergence Error (ft%)	Downstream Channel Tailwater (ft)	Tailwater Error (ft)
348.72	0.00	0.00	0.00	0.00	0.00	0.00	0.00	(N/A)	0.00
349.72	0.00	0.00	0.00	0.00	0.00	0.00	0.00	(N/A)	0.00
350.05	0.00	0.00	0.00	0.00	0.00	0.00	0.00	(N/A)	0.00
350.22	0.00	0.00	0.00	0.00	350.18	0.00	0.00	(N/A)	0.00
350.72	0.00	0.00	0.00	0.00	350.44	0.00	0.00	(N/A)	0.00
351.22	0.00	0.00	0.00	0.00	350.54	0.00	0.00	(N/A)	0.00
351.72	0.00	0.00	0.00	0.00	350.61	0.00	0.00	(N/A)	0.00
352.22	0.00	0.00	0.00	0.00	350.67	0.00	0.00	(N/A)	0.00
352.72	0.00	0.00	0.00	0.00	350.71	0.00	0.00	(N/A)	0.00
353.22	13.79	353.22	353.22	353.22	353.22	0.00	0.00	(N/A)	0.00

Missage
WS below an invert: no flow.
WS below an invert: no flow.
WS below an invert: no flow.
WS below an invert: no flow.
WS below an invert: no flow.
WS below an invert: no flow.
WS below an invert: no flow.
WS below an invert: no flow.
WS below an invert: no flow.
WS below an invert: no flow.
WS below an invert: no flow.
FULLY CHARGED RISER: ADJUSTED TO WEIR: H = 0.5ft

Subsection: Composite Rating Curve
Label: PP 1,5

Return Event: 1 Years
Storm Event: 1-Year

Composite Outflow Summary

Water Surface Elevation (ft)	Flow (ft ³ /s)	Tailwater Elevation (ft)	Convergence Error (ft)
348.72	0.00	(N/A)	0.00
349.72	0.00	(N/A)	0.00
350.05	0.00	(N/A)	0.00
350.22	0.06	(N/A)	0.00
350.72	0.50	(N/A)	0.00
351.22	0.78	(N/A)	0.00
351.72	0.99	(N/A)	0.00
352.22	1.18	(N/A)	0.00
352.72	1.34	(N/A)	0.00
353.22	10.55	(N/A)	0.00

Contributing Structures

(no Q): Riser,Orifice,Culvert
(no Q): Riser,Orifice,Culvert
(no Q): Riser,Orifice,Culvert
Orifice,Culvert (no Q): Riser
Orifice,Culvert (no Q): Riser
Orifice,Culvert (no Q): Riser
Orifice,Culvert (no Q): Riser
Orifice,Culvert (no Q): Riser
Riser,Culvert (no Q): Orifice

Subsection: Outlet Input Data
Label: PP 2,3,4

Return Event: 1 years
Storm Event: 1-Year

Requested Pond Water Surface Elevations	
Minimum (Headwater)	348.60 ft
Increment (Headwater)	0.50 ft
Maximum (Headwater)	353.10 ft

Outlet Connectivity

Structure Type	Outlet ID	Direction	Outfall	E1 (ft)	E2 (ft)
Inlet Box	Riser	Forward	Culvert	352.60	353.10
Orifice-Circular	Orifice	Forward	Culvert	349.93	353.10
Culvert-Circular	Culvert	Forward	TW	349.93	353.10
Tailwater Settings	Tailwater			(N/A)	(N/A)

Subsection: Outlet Input Data
Label: PP 2,3,4

Return Event: 1 years
Storm Event: 1-Year

Structure ID: Orifice	
Structure Type: Orifice-Circular	
Number of Openings	1
Elevation	349.93 ft
Orifice Diameter	6.0 in
Orifice Coefficient	0.600

Subsection: Outlet Input Data
Label: PP 2,3,4

Return Event: 1 years
Storm Event: 1-Year

Structure ID: Culvert	
Structure Type: Culvert-Circular	1
Number of Barrels	15.0 in
Diameter	171.00 ft
Length	171.03 ft
Length (Computed Barrel)	0.017 ft/ft
Slope (Computed)	
Outlet Control Data	
Manning's n	0.013
Kc	0.200
Kb	0.023
Kr	0.000
Convergence Tolerance	0.00 ft
Inlet Control Data	
Equation Form	Form 1
K	0.0045
M	2.0000
C	0.0317
Y	0.6900
T1 ratio (HW/D)	1.087
T2 ratio (HW/D)	1.189
Slope Correction Factor	-0.500

Use unsubmerged inlet control 0 equation below T1 elevation.
Use submerged inlet control 0 equation above T2 elevation.

In transition zone between unsubmerged and submerged inlet control, interpolate between flows at T1 & T2....

T1 Elevation	351.29 ft	T1 Flow	4.80 ft ³ /s
T2 Elevation	351.42 ft	T2 Flow	5.49 ft ³ /s

Subsection: Outlet Input Data
Label: PP 2,3,4

Return Event: 1 years
Storm Event: 1-Year

Structure ID: Risler	
Structure Type: Inlet Box	1
Number of Openings	352.60 ft
Elevation	10.0 ft ²
Orifice Area	0.600
Orifice Coefficient	13.00 ft
Weir Length	3.00 (ft*(0.5)/s)
Weir Coefficient	1.000
K Reverse	0.000
Manning's n	0.000
Key, Charged Risler	0.000
Weir Submergence	False
Orifice H to crest	False
Structure ID: TW	
Structure Type: TW Setup, DS Channel	
Tailwater Type: Free Outfall	
Convergence Tolerances	
Maximum Iterations	30
Tailwater Tolerance (Minimum)	0.01 ft
Tailwater Tolerance (Maximum)	0.50 ft
Headwater Tolerance (Minimum)	0.01 ft
Headwater Tolerance (Maximum)	0.50 ft
Flow Tolerance (Minimum)	0.001 ft ³ /s
Flow Tolerance (Maximum)	10.000 ft ³ /s

Subsection: Individual Outlet Curves
Label: PP 2,3,4

Return Event: 1 Years
Storm Event: 1-Year

RATING TABLE FOR ONE OUTLET TYPE
Structure ID = Orifice (Orifice-Circular)

Upstream ID = (Pond Water Surface)
Downstream ID = Culvert (Culvert-Circular)

Water Surface Elevation (ft)	Device Flow (ft ³ /s)	(In) Headwater Hydraulic Grade Line (ft)	Converge Downstream Hydraulic Grade Line (ft)	Next Downstream Hydraulic Grade Line (ft)	Downstream Hydraulic Grade Line Error (ft)	Convergence Error (ft ² /s)	Downstream Channel Tailwater (ft)	Tailwater Error (ft)
348.60	0.00	0.00	0.00	0.00	0.00	0.00	(N/A)	0.00
349.10	0.00	0.00	0.00	0.00	0.00	0.00	(N/A)	0.00
349.60	0.00	0.00	0.00	0.00	0.00	0.00	(N/A)	0.00
349.93	0.00	0.00	0.00	0.00	0.00	0.00	(N/A)	0.00
350.10	0.06	350.10	350.06	350.06	0.00	0.00	(N/A)	0.00
350.60	0.50	350.60	350.32	350.32	0.00	0.00	(N/A)	0.00
351.10	0.78	351.10	350.42	350.42	0.00	0.00	(N/A)	0.00
351.60	0.99	351.60	350.49	350.49	0.00	0.00	(N/A)	0.00
352.10	1.18	352.10	350.54	350.54	0.00	0.00	(N/A)	0.00
352.60	1.34	352.60	350.59	350.59	0.00	0.00	(N/A)	0.00
353.10	0.00	353.10	353.10	353.10	0.00	0.00	(N/A)	0.00

Message

WS below an invert, no flow.
WS below an invert, no flow.
WS below an invert, no flow.
WS below an invert, no flow.
BACKWATER CONTROL, Vh= -0.43R
hw0= .126ft Lbw= .0ft Hw= .00ft
H = .28
H = .68
H = 1.11
H = 1.56
H = 2.01

FLOW PRECEDENCE SET TO
DOWNSTREAM CONTROLLING
STRUCTURE

Subsection: Individual Outlet Curves
Label: PP 2,3,4

Return Event: 1 Years
Storm Event: 1-Year

RATING TABLE FOR ONE OUTLET TYPE
Structure ID = Culvert (Culvert-Circular)

Manning's open channel maximum capacity: 9.10 ft³/s
Upstream ID = Riser, Orifice
Downstream ID = Tailwater (Pond Outfall)

Water Surface Elevation (ft)	Device Flow (ft ³ /s)	(In) Headwater Hydraulic Grade Line (ft)	Converge Downstream Hydraulic Grade Line (ft)	Next Downstream Hydraulic Grade Line (ft)	Downstream Hydraulic Grade Line Error (ft)	Convergence Error (ft ² /s)	Downstream Channel Tailwater (ft)	Tailwater Error (ft)
348.60	0.00	0.00	0.00	0.00	0.00	0.00	(N/A)	0.00
349.10	0.00	0.00	0.00	0.00	0.00	0.00	(N/A)	0.00
349.60	0.00	0.00	0.00	0.00	0.00	0.00	(N/A)	0.00
349.93	0.00	0.00	0.00	0.00	0.00	0.00	(N/A)	0.00
350.10	0.06	350.06	350.06	350.06	0.00	0.00	(N/A)	0.00
350.60	0.50	350.60	350.32	350.32	0.00	0.00	(N/A)	0.00
351.10	0.78	350.42	350.42	350.42	0.00	0.00	(N/A)	0.00
351.60	1.00	350.49	350.49	350.49	0.00	0.00	(N/A)	0.00
352.10	1.18	350.54	350.54	350.54	0.00	0.00	(N/A)	0.00
352.60	1.34	350.59	350.59	350.59	0.00	0.00	(N/A)	0.00
353.10	9.58	353.10	353.10	353.10	0.00	4.21	(N/A)	0.00

Message

WS below an invert, no flow.
WS below an invert, no flow.
WS below an invert, no flow.
WS below an invert, no flow.
CRIT.DEPH CONTROL Vh= .033ft
Dcr= .090ft CRIT.DEPH Hw= .00ft
CRIT.DEPH CONTROL Vh= .097ft
Dcr= .275ft CRIT.DEPH Hw= .00ft
CRIT.DEPH CONTROL Vh= .123ft
Dcr= .345ft CRIT.DEPH Hw= .00ft
CRIT.DEPH CONTROL Vh= .142ft
Dcr= .393ft CRIT.DEPH Hw= .00ft
CRIT.DEPH CONTROL Vh= .156ft
Dcr= .428ft CRIT.DEPH Hw= .00ft
FLOW PRECEDENCE SET TO
UPSTREAM CONTROLLING
STRUCTURE
FULL FLOW...Lfull= 160.88ft Vh= 9.47ft
HL= 4.677ft Hw= .00ft

Subsection: Individual Outlet Curves
Label: PP 2,3,4

Return Event: 1 Years
Storm Event: 1-Year

RATING TABLE FOR ONE OUTLET TYPE
Structure ID = Riser (Inlet Box)

Upstream ID = (Pond Water Surface)
Downstream ID = Culvert (Culvert-Circular)

Water Surface Elevation (ft)	Device Flow (ft ³ /s)	(Into) Headwater Hydraulic Grade Line (ft)	Converge Downstream Hydraulic Grade Line (ft)	Next Downstream Hydraulic Grade Line (ft)	Downstream Hydraulic Grade Line Error (ft)	Downstream Hydraulic Grade Line Error (ft)	Convergence Error (ft ² /s)	Downstream Channel Tailwater (ft)	Tailwater Error (ft)
348.60	0.00	0.00	0.00	0.00	0.00	0.00	0.00	(N/A)	0.00
349.10	0.00	0.00	0.00	0.00	0.00	0.00	0.00	(N/A)	0.00
349.60	0.00	0.00	0.00	0.00	0.00	0.00	0.00	(N/A)	0.00
349.93	0.00	0.00	0.00	0.00	0.00	0.00	0.00	(N/A)	0.00
350.10	0.00	0.00	0.00	350.06	0.00	0.00	0.00	(N/A)	0.00
350.60	0.00	0.00	0.00	350.32	0.00	0.00	0.00	(N/A)	0.00
351.10	0.00	0.00	0.00	350.42	0.00	0.00	0.00	(N/A)	0.00
351.60	0.00	0.00	0.00	350.49	0.00	0.00	0.00	(N/A)	0.00
352.10	0.00	0.00	0.00	350.59	0.00	0.00	0.00	(N/A)	0.00
352.60	0.00	0.00	0.00	350.59	0.00	0.00	0.00	(N/A)	0.00
353.10	13.79	353.10	353.10	353.10	0.00	0.00	0.00	(N/A)	0.00

Message:
WS below an invert; no flow.
WS below an invert; no flow.
WS below an invert; no flow.
WS below an invert; no flow.
WS below an invert; no flow.
WS below an invert; no flow.
WS below an invert; no flow.
WS below an invert; no flow.
WS below an invert; no flow.
WS below an invert; no flow.
FULLY CHARGED RISER: ADJUSTED TO WEIR: H = 0.31'

Subsection: Composite Rating Curve
Label: PP 2,3,4

Return Event: 1 Years
Storm Event: 1-Year

Composite Outflow Summary

Water Surface Elevation (ft)	Flow (ft ³ /s)	Tailwater Elevation (ft)	Convergence Error (ft)
348.60	0.00	(N/A)	0.00
349.10	0.00	(N/A)	0.00
349.60	0.00	(N/A)	0.00
349.93	0.00	(N/A)	0.00
350.10	0.06	(N/A)	0.00
350.60	0.50	(N/A)	0.00
351.10	0.78	(N/A)	0.00
351.60	0.99	(N/A)	0.00
352.10	1.18	(N/A)	0.00
352.60	1.34	(N/A)	0.00
353.10	9.58	(N/A)	0.00

Contributing Structures

(no Q): Riser,Orifice,Culvert
(no Q): Riser,Orifice,Culvert
(no Q): Riser,Orifice,Culvert
(no Q): Riser,Orifice,Culvert
Orifice,Culvert (no Q): Riser
Orifice,Culvert (no Q): Riser
Orifice,Culvert (no Q): Riser
Orifice,Culvert (no Q): Riser
Orifice,Culvert (no Q): Riser
Orifice,Culvert (no Q): Riser
Riser,Culvert (no Q): Orifice

Subsection: Elevation-Volume-Flow Table (Pond)
 Label: Blo 1

Return Event: 1 years
 Storm Event: 1-Year

Infiltration	
Infiltration Method (Computer)	No Infiltration
Initial Conditions	
Elevation (Water Surface, Initial)	349.00 ft
Volume (Initial)	0 ft ³
Flow (Initial Outlet)	0.00 ft ³ /s
Flow (Initial Infiltration)	0.00 ft ³ /s
Flow (Initial, Total)	0.00 ft ³ /s
Time Increment	0.050 hours

Elevation (ft)	Outflow (ft ³ /s)	Storage (ft ³)	Area (ft ²)	Infiltration (ft ³ /s)	Flow (Total) (ft ³ /s)	25 ft + 0 (ft ³ /s)
349.00	0.00	0	530	0.00	0.00	0.00
349.50	0.00	265	530	0.00	0.00	2.94
350.00	0.00	530	530	0.00	0.00	5.89
350.12	0.00	599	530	0.00	0.00	6.65
350.50	0.05	795	530	0.00	0.05	8.88
351.00	0.05	1,060	530	0.00	0.05	11.83
351.50	0.05	1,325	530	0.00	0.05	14.77
352.00	0.05	1,683	2,650	0.00	0.05	18.74
352.50	0.05	3,120	3,107	0.00	0.05	34.72
353.00	9.82	4,795	3,600	0.00	9.82	63.10

Subsection: Elevation-Volume-Flow Table (Pond)
 Label: Blo 2

Return Event: 1 years
 Storm Event: 1-Year

Infiltration	
Infiltration Method (Computer)	No Infiltration
Initial Conditions	
Elevation (Water Surface, Initial)	351.25 ft
Volume (Initial)	0 ft ³
Flow (Initial Outlet)	0.00 ft ³ /s
Flow (Initial Infiltration)	0.00 ft ³ /s
Flow (Initial, Total)	0.00 ft ³ /s
Time Increment	0.050 hours

Elevation (ft)	Outflow (ft ³ /s)	Storage (ft ³)	Area (ft ²)	Infiltration (ft ³ /s)	Flow (Total) (ft ³ /s)	25 ft + 0 (ft ³ /s)
351.25	0.00	0	132	0.00	0.00	0.00
351.75	0.00	66	132	0.00	0.00	0.73
352.19	0.00	124	132	0.00	0.00	1.38
352.25	0.01	132	132	0.00	0.01	1.48
352.75	0.05	198	132	0.00	0.05	2.25
353.25	0.05	264	132	0.00	0.05	2.98
353.75	0.05	330	132	0.00	0.05	3.72
354.25	0.05	419	660	0.00	0.05	4.71
354.75	0.05	801	875	0.00	0.05	8.95
355.25	10.25	1,799	1,120	0.00	10.25	24.68

Subsection: Elevation-Volume-Flow Table (Pond)
 Label: Bio 3

Return Event: 1 years
 Storm Event: 1-Year

Infiltration	
Infiltration Method (Computed)	No Infiltration
Initial Conditions	
Elevation (Water Surface, Initial)	352.00 ft
Volume (Initial)	0 ft ³
Flow (Initial Outlet)	0.00 ft ³ /s
Flow (Initial Infiltration)	0.00 ft ³ /s
Flow (Initial, Total)	0.00 ft ³ /s
Time Increment	0.050 hours

Elevation (ft)	Outflow (ft ³ /s)	Storage (ft ³)	Area (ft ²)	Infiltration (ft ³ /s)	Flow (Total) (ft ³ /s)	25'(t+O) (ft ³ /s)
352.00	0.00	0	146	0.00	0.00	0.00
352.50	0.05	73	146	0.00	0.05	0.86
353.00	0.05	146	146	0.00	0.05	1.67
353.50	0.05	219	146	0.00	0.05	2.48
354.00	0.05	292	146	0.00	0.05	3.29
354.50	0.05	365	146	0.00	0.05	4.11
355.00	0.05	438	730	0.00	0.05	5.20
355.50	0.05	973	1,238	0.00	0.05	10.86
356.00	7.04	1,852	2,130	0.00	7.04	27.40

Subsection: Elevation-Volume-Flow Table (Pond)
 Label: Bio 4

Return Event: 1 years
 Storm Event: 1-Year

Infiltration	
Infiltration Method (Computed)	No Infiltration
Initial Conditions	
Elevation (Water Surface, Initial)	351.00 ft
Volume (Initial)	0 ft ³
Flow (Initial Outlet)	0.00 ft ³ /s
Flow (Initial Infiltration)	0.00 ft ³ /s
Flow (Initial, Total)	0.00 ft ³ /s
Time Increment	0.050 hours

Elevation (ft)	Outflow (ft ³ /s)	Storage (ft ³)	Area (ft ²)	Infiltration (ft ³ /s)	Flow (Total) (ft ³ /s)	25'(t+O) (ft ³ /s)
351.00	0.00	0	150	0.00	0.00	0.00
351.50	0.05	75	150	0.00	0.05	0.88
352.00	0.05	150	150	0.00	0.05	1.72
352.50	0.05	225	150	0.00	0.05	2.55
353.00	0.05	300	150	0.00	0.05	3.38
353.50	0.05	375	150	0.00	0.05	4.22
354.00	0.05	476	740	0.00	0.05	5.34
354.50	0.05	1,005	1,412	0.00	0.05	11.21
355.00	6.98	1,924	2,300	0.00	6.98	28.36

Subsection: Elevation-Volume-Flow Table (Pond)
 Label: Bio 5

Return Event: 1 years
 Storm Event: 1-Year

Infiltration	
Infiltration Method (Computed)	No Infiltration
Initial Conditions	
Elevation (Water Surface, Initial)	350.33 ft
Volume (Initial)	0 ft ³
Flow (Initial Outlet)	0.00 ft ³ /s
Flow (Initial Infiltration)	0.00 ft ³ /s
Flow (Initial, Total)	0.00 ft ³ /s
Time Increment	0.050 hours

Elevation (ft)	Outflow (ft ³ /s)	Storage (ft ³)	Area (ft ²)	Infiltration (ft ³ /s)	Flow (Total) (ft ³ /s)	25 ft + 0 (ft ³ /s)
350.33	0.00	0	154	0.00	0.00	0.00
350.83	0.05	77	154	0.00	0.05	0.90
351.33	0.05	154	154	0.00	0.05	1.76
351.83	0.05	231	154	0.00	0.05	2.62
352.33	0.05	308	154	0.00	0.05	3.47
352.83	0.05	385	154	0.00	0.05	4.33
353.33	0.05	469	770	0.00	0.05	5.46
353.83	0.05	1,031	1,433	0.00	0.05	11.51
354.33	7.06	1,956	2,300	0.00	7.06	28.80

Subsection: Elevation-Volume-Flow Table (Pond)
 Label: Bio 6

Return Event: 1 years
 Storm Event: 1-Year

Infiltration	
Infiltration Method (Computed)	No Infiltration
Initial Conditions	
Elevation (Water Surface, Initial)	348.50 ft
Volume (Initial)	0 ft ³
Flow (Initial Outlet)	0.00 ft ³ /s
Flow (Initial Infiltration)	0.00 ft ³ /s
Flow (Initial, Total)	0.00 ft ³ /s
Time Increment	0.050 hours

Elevation (ft)	Outflow (ft ³ /s)	Storage (ft ³)	Area (ft ²)	Infiltration (ft ³ /s)	Flow (Total) (ft ³ /s)	25 ft + 0 (ft ³ /s)
348.50	0.00	0	203	0.00	0.00	0.00
349.00	0.05	102	203	0.00	0.05	1.18
349.50	0.05	203	203	0.00	0.05	2.30
350.00	0.05	305	203	0.00	0.05	3.43
350.50	0.05	406	203	0.00	0.05	4.56
351.00	0.05	508	203	0.00	0.05	5.69
351.50	0.05	644	1,016	0.00	0.05	7.21
352.00	0.05	1,275	1,524	0.00	0.05	14.22
352.50	10.84	2,185	2,134	0.00	10.84	35.12

Subsection: Elevation-Volume-Flow Table (Pond)
 Label: PP 1,S

Return Event: 1 years
 Storm Event: 1-Year

Infiltration	
Infiltration Method (Computed)	Average Infiltration Rate
Infiltration Rate (Average)	0.5000 in/h
Initial Conditions	
Elevation (Water Surface, Initial)	348.72 ft
Volume (Initial)	0 ft ³
Flow (Initial Outlet)	0.00 ft ² /s
Flow (Initial Infiltration)	0.00 ft ² /s
Flow (Initial, Total)	0.00 ft ² /s
Time Increment	0.050 hours

Elevation (ft)	Outflow (ft ² /s)	Storage (ft ³)	Area (ft ²)	Infiltration (ft ² /s)	Flow (Total) (ft ² /s)	2S/t + O (ft ² /s)
348.72	0.00	0	1,962	0.00	0.00	0.00
349.22	0.00	981	1,962	0.02	0.02	10.92
349.72	0.00	1,962	1,962	0.02	0.02	21.82
350.05	0.00	2,609	1,962	0.02	0.02	29.02
350.22	0.06	2,943	1,962	0.02	0.08	32.78
350.72	0.50	3,924	1,962	0.02	0.52	44.12
351.22	0.78	4,905	1,962	0.02	0.80	55.30
351.72	0.99	5,886	1,962	0.02	1.02	66.42
352.22	1.18	7,180	3,268	0.04	1.21	80.99
352.72	1.34	9,209	4,905	0.06	1.40	103.72
353.22	10.55	11,662	4,905	0.06	10.61	140.18

Subsection: Elevation-Volume-Flow Table (Pond)
 Label: PP 2,3,4

Return Event: 1 years
 Storm Event: 1-Year

Infiltration	
Infiltration Method (Computed)	Average Infiltration Rate
Infiltration Rate (Average)	0.5000 in/h
Initial Conditions	
Elevation (Water Surface, Initial)	348.60 ft
Volume (Initial)	0 ft ³
Flow (Initial Outlet)	0.00 ft ² /s
Flow (Initial Infiltration)	0.00 ft ² /s
Flow (Initial, Total)	0.00 ft ² /s
Time Increment	0.050 hours

Elevation (ft)	Outflow (ft ² /s)	Storage (ft ³)	Area (ft ²)	Infiltration (ft ² /s)	Flow (Total) (ft ² /s)	2S/t + O (ft ² /s)
348.60	0.00	0	4,147	0.00	0.00	0.00
349.10	0.00	2,074	4,147	0.05	0.05	23.09
349.60	0.00	4,147	4,147	0.05	0.05	46.13
349.93	0.00	5,516	4,147	0.05	0.05	61.33
350.10	0.06	6,221	4,147	0.05	0.10	69.22
350.60	0.50	8,294	4,147	0.05	0.55	92.70
351.10	0.78	10,368	4,147	0.05	0.83	116.02
351.60	0.99	12,441	4,147	0.05	1.04	139.28
352.10	1.18	15,175	6,907	0.08	1.26	169.97
352.60	1.34	19,465	10,368	0.12	1.46	217.74
353.10	9.58	24,649	10,368	0.12	9.70	283.58

Return Event: 1 years
Storm Event: 1-Year

Subsection: Elevation-Volume-Flow Table (Pond)
Label: Revised Pond

Infiltration	Infiltration Method (Computed)	No Infiltration
Initial Conditions		
Elevation (Water Surface, Initial)	341.00 ft	
Volume (Initial)	12,371 ft ³	
Flow (Initial Outlet)	0.00 ft ³ /s	
Flow (Initial Infiltration)	0.00 ft ³ /s	
Flow (Initial, Total)	0.00 ft ³ /s	
Time Increment	0.050 hours	

Elevation (ft)	Outflow (ft ³ /s)	Storage (ft ³)	Area (ft ²)	Infiltration (ft ³ /s)	Flow (Total) (ft ³ /s)	25ft+0 (ft ³ /s)
337.00	0.00	0	1,369	0.00	0.00	0.00
337.50	0.00	748	1,626	0.00	0.00	8.31
338.00	0.00	1,630	1,805	0.00	0.00	18.11
338.50	0.00	2,657	2,207	0.00	0.00	29.52
339.00	0.00	3,840	2,530	0.00	0.00	42.67
339.50	0.00	5,296	3,310	0.00	0.00	58.84
340.00	0.00	7,168	4,156	0.00	0.00	79.64
340.50	0.00	9,309	5,185	0.00	0.00	105.65
341.00	0.00	12,371	6,280	0.00	0.00	137.45
341.50	0.21	15,700	7,043	0.00	0.21	174.65
342.00	0.33	19,421	7,850	0.00	0.33	216.12
342.50	0.42	23,557	8,701	0.00	0.42	262.17
343.00	0.49	28,130	9,596	0.00	0.49	313.04
343.50	0.55	33,131	10,412	0.00	0.55	368.67
344.00	0.61	38,548	11,262	0.00	0.61	428.92
344.50	0.62	40,488	11,559	0.00	0.62	450.49
345.00	5.94	44,399	12,145	0.00	5.94	499.26
345.50	14.00	50,699	13,052	0.00	14.00	577.32
346.00	21.48	57,448	13,940	0.00	21.48	659.80
346.50	25.14	64,644	14,846	0.00	25.14	743.40
347.00	40.36	72,389	15,781	0.00	40.36	842.69
347.50	46.41	80,429	16,744	0.00	46.41	948.06

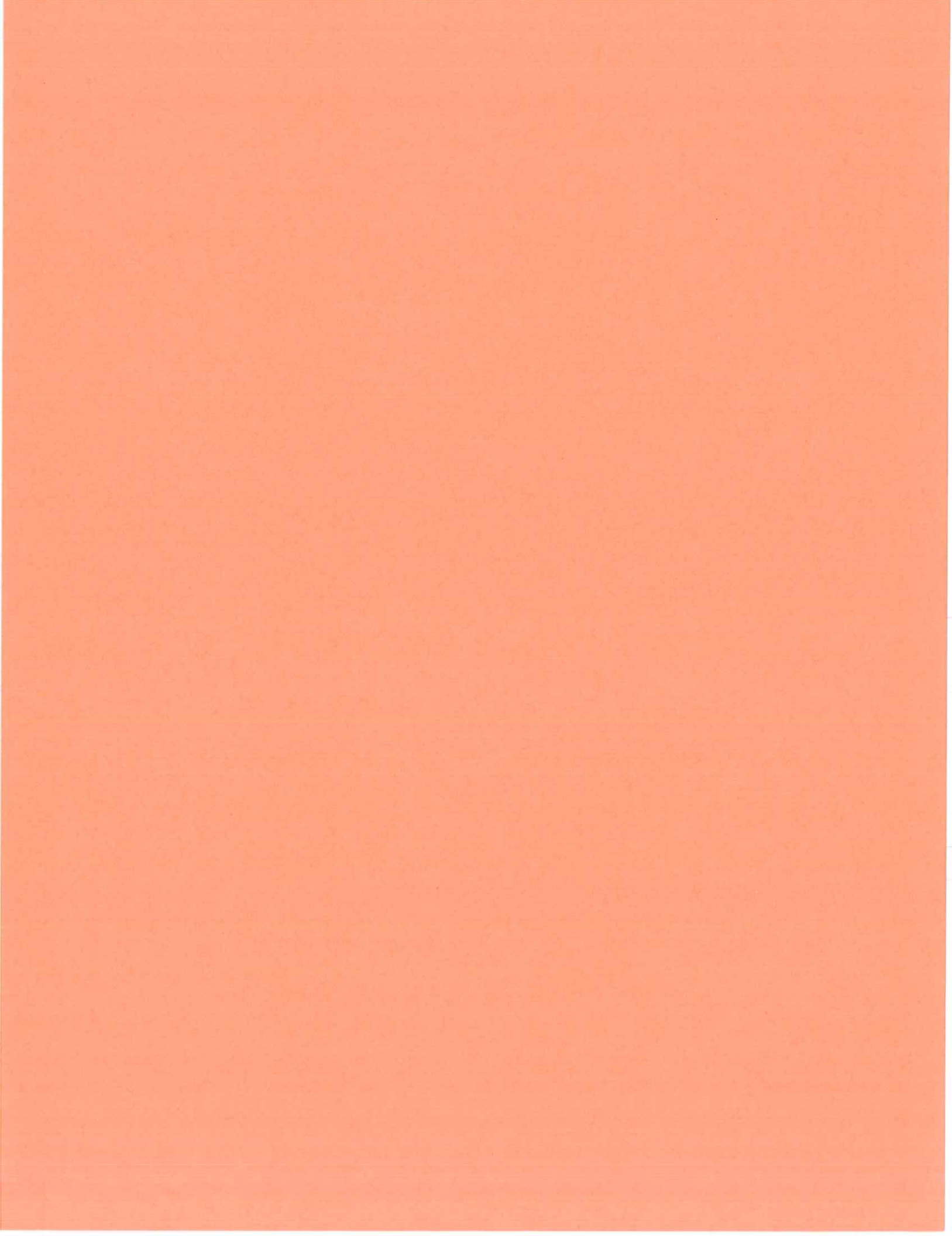

APPENDIX C

PRE/POST-DEVELOPMENT WATERSHED MAPS

L. 1988B P. 1982

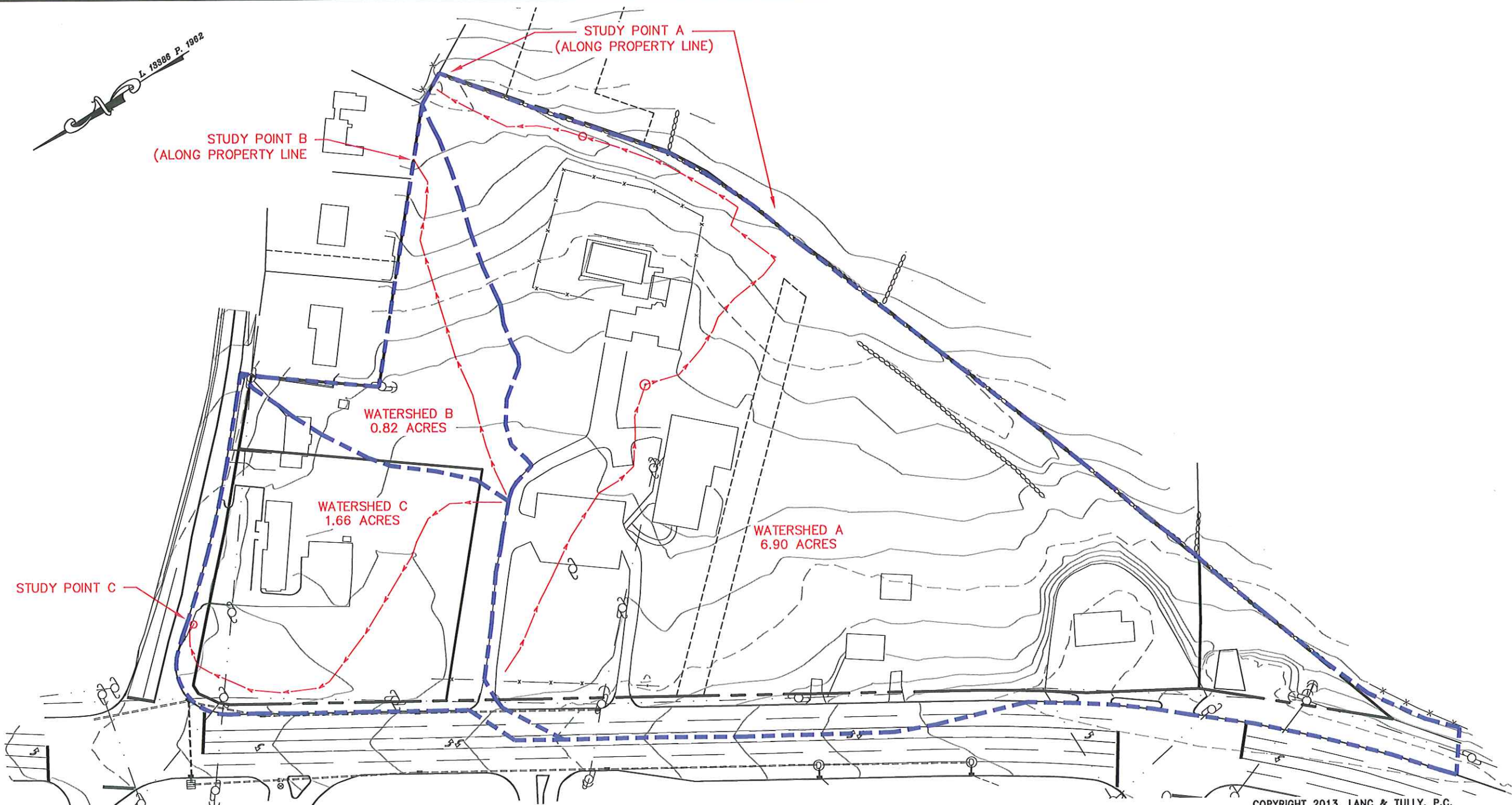

COPYRIGHT 2013, LANC & TULLY, P.C.

LEGEND:
 EXISTING PROPERTY LINE
 EXISTING MAJOR CONTOUR
 EXISTING MINOR CONTOUR
 WATERSHED BOUNDARY
 TIME OF CONCENTRATION FLOWPATH

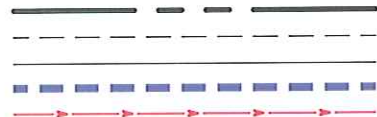

GRAPHIC SCALE



(IN FEET)
 1 inch = 100 ft.

LANC & TULLY ENGINEERING AND SURVEYING, P.C.		P.O. Box 687, Rt. 207 Goshen, N.Y. 10924 (845) 294-3700	
PRE-DEVELOPMENT DRAINAGE CONDITIONS			Date: DECEMBER 5, 2013
CRH REALTY VIII, LLC / BRITAIN PLAZA			Revisions: FEBRUARY 12, 2014
TOWN OF NEWBURGH ORANGE COUNTY, NEW YORK			CAD File: 120100-DRAINAGE-COMBINED
Drawn By: ESR			Layout: PRE-DEV
Checked By:		Scale: 1" = 100'	Sheet No.: 2 OF 4
Tax Map No.: 97-3-1,2,6,7,8,26 4-1-72.2 RW		Drawing No.: C3D D - 12 - 0100 - 02	

L. 13986 P. 1982

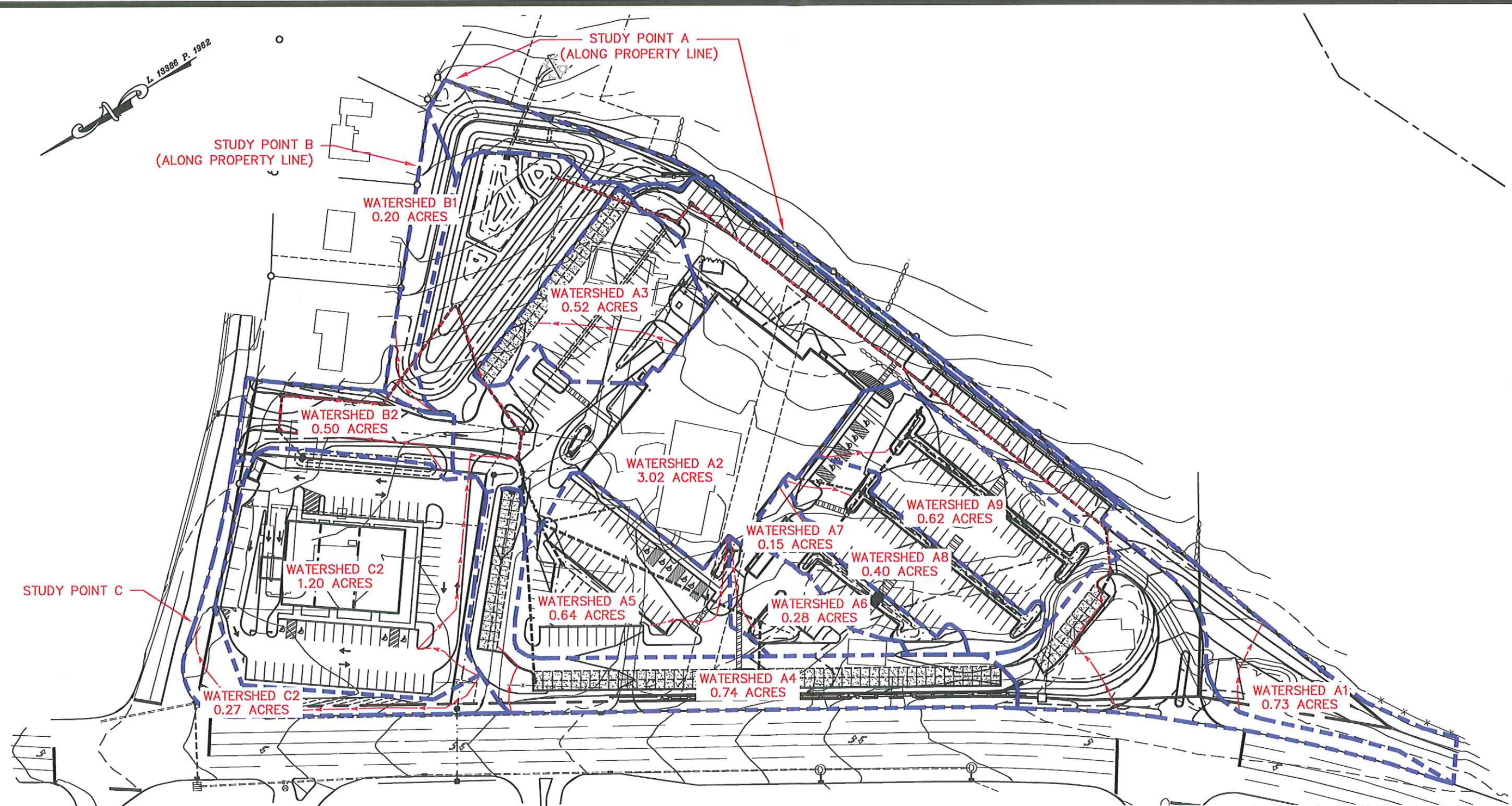

COPYRIGHT 2013, LANC & TULLY, P.C.

- LEGEND:**
- EXISTING PROPERTY LINE
 - EXISTING MAJOR CONTOUR
 - EXISTING MINOR CONTOUR
 - PROPOSED EDGE OF PAVEMENT
 - PROPOSED CONCRETE CURB
 - PROPOSED SIDEWALK
 - PROPOSED MAJOR CONTOUR
 - PROPOSED MINOR CONTOUR
 - PROPOSED DRAINAGE PIPE
 - WATERSHED BOUNDARY
 - TIME OF CONCENTRATION FLOWPATH

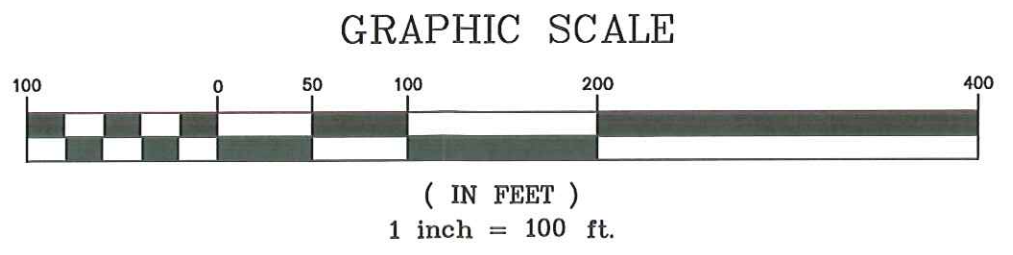
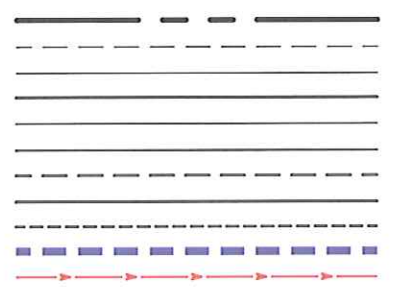

<p>LANC & TULLY ENGINEERING AND SURVEYING, P.C.</p>		<p>P.O. Box 687, Rt. 207 Goshen, N.Y. 10924 (845) 294-3700</p>	
<p>POST-DEVELOPMENT DRAINAGE CONDITIONS</p>			
<p>CRH REALTY VIII, LLC / BRITAIN PLAZA</p>		<p>TOWN OF NEWBURGH ORANGE COUNTY, NEW YORK</p>	
<p>Drawn By: ESR</p>	<p>Checked By:</p>	<p>Scale: 1" = 100'</p>	<p>Tax Map No.: 97-3-1,2,6,7,8,26 4-1-72.2 NW</p>
<p>Date: DECEMBER 5, 2013</p>		<p>Revisions: FEBRUARY 12, 2014</p>	
<p>Sheet No.: 3 OF 4</p>		<p>Drawing No.: C3D D - 12 - 0100 - 02</p>	

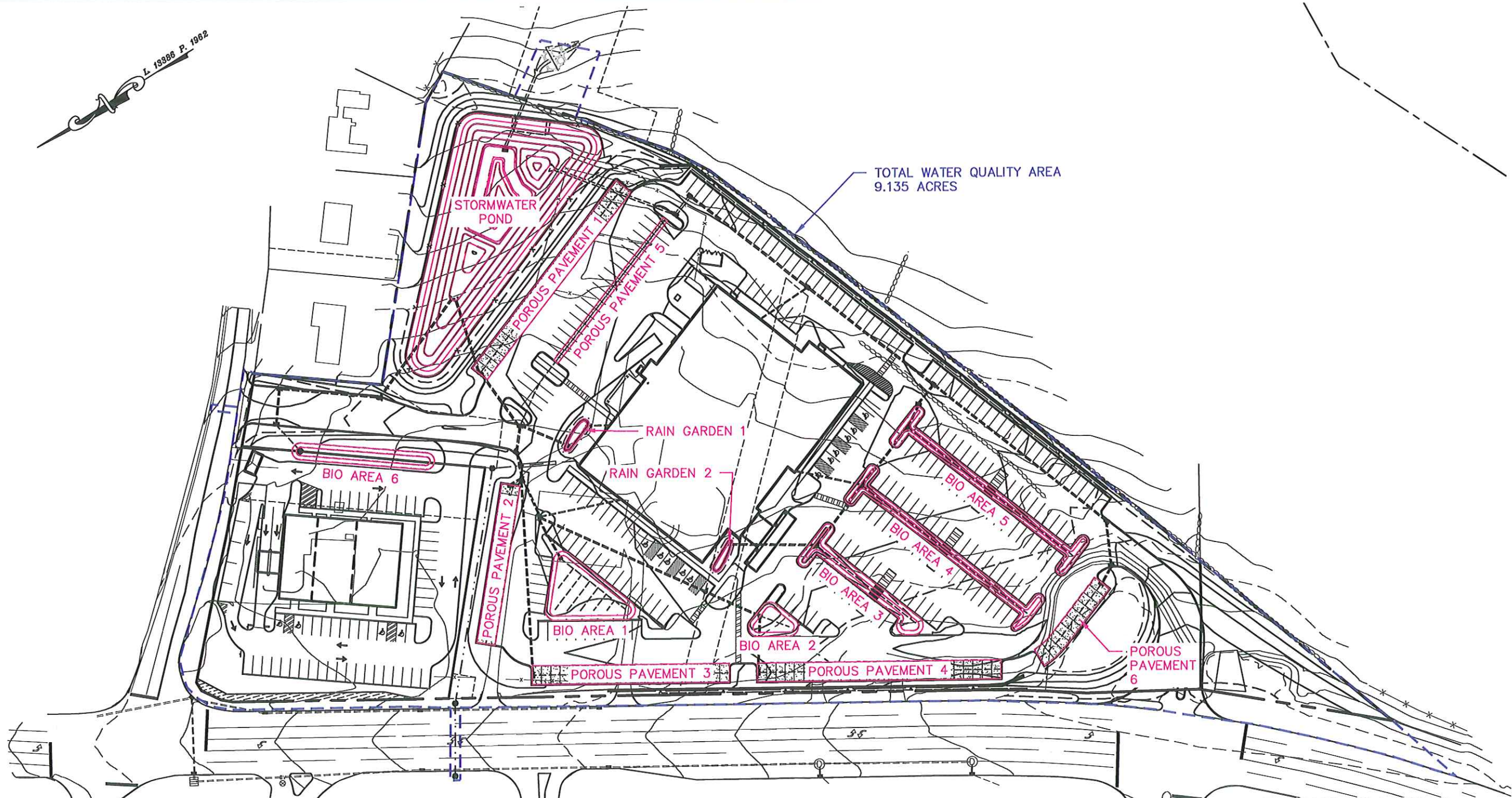
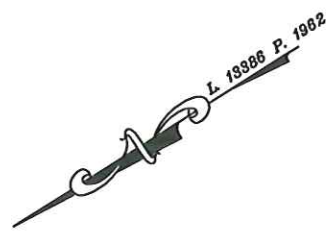

TOTAL WATER QUALITY AREA
9.135 ACRES

- LEGEND:
- EXISTING PROPERTY LINE
 - EXISTING MAJOR CONTOUR
 - EXISTING MINOR CONTOUR
 - PROPOSED EDGE OF PAVEMENT
 - PROPOSED CONCRETE CURB
 - PROPOSED SIDEWALK
 - PROPOSED MAJOR CONTOUR
 - PROPOSED MINOR CONTOUR
 - PROPOSED DRAINAGE PIPE
 - STORMWATER PRACTICE AREA
 - WATER QUALITY AREA

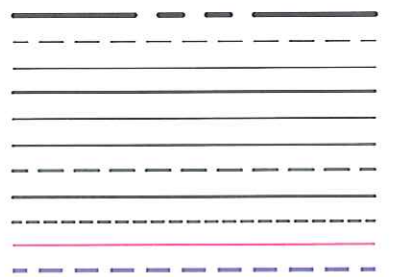

GRAPHIC SCALE



(IN FEET)
1 inch = 100 ft.

COPYRIGHT 2013, LANC & TULLY, P.C.

LANC & TULLY ENGINEERING AND SURVEYING, P.C.		P.O. Box 667, Rt. 207 Goshen, N.Y. 10924 (845) 294-3700	
STORMWATER PRACTICE AREA MAP			
CRH REALTY VIII, LLC / BRITAIN PLAZA TOWN OF NEWBURGH ORANGE COUNTY, NEW YORK		Date: DECEMBER 5, 2013 Revisions: FEBRUARY 12, 2014	
		CAD File: 120100-DRAINAGE-COMBINED Layout: PRACTICES Sheet No.: 4 OF 4	
Drawn By: ESR	Checked By:	Scale: 1" = 100'	Tax Map No.: 97-3-1,2,6,7,8,26 4-1-72.2 NW Drawing No.: C30 D - 12 - 0100 - 02

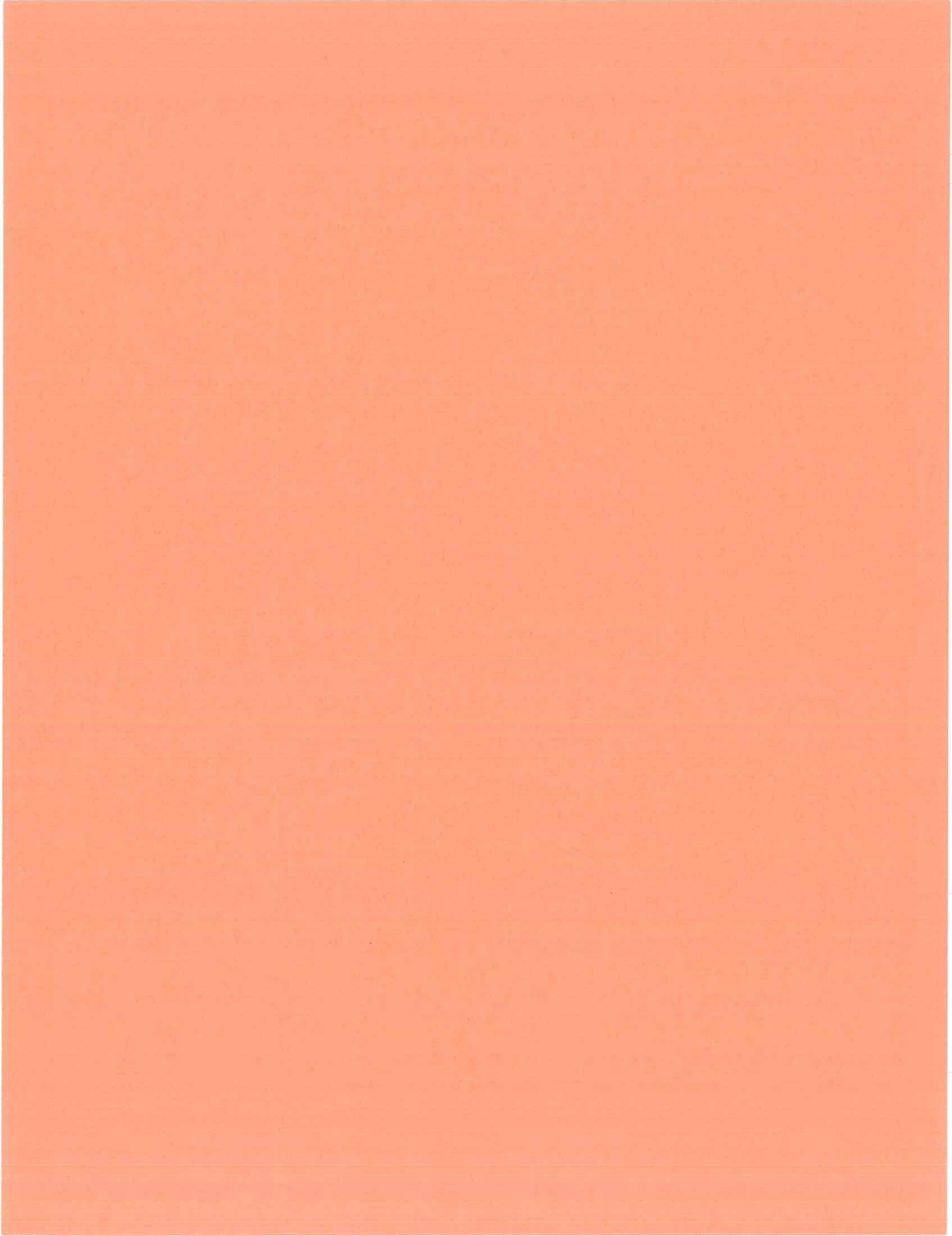

APPENDIX D

CALCULATIONS:

WATER QUALITY/RUNOFF REDUCTION VOLUME

CHANNEL PROTECTION VOLUME

STORMWATER PRACTICE DESIGN

**CRH REALTY VIII, LLC
Town of Newburgh, New York**

*Water Quality/Runoff Reduction Volume Summary
Total Site*

Required Water Quality Volume (WQv)

Drainage Area = 397,921 SF
 Impervious Area = 246,125 SF
Required WQv = 24,141 CF (from water quality calc sheet)
Required WQv + 10% = 26,555 CF (Required to treat additional 10% in watershed for Lake Washington)

NYSDEC requires that WQv be treated through use of Green Infrastructure Practices. These practices reduce the required WQv by reducing the drainage area or impervious area in the WQv calculation or by direct volume reduction of the required WQv. WQv treatment provided by the Green Infrastructure Practices is called Runoff Reduction Volume (RRv). The project must provide a minimum amount of WQv treatment in the Green Infrastructure Practices based on the Hydrologic Soil Group at the site.

Runoff Reduction/Water Quality Treatment Practices	RRv Deductions			WQv Treatment Volume (CF)
	Drainage Area (SF)	Impervious Area (SF)	Volume (CF)	
<p>Tree Planting/Tree Pit (Area Based Deduction) Notes: See landscaping plans for locations of trees.</p> <p align="center">Number of Roadside Proposed Trees = 35 Drainage Area Reduction (100 SF/Tree) = 3,500 SF</p>		3,500		
<p>Rain Garden (Volume Based Deduction) Notes: 2 rain gardens will be provide water quality treatment for small tributary areas including a portion of the proposed building entryway roof.</p> <p align="center">Stormwater Pond Water Quality Volume = 301 CF (from rain garden calc sheet)</p>				301
<p>Standard SMP - Stormwater Pond (Volume Based Deduction) Notes: Stormwater pond will provide quantity control for entire project and water quality treatment for remaining after bio-retention areas and porous pavement areas.</p> <p align="center">Stormwater Pond Water Quality Volume = 9,159 CF (from pond calc sheet)</p>				9,159
<p>Porous Pavement (Volume Based Deduction) Notes: 6 sections of porous pavement to capture a portion of parking area runoff.</p> <p align="center">Porous Pavement Treatment Capacity = 6,780 CF (from pavement calc sheet)</p>			6,780	
<p>Standard SMP - Bio-Retention Areas (Volume Based Deduction) Notes: 6 bio-retention areas located in parking lot island will treat a portion of parking lot runoff. In D soils areas require an underdrain and can provide 40% runoff reduction capacity.</p> <p align="center">Total Bio-Retention Area Treatment Capacity = 9,860 CF (from bio calc sheet) Maximum Deduction Allowed = 3,944 CF Deduction = 40% Remaining Treatment is standard WQv = 5,916 CF</p>			3,944	5,916

CRH REALTY VIII, LLC
Town of Newburgh, New York

Total	0	3,500	10,724	15,376
--------------	---	-------	--------	--------

Provided Runoff Reduction Volume Calculation

Drainage Area =	397,921	SF
Drainage Area Deduction =	0	SF
New Drainage Area =	397,921	SF
Impervious Area =	246,125	SF
Impervious Area Deduction =	3,500	SF
New Impervious Area =	242,625	SF
New Drainage Area =	397,921	
New Impervious Area =	242,625	
Rv =	0.60	
Reduced WQv =	24,819	CF
Volume Deduction =	10,724	CF
Reduced WQv =	14,095	CF

Provided RRv = Original WQv - Reduced WQv
Provided RRv = 12,460 CF

Required Water Quality Volume (WQv) =	26,555	CF
Provided Runoff Reduction Volume (RRv) =	12,460	CF
Provided Water Quality Volume (WQv) =	15,376	CF
Total Provided RRv and WQv =	27,836	CF

Minimum Required Runoff Reduction Volume Treatment

$$\text{Minimum RRv} = \frac{P * Rv * Ai}{12}$$

P = 1.2 inch
Rv = 0.05 + 0.009 * I (I=100%)

Ai (Impervious for Runoff Reduction) =	S * Aic
Aic (New Impervious Cover) =	246,125 SF
Specific Reduction Factor (HSG C) =	0.200
Ai =	49,225 SF

	Reduction Factor	Percent of Site	Weighted Reduction
HSG A	0.55	0.00%	0.000
B	0.40	0.00%	0.000
C	0.30	0.00%	0.000
D	0.20	100.00%	0.200

Minimum RRv =	4,676	CF
Provided RRv =	12,460	CF
Provided RRv is Greater than the Minimum.		

Lanc and Tully Engineering, P.C.

Project Name: CRH Realty VIII / Britain Plaza - Total Site
 Project Location: Town of Newburgh, NY

Water Quality Volume Calculation:

$$WQv = \frac{(P) * (Rv) * (A)}{12}$$

$$Rv = 0.05 + 0.009(I)$$

Impervious Acreage	=	5.650	Acres
Contributing Site Area	=	9.135	Acres
I (% Impervious)	=	61.9	%

Runoff Coefficient (Rv) = 0.61 * Use Minimum of 0.2 for regulated sites
 Sheet has been designed to maintain 0.2 min.

90% Rainfall Event	P	1.2	* Rainfall from NYSDEC SWM Figure 4.1
Site Area (Contributing)	A	9.135	

REQUIRED WATER QUALITY VOLUME	=	0.554	AC-FT
		24,141	CU-FT

WQv = Water Quality Volume (ac-ft)
 P = 90% Rainfall Event (in)
 Rv = Runoff Coefficient
 I = % impervious of the site
 A = Area of the site (Contributing Acreage)

Lanc and Tully Engineering, P.C.

Project Name: CRH Realty VIII - A2
 Project Location: Town of Newburgh, NY

Channel Protection Volume Calculation:

$$V_s = \frac{CP_v = (V_s N_r)(Q-1 \text{ Year})(A)}{12}$$

Site Curve Number (CN)	93
Precipitation (P) (in)	2.9
Time of Concentration (Hrs.)	0.1420
Q-1 Year Runoff (in.)	2.2
Site Area (acres)	3.020

CP_v = Channel Protection Volume (ac-ft)
 V_s = Required Storage Volume (ac-ft)
 V_r = Runoff Volume (ac-ft)
 Q-1 Year = Post Developed Runoff for 1 year Design Storm (in)
 A = Drainage Area
 CN = Site Curve Number
 P = Rainfall for Storm event (in)

la = Initial Abstraction
 la = 0.1505
 la/P = 0.0519
 Using Exhibit 4-III - Unit Peak Discharge (Qu) Type III Distribution

Qu = 650 csm/in

Using Figure D.11.2 - Detention Time vs. Discharge Ratios for 24 hours

Qo/Qi = 0.030

Vs/Nr = 0.641

CP_v = V_s = 0.3547 Ac-Ft

REQUIRED CHANNEL PROTECTION VOLUME	=	0.355	AC-FT
	=	15,449	CU-FT

Lanc and Tully Engineering, P.C.

Project Name: CRH Realty VIII - A3
 Project Location: Town of Newburgh, NY

Channel Protection Volume Calculation:

$$V_s = \frac{CPV = (VsNr)(Q-1Year)(A)}{12}$$

Site Curve Number (CN) 90
 Precipitation (P) (in) 2.9
 Time of Concentration (Hrs.) 0.0940
 Q-1 Year Runoff (in.) 1.9
 Site Area (acres) 0.521

CPV = Channel Protection Volume (ac-ft)
 Vs = Required Storage Volume (ac-ft)
 Vr = Runoff Volume (ac-ft)
 Q-1 Year = Post Developed Runoff for 1 year Design Storm (in)
 A = Drainage Area
 CN = Site Curve Number
 P = Rainfall for Storm event (in)

la = Initial Abstraction

la= 0.2222

la/P= 0.0766

Using Exhibit 4-III - Unit Peak Discharge (Qu) Type III Distribution

Qu= 700 csm/in

Using Figure D.11.2 - Detention Time vs. Discharge Ratios for 24 hours

Qo/Qi= 0.030

Vs/Nr= 0.641

CPV=Vs= 0.0528 Ac-Ft

REQUIRED CHANNEL PROTECTION VOLUME	=	0.053	AC-FT
	=	2,301	CU-FT

Lanc and Tully Engineering, P.C.

Project Name: CRH Realty VIII - A4
 Project Location: Town of Newburgh, NY

Channel Protection Volume Calculation:

$$V_s = \frac{CP_v \times (V_s/N_r)(Q-1\text{Year})(A)}{12}$$

Site Curve Number (CN)	86
Precipitation (P) (in)	2.9
Time of Concentration (Hrs.)	0.0950
Q-1 Year Runoff (in.)	1.6
Site Area (acres)	0.742

CP_v = Channel Protection Volume (ac-ft)
 V_s = Required Storage Volume (ac-ft)
 V_r = Runoff Volume (ac-ft)
 Q-1 Year = Post Developed Runoff for 1 year Design Storm (in)
 A = Drainage Area
 CN = Site Curve Number
 P = Rainfall for Storm event (in)

la = Initial Abstraction
 la = 0.3256
 la/P = 0.1123
 Using Exhibit 4-III - Unit Peak Discharge (Qu) Type III Distribution

Qu = 650 csm/in

Using Figure D.11.2 - Detention Time vs. Discharge Ratios for 24 hours

Qo/Qi = 0.030
 Vs/Nr = 0.641
 CPv=Vs = 0.0634 Ac-Ft

REQUIRED CHANNEL PROTECTION VOLUME	=	0.063	AC-FT
	=	2,760	CU-FT

Lanc and Tully Engineering, P.C.

Project Name: CRH Realty VIII - A5
 Project Location: Town of Newburgh, NY

Channel Protection Volume Calculation:

$$V_s = \frac{CPV = (Vs/Nr)(Q-1Year)(A)}{12}$$

Site Curve Number (CN)	92
Precipitation (P) (in)	2.9
Time of Concentration (Hrs.)	0.1890
Q-1 Year Runoff (in.)	2.1
Site Area (acres)	0.639

CPV = Channel Protection Volume (ac-ft)
 Vs = Required Storage Volume (ac-ft)
 Vr = Runoff Volume (ac-ft)
 Q-1 Year = Post Developed Runoff for 1 year Design Storm (in)
 A = Drainage Area
 CN = Site Curve Number
 P = Rainfall for Storm event (in)

la = Initial Abstraction

la= 0.1739

la/P= 0.0600

Using Exhibit 4-III - Unit Peak Discharge (Qu) Type III Distribution

Qu= 600 csm/in

Using Figure D.11.2 - Detention Time vs. Discharge Ratios for 24 hours

Qo/Qi= 0.031

Vs/Nr= 0.639

CPV=Vs= 0.0715 Ac-Ft

REQUIRED CHANNEL PROTECTION VOLUME	=	0.071	AC-FT
	=	3,113	CU-FT

Lanc and Tully Engineering, P.C.

Project Name: CRH Realty VIII - A6
 Project Location: Town of Newburgh, NY

Channel Protection Volume Calculation:

$$V_s = \frac{CP_v \times (V_s/V_r)(Q-1) \text{Year}(A)}{12}$$

Site Curve Number (CN)	93
Precipitation (P) (in)	2.9
Time of Concentration (Hrs.)	0.1610
Q-1 Year Runoff (in.)	2.2
Site Area (acres)	0.283

CPv = Channel Protection Volume (ac-ft)
 Vs = Required Storage Volume (ac-ft)
 Vr = Runoff Volume (ac-ft)
 Q-1 Year = Post Developed Runoff for 1 year Design Storm (in)
 A = Drainage Area
 CN = Site Curve Number
 P = Rainfall for Storm event (in)

la = Initial Abstraction
 la = 0.1505
 la/P = 0.0519
 Using Exhibit 4-III - Unit Peak Discharge (Qu) Type III Distribution

Qu = 610 csm/in

Using Figure D.11.2 - Detention Time vs. Discharge Ratios for 24 hours

Qo/Qi = 0.031

Vs/Vr = 0.639

CPv = Vs = 0.0331 Ac-Ft

REQUIRED CHANNEL PROTECTION VOLUME	=	0.033	AC-FT
	=	1,443	CU-FT

Lanc and Tully Engineering, P.C.

Project Name: CRH Realty VIII - A7
 Project Location: Town of Newburgh, NY

Channel Protection Volume Calculation:

$$V_s = \frac{CPV = (VsNr)(Q-1Year)(A)}{12}$$

Site Curve Number (CN)	85
Precipitation (P) (in)	2.9
Time of Concentration (Hrs.)	0.1180
Q-1 Year Runoff (in.)	1.5
Site Area (acres)	0.150

CPV = Channel Protection Volume (ac-ft)
 Vs = Required Storage Volume (ac-ft)
 Vr = Runoff Volume (ac-ft)
 Q-1 Year = Post Developed Runoff for 1 year Design Storm (in)
 A = Drainage Area
 CN = Site Curve Number
 P = Rainfall for Storm event (in)

la = Initial Abstraction
 la = 0.3529
 la/P = 0.1217
 Using Exhibit 4-III - Unit Peak Discharge (Qu) Type III Distribution

Qu = 630 csm/in

Using Figure D.11.2 - Detention Time vs. Discharge Ratios for 24 hours

Qo/Qi =	0.030
Vs/Nr =	0.641
CPV = Vs =	0.0120 Ac-Ft

REQUIRED CHANNEL PROTECTION VOLUME	=	0.012	AC-FT
	=	524	CU-FT

Lanc and Tully Engineering, P.C.

Project Name: CRH Realty VIII - A8
 Project Location: Town of Newburgh, NY

Channel Protection Volume Calculation:

$$V_s = \frac{CP_v \times (V_s \times V_r)(Q-1 \text{ Year})(A)}{12}$$

Site Curve Number (CN) 93
 Precipitation (P) (in) 2.9
 Time of Concentration (Hrs.) 0.1170
 Q-1 Year Runoff (in.) 2.2
 Site Area (acres) 0.404

CPv = Channel Protection Volume (ac-ft)
 Vs = Required Storage Volume (ac-ft)
 Vr = Runoff Volume (ac-ft)
 Q-1 Year = Post Developed Runoff for 1 year Design Storm (in)
 A = Drainage Area
 CN = Site Curve Number
 P = Rainfall for Storm event (in)

la = Initial Abstraction

la= 0.1505

la/P= 0.0519

Using Exhibit 4-III - Unit Peak Discharge (Qu) Type III Distribution

Qu= 650 csm/in

Using Figure D.11.2 - Detention Time vs. Discharge Ratios for 24 hours

Qo/Qi= 0.030

Vs/Vr= 0.641

CPv=Vs= 0.0474 Ac-Ft

REQUIRED CHANNEL PROTECTION VOLUME			
	=	0.047	AC-FT
	=	2,066	CU-FT

Lanc and Tully Engineering, P.C.

Project Name: CRH Realty VIII - A9
 Project Location: Town of Newburgh, NY

Channel Protection Volume Calculation:

$$V_s = \frac{CP_v = (V_s/N_r)(Q-1\text{Year})(A)}{12}$$

Site Curve Number (CN)	95
Precipitation (P) (in)	2.9
Time of Concentration (Hrs.)	0.0830
Q-1 Year Runoff (in.)	2.4
Site Area (acres)	0.620

CP_v = Channel Protection Volume (ac-ft)
 V_s = Required Storage Volume (ac-ft)
 V_r = Runoff Volume (ac-ft)
 Q-1 Year = Post Developed Runoff for 1 year Design Storm (in)
 A = Drainage Area
 CN = Site Curve Number
 P = Rainfall for Storm event (in)

la = Initial Abstraction
 la = 0.1053
 la/P = 0.0363
 Using Exhibit 4-III - Unit Peak Discharge (Qu) Type III Distribution

Qu = 700 csm/in

Using Figure D.11.2 - Detention Time vs. Discharge Ratios for 24 hours

Qo/Qi = 0.030

Vs/Nr = 0.641

CPv=Vs = 0.0794 Ac-Ft

REQUIRED CHANNEL PROTECTION VOLUME	=	0.079	AC-FT
	=	3,457	CU-FT

Lanc and Tully Engineering, P.C.

Project Name: CRH Realty VIII / Britain Plaza - B2
 Project Location: Town of Newburgh, NY

Water Quality Volume Calculation:

$$WQv = \frac{(P) * (Rv) * (A)}{12}$$

$$Rv = 0.05 + 0.009(I)$$

Impervious Acreage	=	0.188	Acres
Contributing Site Area	=	0.293	Acres
I (% Impervious)	=	64.1	%

$$\text{Runoff Coefficient (Rv)} = 0.63$$

* Use Minimum of 0.2 for regulated sites
 Sheet has been designed to maintain 0.2 min.

90% Rainfall Event
 Site Area (Contributing)

P
 A

1.2 *Rainfall from NYSDEC SWM Figure 4.1
 0.293

REQUIRED WATER QUALITY VOLUME	=	0.018	AC-FT
		801	CU-FT

Lanc and Tully Engineering, P.C.

Project Name: CRH Realty VIII / Britain Plaza - B2
 Project Location: Town of Newburgh, NY

Channel Protection Volume Calculation:

$$V_s = \frac{CPV = (V_s N_r)(Q-1 \text{ Year})(A)}{12}$$

Site Curve Number (CN) 92
 Precipitation (P) (in) 2.9
 Time of Concentration (Hrs.) 0.1050
 Q-1 Year Runoff (in.) 2.1
 Site Area (acres) 0.293

CPV = Channel Protection Volume (ac-ft)
 V_s = Required Storage Volume (ac-ft)
 V_r = Runoff Volume (ac-ft)
 Q-1 Year = Post Developed Runoff for 1 year Design Storm (in)
 A = Drainage Area
 CN = Site Curve Number
 P = Rainfall for Storm event (in)

la = Initial Abstraction
 la = 0.1739
 la/P = 0.0600

Using Exhibit 4-III - Unit Peak Discharge (Qu) Type III Distribution

Qu = 650 csm/in

Using Figure D.11.2 - Detention Time vs. Discharge Ratios for 24 hours

Qo/Qi = 0.032

Vs/Nr = 0.638

CPV = Vs = 0.0327 Ac-Ft

REQUIRED CHANNEL PROTECTION VOLUME	=	0.033	AC-FT
	=	1,426	CU-FT

Lanc and Tully Engineering, P.C.

Project Name: CRH Realty VIII / Britain Plaza - C2
 Project Location: Town of Newburgh, NY

Water Quality Volume Calculation:

$$\frac{WQv = (P) * (Rv) * (A)}{12}$$

WQv = Water Quality Volume (ac-ft)

P = 90% Rainfall Event (in)

Rv = Runoff Coefficient

I = % impervious of the site

A = Area of the site (Contributing Acreage)

$$Rv = 0.05 + 0.009(I)$$

Impervious Acreage	=	0.899	Acres
Contributing Site Area	=	1.204	Acres
I (% Impervious)	=	74.7	%

$$\text{Runoff Coefficient (Rv)} = 0.72$$

* Use Minimum of 0.2 for regulated sites
 Sheet has been designed to maintain 0.2 min.

90% Rainfall Event
 Site Area (Contributing)

P
 A

1.2
 1.204

*Rainfall from NYSDEC SWM Figure 4.1

REQUIRED WATER QUALITY VOLUME	=	0.087	AC-FT
		3,785	CU-FT

Lanc and Tully Engineering, P.C.

Project Name: CRH Realty VIII / Britain Plaza - C2
 Project Location: Town of Newburgh, NY

Channel Protection Volume Calculation:

$$V_s = \frac{CP_v = (V_s N_r)(Q-1 \text{ Year})(A)}{12}$$

Site Curve Number (CN)	93
Precipitation (P) (in)	2.9
Time of Concentration (Hrs.)	0.1100
Q-1 Year Runoff (in.)	2.2
Site Area (acres)	1.204

CP_v = Channel Protection Volume (ac-ft)
 V_s = Required Storage Volume (ac-ft)
 V_r = Runoff Volume (ac-ft)
 Q-1 Year = Post Developed Runoff for 1 year Design Storm (in)
 A = Drainage Area
 CN = Site Curve Number
 P = Rainfall for Storm event (in)

la = Initial Abstraction
 la = 0.1505
 la/P = 0.0519
 Using Exhibit 4-III - Unit Peak Discharge (Qu) Type III Distribution

Qu = 650 csm/in

Using Figure D.11.2 - Detention Time vs. Discharge Ratios for 24 hours

Qo/Qi = 0.032

Vs/Nr = 0.638

CP_v = V_s = 0.1408 Ac-Ft

REQUIRED CHANNEL PROTECTION VOLUME	=	0.141	AC-FT
	=	6,131	CU-FT

CRH REALTY VIII, LLC / BRITAIN PLAZA
Town of Newburgh, New York

Channel Protection Volume Orifice Sizing

Total CPv = Channel Protection Volume

Qo = Average Outflow discharge, CPv/24 hr*60 min* 60 sec

h = head at orifice centerline, ft

C = Orifice Coefficient = 0.6

g = 32.2, ft/s

A = Qo/C*sqrt(2*g*h)

Area	Practice	Total CPv (CF)	Qo (CFS)	1-Year Peak Water Surface El.	Orifice Invert	Calculated Orifice Diameter (in)	Average Flowrate (CFS)	Chosen Orifice Diameter (in)
A2	Stormwater Pond	15,449	0.448	345.16	342.00	3.7	0.441	3.7
A3		2,301						
A4		2,760						
A5		3,113						
A6		1,443						
A7		524						
A8		2,066						
A9		3,457						
B2		1,426						
C2		6,131						
Total								

CRH REALTY VIII, LLC / BRITAIN PLAZA

Town of Newburgh, New York

Bio-Retention Area

Water Quality Volume and Design

Bio-Retention Area Characteristics

$$Af = (WQv \times df) / (k (hf + df) tf)$$

Af = surface area of filter bed, sf

df = filter bed depth, ft

k = media permeability, ft/day

hf = average water height, ft

tf = bed drain time, days

3

0.5

0.25

2

Area	Filter Bed Area (SF)	Underdrain Inv. El.	Bed El.	Berm El.	Riser El.	Provided Water Quality Volume (CF)	Provided Pre-Treatment (CF)	Total Provided Treatment (CF)
Area 1*	2,500	350.13	352.80	353.70	353.30	2,750	743	2,750
Area 2*	600	352.52	355.19	356.16	355.69	660	400	1,060
Area 3*	700	353.27	355.94	356.99	356.44	770	500	1,270
Area 4*	700	352.27	354.94	356.28	355.44	770	653	1,423
Area 5*	700	351.60	354.27	355.68	354.77	770	1,118	1,888
Area 6*	1,000	348.50	351.50	352.50	352.00	1,100	370	1,470
Total	6,200					6,820	3,783	9,860

* Elevation varies along length of bio-retention area, the listed elevations are for lowest point.

Bio-Retention Area Underdrain System Length

$$L = 10\% Af/W$$

Area I.D.	Filter Bed Area (SF)	10% of Filter Area (SF)	Width (FT)	Required Underdrain Length (FT)	Provided Underdrain Length (FT)
Area 1*	2,500	250	3.0	83	233
Area 2*	600	60	3.0	20	28
Area 3*	700	70	3.0	23	118
Area 4*	700	70	3.0	23	198
Area 5*	700	70	3.0	23	199
Area 6*	1,000	100	3.0	33	118

Gravel Diaphragm Water Quality Volume (Pre-Treatment)

Swale I.D.	Length (FT)	Width (FT)	Depth (FT)	Gravel Porosity	Required Water Quality Volume (25%) (CF)	Provided Water Quality Volume (CF)
Area 1*	297	2.5	2.5	0.4	688	743
Area 2*	160	2.5	2.5	0.4	265	400
Area 3*	200	2.5	2.5	0.4	318	500
Area 4*	261	2.5	2.5	0.4	356	653
Area 5*	447	2.5	2.5	0.4	472	1,118
Area 6*	148	2.5	2.5	0.4	368	370

**CRH REALTY VIII, LLC / BRITAIN PLAZA
Town of Newburgh, New York**

Rain Garden Design

$$V = A_{sm} * D_{sm} * n_{dl} + A_{dl} + D_{dl} + n_{dl} + A_{sm} * D_p$$

Vdl= volume of drainage layer (CF)
 Adl= area of drainage layer (SF)
 Ddl= depth of drainage layer (FT) 0.5
 ndl= drainage layer porosity 0.4
 Dp= ponding depth (ft) 0.5

Vsm= volume of soil media (CF)
 Asm= area of soil media (SF)
 Dsm= depth of soil media (FT) 2
 nsm= soil media porosity 0.2

Area	Total Area (SF)	Impervious Area (SF)	WQ Storm (in.)	Required Volume (CF)	Rain Garden Area (SF)	Vsm (CF)	Vdl (CF)	Volume of Ponding (CF)	Provided Volume (CF)
1	1,048	0	1.25	5	170	68	34	85	187
2	1,313	1,313	1.25	130	104	42	21	52	114
Total									301

CRH REALTY VIII, LLC / BRITAIN PLAZA
Town of Newburgh, New York

Porous Pavement Water Quality Volume and Design

n = stone porosity 0.4

Area	Filter Bed Area (SF)	Stone Layer Depth (ft)	Total Stone Volume (CF)	Depth of Stone Below Outlet Pipe (ft)	Stone Volume Below Outlet (CF)	Provided Water Quality Volume (CF)
Area 1	4,050	2	3,240	1.00	1,620	1,620
Area 2	2,754	2	2,203	1.00	1,102	1,102
Area 3	3,402	2	2,722	1.00	1,361	1,361
Area 4	4,212	2	3,370	1.00	1,685	1,685
Area 5	855	2	684	1.00	342	342
Area 6	1,677	2	1,342	1.00	671	671
Total	16,950					6,780

CRH REALTY VIII, LLC / BRITAIN PLAZA

Town of Newburgh, New York

Stormwater Detention Pond (P-2)

	Required	Provided	Required Storage (CF)	Provided Storage (CF)	Elevation Provided
Water Quality Volume	100%	107%	8,522	9,159	-
Forebay (Permanent Pool)	10%	55%	852	4,716	384.00
Permanent Pool	100%	117%	3,806	4,443	384.00

Outlet Structure	Dimensions (ft)	Inv. Elevation
Orifice - Round (diameter)	3.7"	341.00
Orifice - Square (dimensions)	45" x 12"	344.18
Grate	48" x 48"	346.00
Culvert (diameter)	24"	337.00
Emergency spillway	30'	346.25
Perimeter Berm		347.00

LANC & TULLY, P.C.

P.O. Box 687
GOSHEN, NY 10924
Tel (845) 294-3700
Fax (845) 294-8609
www.lanctully.com

JOB Crystal Run - Newburgh

SHEET NO. _____

OF _____

CALCULATED BY ESR

DATE 12/9/13

CHECKED BY _____

DATE REV, 2/7/14

SCALE _____

Rip rap Outlet Protection

Pond outlet

$$Q_{25} = 20.59 \text{ CFS}$$

$$d = 24''$$

$$\text{Flow depth} = 22''$$

$$V = 6.96 \text{ FPS}$$

$$TW < .5 D_0$$

$$Q_{\text{adjusted}} = \frac{\pi \cdot 1.83^2}{4} \times 6.96 = 18.37 \text{ CFS}$$

$$L_a = 13'$$

$$w = 2' + 13'$$

$$d_{50} = 5''$$

$$w = 15'$$

Inlet - A2 + A7 + A8 + A9

$$Q_{25} = 20.74 \text{ CFS}$$

$$d = 24''$$

$$\text{Flow depth} = 11''$$

$$V = 15.71 \text{ FPS}$$

$$TW > .5 D_0$$

$$Q_{\text{adjusted}} = \frac{\pi \cdot .87^2}{4} \times 15.71 = 9.34 \text{ CFS}$$

$$L_a = 32'$$

$$w = 2' + .4 \cdot 16'$$

$$d_{50} = 6''$$

$$w = 15'$$

Inlet - A3 + A4 + A5 + A6 + B2 + C2

$$Q_{25} = 5.47 \text{ CFS}$$

$$d = 15''$$

$$\text{Flow depth} = 6''$$

$$V = 12.53 \text{ FPS}$$

$$TW > .5 D_0$$

$$Q_{\text{adjusted}} = \frac{\pi \cdot .48^2}{4} \times 12.53 = 2.27 \text{ CFS}$$

- combine with riprap for B2+C2 outlet -

Inlet - B2 + C2

$$Q_{25} = 7.68 \text{ CFS}$$

$$d = 18''$$

$$\text{Flow depth} = 14''$$

$$V = 5.81 \text{ FPS}$$

$$TW > .5 D_0$$

$$Q_{\text{adjusted}} = \frac{\pi \cdot 1.17^2}{4} \times 5.81 = 6.24 \text{ CFS}$$

$$L_a = 8'$$

$$w = 1.5 + .4 \times 8'$$

$$d_{50} = 5''$$

$$w = 4.8'$$

Figure 5B.12
Outlet Protection Design—Minimum Tailwater Condition
(Design of Outlet Protection from a Round Pipe Flowing Full,
Minimum Tailwater Condition: $T_w < 0.5D_o$) (USDA - NRCS)

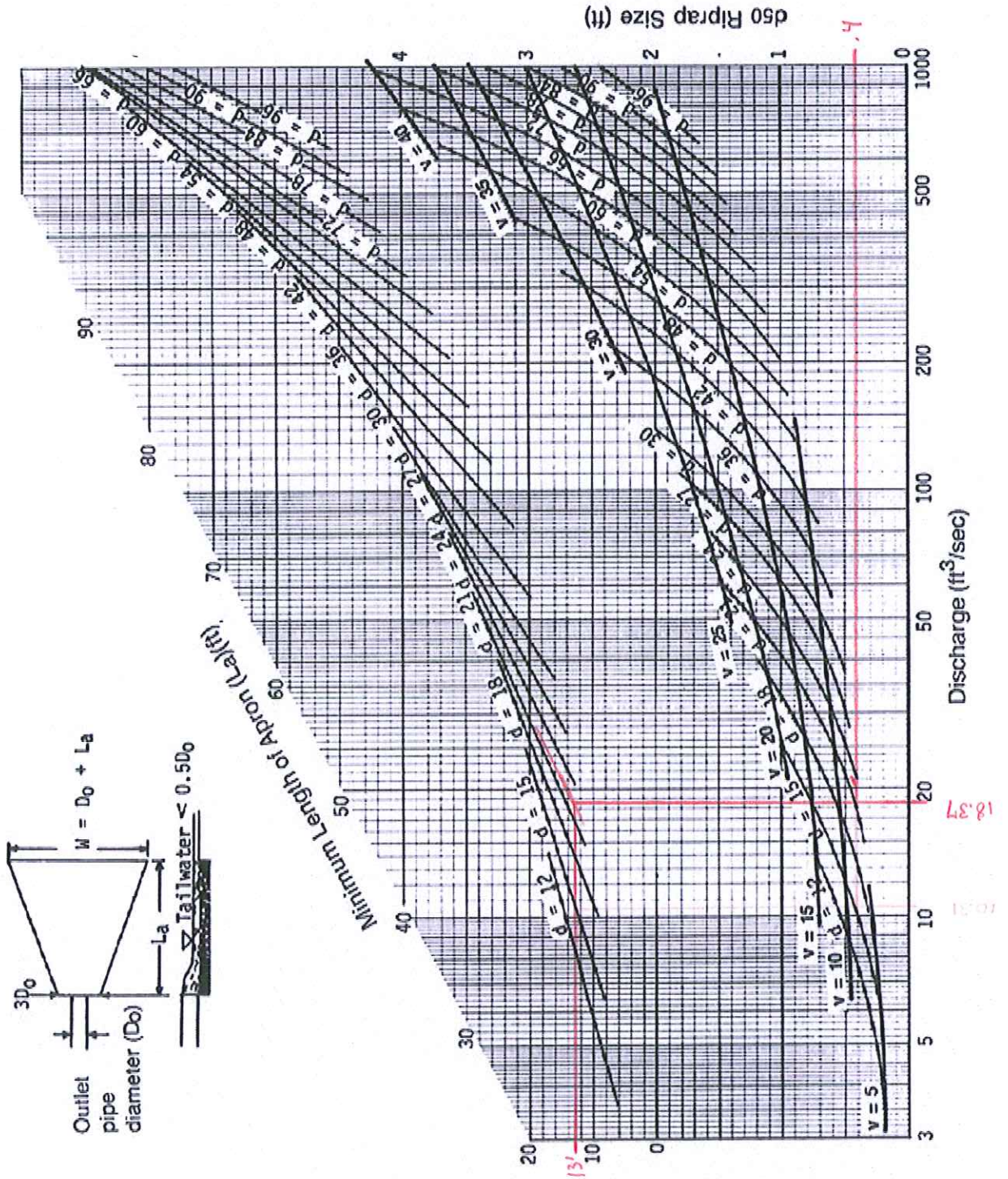
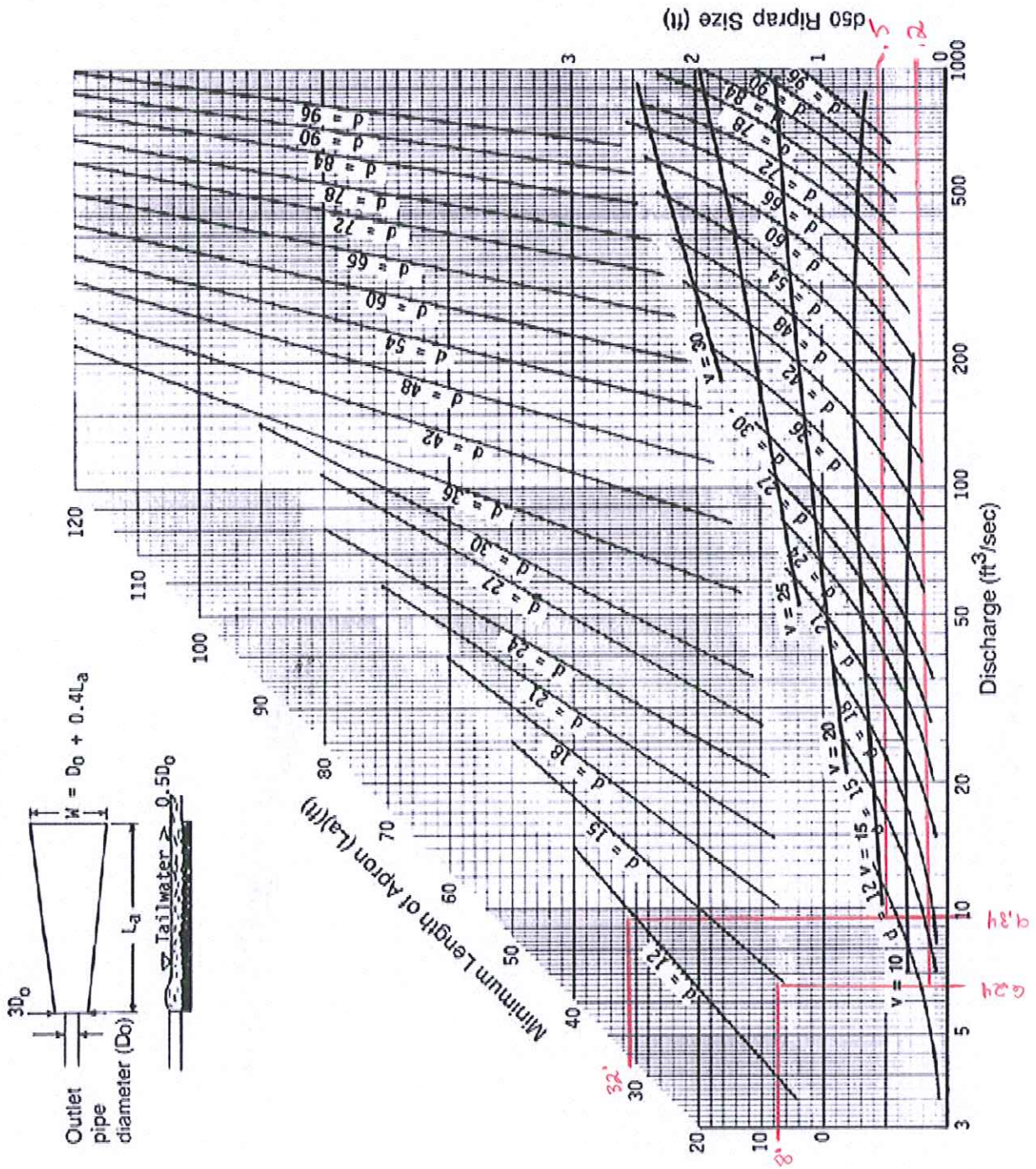

Figure 5B.13
Outlet Protection Design—Maximum Tailwater Condition
(Design of Outlet Protection from a Round Pipe Flowing Full,
Maximum Tailwater Condition: $T_w \geq 0.5D_o$) (USDA - NRCS)



LANC & TULLY, P.C.

P.O. Box 687
GOSHEN, NY 10924
Tel (845) 294-3700
Fax (845) 294-8609
www.lanctully.com

JOB Crystal Run - Newburgh

SHEET NO. _____ OF _____

CALCULATED BY ESR DATE 12/6/13

CHECKED BY _____ DATE rev. 2-7-14

SCALE _____

Level Spreader

$Q_{as} = 20.59 \text{ cfs}$

Entrance Width = 24'

Depth = 0.7'

Length = 30'

Transition = 20'

LANC & TULLY, P.C.

P.O. Box 687
GOSHEN, NY 10924
Tel (845) 294-3700
Fax (845) 294-8609
www.lanctully.com

JOB Crystal Run - Newburgh

SHEET NO. _____ OF _____

CALCULATED BY ESR DATE 12/10/13

CHECKED BY _____ DATE _____

SCALE _____

Anti-Seep Collars

$$L_s = y(z+4) \left[1 + \frac{\text{pipe slope}}{0.25 - \text{pipe slope}} \right]$$

$$L_s = 8.89(3+4) \left[1 + \frac{.005}{.25 - .005} \right]$$

$$L_s = 63.5 \text{ ft}$$

$$y = 346.89 - 338 = 8.89'$$

$$z = 3$$

$$\text{pipe slope} = .5\%$$

From Figure SA.31(2)

three collars → 5.25' collar

Figure 5A.31(2)
Anti-Seep Collar Design Charts (USDA - NRCS)

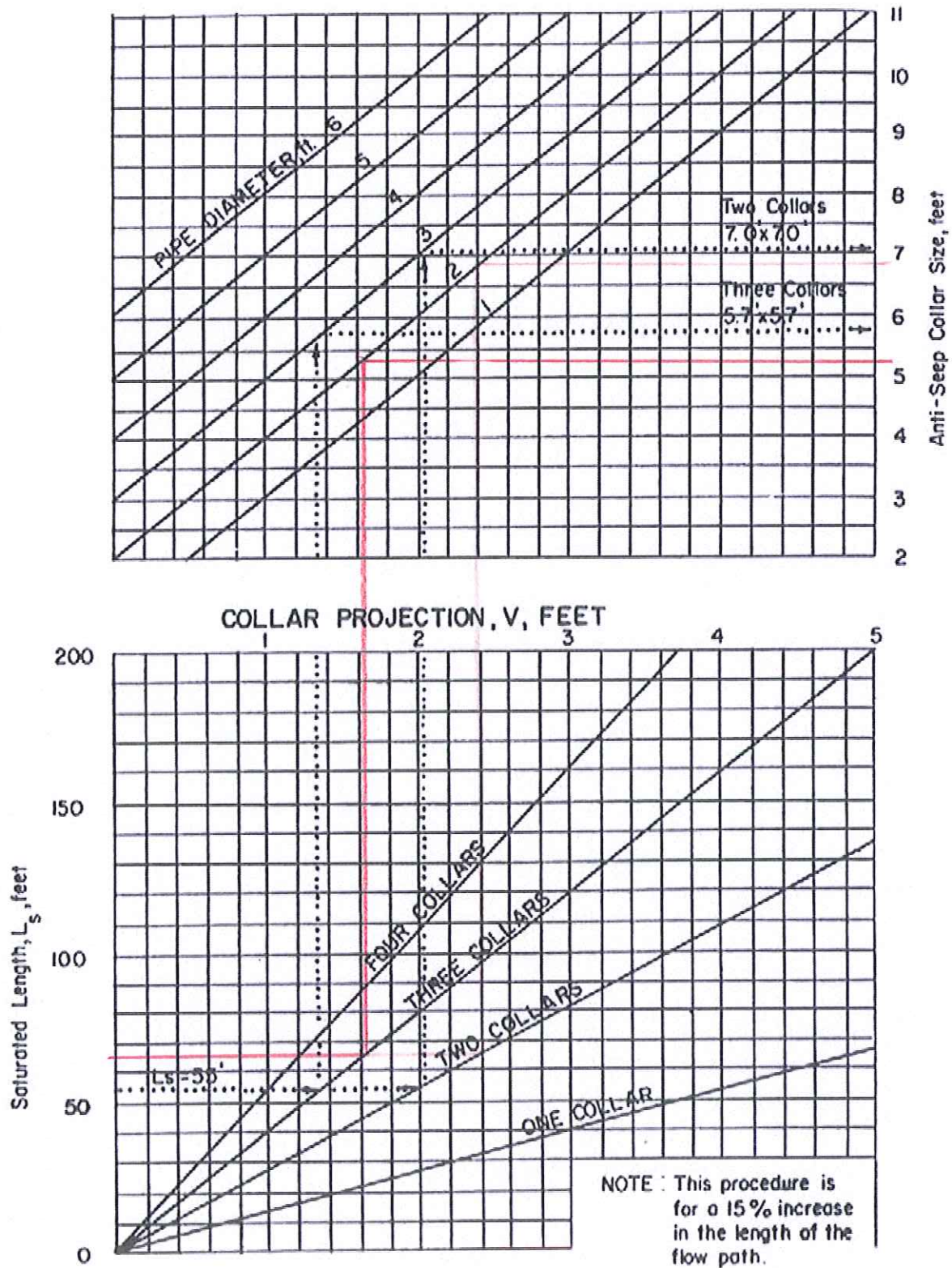

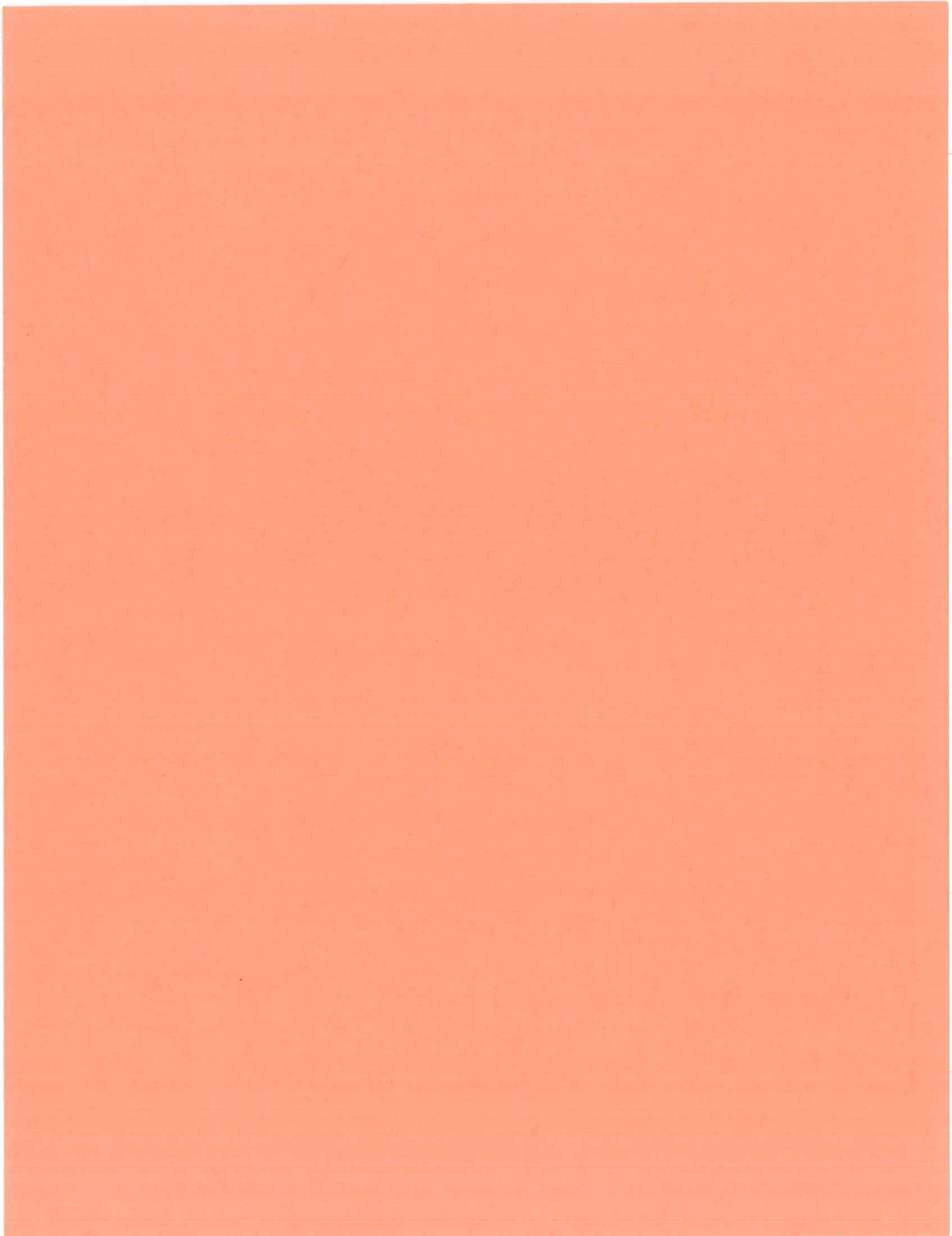

APPENDIX E

EXCERPTS FROM THE “NY STATE STORMWATER DESIGN MANUAL”
CONSTRUCTION SPECIFICATIONS

STANDARD AND SPECIFICATIONS FOR TEMPORARY SWALE



Definition

A temporary excavated drainage way.

Purpose

The purpose of a temporary swale is to prevent runoff from entering disturbed areas by intercepting and diverting it to a stabilized outlet or to intercept sediment laden water and divert it to a sediment trapping device.

Conditions Where Practice Applies

Temporary swales are constructed:

1. to divert flows from entering a disturbed area.
2. intermittently across disturbed areas to shorten overland flow distances.
3. to direct sediment laden water along the base of slopes to a trapping device.
4. to transport offsite flows across disturbed areas such as rights-of-way.

Swales collecting runoff from disturbed areas shall remain in place until the disturbed areas are permanently stabilized.

Design Criteria

See Figure 5A.2 on page 5A.5 for details.

	Swale A	Swale B
Drainage Area	<5 Ac	5-10 Ac
Bottom Width of Flow Channel	4 ft	6 ft
Depth of Flow Channel	1 ft	1 ft
Side Slopes	2:1 or flatter	2:1 or flatter
Grade	0.5% Min. 20% Max.	0.5% Min. 20% Max.

For drainage areas larger than 10 acres, refer to the Standard and Specification for Waterways on page 5B.11.

Stabilization

Stabilization of the swale shall be completed within 7 days of installation in accordance with the appropriate standard and specifications for vegetative stabilization or stabilization with mulch as determined by the time of year. The flow channel shall be stabilized as per the following criteria:

Type of Treatment	Channel Grade ¹	Flow Channel	
		A (<5 Ac.)	B (5-10 Ac)
1	0.5-3.0%	Seed & Straw Mulch	Seed & Straw Mulch
2	3.1-5.0%	Seed & Straw Mulch	Seed and cover with RECP, Sod, or lined with plastic or 2 in. stone
3	5.1-8.0%	Seed and cover with RECP, Sod, or line with plastic or 2 in. stone	Line with 4-8 in. or stone or Recycled Concrete Equivalent ² or geotextile
4	8.1-20%	Line with 4-8 in. stone or Recycled Concrete Equivalent ² or geotextile	Site Specific Engineering Design

¹ In highly erodible soils, as defined by the local approving agency, refer to the next higher slope grade for type of stabilization.

² Recycled Concrete Equivalent shall be concrete broken into the required size, and shall contain no steel reinforcement.

Outlet

Swale shall have an outlet that functions with a minimum of erosion, and dissipates runoff velocity prior to discharge off the site.

Runoff shall be conveyed to a sediment trapping device such as a sediment trap or sediment basin until the drainage area above the swale is adequately stabilized.

The on-site location may need to be adjusted to meet field conditions in order to utilize the most suitable outlet condition.

If a swale is used to divert clean water flows from entering a disturbed area, a sediment trapping device may not be needed.

**Figure 5A.2
Temporary Swale**

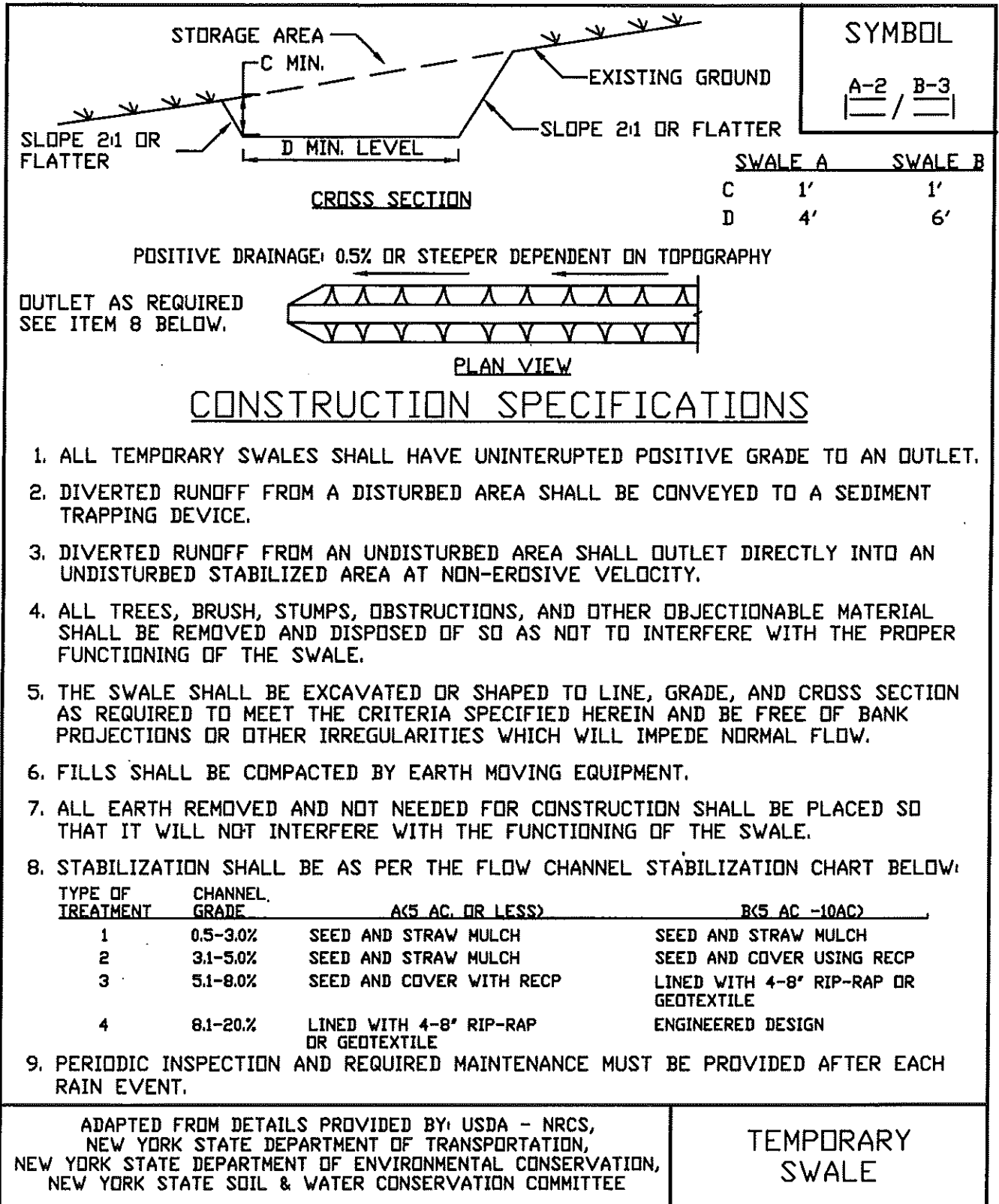

STANDARD AND SPECIFICATIONS FOR PERIMETER DIKE/SWALE



Definition

A temporary ridge of soil excavated from an adjoining swale located along the perimeter of the site or disturbed area.

Purpose

The purpose of a perimeter dike/swale is to prevent off site storm runoff from entering a disturbed area and to prevent sediment laden storm runoff from leaving the construction site or disturbed area.

Conditions Where Practice Applies

Perimeter dike/swale is constructed to divert flows from entering a disturbed area, or along tops of slopes to prevent flows from eroding the slope, or along base of slopes to direct sediment laden flows to a trapping device.

The perimeter dike/swale shall remain in place until the disturbed areas are permanently stabilized.

Design Criteria

See Figure 5A.3 on page 5A.8 for details.

The perimeter dike/swale shall not be constructed outside the property lines without obtaining legal easements from affected adjacent property owners. A design is not required for perimeter dike/swale. The following criteria shall be used:

Drainage area – Less than 2 acres (for drainage areas larger than 2 acres but less than 10 acres, see earth dike or temporary swale; for drainage areas larger than 10 acres, see standard and specifications for diversion).

Height – 18 inches minimum from bottom of swale to top of dike evenly divided between dike height and swale depth.

Bottom width of dike – 2 feet minimum.

Width of swale – 2 feet minimum.

Grade – Dependent upon topography, but shall have positive drainage (sufficient grade to drain) to an adequate outlet. Maximum allowable grade not to exceed 8 percent.

Stabilization – The disturbed area of the dike and swale shall be stabilized within 7 days of installation, in accordance with the standard and specifications for temporary swales.

Outlet

1. Perimeter dike/swale shall have a stabilized outlet.
2. Diverted runoff from a protected or stabilized upland area shall outlet directly onto an undisturbed stabilized area.
3. Diverted runoff from a disturbed or exposed upland area shall be conveyed to a sediment trapping device such as a sediment trap, sediment basin, or to an area protected by any of these practices.
4. The on-site location may need to be adjusted to meet field conditions in order to utilize the most suitable outlet.

**Figure 5A.3
Perimeter Dike/Swale**

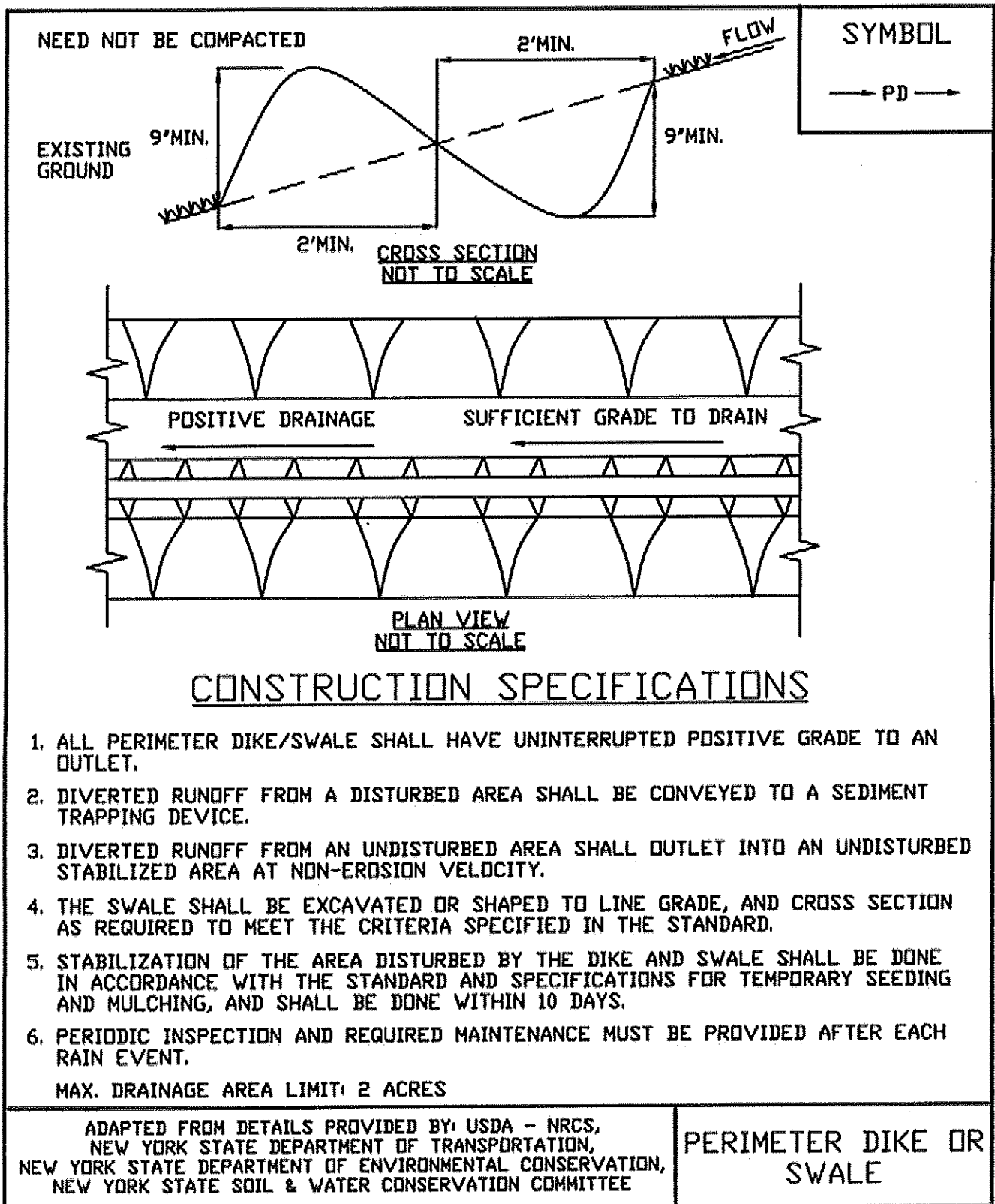

STANDARD AND SPECIFICATIONS FOR LEVEL SPREADER



Design Criteria

The design capacity shall be determined by estimating the peak flow from the 10-year storm. The drainage area shall be restricted to limit the maximum flows into the spreader to 30 cfs. The level spreader shall have the following minimum dimension:

Design Flow (cfs)	Minimum Entrance Width (ft.)	Depth (ft.)	End Width (ft.)	Length (ft.)
0-10	10	0.5	3	10
10-20	16	0.6	3	20
20-30	24	0.7	3	30

Definition

A temporary non-erosive outlet for concentrated runoff, constructed to disperse flow uniformly across a slope.

Purpose

To convert concentrated flow to sheet flow and release it uniformly over a stabilized area.

Conditions Where Practice Applies

Where sediment-free storm runoff can be released in sheet flow down a stabilized slope without causing erosion; where a level lip can be constructed without filling; where the area below the level lip is uniform with a slope of 10% or less and the runoff will not re-concentrate after release; and where no traffic will be allowed over spreader.

A transition section 20 feet in length shall be constructed from the width of the diversion or channel to the width of the spreader to ensure uniform outflow. This last transition section will blend the diversion grade to zero grade at the beginning of the spreader.

Construct the level lip in undisturbed soil to a uniform height and zeros grade over the length of the spreader. Protect the lip with an erosion resistant material or mat to prevent erosion and allow vegetation to become established.

The outlet area should be a generally smooth, well-vegetated areas no steeper than 10 percent.

See Figure 5A.5 on page 5A.14 for details.

Figure 5A.5
Level Spreader

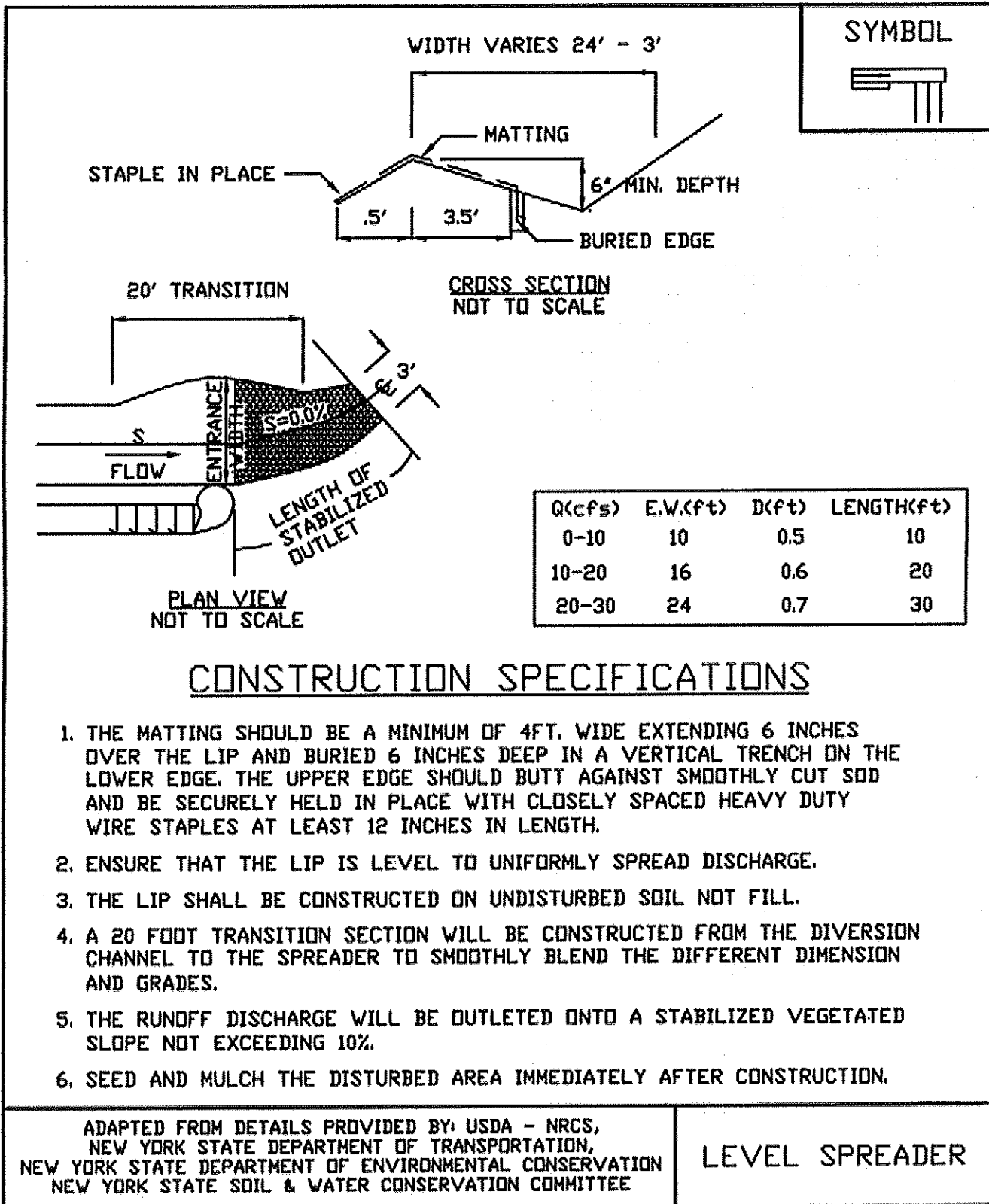

STANDARD AND SPECIFICATIONS FOR SILT FENCE



Definition

A temporary barrier of geotextile fabric installed on the contours across a slope used to intercept sediment laden runoff from small drainage areas of disturbed soil.

Purpose

The purpose of a silt fence is to reduce runoff velocity and effect deposition of transported sediment load. Limits imposed by ultraviolet stability of the fabric will dictate the maximum period the silt fence may be used (approximately one year).

Conditions Where Practice Applies

A silt fence may be used subject to the following conditions:

1. Maximum allowable slope lengths contributing runoff to a silt fence placed on a slope are:

Slope Steepness	Maximum Length (ft.)
2:1	25
3:1	50
4:1	75
5:1 or flatter	100

2. Maximum drainage area for overland flow to a silt fence shall not exceed ¼ acre per 100 feet of fence, with maximum ponding depth of 1.5 feet behind the fence; and
3. Erosion would occur in the form of sheet erosion; and
4. There is no concentration of water flowing to the barrier.

Design Criteria

Design computations are not required for installations of 1 month or less. Longer installation periods should be designed for expected runoff. All silt fences shall be placed as close to the areas as possible, but at least 10 feet from the toe of a slope to allow for maintenance and roll down. The area beyond the fence must be undisturbed or stabilized.

Sensitive areas to be protected by silt fence may need to be reinforced by using heavy wire fencing for added support to prevent collapse.

Where ends of filter cloth come together, they shall be overlapped, folded and stapled to prevent sediment bypass. A detail of the silt fence shall be shown on the plan. See Figure 5A.8 on page 5A.21 for details.

Criteria for Silt Fence Materials

1. Silt Fence Fabric: The fabric shall meet the following specifications unless otherwise approved by the appropriate erosion and sediment control plan approval authority. Such approval shall not constitute statewide acceptance.

Fabric Properties	Minimum Acceptable Value	Test Method
Grab Tensile Strength (lbs)	90	ASTM D1682
Elongation at Failure (%)	50	ASTM D1682

Mullen Burst Strength (PSI)	190	ASTM D3786
Puncture Strength (lbs)	40	ASTM D751 (modified)
Slurry Flow Rate (gal/min/sf)	0.3	
Equivalent Opening Size	40-80	US Std Sieve CW-02215
Ultraviolet Radiation Stability (%)	90	ASTM G-26

2. Fence Posts (for fabricated units): The length shall be a minimum of 36 inches long. Wood posts will be of sound quality hardwood with a minimum cross sectional area of 3.0 square inches. Steel posts will be standard T and U section weighing not less than 1.00 pound per linear foot.

3. Wire Fence (for fabricated units): Wire fencing shall be a minimum 14 gage with a maximum 6 in. mesh opening, or as approved.

4. Prefabricated Units: Envirofence, Geofab, or approved equal, may be used in lieu of the above method providing the unit is installed per details shown in Figure 5A.8.

Figure 5A.8
Silt Fence

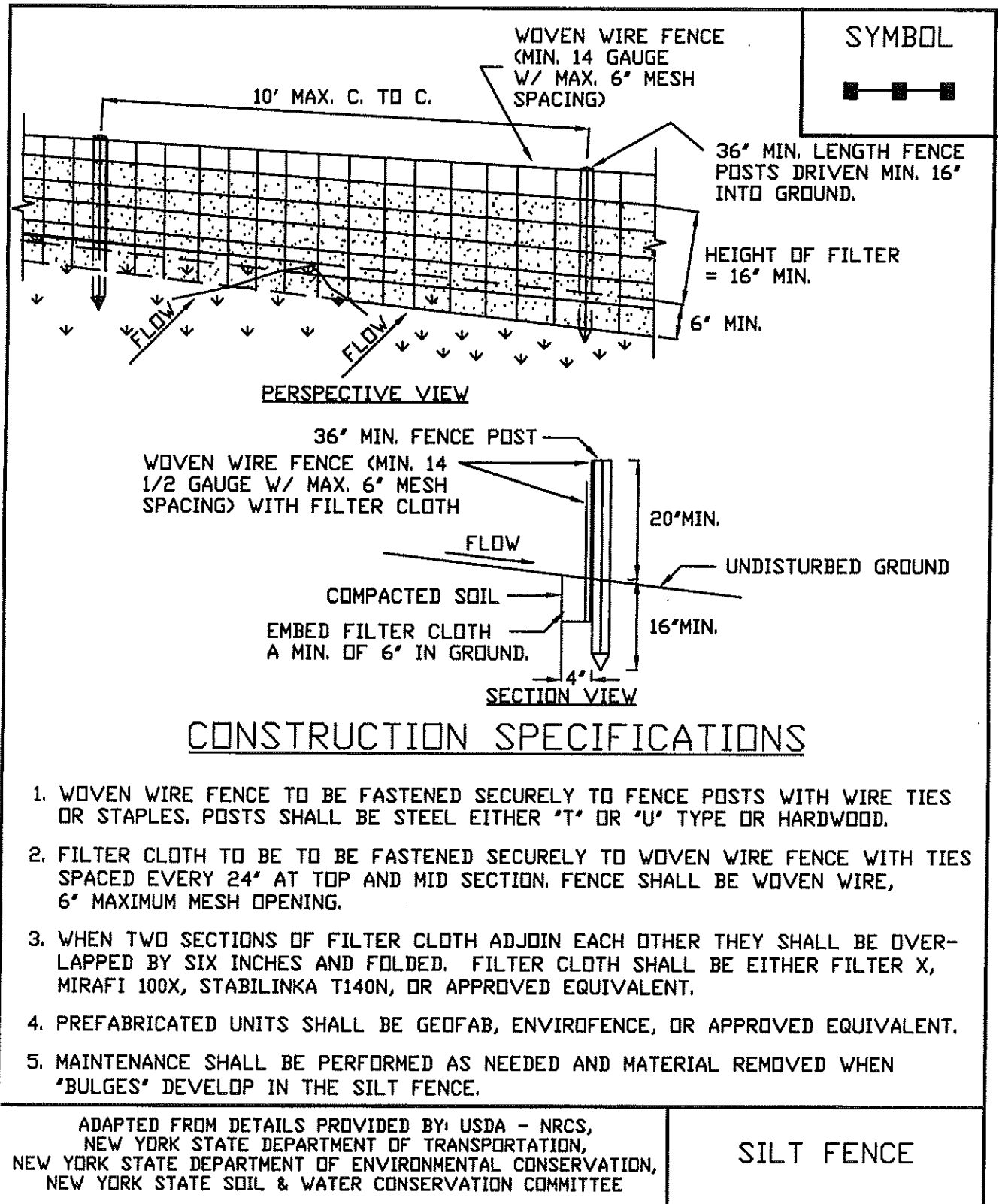

STANDARD AND SPECIFICATIONS FOR CHECK DAM



Definition

Small barriers or dams constructed of stone, bagged sand or gravel, or other durable material across a drainage way.

Purpose

To reduce erosion in a drainage channel by restricting the velocity of flow in the channel.

Condition Where Practice Applies

This practice is used as a temporary or emergency measure to limit erosion by reducing velocities in small open channels that are degrading or subject to erosion and where permanent stabilization is impractical due to short period of usefulness and time constraints of construction.

Design Criteria

Drainage Area: Maximum drainage area above the check dam shall not exceed two (2) acres.

Height: Not greater than 2 feet. Center shall be maintained 9 inches lower than abutments at natural ground elevation.

Side Slopes: Shall be 2:1 or flatter.

Spacing: The check dams shall be spaced as necessary in the channel so that the crest of the downstream dam is at the

elevation of the toe of the upstream dam. This spacing is equal to the height of the check dam divided by the channel slope.

Therefore:

$$S = h/s$$

Where:

S = spacing interval (ft.)
h = height of check dam (ft.)
s = channel slope (ft./ft.)

Example:

For a channel with a 4% slope and 2 ft. high stone check dams, they are spaced as follows:

$$S = \frac{2 \text{ ft.}}{.04 \text{ ft./ft.}} = 50 \text{ ft.}$$

Stone size: Use a well graded stone matrix 2 to 9 inches in size (NYS – DOT Light Stone Fill meets these requirements).

The overflow of the check dams will be stabilized to resist erosion that might be caused by the check dam. See Figure 5A.9 on page 5A.24 for details.

Check dams should be anchored in the channel by a cutoff trench 1.5 ft. wide and 0.5 ft. deep and lined with filter fabric to prevent soil migration.

Maintenance

The check dams should be inspected after each runoff event. Correct all damage immediately. If significant erosion has occurred between structures, a liner of stone or other suitable material should be installed in that portion of the channel.

Remove sediment accumulated behind the dam as needed to allow channel to drain through the stone check dam and prevent large flows from carrying sediment over the dam. Replace stones as needed to maintain the design cross section of the structures.

Figure 5A.9
Check Dam

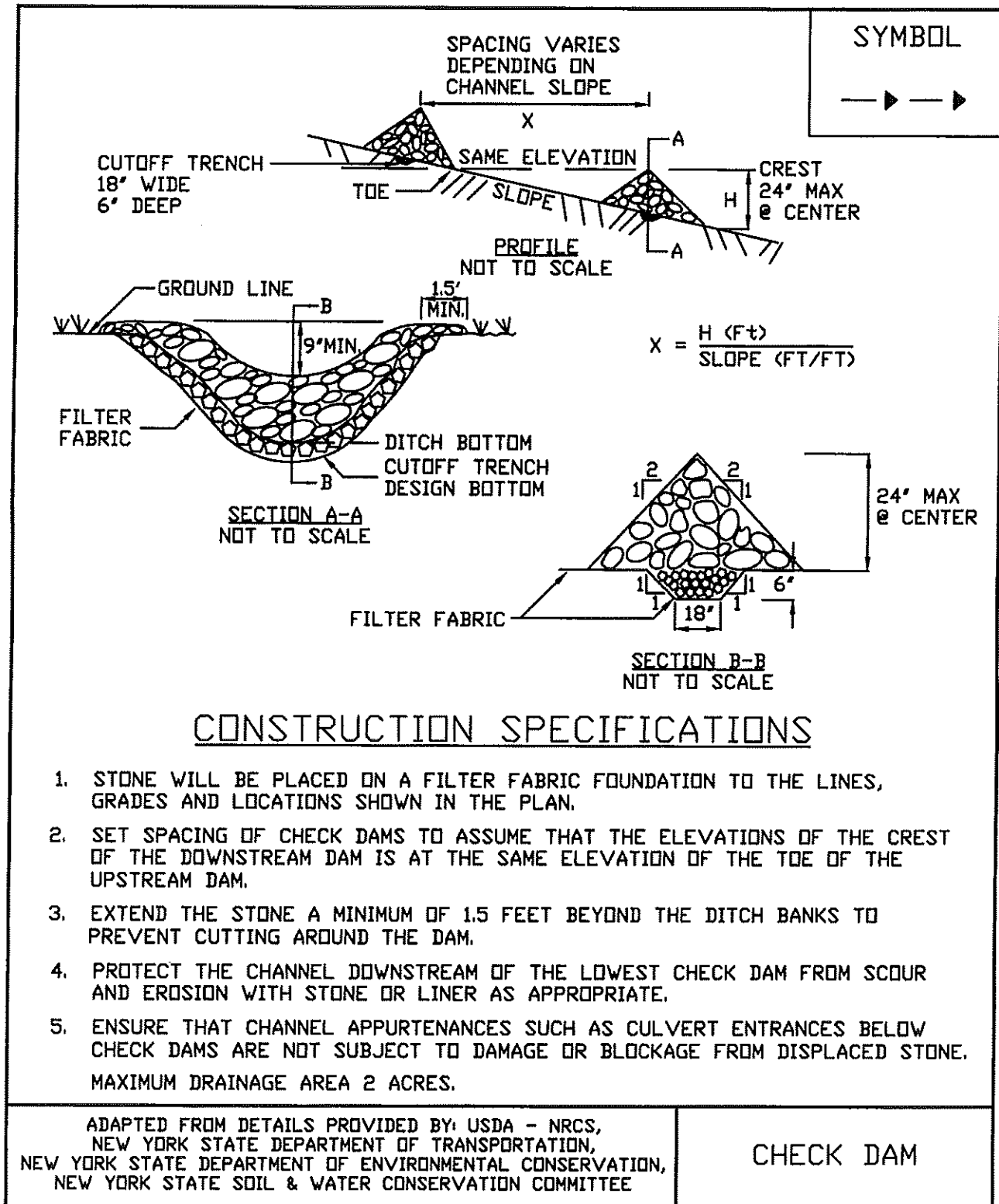

STANDARD AND SPECIFICATIONS FOR STORM DRAIN INLET PROTECTION



Definition

A temporary, somewhat permeable barrier, installed around inlets in the form of a fence, berm or excavation around an opening, trapping water and thereby reducing the sediment content of sediment laden water by settling.

Purpose

To prevent heavily sediment laden water from entering a storm drain system through inlets.

Conditions Where Practice Applies

This practice shall be used where the drainage area to an inlet is disturbed, it is not possible to temporarily divert the storm drain outfall into a trapping device, and watertight blocking of inlets is not advisable. **It is not to be used in place of sediment trapping devices.** This may be used in conjunction with storm drain diversion to help prevent siltation of pipes installed with low slope angle.

Types of Storm Drain Inlet Practices

There are four (4) specific types of storm drain inlet protection practices that vary according to their function, location, drainage area, and availability of materials:

- I. Excavated Drop Inlet Protection
- II. Fabric Drop Inlet Protection
- III. Stone & Block Drop Inlet Protection
- IV. Curb Drop Inlet Protection

Design Criteria

Drainage Area – The drainage area for storm drain inlets shall not exceed one acre. The crest elevations of these practices shall provide storage and minimize bypass flow.

Type I – Excavated Drop Inlet Protection

See details for Excavated Drop Inlet Protection in Figure 5A.11 on page 5A.29.

Limit the drainage area to the inlet device to 1 acre. Excavated side slopes shall be no steeper than 2:1. The minimum depth shall be 1 foot and the maximum depth 2 feet as measured from the crest of the inlet structure. Shape the excavated basin to fit conditions with the longest dimension oriented toward the longest inflow area to provide maximum trap efficiency. The capacity of the excavated basin should be established to contain 900 cubic feet per acre of disturbed area. Weep holes, protected by fabric and stone, should be provided for draining the temporary pool.

Inspect and clean the excavated basin after every storm. Sediment should be removed when 50 percent of the storage volume is achieved. This material should be incorporated into the site in a stabilized manner.

Type II – Fabric Drop Inlet Protection

See Figure 5A.12 for details on Filter Fabric Drop Inlet Protection on page 5A.30.

Limit the drainage area to 1 acre per inlet device. Land area slope immediately surrounding this device should not exceed 1 percent. The maximum height of the fabric above the inlet crest shall not exceed 1.5 feet unless reinforced.

The top of the barrier should be maintained to allow overflow to drop into the drop inlet and not bypass the inlet to unprotected lower areas. Support stakes for fabric shall be a minimum of 3 feet long, spaced a maximum 3 feet apart. They should be driven close to the inlet so any overflow drops into the inlet and not on the unprotected soil. Improved performance and sediment storage volume can be obtained by excavating the area.

Inspect the fabric barrier after each rain event and make repairs as needed. Remove sediment from the pool area as

necessary with care not to undercut or damage the filter fabric. Upon stabilization of the drainage area, remove all materials and unstable sediment and dispose of properly. Bring the adjacent area of the drop inlet to grade, smooth and compact and stabilize in the appropriate manner to the site.

If straw bales are used in lieu of filter fabric, they should be placed tight with the cut edge adhering to the ground at least 3 inches below the elevation of the drop inlet. Two anchor stakes per bale shall be driven flush to bale surface. Straw bales will be replaced every 4 months until the area is stabilized.

Type III – Stone and Block Drop Inlet Protection

See Figure 5A.13 for details on Stone and Block Drop Inlet Protection on page 5A.31.

Limit the drainage area to 1 acre at the drop inlet. The stone barrier should have a minimum height of 1 foot and a maximum height of 2 feet. Do not use mortar. The height should be limited to prevent excess ponding and bypass flow.

Recess the first course of blocks at least 2 inches below the crest opening of the storm drain for lateral support. Subsequent courses can be supported laterally if needed by placing a 2x4 inch wood stud through the block openings perpendicular to the course. The bottom row should have a few blocks oriented so flow can drain through the block to dewater the basin area.

The stone should be placed just below the top of the blocks on slopes of 2:1 or flatter. Place hardware cloth or wire mesh with ½ inch openings over all block openings to hold stone in place.

As an optional design, the concrete blocks may be omitted and the entire structure constructed of stone, ringing the outlet (“doughnut”). The stone should be kept at a 3:1 slope toward the inlet to keep it from being washed into the inlet.

A level area 1 foot wide and four inches below the crest will further prevent wash. Stone on the slope toward the inlet should be at least 3 inches in size for stability and 1 inch or smaller away from the inlet to control flow rate. The elevation of the top of the stone crest must be maintained 6 inches lower than the ground elevation down slope from the inlet to ensure that all storm flows pass over the stone into the storm drain and not past the structure. Temporary diking should be used as necessary to prevent bypass flow.

The barrier should be inspected after each rain event and repairs made where needed. Remove sediment as necessary to provide for accurate storage volume for subsequent rains. Upon stabilization of contributing drainage area, remove all materials and any unstable soil and dispose of properly.

Bring the disturbed area to proper grade, smooth, compact and stabilized in a manner appropriate to the site.

Type IV – Curb Drop Inlet Protection

See Figure 5A. 14 for details on Curb Drop Inlet Protection on page 5A.32.

The drainage area should be limited to 1 acre at the drop inlet. The wire mesh must be of sufficient strength to support the filter fabric and stone with the water fully impounded against it. Stone is to be 2 inches in size and clean. The filter fabric must be of a type approved for this purpose with an equivalent opening size (EOS) of 40-85. The protective structure will be constructed to extend beyond the inlet 2 feet in both directions. Assure that storm flow does not bypass the inlet by installing temporary dikes (such as sand bags) directing flow into the inlet. Make sure that the overflow weir is stable. Traffic safety shall be integrated with the use of this practice.

The structure should be inspected after every storm event. Any sediment should be removed and disposed of on the site. Any stone missing should be replaced. Check materials for proper anchorage and secure as necessary.

**Figure 5A.11
Excavated Drop Inlet Protection**

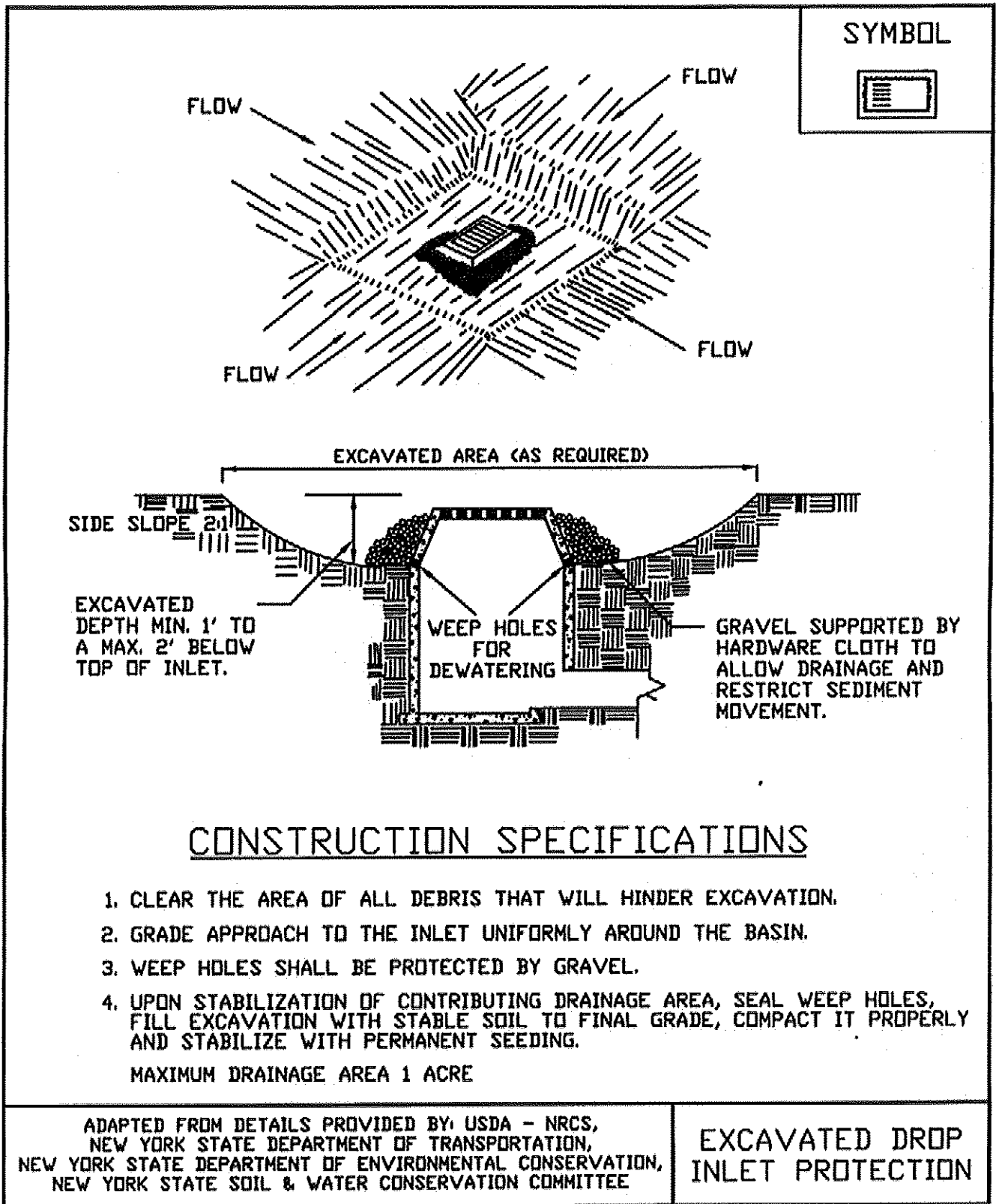

Figure 5A.12
Filter Fabric Drop Inlet Protection

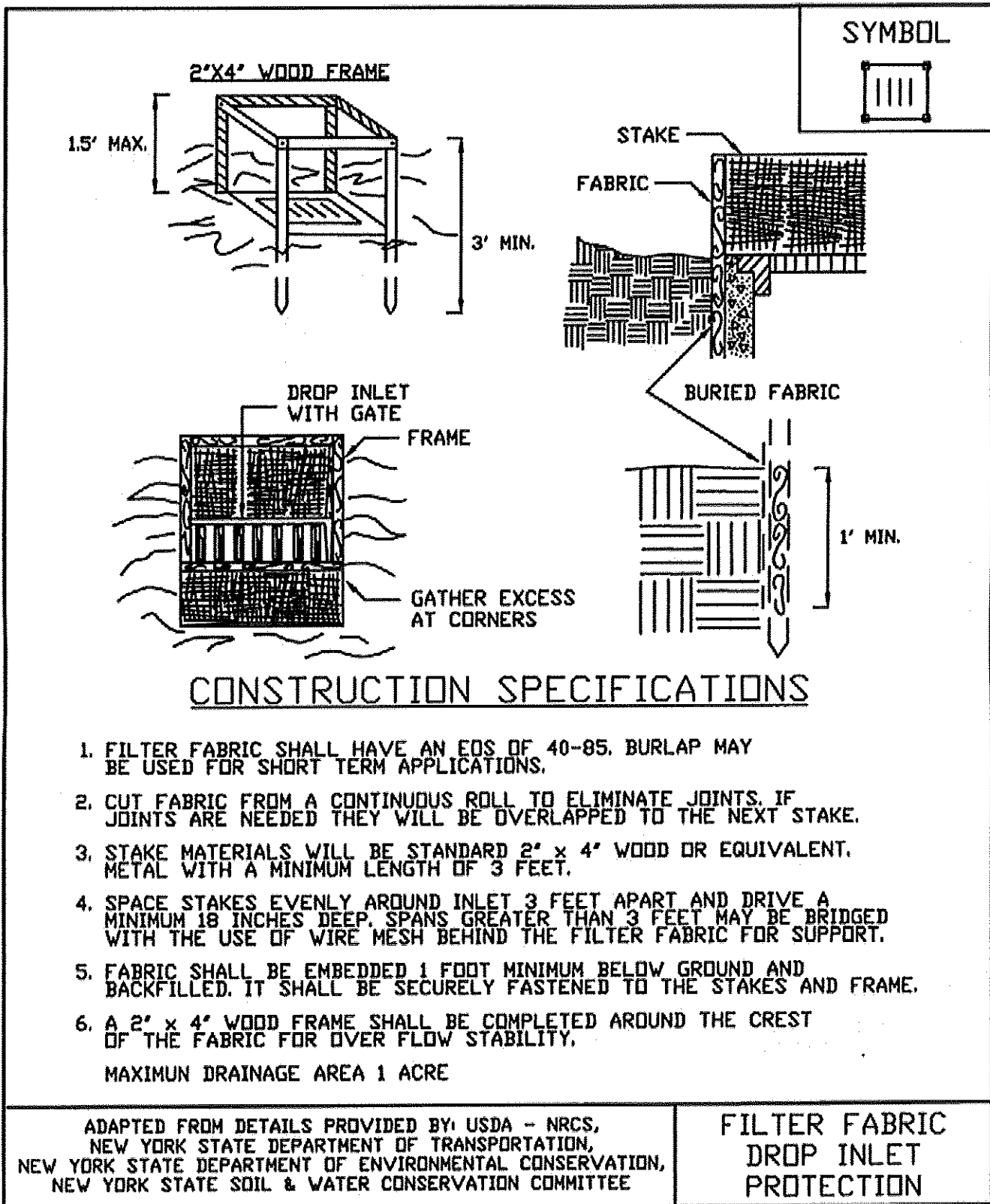
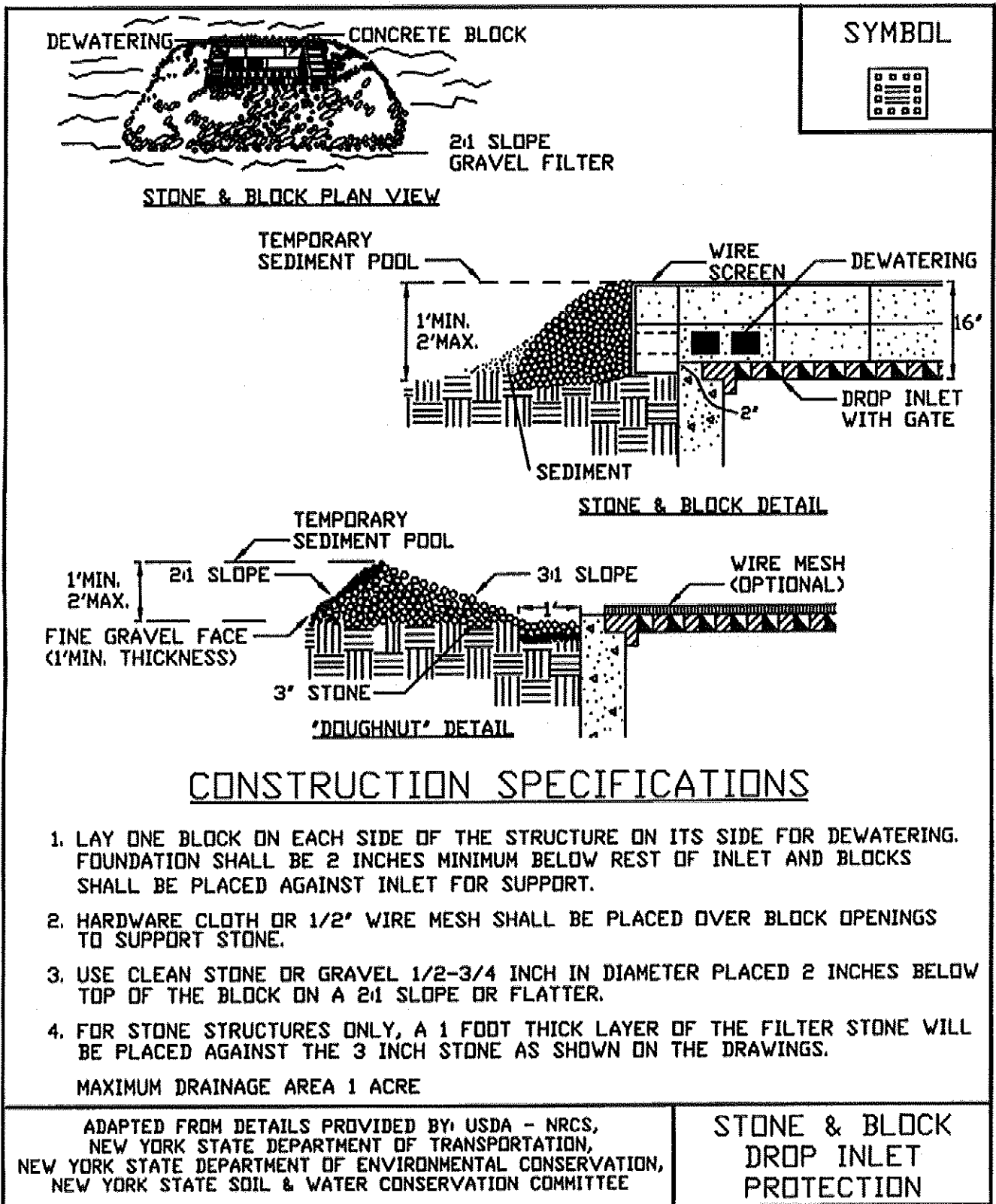
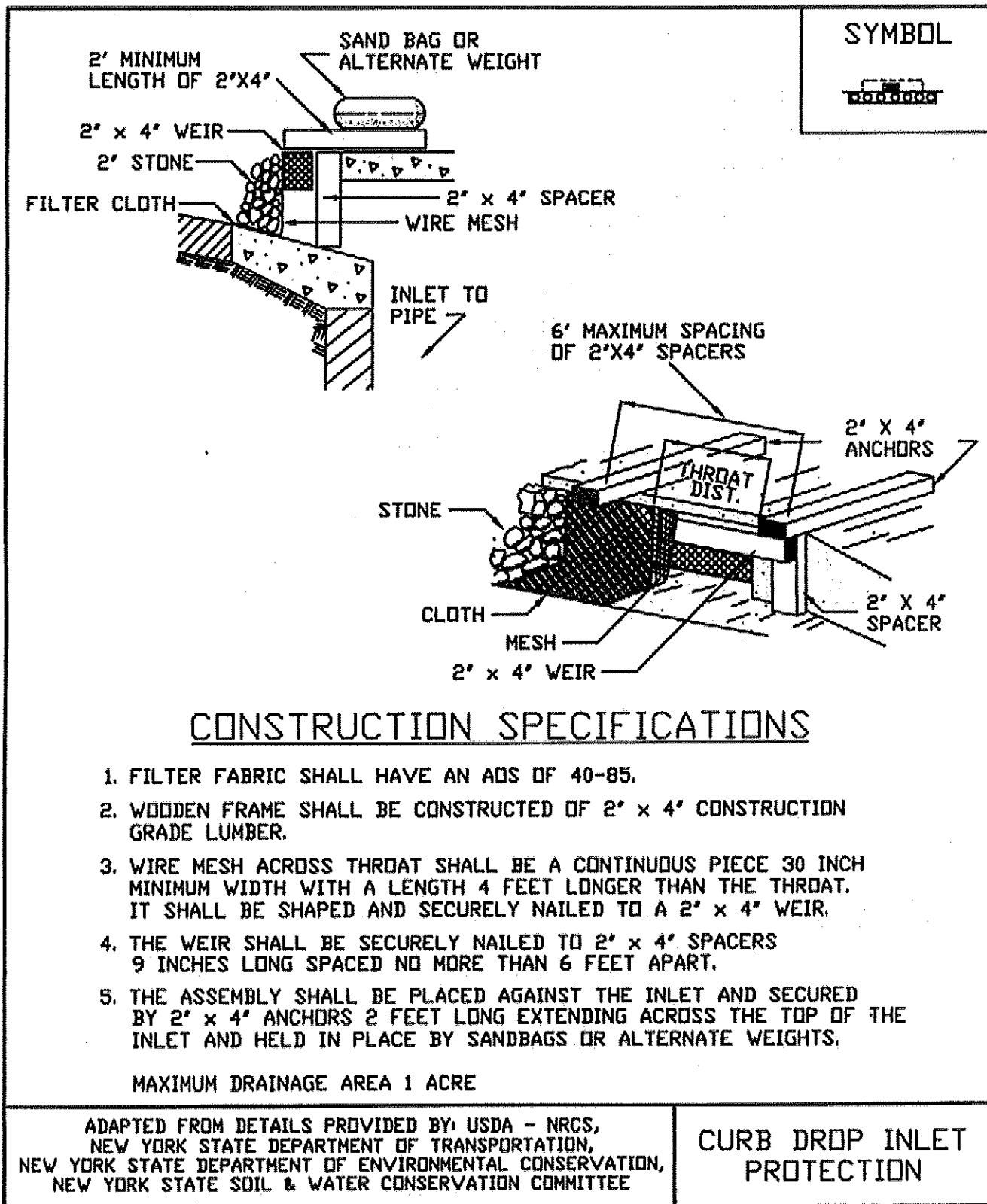

Figure 5A.13
Stone & Block Drop Inlet Protection



**Figure 5A.14
Curb Drop Inlet Protection**



STANDARD AND SPECIFICATIONS FOR SEDIMENT TRAP



Definition

A temporary sediment control device formed by excavation and/or embankment to intercept sediment laden runoff and retain the sediment.

Purpose

The purpose of the structure is to intercept sediment-laden runoff and trap the sediment in order to protect drainage ways, properties, and rights-of-way below the sediment trap from sedimentation.

Conditions Where Practice Applies

A sediment trap is usually installed in a drainage way, at a storm drain inlet, or other points of collection from a disturbed area.

Sediment traps should be used to artificially break up the natural drainage area into smaller sections where a larger device (sediment basin) would be less effective.

Design Criteria

If any of the design criteria presented here cannot be met, see Standard and Specification for Sediment Basin on page 5A.49.

Drainage Area

The drainage area for sediment traps shall be in accordance with the specific type of sediment trap used (Type I through V).

Location

Sediment traps shall be located so that they can be installed

prior to grading or filling in the drainage area they are to protect. Traps must not be located any closer than 20 feet from a proposed building foundation if the trap is to function during building construction. Locate traps to obtain maximum storage benefit from the terrain and for ease of cleanout and disposal of the trapped sediment.

Trap Size

The volume of a sediment trap as measured at the elevation of the crest of the outlet shall be at least 3,600 cubic feet per acre of drainage area. The volume of a constructed trap shall be calculated using standard mathematical procedures. The volume of a natural sediment trap may be approximated by the equation: Volume (cu.ft.) = 0.4 x surface area (sq.ft.) x maximum depth (ft.).

Trap Cleanout

Sediment shall be removed and the trap restored to the original dimensions when the sediment has accumulated to ½ of the design depth of the trap. Sediment removed from the trap shall be deposited in a protected area and in such a manner that it will not erode.

Embankment

All embankments for sediment traps shall not exceed five (5) feet in height as measured at the low point of the original ground along the centerline of the embankment. Embankments shall have a minimum four (4) foot wide top and side slopes of 2:1 or flatter. The embankment shall be compacted by traversing with equipment while it is being constructed. The embankment shall be stabilized with seed and mulch as soon as it is completed.

The elevation of the top of any dike directing water to any sediment trap will equal or exceed the maximum height of the outlet structure along the entire length of the trap.

Excavation

All excavation operations shall be carried out in such a manner that erosion and water pollution shall be minimal. Excavated portions of sediment traps shall have 1:1 or flatter slopes.

Outlet

The outlet shall be designed, constructed, and maintained in such a manner that sediment does not leave the trap and that erosion at or below the outlet does not occur.

Sediment traps must outlet onto stabilized (preferable undisturbed) ground, into a watercourse, stabilized channel, or into a storm drain system. Distance between inlet and outlet should be maximized to the longest length practicable.

Trap Details Needed on Erosion and Sediment Control Plans

Each trap shall be delineated on the plans in such a manner that it will not be confused with any other features. Each trap on a plan shall indicate all the information necessary to properly construct and maintain the structure. If the drawings are such that this information cannot be delineated on the drawings, then a table shall be developed. If a table is developed, then each trap on a plan shall have a number and the numbers shall be consecutive.

The following information shall be shown for each trap in a summary table format on the plans.

1. Trap number
2. Type of trap
3. Drainage area
4. Storage required
5. Storage provided (if applicable)
6. Outlet length or pipe sizes
7. Storage depth below outlet or cleanout elevation
8. Embankment height and elevation (if applicable)

Type of Sediment Traps

There are five (5) specific types of sediment traps which vary according to their function, location, or drainage area.

- I. Pipe Outlet Sediment Trap
- II. Grass Outlet Sediment Trap
- III. Catch Basin Sediment Trap
- IV. Stone Outlet Sediment Trap
- V. Riprap Outlet Sediment Trap

I. Pipe Outlet Sediment Trap

A Pipe Outlet Sediment Trap consists of a trap formed by embankment or excavation. The outlet for the trap is through a perforated riser and a pipe through the embankment. The outlet pipe and riser shall be made of steel, corrugated metal or other suitable material. The top of the embankment shall be at least 1 ½ feet above the crest of the riser. The top 2/3 of the riser shall be perforated with one (1) inch nominal diameter holes or slits spaced six (6) inches vertically and horizontally placed in the concave portion of the corrugated pipe.

No holes or slits will be allowed within six (6) inches of the top of the horizontal barrel. All pipe connections shall be watertight. The riser shall be wrapped with ½ to ¼ inch hardware cloth wire then wrapped with filter cloth with a sieve size between #40-80 and secured with strapping or

connecting band at the top and bottom of the cloth. The cloth shall cover an area at least six (6) inches above the highest hole and six (6) inches below the lowest hole. The top of the riser pipe shall not be covered with filter cloth. The riser shall have a base with sufficient weight to prevent flotation of the riser. Two approved bases are:

1. A concrete base 12 in. thick with the riser embedded 9 in. into the concrete base, or
2. One quarter inch, minimum, thick steel plate attached to the riser by a continuous weld around the circumference of the riser to form a watertight connection. The plate shall have 2.5 feet of stone, gravel, or earth placed on it to prevent flotation. In either case, each side of the square base measurement shall be the riser diameter plus 24 inches.

Pipe outlet sediment traps shall be limited to a five (5) acre maximum drainage area. Pipe outlet sediment traps may be interchangeable in the field with stone outlet or riprap sediment traps provided that these sediment traps are constructed in accordance with the detail and specifications for that trap.

Select pipe diameter from the following table:

Minimum Sizes

Barrel Diameter ¹ (in.)	Riser Diameter ¹ (in.)	Maximum Drainage Area (ac.)
12	15	1
15	18	2
18	21	3
21	24	4
21	27	5

¹ Barrel diameter may be same size as riser diameter.

See details for Pipe Outlet Sediment Trap ST-I in Figure 5A.16 (1) and 5A.16 (2) on pages 5A.38 and 5A.39.

II. Grass Outlet Sediment Trap

A Grass Outlet Sediment Trap consists of a trap formed by excavating the earth to create a holding area. The trap has a discharge point over natural existing grass. The outlet crest width (feet) shall be equal to four (4) times the drainage area (acres) with a minimum width of four (4) feet. The outlet shall be free of any restrictions to flow. The outlet lip must remain undisturbed and level. The volume of this trap shall be computed at the elevation of the crest of the outlet. Grass outlet sediment traps shall be limited to a five (5) acre maximum drainage area.

See details for Grass Outlet Sediment Trap ST-II in Figure 5A.17 on page 5A.40.

III. Catch Basin Sediment Trap

A Catch Basin Sediment Trap consists of a basin formed by excavation on natural ground that discharges through an opening in a storm drain inlet structure. This opening can either be the inlet opening or a temporary opening made by omitting bricks or blocks in the inlet.

A yard drain inlet or an inlet in the median strip of a dual highway could use the inlet opening for the type outlet. The trap should be out of the roadway so as not to interfere with future compaction or construction. Placing the trap on the opposite side of the opening and diverting water from the roadway to the trap is one means of doing this. Catch basin sediment traps shall be limited to a three (3) acre maximum drainage area. The volume of this trap is measured at the elevation of the crest of the outlet (invert of the inlet opening).

See details for Catch Basin Sediment Trap ST-III in Figure 5A.18 on page 5A.41.

IV. Stone Outlet Sediment Trap

A Stone Outlet Sediment Trap consists of a trap formed by an embankment or excavation. The outlet of this trap is over a stone section placed on level ground. The minimum length (feet) of the outlet shall be equal to four (4) times the drainage area (acres).

Required storage shall be 3,600 cubic feet per acre of drainage area.

The outlet crest (top of stone in weir section) shall be level, at least one (1) foot below top of embankment and no more than one (1) foot above ground beneath the outlet. Stone used in the outlet shall be small riprap (4 in. x 8 in.). To provide more efficient trapping effect, a layer of filter cloth should be embedded one (1) foot back into the upstream face of the outlet stone or a one (1) foot thick layer of two (2) inch or finer aggregate shall be placed on the upstream face of the outlet.

Stone Outlet Sediment Traps may be interchangeable in the field with pipe or riprap outlet sediment traps provided they are constructed in accordance with the detail and specifications for those traps. Stone outlet sediment traps shall be limited to a five (5) acre maximum drainage area.

See details for Stone Outlet Sediment Trap ST-IV in Figure 5A.19 on page 5A.42.

V. Riprap Outlet Sediment Trap

A Riprap Outlet Sediment Trap consists of a trap formed by an excavation and embankment. The outlet for this trap

shall be through a partially excavated channel lined with riprap. This outlet channel shall discharge onto a stabilized area or to a stable watercourse. The riprap outlet sediment trap may be used for drainage areas of up to a maximum of 15 acres.

Design Criteria for Riprap Outlet Sediment Trap

1. The total contributing drainage area (disturbed or undisturbed either on or off the developing property) shall not exceed 15 acres.
2. The storage needs for this trap shall be computed using 3600 cubic feet of required storage for each acre of drainage area. The storage volume provided can be figured by computing the volume of storage area available behind the outlet structure up to an elevation of one (1) foot below the level weir crest.
3. The maximum height of embankment shall not exceed five (5) feet.
4. The elevation of the top of any dike directing water to a riprap outlet sediment trap will equal or exceed the minimum elevation of the embankment along the entire length of this trap.

Riprap Outlet Sediment Trap ST-V
(for Stone Lined Channel)

Contributing Drainage Area (ac.)	Depth of Channel (a) (ft.)	Length of Weir (b) (ft.)
1	1.5	4.0
2	1.5	5.0
3	1.5	6.0
4	1.5	10.0
5	1.5	12.0
6	1.5	14.0
7	1.5	16.0
8	2.0	10.0
9	2.0	10.0
10	2.0	12.0
11	2.0	14.0
12	2.0	14.0
13	2.0	16.0
14	2.0	16.0
15	2.0	18.0

See details for Riprap Outlet Sediment Trap ST-V on Figures 5A.20(1) and 5A.20(2) on pages 5A.43 and 5A.44.

Optional Dewatering Methods

Optional dewatering devices may be designed for use with sediment traps. Included are two methods, which may be used. See Figure 5A.21 on page 5A.45 for details.

Figure 5A.16(1)
Pipe Outlet Sediment Trap: ST-I

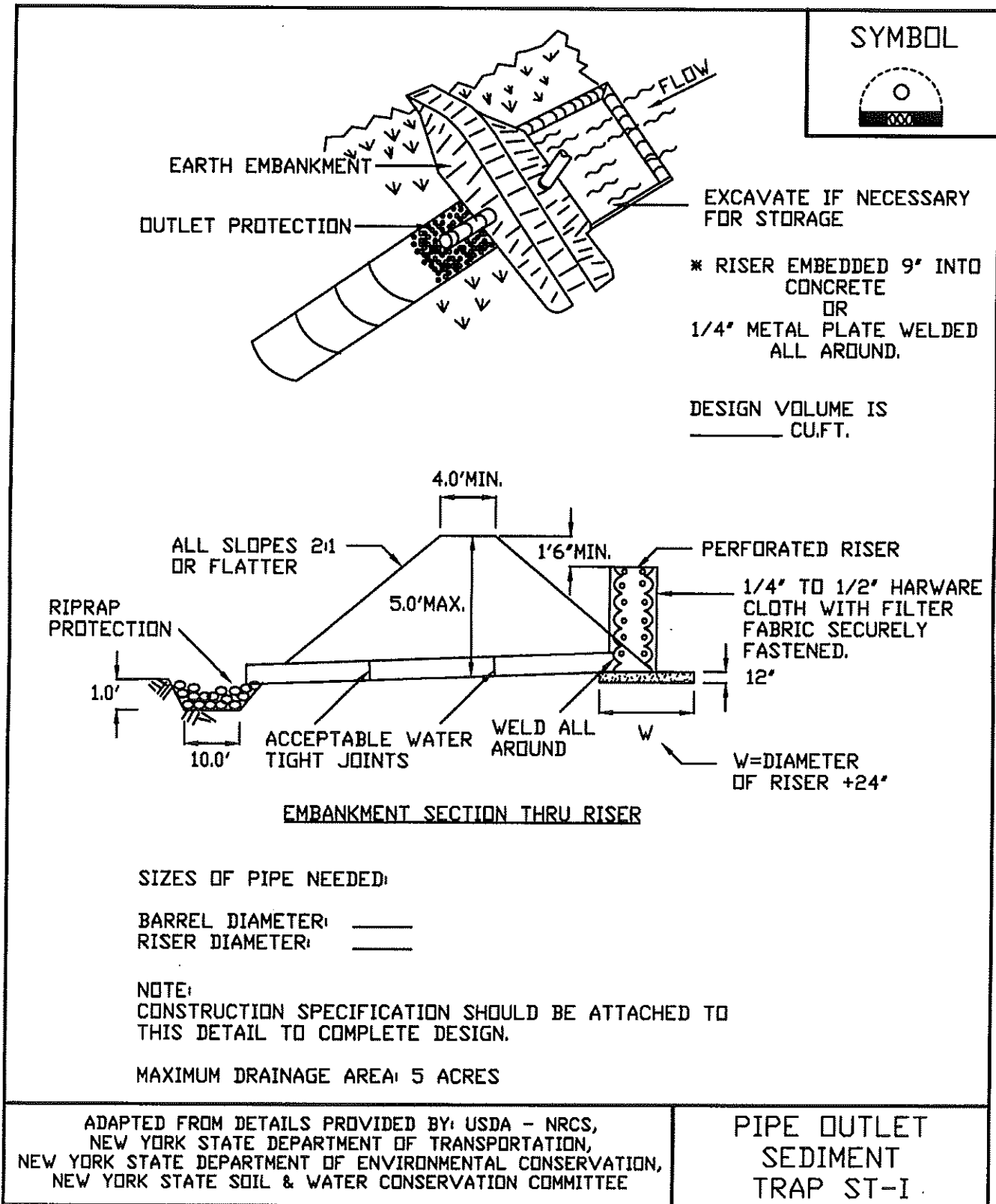

Figure 5A.16(2)
Pipe Outlet Sediment Trap: ST-I—Construction Specifications

<p style="font-size: 1.2em; margin: 0;"><u>CONSTRUCTION SPECIFICATIONS</u></p> <ol style="list-style-type: none"> 1. AREA UNDER EMBANKMENT SHALL BE CLEARED, GRUBBED AND STRIPPED OF ANY VEGETATION AND ROOT MAT. THE POOL AREA SHALL BE CLEARED. 2. THE FILL MATERIAL FOR THE EMBANKMENT SHALL BE FREE OF ROOTS OR OTHER WOODY VEGETATION AS WELL AS OVER-SIZED STONES, ROCKS, ORGANIC MATERIAL, OR OTHER OBJECTIONABLE MATERIAL. THE EMBANKMENT SHALL BE COMPACTED BY TRAVERSING WITH EQUIPMENT WHILE IT IS BEING CONSTRUCTED. 3. VOLUME OF SEDIMENT STORAGE SHALL BE 3600 CUBIC FEET PER ACRE OF CONTRIBUTORY DRAINAGE. 4. SEDIMENT SHALL BE REMOVED AND TRAP RESTORED TO ITS ORIGINAL DIMENSIONS WHEN THE SEDIMENT HAS ACCUMULATED TO 1/2 THE DESIGN DEPTH OF THE TRAP. REMOVED SEDIMENT SHALL BE DEPOSITED IN A SUITABLE AREA AND STABILIZED. 5. THE STRUCTURE SHALL BE INSPECTED AFTER EACH RAIN AND REPAIRS MADE AS NEEDED. 6. CONSTRUCTION OPERATIONS SHALL BE CARRIED OUT IN SUCH A MANNER THAT EROSION AND SEDIMENT ARE CONTROLLED. 7. THE STRUCTURE SHALL BE REMOVED AND AREA STABILIZED WHEN THE DRAINAGE AREA HAS BEEN PROPERLY STABILIZED. 8. ALL FILL SLOPES SHALL BE 2:1 OR FLATTER; CUT SLOPES 1:1 OR FLATTER. 9. ALL PIPE CONNECTIONS SHALL BE WATERTIGHT. 10. THE TOP 2/3 OF THE RISER SHALL BE PERFORATED WITH ONE (1) INCH DIAMETER HOLES OR SLITS SPACED SIX (6) INCHES VERTICALLY AND HORIZONTALLY AND PLACED IN THE CONCAVE PORTION OF PIPE. NO HOLES WILL BE ALLOWED WITHIN SIX (6) INCHES OF THE HORIZONTAL BARREL. 11. THE RISER SHALL BE WRAPPED WITH 1/4 TO 1/2 INCH HARDWARE CLOTH WIRE THEN WRAPPED WITH FILTER CLOTH (HAVING AN EQUIVALENT SIEVE SIZE OF 40-80). THE FILTER CLOTH SHALL EXTEND SIX (6) INCHES ABOVE THE HIGHEST HOLE AND SIX (6) INCHES BELOW THE LOWEST HOLE. WHERE ENDS OF THE FILTER CLOTH COME TOGETHER, THEY SHALL BE OVER-LAPPED, FOLDED AND STAPLED TO PREVENT BYPASS. 12. STRAPS OR CONNECTING BANDS SHALL BE USED TO HOLD THE FILTER CLOTH AND WIRE FABRIC IN PLACE. THEY SHALL BE PLACED AT THE TOP AND BOTTOM OF THE CLOTH. 13. FILL MATERIAL AROUND THE PIPE SPILLWAY SHALL BE HAND COMPACTED IN FOUR (4) INCH LAYERS. A MINIMUM OF TWO (2) FEET OF HAND COMPACTED BACKFILL SHALL BE PLACED OVER THE PIPE SPILLWAY BEFORE CROSSING IT WITH CONSTRUCTION EQUIPMENT. 14. THE RISER SHALL BE ANCHORED WITH EITHER A CONCRETE BASE OR STEEL PLATE BASE TO PREVENT FLOTATION. FOR CONCRETE BASED THE DEPTH SHALL BE TWELVE (12) INCHES WITH THE RISER EMBEDDED NINE (9) INCHES. A 1/4 INCH MINIMUM THICKNESS STEEL PLATE SHALL BE ATTACHED TO THE RISER BY A CONTINUOUS WELD AROUND THE BOTTOM TO FORM A WATERTIGHT CONNECTION AND THEN PLACE TWO (2) FEET OF STONE, GRAVEL, OR TAMPED EARTH ON THE PLATE. 	<p style="margin: 0;">SYMBOL</p> 
<p style="font-size: 0.8em; margin: 0;">ADAPTED FROM DETAILS PROVIDED BY: USDA - NRCS, NEW YORK STATE DEPARTMENT OF TRANSPORTATION, NEW YORK STATE DEPARTMENT OF ENVIRONMENTAL CONSERVATION, NEW YORK STATE SOIL & WATER CONSERVATION COMMITTEE</p>	<p style="font-size: 1.1em; margin: 0;">PIPE OUTLET SEDIMENT TRAP ST-I</p>

Figure 5A.17
Grass Outlet Sediment Trap: ST-II

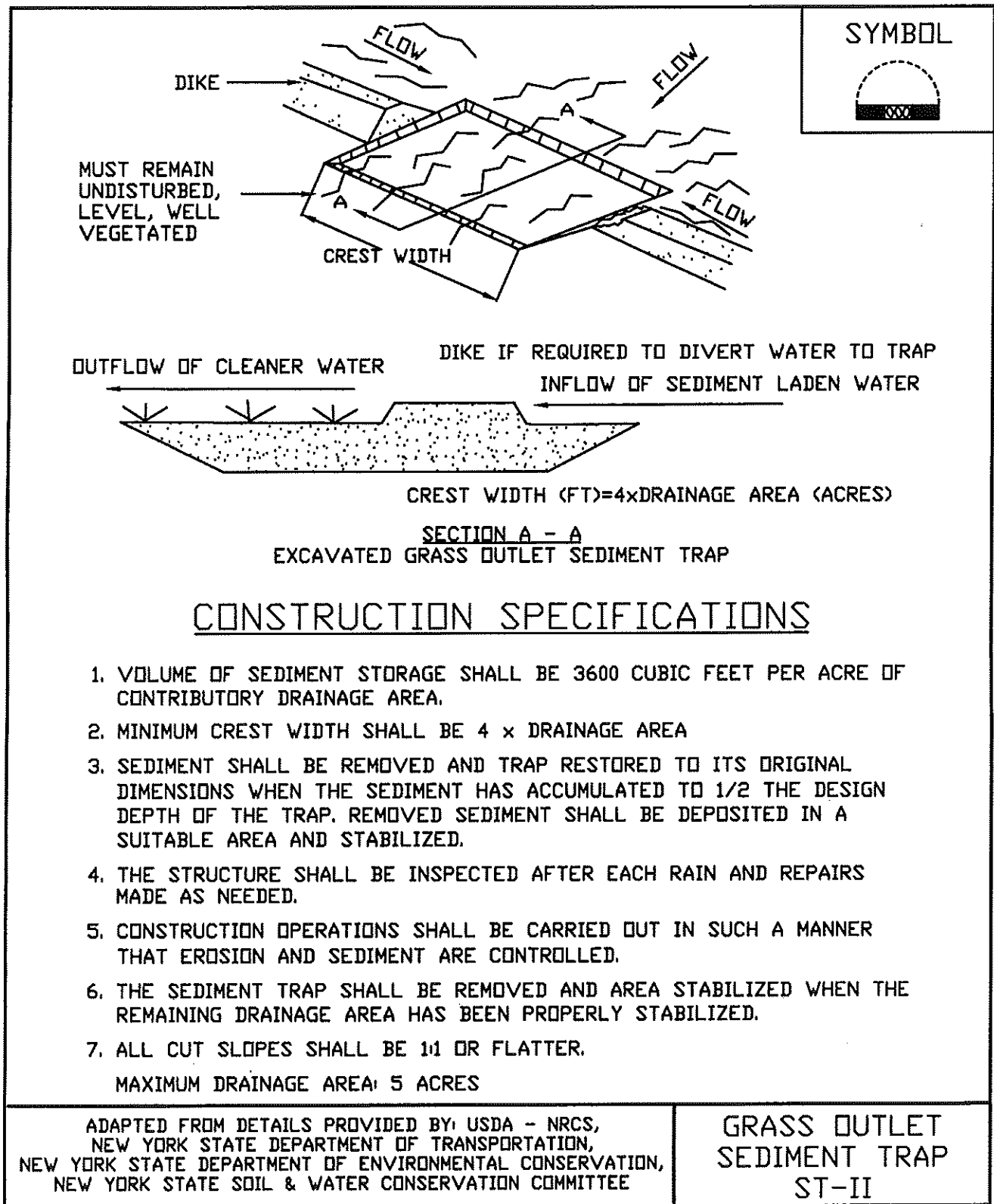

Figure 5A.18
Catch Basin Sediment Trap: ST-III

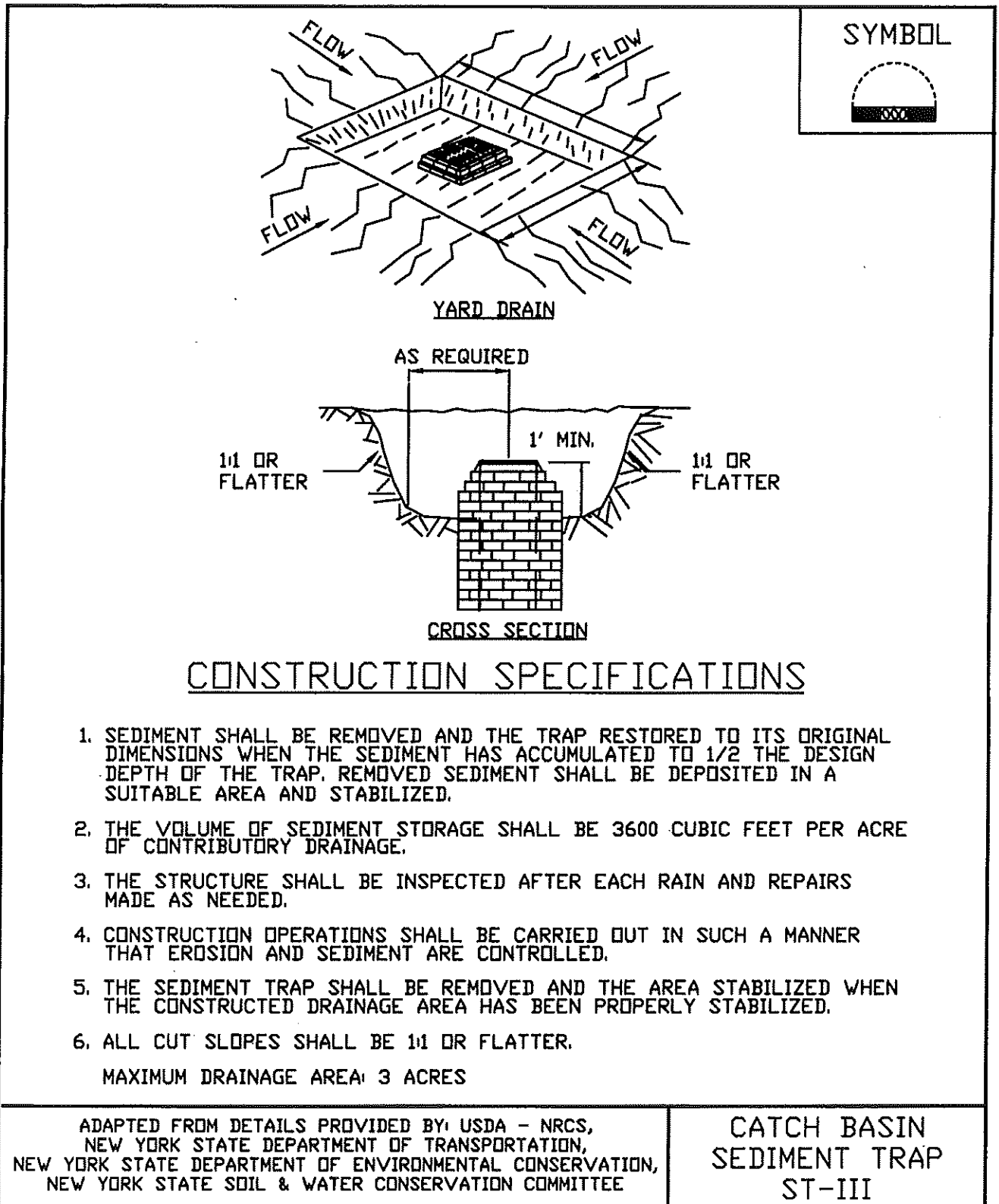
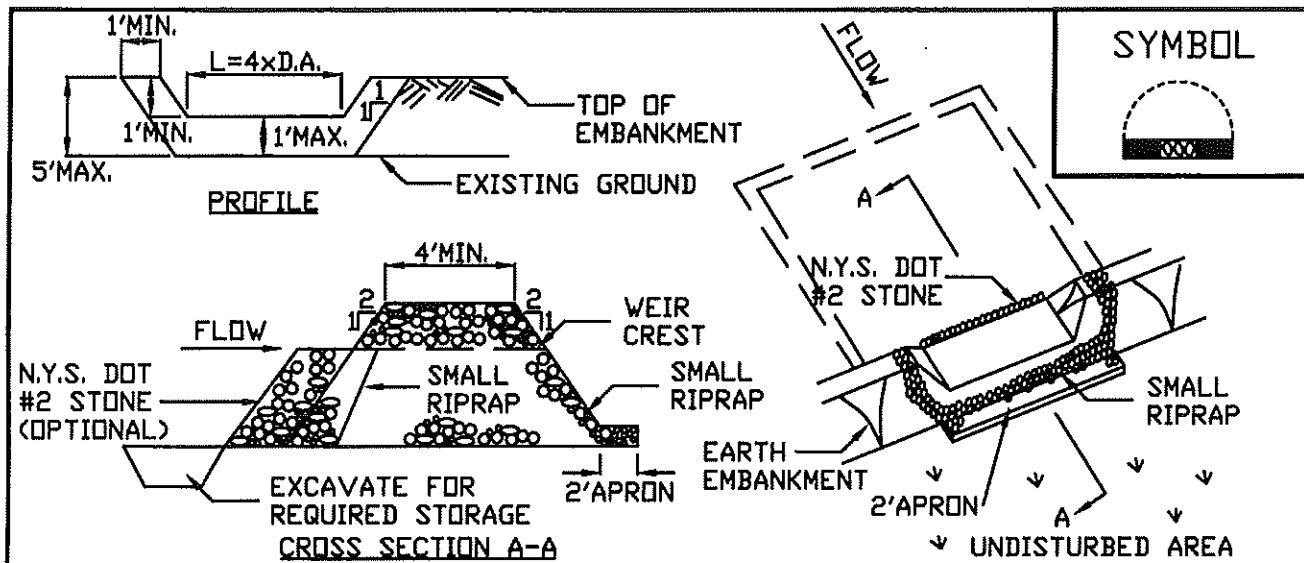

Figure 5A.19
Stone Outlet Sediment Trap: ST-IV



OPTION: A ONE FOOT LAYER OF N.Y.S. DOT #2 STONE MAY BE PLACED ON THE UPSTREAM SIDE OF THE RIPRAP IN PLACE OF THE EMBEDDED FILTER CLOTH.

CONSTRUCTION SPECIFICATIONS

1. AREA UNDER EMBANKMENT SHALL BE CLEARED, GRUBBED AND STRIPPED OF ANY VEGETATION AND ROOT MAT. THE POOL AREA SHALL BE CLEARED.
2. THE FILL MATERIAL FOR THE EMBANKMENT SHALL BE FREE OF ROOTS AND OTHER WOODY VEGETATION AS WELL AS OVER-SIZED STONES, ROCKS, ORGANIC MATERIAL OR OTHER OBJECTIONABLE MATERIAL. THE EMBANKMENT SHALL BE COMPACTED BY TRAVERSING WITH EQUIPMENT WHILE IT IS BEING CONSTRUCTED.
3. ALL CUT AND FILL SLOPES SHALL BE 2:1 OR FLATTER.
4. THE STONE USED IN THE OUTLET SHALL BE SMALL RIPRAP 4'-8' ALONG WITH A 1' THICKNESS OF 2" AGGREGATE PLACED ON THE UP-GRADE SIDE ON THE SMALL RIPRAP OR EMBEDDED FILTER CLOTH IN THE RIPRAP.
5. SEDIMENT SHALL BE REMOVED AND TRAP RESTORED TO ITS ORIGINAL DIMENSIONS WHEN THE SEDIMENT HAS ACCUMULATED TO 1/2 THE DESIGN DEPTH OF THE TRAP. IT SHALL BE PLACED ON SITE AND STABILIZED.
6. THE STRUCTURE SHALL BE INSPECTED AFTER EACH RAIN AND REPAIRS MADE AS NEEDED.
7. CONSTRUCTION OPERATIONS SHALL BE CARRIED OUT IN SUCH A MANNER THAT EROSION AND SEDIMENT ARE CONTROLLED.
8. THE STRUCTURE SHALL BE REMOVED AND THE AREA STABILIZED WHEN THE DRAINAGE AREA HAS BEEN PROPERLY STABILIZED.

MAXIMUM DRAINAGE AREA 5 ACRES

ADAPTED FROM DETAILS PROVIDED BY: USDA - NRCS,
NEW YORK STATE DEPARTMENT OF TRANSPORTATION,
NEW YORK STATE DEPARTMENT OF ENVIRONMENTAL CONSERVATION,
NEW YORK STATE SOIL & WATER CONSERVATION COMMITTEE

STONE OUTLET
SEDIMENT TRAP
ST-IV

Figure 5A.20(1)
Riprap Outlet Sediment Trap: ST-V

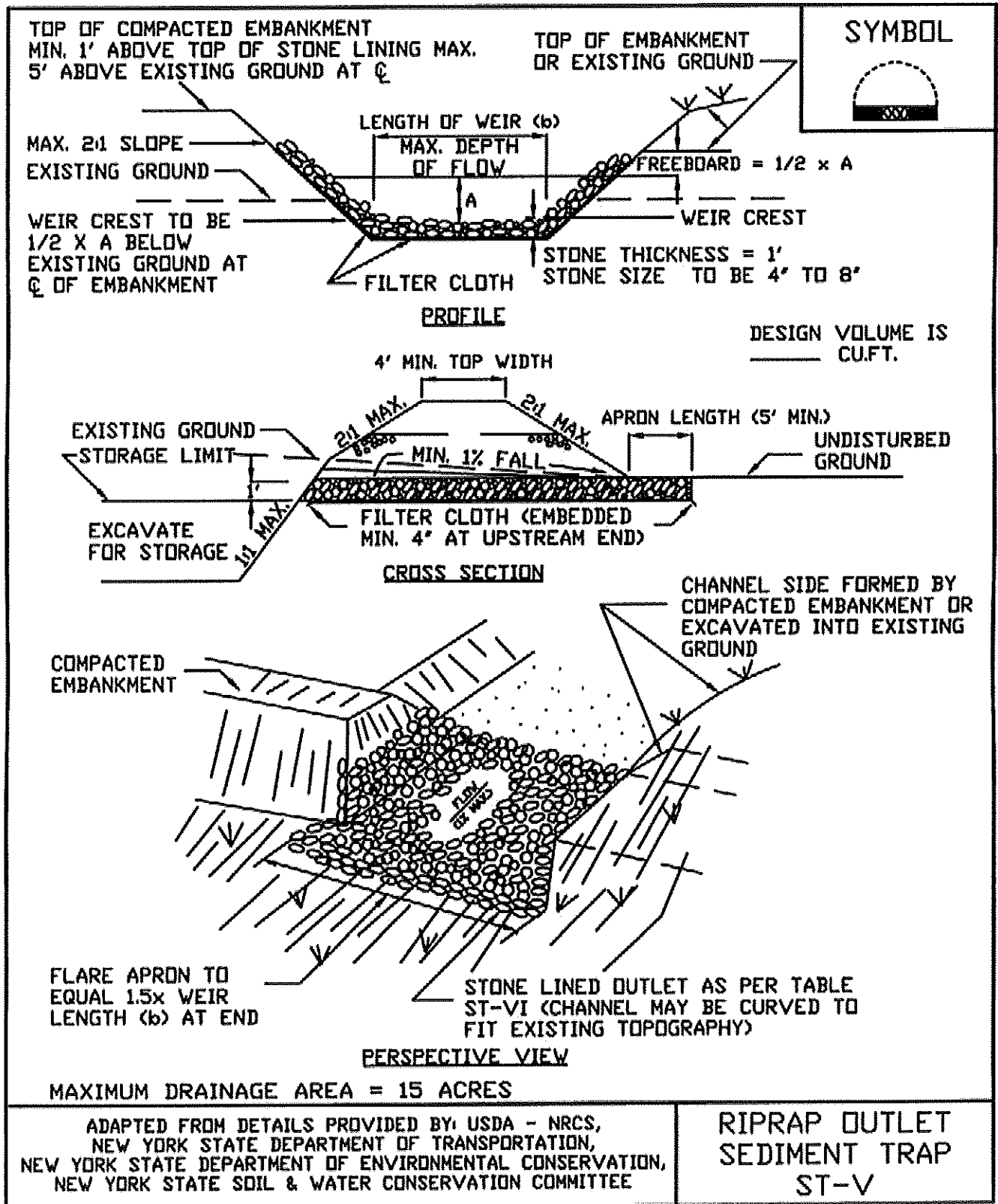

Figure 5A.202)

Riprap Outlet Sediment Trap: ST-V—Construction Specifications

SYMBOL



CONSTRUCTION SPECIFICATIONS

1. THE AREA UNDER EMBANKMENT SHALL BE CLEARED, GRUBBED AND STRIPPED OF ANY VEGETATION AND ROOT MAT. THE POOL AREA SHALL BE CLEARED.
2. THE FILL MATERIAL FOR THE EMBANKMENT SHALL BE FREE OF ROOTS OR OTHER WOODY VEGETATION AS WELL AS OVER-SIZED STONES, ROCKS, ORGANIC MATERIAL OR OTHER OBJECTIONABLE MATERIAL. THE EMBANKMENT SHALL BE COMPACTED BY TRAVERSING WITH EQUIPMENT WHILE IT IS BEING CONSTRUCTED. MAXIMUM HEIGHT OF EMBANKMENT SHALL BE FIVE (5) FEET, MEASURED AT CENTERLINE OF EMBANKMENT.
3. ALL FILL SLOPES SHALL BE 2:1 OR FLATTER, CUT SLOPES 1:1 OR FLATTER.
4. ELEVATION OF THE TOP OF ANY DIKE DIRECTING WATER INTO TRAP MUST EQUAL OR EXCEED THE HEIGHT OF EMBANKMENT.
5. STORAGE AREA PROVIDED SHALL BE FIGURED BY COMPUTING THE VOLUME AVAILABLE BEHIND THE OUTLET CHANNEL UP TO AN ELEVATION OF ONE (1) FOOT BELOW THE LEVEL WEIR CREST.
6. FILTER CLOTH SHALL BE PLACED OVER THE BOTTOM AND SIDES OF THE OUTLET CHANNEL PRIOR TO PLACEMENT OF STONE. SECTIONS OF FABRIC MUST OVERLAP AT LEAST ONE (1) FOOT WITH SECTION NEAREST THE ENTRANCE PLACED ON TOP. FABRIC SHALL BE EMBEDDED AT LEAST SIX (6) INCHES INTO EXISTING GROUND AT ENTRANCE OUTLET CHANNEL.
7. STONE USED IN THE OUTLET CHANNEL SHALL BE FOUR (4) TO EIGHT (8) INCH RIPRAP. TO PROVIDE A FILTERING EFFECT, A LAYER OF FILTER CLOTH SHALL BE EMBEDDED ONE (1) FOOT WITH SECTION NEAREST ENTRANCE PLACED ON TOP. FABRIC SHALL BE EMBEDDED AT LEAST SIX (6) INCHES INTO EXISTING GROUND AT ENTRANCE OF OUTLET CHANNEL.
8. SEDIMENT SHALL BE REMOVED AND TRAP RESTORED TO ITS ORIGINAL DIMENSIONS WHEN SEDIMENT HAS ACCUMULATED TO 1/2 THE DESIGN DEPTH OF THE TRAP. REMOVED SEDIMENT SHALL BE DEPOSITED IN A SUITABLE AREA AND IN SUCH A MANNER THAT IT WILL NOT ERODE.
9. THE STRUCTURE SHALL BE INSPECTED AFTER EACH RAIN AND REPAIRED AS NEEDED.
10. CONSTRUCTION OPERATIONS SHALL BE CARRIED OUT IN SUCH A MANNER THAT EROSION AND WATER POLLUTION ARE MINIMIZED.
11. THE STRUCTURE SHALL BE REMOVED AND THE AREA STABILIZED WHEN DRAINAGE AREA HAS BEEN PROPERLY STABILIZED.
12. DRAINAGE AREA FOR THIS PRACTICE IS LIMITED TO 15 ACRES OR LESS.

ADAPTED FROM DETAILS PROVIDED BY: USDA - NRCS,
NEW YORK STATE DEPARTMENT OF TRANSPORTATION,
NEW YORK STATE DEPARTMENT OF ENVIRONMENTAL CONSERVATION,
NEW YORK STATE SOIL & WATER CONSERVATION COMMITTEE

RIPRAP OUTLET
SEDIMENT TRAP
ST-V

Figure 5A.21
Optional Sediment Trap Dewatering Devices

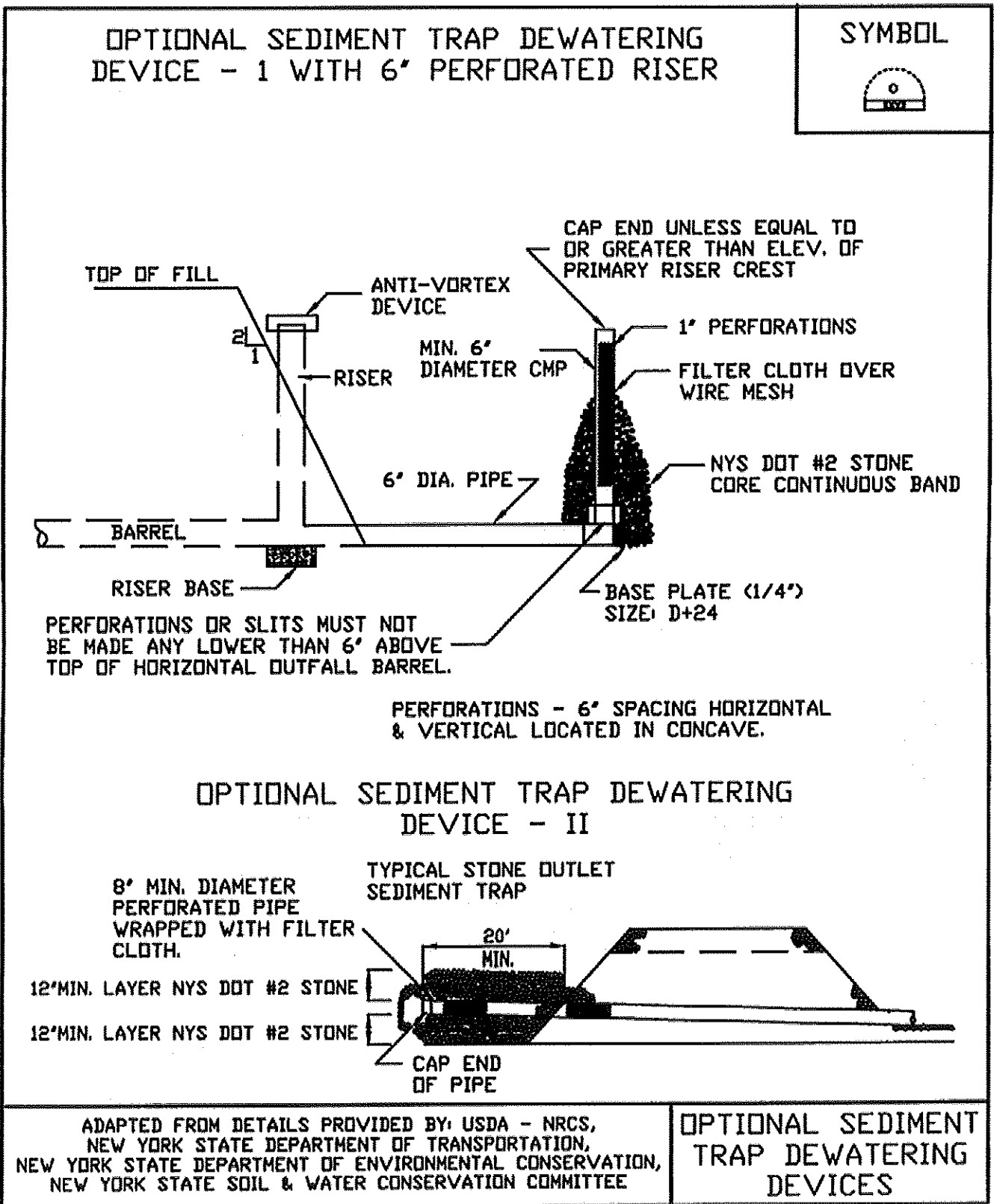

Figure 5A.31(1) Anti-Seep Collar Design

This procedure provides the anti-seep collar dimensions for only temporary sediment basins to increase the seepage length by 15% for various pipe slopes, embankment slopes and riser heights.

The first step in designing anti-seep collars is to determine the length of pipe within the saturated zone of the embankment. This can be done graphically or by the following equation, assuming that the upstream slope of the embankment intersects the invert of the pipe at its upstream end. (See embankment-invert intersection on the drawing below:

$$L_s = y (z + 4) \left[1 + \frac{\text{pipe slope}}{0.25 \text{-pipe slope}} \right]$$

Where: L_s = length of pipe in the saturated zone (ft.)

y = distance in feet from upstream invert of pipe to highest normal water level expected to occur during the life of the structure, usually the top of the riser.

z = slope of upstream embankment as a ratio of z ft. horizontal to one ft. vertical.

pipe slope = slope of pipe in feet per foot.

This procedure is based on the approximation of the phreatic line as shown in the drawing below:

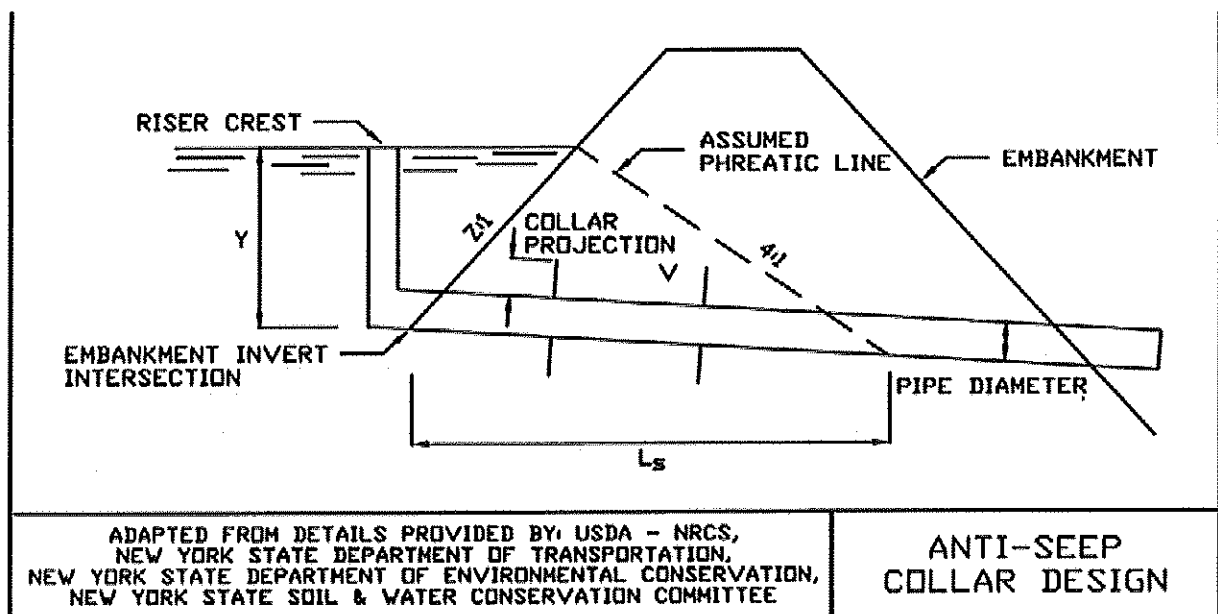
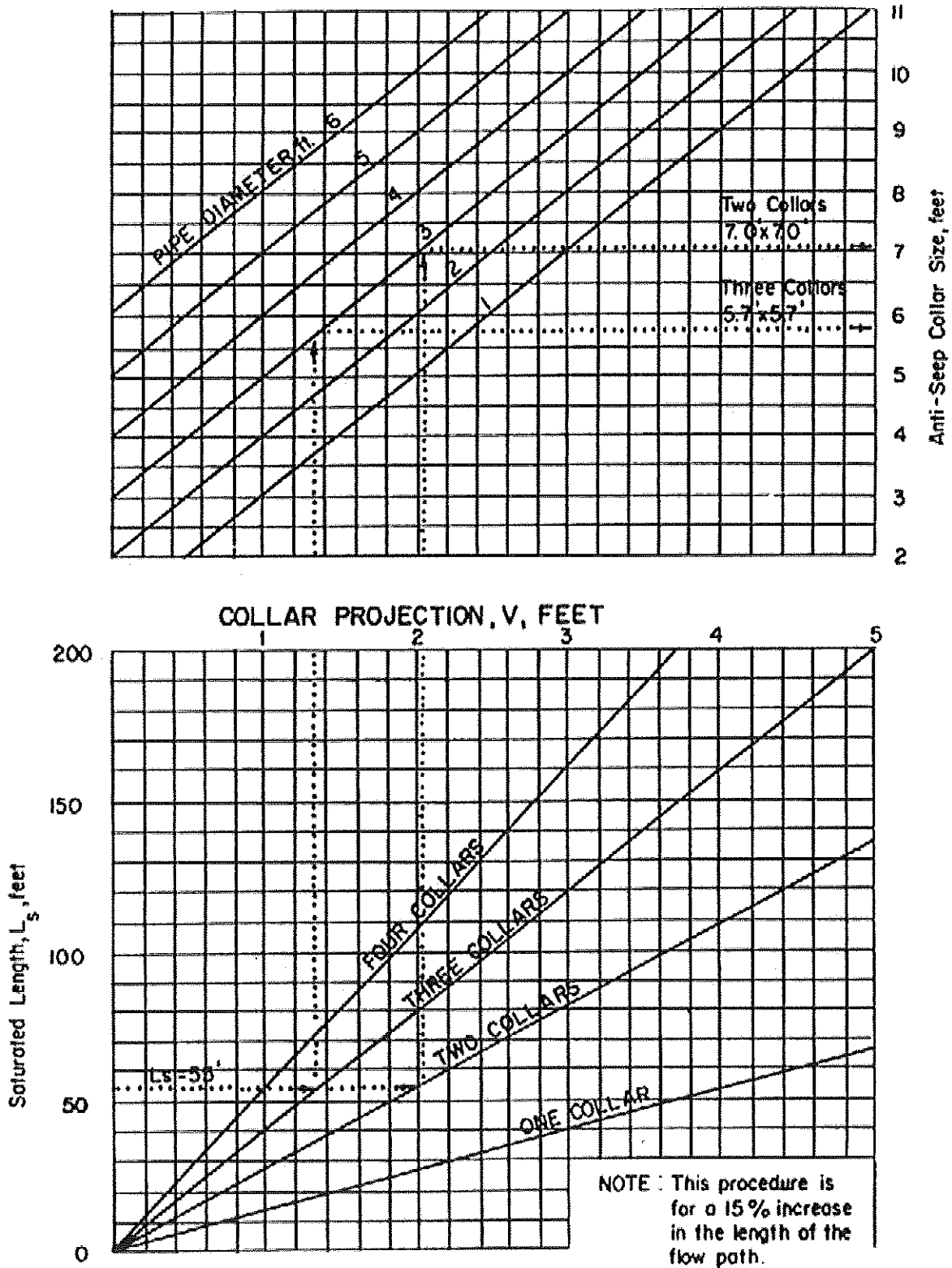
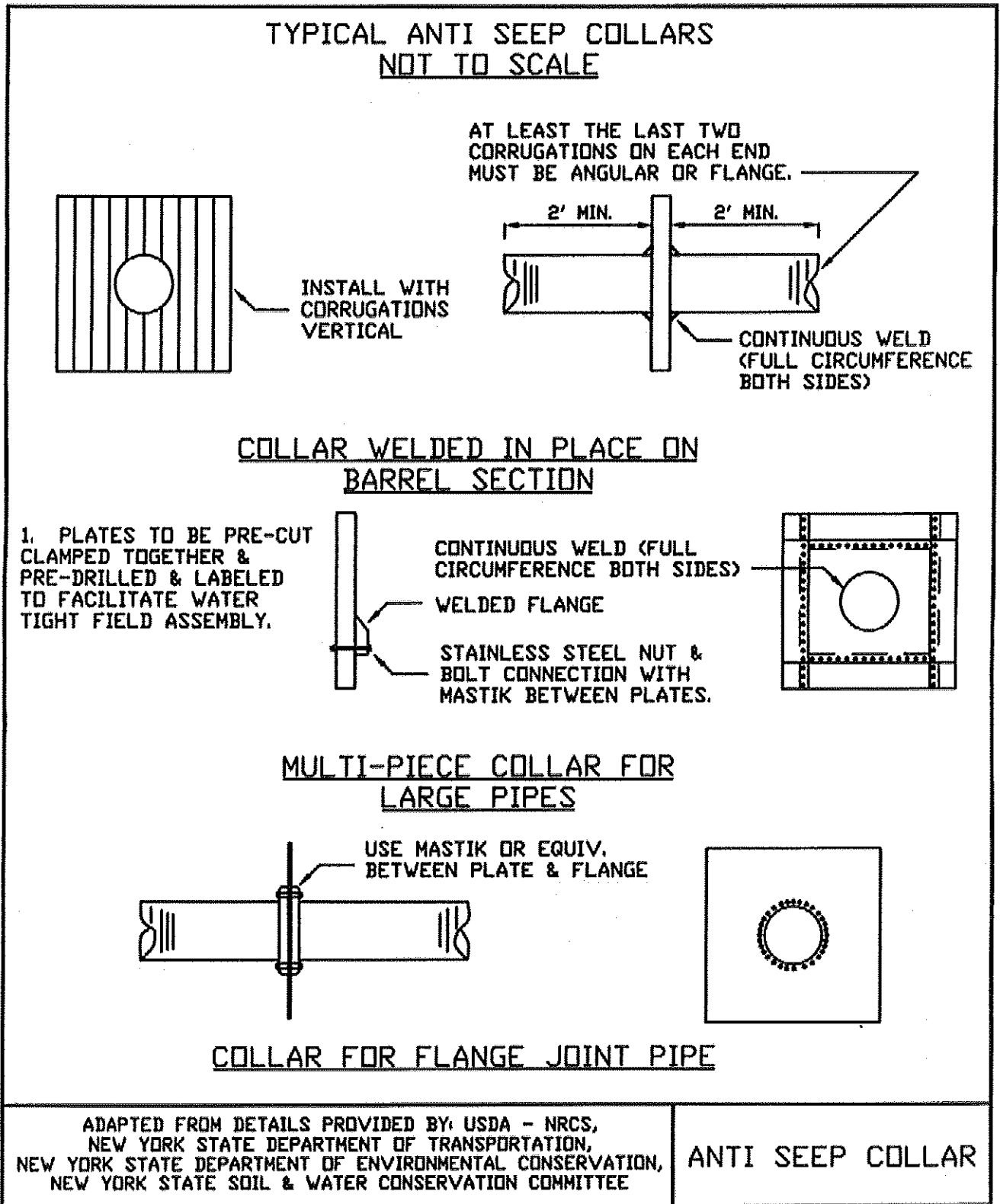

Figure 5A.31(2)
Anti-Seep Collar Design Charts (USDA - NRCS)



**Figure 5A.32
Anti-Seep Collar Design**



STANDARD AND SPECIFICATIONS FOR STABILIZED CONSTRUCTION ENTRANCE



Definition

A stabilized pad of aggregate underlain with geotextile located at any point where traffic will be entering or leaving a construction site to or from a public right-of-way, street, alley, sidewalk, or parking area.

Purpose

The purpose of stabilized construction entrance is to reduce or eliminate the tracking of sediment onto public rights-of-way or streets.

Conditions Where Practice Applies

A stabilized construction entrance shall be used at all points of construction ingress and egress.

Design Criteria

See Figure 5A.35 on page 5A.76 for details.

Aggregate Size: Use a matrix of 1-4 inch stone, or reclaimed or recycled concrete equivalent.

Thickness: Not less than six (6) inches.

Width: 12-foot minimum but not less than the full width of points where ingress or egress occurs. 24-foot minimum if there is only one access to the site.

Length: As required, but not less than 50 feet (except on a single residence lot where a 30 foot minimum would apply).

Geotextile: To be placed over the entire area to be covered with aggregate. Filter cloth will not be required on a single-family residence lot. Piping of surface water under entrance shall be provided as required. If piping is impossible, a mountable berm with 5:1 slopes will be permitted.

Criteria for Geotextile

The geotextile shall be woven or nonwoven fabric consisting only of continuous chain polymeric filaments or yarns of polyester. The fabric shall be inert to commonly encountered chemicals, hydro-carbons, mildew, rot resistant, and conform to the fabric properties as shown:

Fabric Properties ³	Light Duty ¹	Heavy Duty ²	Test Method
	Roads Grade Subgrade	Haul Roads Rough Graded	
Grab Tensile Strength (lbs)	200	220	ASTM D1682
Elongation at Failure (%)	50	60	ASTM D1682
Mullen Brust Strength (lbs)	190	430	ASTM D3786
Puncture Strength (lbs)	40	125	ASTM D751 modified
Equivalent Opening Size	40-80	40-80	US Std Sieve CW-02215
Aggregate Depth	6	10	--

¹Light Duty Road: Area sites that have been graded to subgrade and where most travel would be single axle vehicles and an occasional multi-axle truck. Acceptable materials are Trevira Spunbond 1115, Mirafi 100X, Typar 3401, or equivalent.

²Heavy Duty Road: Area sites with only rough grading, and where most travel would be multi-axle vehicles. Acceptable materials are Trevira Spunbond 1135, Mirafi 600X, or equivalent.

³Fabrics not meeting these specifications may be used only when design procedure and supporting documentation are supplied to determine aggregate depth and fabric strength.

Maintenance

The entrance shall be maintained in a condition which will prevent tracking of sediment onto public rights-of-way or streets. This may require periodic top dressing with additional aggregate. All sediment spilled, dropped, or washed onto public rights-of-way must be removed immediately.

When necessary, wheels must be cleaned to remove sediment prior to entrance onto public rights-of-way. When washing is required, it shall be done on an area stabilized with aggregate, which drains into an approved sediment-trapping device. All sediment shall be prevented from entering storm drains, ditches, or watercourses.

**Figure 5A.35
Stabilized Construction Entrance**

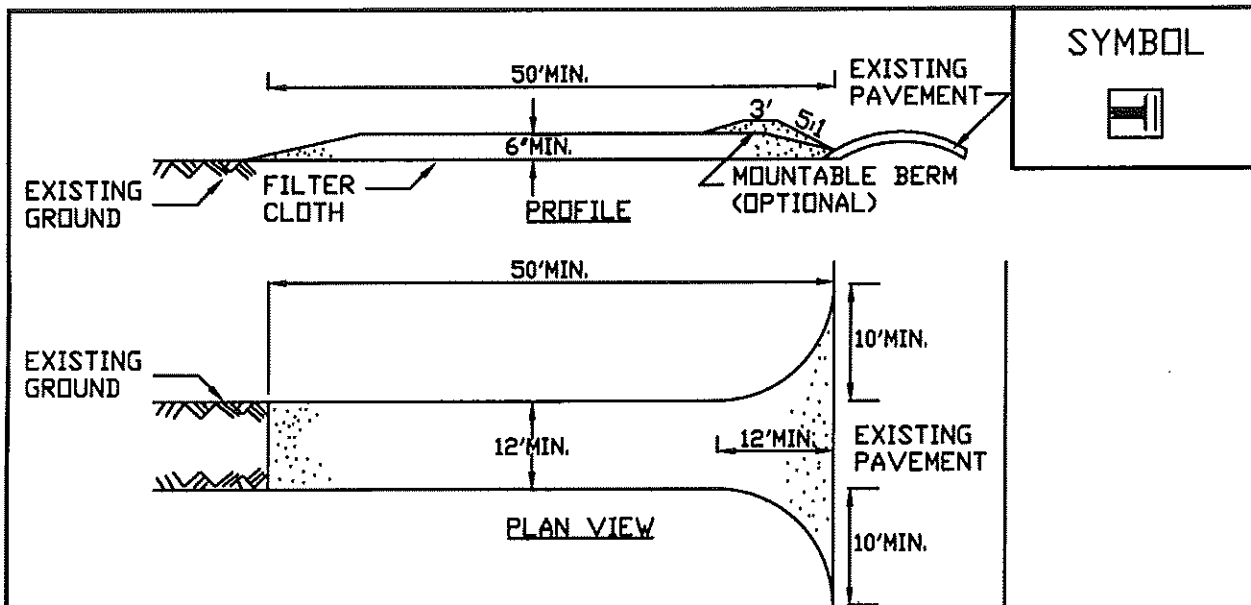

CONSTRUCTION SPECIFICATIONS

1. STONE SIZE - USE 1-4 INCH STONE, OR RECLAIMED OR RECYCLED CONCRETE EQUIVALENT.
2. LENGTH - NOT LESS THAN 50 FEET (EXCEPT ON A SINGLE RESIDENCE LOT WHERE A 30 FOOT MINIMUM LENGTH WOULD APPLY).
3. THICKNESS - NOT LESS THAN SIX (6) INCHES.
4. WIDTH - TWELVE (12) FOOT MINIMUM, BUT NOT LESS THAN THE FULL WIDTH AT POINTS WHERE INGRESS OR EGRESS OCCURS. TWENTY-FOUR (24) FOOT IF SINGLE ENTRANCE TO SITE.
5. GEOTEXTILE - WILL BE PLACED OVER THE ENTIRE AREA PRIOR TO PLACING OF STONE.
6. SURFACE WATER - ALL SURFACE WATER FLOWING OR DIVERTED TOWARD CONSTRUCTION ENTRANCES SHALL BE PIPED BENEATH THE ENTRANCE. IF PIPING IS IMPRACTICAL, A MOUNTABLE BERM WITH 5:1 SLOPES WILL BE PERMITTED.
7. MAINTENANCE - THE ENTRANCE SHALL BE MAINTAINED IN A CONDITION WHICH WILL PREVENT TRACKING OR FLOWING OF SEDIMENT ONTO PUBLIC RIGHTS-OF-WAY, ALL SEDIMENT SPILLED, DROPPED, WASHED OR TRACTED ONTO PUBLIC RIGHTS-OF-WAY MUST BE REMOVED IMMEDIATELY.
8. WHEN WASHING IS REQUIRED, IT SHALL BE DONE ON A AREA STABILIZED WITH STONE AND WHICH DRAINS INTO AN APPROVED SEDIMENT TRAPPING DEVICE.
9. PERIODIC INSPECTION AND NEEDED MAINTENANCE SHALL BE PROVIDED AFTER EACH RAIN.

ADAPTED FROM DETAILS PROVIDED BY: USDA - NRCS,
NEW YORK STATE DEPARTMENT OF TRANSPORTATION,
NEW YORK STATE DEPARTMENT OF ENVIRONMENTAL CONSERVATION,
NEW YORK STATE SOIL & WATER CONSERVATION COMMITTEE

**STABILIZED
CONSTRUCTION
ENTRANCE**

STANDARD AND SPECIFICATIONS FOR ROCK OUTLET PROTECTION



Definition

A section of rock protection placed at the outlet end of the culverts, conduits, or channels.

Purpose

The purpose of the rock outlet protection is to reduce the depth, velocity, and energy of water, such that the flow will not erode the receiving downstream reach.

Scope

This standard applies to the planning, design, and construction of rock riprap and gabions for protection of downstream areas. It does not apply to rock lining of channels or streams.

Conditions Where Practice Applies

This practice applies where discharge velocities and energies at the outlets of culverts, conduits, or channels are sufficient to erode the next downstream reach. This applies to:

1. Culvert outlets of all types.
2. Pipe conduits from all sediment basins, dry storm water ponds, and permanent type ponds.
3. New channels constructed as outlets for culverts and conduits.

Design Criteria

The design of rock outlet protection depends entirely on the location. Pipe outlet at the top of cuts or on slopes steeper than 10 percent, cannot be protected by rock aprons or riprap sections due to re-concentration of flows and high velocities encountered after the flow leaves the apron.

Many counties and state agencies have regulations and design procedures already established for dimensions, type and size of materials, and locations where outlet protection is required. Where these requirements exist, they shall be followed.

Tailwater Depth

The depth of tailwater immediately below the pipe outlet must be determined for the design capacity of the pipe. If the tailwater depth is less than half the diameter of the outlet pipe, and the receiving stream is wide enough to accept divergence of the flow, it shall be classified as a Minimum Tailwater Condition; see Figure 5B.12 on page 5B.25 as an example. If the tailwater depth is greater than half the pipe diameter and the receiving stream will continue to confine the flow, it shall be classified as a Maximum Tailwater Condition; see Figure 5B.13 on page 5B.26 as an example. Pipes which outlet onto flat areas with no defined channel may be assumed to have a Minimum Tailwater Condition; see Figure 5B.12 on page 5B.25 as an example.

Apron Size

The apron length and width shall be determined from the curves according to the tailwater conditions:

- Minimum Tailwater – Use Figure 5B.12 on page 5B.25
- Maximum Tailwater – Use Figure 5B.13 on page 5B.26

If the pipe discharges directly into a well defined channel, the apron shall extend across the channel bottom and up the channel banks to an elevation one foot above the maximum tailwater depth or to the top of the bank, whichever is less.

The upstream end of the apron, adjacent to the pipe, shall have a width two (2) times the diameter of the outlet pipe, or conform to pipe end section if used.

Bottom Grade

The outlet protection apron shall be constructed with no slope along its length. There shall be no overfall at the end of the apron. The elevation of the downstream end of the apron shall be equal to the elevation of the receiving channel or adjacent ground.

Alignment

The outlet protection apron shall be located so that there are no bends in the horizontal alignment.

Materials

The outlet protection may be done using rock riprap, grouted riprap, or gabions.

Riprap shall be composed of a well-graded mixture of stone size so that 50 percent of the pieces, by weight, shall be larger than the d_{50} size determined by using the charts. A well-graded mixture, as used herein, is defined as a mixture composed primarily of larger stone sizes, but with a sufficient mixture of other sizes to fill the smaller voids between the stones. The diameter of the largest stone size in such a mixture shall be 1.5 times the d_{50} size.

Thickness

The minimum thickness of the riprap layer shall be 1.5 times the maximum stone diameter for d_{50} of 15 inches or less; and 1.2 times the maximum stone size for d_{50} greater than 15 inches. The following chart lists some examples:

D_{50} (inches)	d_{max} (inches)	Minimum Blanket Thickness (inches)
4	6	9
6	9	14
9	14	20
12	18	27
15	22	32
18	27	32
21	32	38
24	36	43

Stone Quality

Stone for riprap shall consist of field stone or rough unhewn quarry stone. The stone shall be hard and angular and of a quality that will not disintegrate on exposure to water or weathering. The specific gravity of the individual stones shall be at least 2.5.

Recycled concrete equivalent may be used provided it has a

density of at least 150 pounds per cubic foot, and does not have any exposed steel or reinforcing bars.

Filter

A filter is a layer of material placed between the riprap and the underlying soil surface to prevent soil movement into and through the riprap. Riprap shall have a filter placed under it in all cases.

A filter can be of two general forms: a gravel layer or a plastic filter cloth. The plastic filter cloth can be woven or non-woven monofilament yarns, and shall meet these base requirements: thickness 20-60 mils, grab strength 90-120 lbs; and shall conform to ASTM D-1777 and ASTM D-1682.

Gravel filter blanket, when used, shall be designed by comparing particle sizes of the overlying material and the base material. Design criteria are available in Standard and Specification for Riprap Slope Protection on page 5B.57.

Gabions

Gabions shall be made of hexagonal triple twist mesh with heavily galvanized steel wire. The maximum linear dimension of the mesh opening shall not exceed 4 ½ inches and the area of the mesh opening shall not exceed 10 square inches.

Gabions shall be fabricated in such a manner that the sides, ends, and lid can be assembled at the construction site into a rectangular basket of the specified sizes. Gabions shall be of single unit construction and shall be installed according to manufacturers recommendations.

The area on which the gabion is to be installed shall be graded as shown on the drawings. Foundation conditions shall be the same as for placing rock riprap, and filter cloth shall be placed under all gabions. Where necessary, key, or tie, the structure into the bank to prevent undermining of the main gabion structure.

Maintenance

Once a riprap outlet has been installed, the maintenance needs are very low. It should be inspected after high flows for evidence of scour beneath the riprap or for dislodged stones. Repairs should be made immediately.

Design Procedure

1. Investigate the downstream channel to assure that nonerosive velocities can be maintained.
2. Determine the tailwater condition at the outlet to establish which curve to use.
3. Enter the appropriate chart with the design discharge to

determine the riprap size and apron length required. It is noted that references to pipe diameters in the charts are based on full flow. For other than full pipe flow, the parameters of depth of flow and velocity must be used to adjust the design discharges.

- Calculate apron width at the downstream end if a flare section is to be employed.

Examples

Example 1: Pipe Flow (full) with discharge to unconfined section.

Given: A circular conduit flowing full.

$Q = 280$ cfs, diam. = 66 in., tailwater (surface) is 2 ft. above pipe invert (minimum tailwater condition).

Find: Read $d_{50} = 1.2$ and apron length (L_a) = 38 ft.

Apron width = diam. + $L_a = 5.5 + 38 = 43.5$ ft.

Use: $d_{50} = 15"$, $d_{max} = 22"$, blanket thickness = 32"

Example 2: Box Flow (partial) with high tailwater

Given: A box conduit discharging under partial flow conditions. A concrete box 5.5 ft. x 10 ft. flowing 5.0 ft. deep,

$Q = 600$ cfs and tailwater surface is 5 ft. above invert (max. tailwater condition).

Since this is not full pipe and does not directly fit the nomograph assumptions of Figure 7B.13 substitute depth as the diameter, to find a discharge equal to full pipe flow for that diameter, in this case 60 inches.

Since, $Q = AV$ and $A = \frac{\pi D^2}{4}$

First, compute velocity:

$V = (Q/A) = (600/(5) (10)) = 12$ fps

Then substituting:

$$Q = \frac{\pi D^2}{4} \times V = \frac{3.14 (5 \text{ ft})^2}{4} \times 12 \text{ fps} = 236 \text{ cfs}$$

At the intersection of the curve $d = 60$ in. and $Q = 236$ cfs, read $d_{50} = 0.4$ ft.

Then reading the $d = 60$ in. curve, read apron length (L_a) = 40 ft.

Apron width, $W = \text{conduit width} + (6.4)(L_a) = 10 + (0.4)(40) = 26$ ft.

Example 3: Open Channel Flow with Discharge to Unconfined Section

Given: A trapezoidal concrete channel 5 ft. wide with 2:1 side slopes is flowing 2 ft. deep, $Q = 180$ cfs (velocity = 10 fps) and the tailwater surface downstream is 0.8 ft. (minimum tailwater condition).

Find: Using similar principles as Example 2, compute equivalent discharge for a 2 foot, using depth as a diameter, circular pipe flowing full at 10 feet per second.

Velocity:

$$Q = \frac{\pi (2 \text{ ft})^2}{4} \times 10 \text{ fps} = 31.4 \text{ cfs}$$

At intersection of the curve, $d = 24$ in. and $Q = 32$ cfs, read $d_{50} = 0.6$ ft.

Then reading the $d = 24$ in. curve, read apron length (L_a) = 20 ft.

Apron width, $W = \text{bottom width of channel} + L_a = 5 + 20 = 25$ ft.

Example 4: Pipe flow (partial) with discharge to a confined section

Given: A 48 in. pipe is discharging with a depth of 3 ft. $Q = 100$ cfs, and discharge velocity of 10 fps (established from partial flow analysis) to a confined trapezoidal channel with a 2 ft. bottom, 2:1 side slopes, $n = .04$, and grade of 0.6%.

Calculation of the downstream channel (by Manning's Equation) indicates a normal depth of 3.1 ft. and normal velocity of 3.9 fps.

Since the receiving channel is confined, the maximum tailwater condition controls.

Find: discharge using previous principles:

$$Q = \frac{\pi (3 \text{ ft})^2}{4} \times 10 \text{ fps} = 71 \text{ cfs}$$

At the intersection of $d = 36$ in. and $Q = 71$ cfs, read $d_{50} = 0.3$ ft.

Reading the $d = 36"$ curve, read apron length (L_a) = 30 ft.

Since the maximum flow depth in this reach is 3.1 ft., that is the minimum depth of riprap to be maintained for the entire length.

Construction Specifications

1. The subgrade for the filter, riprap, or gabion shall be prepared to the required lines and grades. Any fill required in the subgrade shall be compacted to a density of approximately that of the surrounding undisturbed material.
2. The rock or gravel shall conform to the specified grading limits when installed respectively in the riprap or filter.
3. Filter cloth shall be protected from punching, cutting, or tearing. Any damage other than an occasional small hole shall be repaired by placing another piece of cloth over the damaged part or by completely replacing the cloth. All overlaps, whether for repairs or for joining two pieces of cloth shall be a minimum of one foot.
4. Stone for the riprap or gabion outlets may be placed by equipment. Both shall each be constructed to the full course thickness in one operation and in such a manner as to avoid displacement of underlying materials. The stone for riprap or gabion outlets shall be delivered and placed in a manner that will ensure that it is reasonably homogenous with the smaller stones and spalls filling the voids between the larger stones. Riprap shall be placed in a manner to prevent damage to the filter blanket or filter cloth. Hand placement will be required to the extent necessary to prevent damage to the permanent works.

Figure 5B.12
Outlet Protection Design—Minimum Tailwater Condition
(Design of Outlet Protection from a Round Pipe Flowing Full,
Minimum Tailwater Condition: $T_w < 0.5D_o$) (USDA - NRCS)

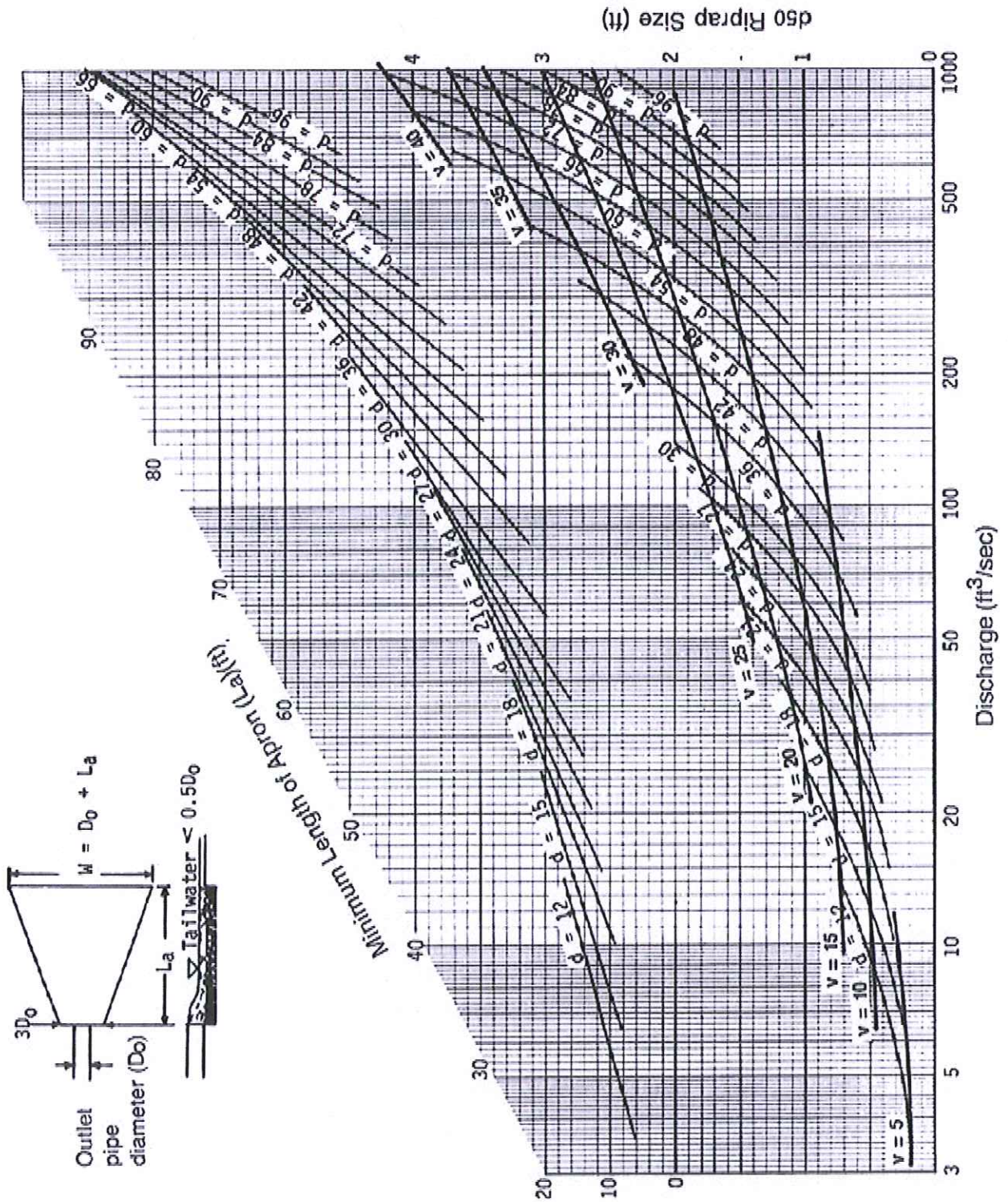
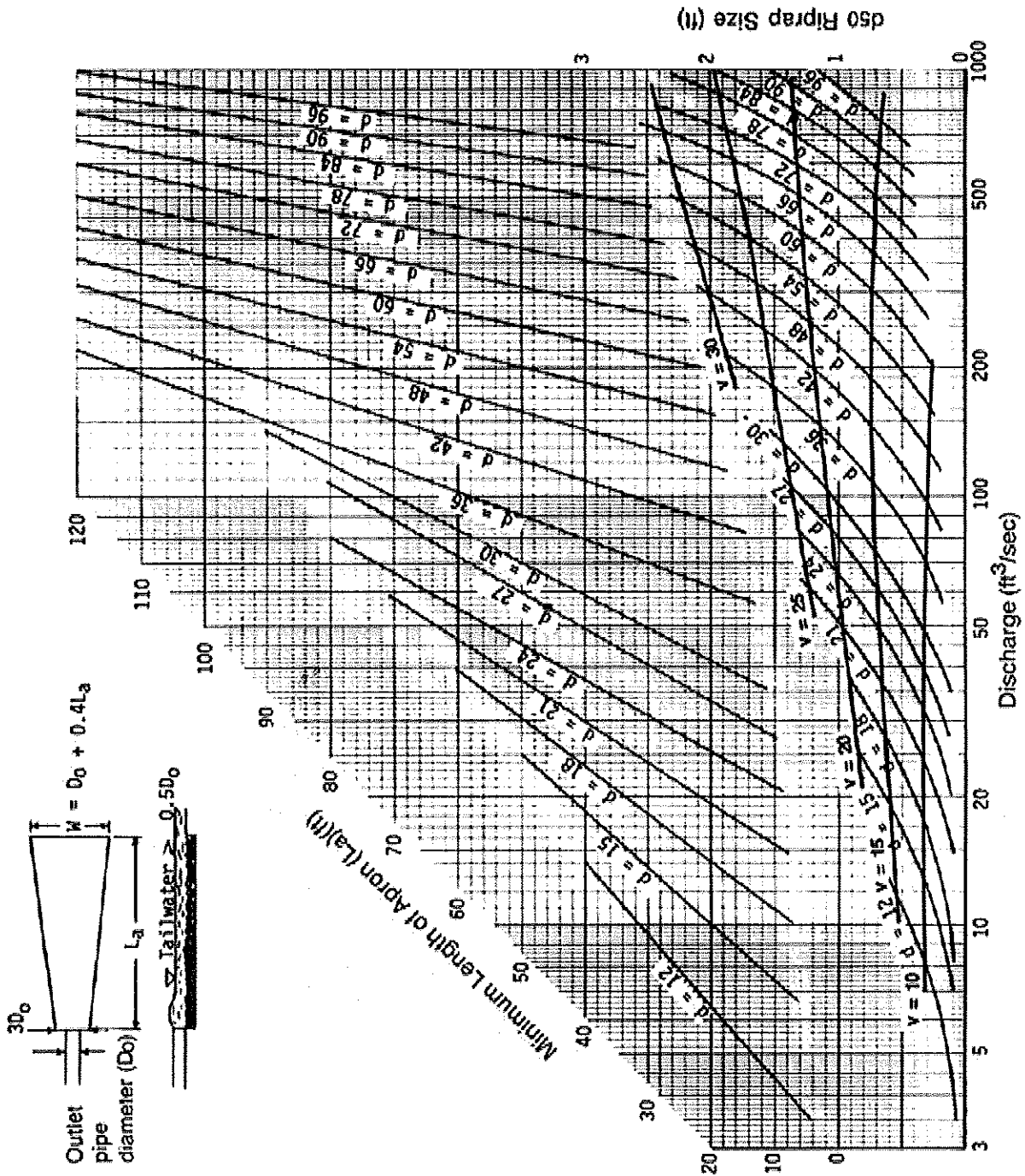

Figure 5B.13
Outlet Protection Design—Maximum Tailwater Condition
(Design of Outlet Protection from a Round Pipe Flowing Full,
Maximum Tailwater Condition: $T_w \geq 0.5D_o$) (USDA - NRCS)



**Figure 5B.14
Riprap Outlet Protection Detail (1)**

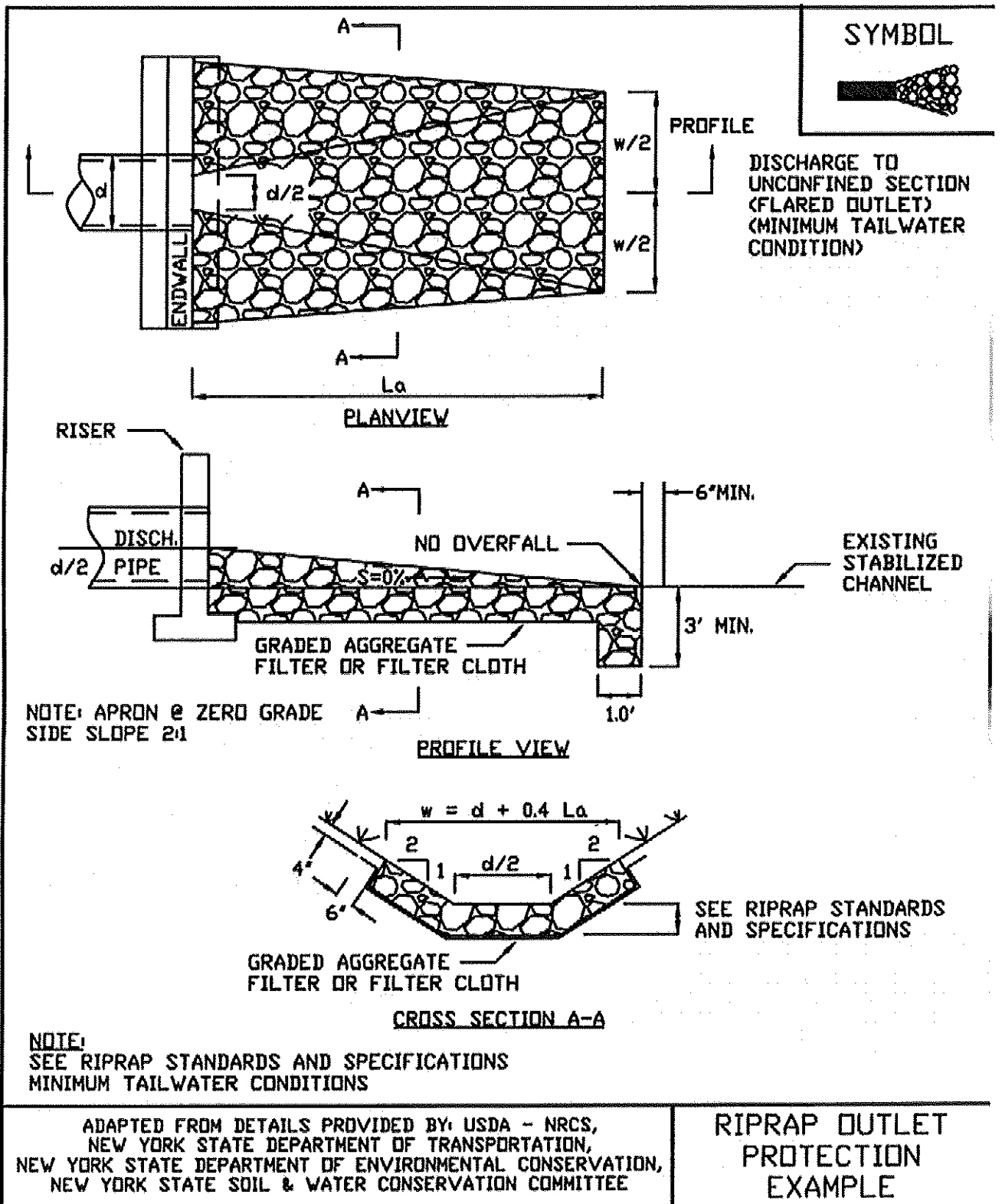
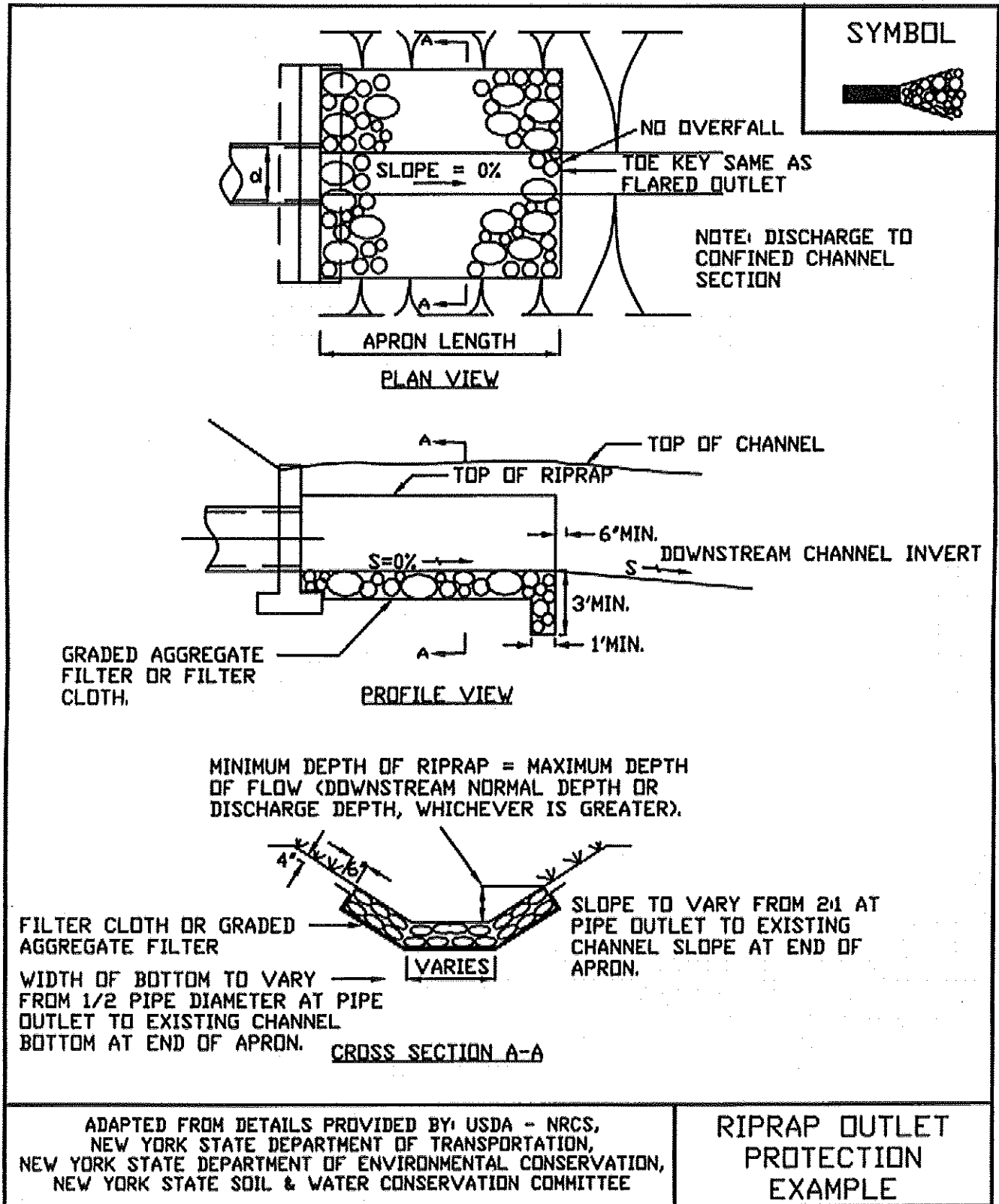
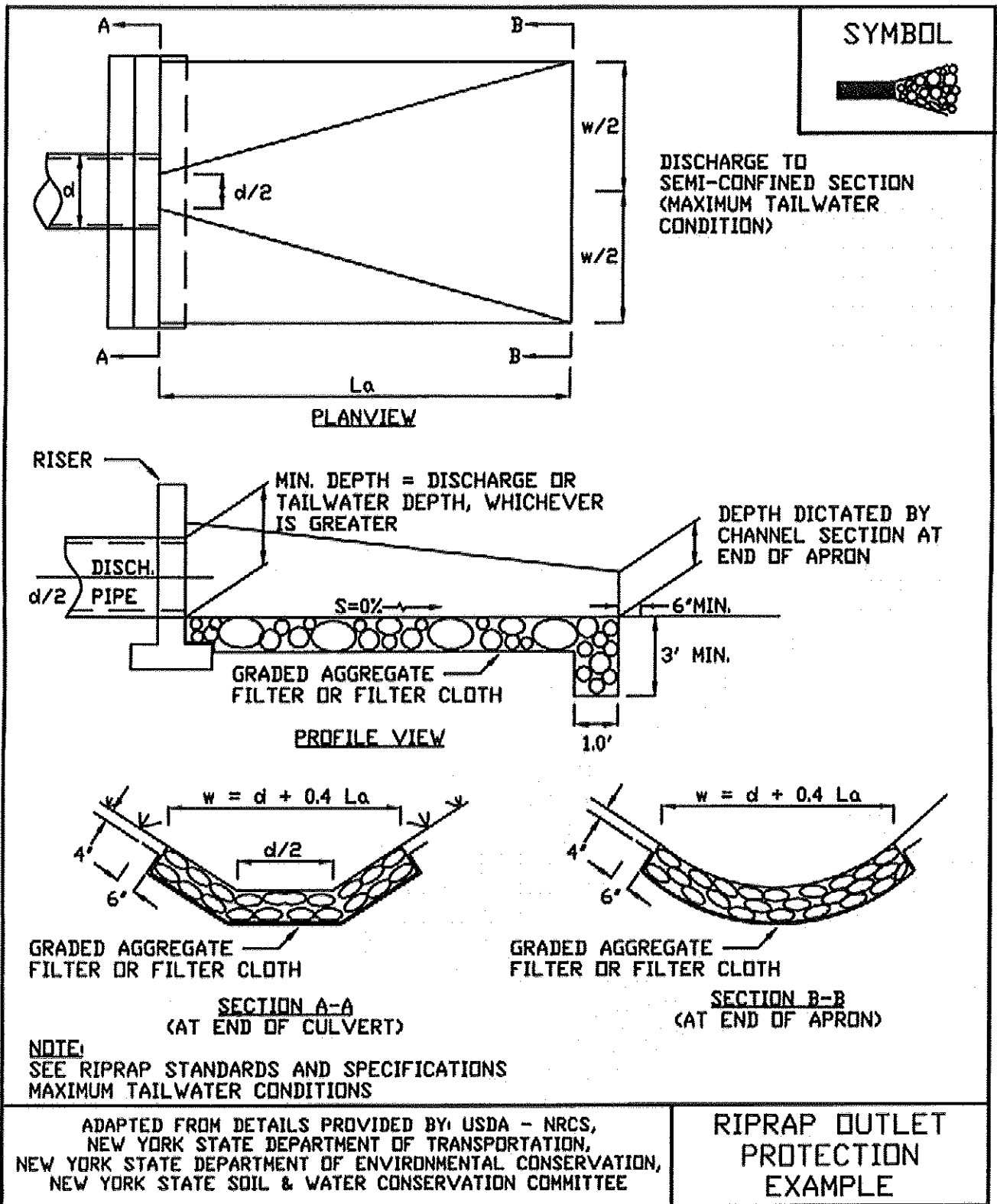

Figure 5B.15
Riprap Outlet Protection Detail (2)



**Figure 5B.16
Riprap Outlet Protection Detail (3)**



Appendix C: Construction Standards and Specifications**C.1 Pond Construction Standards/Specifications**

These specifications are generally appropriate to all earthen ponds, and are adapted from NRCS Pond Code 378. This document is available at <http://www.dec.state.ny.us/website/dow/toolbox/tools.html>. Practitioners should always consult the New York State Department of Environmental Conservation – Dam Safety Division for the most recent guidance. All references to ASTM and AASHTO specifications apply to the most recent version.

C.3 Construction Specifications for Bioretention, Sand Filters and Open Channels**Sand Filter Specifications****Material Specifications for Sand Filters**

The allowable materials for sand filter construction are detailed in Table 1.

Sand Filter Testing Specifications

Underground sand filters, facilities within sensitive groundwater aquifers, and filters designed to serve urban hot spots are to be tested for water tightness prior to placement of filter layers. Entrances and exits should be plugged and the system completely filled with water to demonstrate water tightness.

All overflow weirs, multiple orifices and flow distribution slots to be field-tested as to verify adequate distribution of flows.

Sand Filter Construction Specifications

Provide sufficient maintenance access; 12-foot-wide road with legally recorded easement. Vegetated access slopes to be a maximum of 10%; gravel slopes to 15%; paved slopes to 25%.

Absolutely no runoff is to enter the filter until all contributing drainage areas have been stabilized.

Surface of filter bed to be *completely level*.

All sand filters should be clearly delineated with signs so that they may be located when maintenance is due.

Surface sand filters shall be planted with appropriate grasses as specified in your local NRCS Standards and Specifications guidance.

Pocket sand filters (and residential bioretention facilities treating areas larger than an acre) shall be sized with an ornamental stone window covering approximately 10% of the filter area. This surface shall be 2" to 5" size stone on top of a pea gravel layer (3/4 inch stone) approximately 4 to 6" of pea gravel.

Specifications for Bioretention

Material Specifications

The allowable materials to be used in bioretention area are detailed in Table G.2.

Planting Soil

The soil shall be a uniform mix, free of stones, stumps, roots or other similar objects larger than two inches. No other materials or substances shall be mixed or dumped within the bioretention area that may be harmful to plant growth, or prove a hindrance to the planting or maintenance operations. The planting soil shall be free of noxious weeds.

The planting soil shall be tested and shall meet the following criteria:

pH range	5.2 - 7.0
organic matter	1.5 - 4%
magnesium	35 lb./ac
phosphorus P ₂ O ₅	75 lb./ac
potassium K ₂ O	85 lb./ac
soluble salts	not to exceed 500 ppm

All bioretention areas shall have a minimum of one test. Each test shall consist of both the standard soil test for pH, phosphorus, and potassium and additional tests of organic matter, and soluble salts. A textural analysis is required from the site stockpiled topsoil. If topsoil is imported, then a texture analysis shall be performed for each location where the top soil was excavated.

Since different labs calibrate their testing equipment differently, all testing results shall come from the same testing facility.

Should the pH fall out of the acceptable range, it may be modified (higher) with lime or (lower) with iron sulfate plus sulfur.

Compaction

It is very important to minimize compaction of both the base of the bioretention area and the required backfill. When possible, use excavation hoes to remove original soil. If bioretention areas are excavated using a loader, the contractor should use wide track or marsh track equipment, or light equipment with turf type tires. Use of equipment with narrow tracks or narrow tires, rubber tires with large lugs, or high pressure tires will cause excessive compaction resulting in reduced infiltration rates and storage volumes and is not acceptable. Compaction will significantly contribute to design failure.

Compaction can be alleviated at the base of the bioretention facility by using a primary tilling operation such as a chisel plow, ripper, or subsoiler. These tilling operations are to refracture the soil profile through the 12 inch compaction zone. Substitute methods must be approved by the engineer. Rototillers typically do not till deep enough to reduce the effects of compaction from heavy equipment.

Rototill 2 to 3 inches of sand into the base of the bioretention facility before back filling the required sand layer. Pump any ponded water before preparing (rototilling) base.

When back filling the topsoil over the sand layer, first place 3 to 4 inches of topsoil over the sand, then rototill the sand/topsoil to create a gradation zone. Backfill the remainder of the topsoil to final grade.

When back filling the bioretention facility, place soil in lifts 12" or greater. Do not use heavy equipment within the bioretention basin. Heavy equipment can be used around the perimeter of the basin to supply soils and sand. Grade bioretention materials by hand or with light equipment such as a compact loader or a dozer/loader with marsh tracks.

Plant Installation

Mulch around individual plants only. Shredded hardwood mulch is the only accepted mulch. Pine mulch and wood chips will float and move to the perimeter of the bioretention area during a storm event and are not acceptable. Shredded mulch must be well aged (6 to 12 months) for acceptance.

The plant root ball should be planted so 1/8th of the ball is above final grade surface.

Root stock of the plant material shall be kept moist during transport and on-site storage. The diameter of the planting pit shall be at least six inches larger than the diameter of the planting ball. Set and maintain the plant straight during the entire planting process. Thoroughly water ground bed cover after installation.

Trees shall be braced using 2" X 2" stakes only as necessary and for the first growing season only. Stakes are to be equally spaced on the outside of the tree ball.

Grasses and legume seed shall be tilled into the soil to a depth of at least one inch. Grass and legume plugs shall be planted following the non-grass ground cover planting specifications.

The topsoil specifications provide enough organic material to adequately supply nutrients from natural cycling. The primary function of the bioretention structure is to improve water quality. Adding fertilizers defeats, or at a minimum, impedes this goal. Only add fertilizer if wood chips or mulch is used to amend the soil. Rototill urea fertilizer at a rate of 2 pounds per 1000 square feet.

Underdrains

Under drains to be placed on a 3'-0" wide section of filter cloth. Pipe is placed next, followed by the gravel bedding. The ends of under drain pipes not terminating in an observation well shall be capped.

The main collector pipe for underdrain systems shall be constructed at a minimum slope of 0.5%. Observation wells and/or clean-out pipes must be provided (one minimum per every 1000 square feet of surface area).

Miscellaneous

The bioretention facility may not be constructed until all contributing drainage area has been stabilized.

Table C.2 Materials Specifications for Bioretention

Parameter	Specification	Size	Notes
Plantings	see your local NRCS Standards and Specifications guidance.	n/a	plantings are site-specific
Planting Soil [4= deep]	sand 35 - 60% silt 30 - 55% clay 10 - 25%	n/a	USDA soil types loamy sand, sandy loam or loam
Mulch	shredded hardwood		aged 6 months, minimum
pea gravel diaphragm and curtain drain	pea gravel: ASTM D 448 ornamental stone: washed cobbles	pea gravel: No. 6 stone: 2" to 5"	
Geotextile	Class "C" apparent opening size (ASTM-D-4751) grab tensile strength (ASTM-D-4632) burst strength (ASTM-D-4833)	n/a	for use as necessary beneath underdrains only
underdrain gravel	AASHTO M-43, No. 67.	0.25" to 0.75"	
underdrain piping	ASTM D 1785 or AASHTO M-278	6" rigid schedule 40 PVC	3/8" perf. @ 6" on center, 4 holes per row; minimum of 3" of gravel over pipes; not necessary underneath pipes
poured in place concrete (if required)	See local DOT Standards and Specs.; f=c = 3500 psi. @ 28 days, normal weight, air-entrained, re-inforcing to meet ASTM 615-60	n/a	on-site testing of poured-in-place concrete required: 28 day strength and slump test; all concrete design (cast-in-place or pre-cast) <i>not using previously approved State or local standards</i> requires design drawings sealed and approved by a licensed professional structural engineer.
sand [1= deep]	AASHTO M-6 or ASTM C-33	0.02" to 0.04"	Sand substitutions such as Diabase and Graystone #10 are not acceptable. No calcium carbonated or dolomitic sand substitutions are acceptable. No "rock dust" can be used for sand.

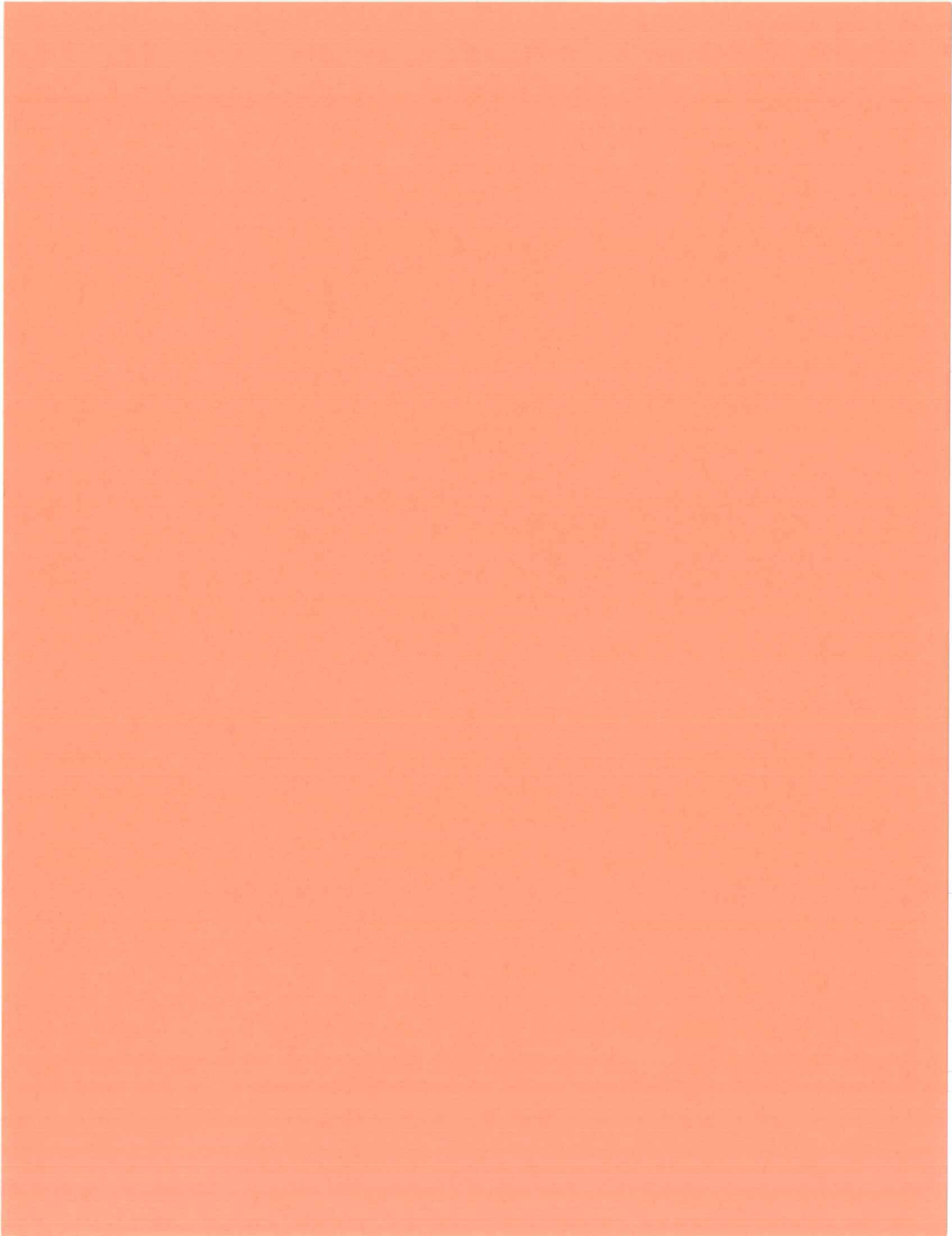

APPENDIX F

STANDARD CONSTRUCTION INSPECTION FORMS
STANDARD MAINTENANCE INSPECTION FORMS

Stormwater/Wetland Pond Construction Inspection Checklist

Project:
 Location:
 Site Status:

Date:

Time:

Inspector:

CONSTRUCTION SEQUENCE	SATISFACTORY/ UNSATISFACTORY	COMMENTS
Pre-Construction/Materials and Equipment		
Pre-construction meeting		
Pipe and appurtenances on-site prior to construction and dimensions checked		
1. Material (including protective coating, if specified)		
2. Diameter		
3. Dimensions of metal riser or pre-cast concrete outlet structure		
4. Required dimensions between water control structures (orifices, weirs, etc.) are in accordance with approved plans		
5. Barrel stub for prefabricated pipe structures at proper angle for design barrel slope		
6. Number and dimensions of prefabricated anti-seep collars		
7. Watertight connectors and gaskets		
8. Outlet drain valve		
Project benchmark near pond site		
Equipment for temporary de-watering		

CONSTRUCTION SEQUENCE	SATISFACTORY/ UNSATISFACTORY	COMMENTS
2. Subgrade Preparation		
Area beneath embankment stripped of all vegetation, topsoil, and organic matter		
3. Pipe Spillway Installation		
Method of installation detailed on plans		
A. Bed preparation		
Installation trench excavated with specified side slopes		
Stable, uniform, dry subgrade of relatively impervious material (If subgrade is wet, contractor shall have defined steps before proceeding with installation)		
Invert at proper elevation and grade		
B. Pipe placement		
Metal / plastic pipe		
1. Watertight connectors and gaskets properly installed		
2. Anti-seep collars properly spaced and having watertight connections to pipe		
3. Backfill placed and tamped by hand under "haunches" of pipe		
4. Remaining backfill placed in max. 8 inch lifts using small power tamping equipment until 2 feet cover over pipe is reached		

CONSTRUCTION SEQUENCE	SATISFACTORY/ UNSATISFACTORY	COMMENTS
3. Pipe Spillway Installation		
Concrete pipe		
1. Pipe set on blocks or concrete slab for pouring of low cradle		
2. Pipe installed with rubber gasket joints with no spalling in gasket interface area		
3. Excavation for lower half of anti-seep collar(s) with reinforcing steel set		
4. Entire area where anti-seep collar(s) will come in contact with pipe coated with mastic or other approved waterproof sealant		
5. Low cradle and bottom half of anti-seep collar installed as monolithic pour and of an approved mix		
6. Upper half of anti-seep collar(s) formed with reinforcing steel set		
7. Concrete for collar of an approved mix and vibrated into place (protected from freezing while curing, if necessary)		
8. Forms stripped and collar inspected for honeycomb prior to backfilling. Parge if necessary.		
C. Backfilling		
Fill placed in maximum 8 inch lifts		
Backfill taken minimum 2 feet above top of anti-seep collar elevation before traversing with heavy equipment		

CONSTRUCTION SEQUENCE	SATISFACTORY/ UNSATISFACTORY	COMMENTS
4. Riser / Outlet Structure Installation		
Riser located within embankment		
A. Metal riser		
Riser base excavated or formed on stable subgrade to design dimensions		
Set on blocks to design elevations and plumbed		
Reinforcing bars placed at right angles and projecting into sides of riser		
Concrete poured so as to fill inside of riser to invert of barrel		
B. Pre-cast concrete structure		
Dry and stable subgrade		
Riser base set to design elevation		
If more than one section, no spalling in gasket interface area; gasket or approved caulking material placed securely		
Watertight and structurally sound collar or gasket joint where structure connects to pipe spillway		
C. Poured concrete structure		
Footing excavated or formed on stable subgrade, to design dimensions with reinforcing steel set		
Structure formed to design dimensions, with reinforcing steel set as per plan		
Concrete of an approved mix and vibrated into place (protected from freezing while curing, if necessary)		
Forms stripped & inspected for "honeycomb" prior to backfilling; pare if necessary		

CONSTRUCTION SEQUENCE	SATISFACTORY/ UNSATISFACTORY	COMMENTS
5. Embankment Construction		
Fill material		
Compaction		
Embankment		
1. Fill placed in specified lifts and compacted with appropriate equipment		
2. Constructed to design cross-section, side slopes and top width		
3. Constructed to design elevation plus allowance for settlement		
6. Impounded Area Construction		
Excavated / graded to design contours and side slopes		
Inlet pipes have adequate outfall protection		
Forebay(s)		
Pond benches		
7. Earth Emergency Spillway Construction		
Spillway located in cut or structurally stabilized with riprap, gabions, concrete, etc.		
Excavated to proper cross-section, side slopes and bottom width		
Entrance channel, crest, and exit channel constructed to design grades and elevations		

CONSTRUCTION SEQUENCE	SATISFACTORY / UNSATISFACTORY	COMMENTS
8. Outlet Protection		
A. End section		
Securely in place and properly backfilled		
B. Endwall		
Footing excavated or formed on stable subgrade, to design dimensions and reinforcing steel set, if specified		
Endwall formed to design dimensions with reinforcing steel set as per plan		
Concrete of an approved mix and vibrated into place (protected from freezing, if necessary)		
Forms stripped and structure inspected for "honeycomb" prior to backfilling; parge if necessary		
C. Riprap apron / channel		
Apron / channel excavated to design cross-section with proper transition to existing ground		
Filter fabric in place		
Stone sized as per plan and uniformly place at the thickness specified		
9. Vegetative Stabilization		
Approved seed mixture or sod		
Proper surface preparation and required soil amendments		
Excelsior mat or other stabilization, as per plan		

CONSTRUCTION SEQUENCE	SATISFACTORY/ UNSATISFACTORY	COMMENTS
10. Miscellaneous		
Drain for ponds having a permanent pool		
Trash rack / anti-vortex device secured to outlet structure		
Trash protection for low flow pipes, orifices, etc.		
Fencing (when required)		
Access road		
Set aside for clean-out maintenance		
11. Stormwater Wetlands		
Adequate water balance		
Variety of depth zones present		
Approved pondscaping plan in place Reinforcement budget for additional plantings		
Plants and materials ordered 6 months prior to construction		
Construction planned to allow for adequate planting and establishment of plant community (April-June planting window)		
Wetland buffer area preserved to maximum extent possible		

Comments:

Actions to be Taken:

Bioretention Construction Inspection Checklist

Project:
 Location:
 Site Status:

Date:

Time:

Inspector:

CONSTRUCTION SEQUENCE	SATISFACTORY/ UNSATISFACTORY	COMMENTS
1. Pre-Construction		
Pre-construction meeting		
Runoff diverted		
Facility area cleared		
If designed as exfilter, soil testing for permeability		
Facility location staked out		
2. Excavation		
Size and location		
Lateral slopes completely level		
If designed as exfilter, ensure that excavation does not compact susoils.		
Longitudinal slopes within design range		

CONSTRUCTION SEQUENCE	SATISFACTORY / UNSATISFACTORY	COMMENTS
3. Structural Components		
Stone diaphragm installed correctly		
Outlets installed correctly		
Underdrain		
Pretreatment devices installed		
Soil bed composition and texture		
4. Vegetation		
Complies with planting specs		
Topsoil adequate in composition and placement		
Adequate erosion control measures in place		
5. Final Inspection		
Dimensions		
Proper stone diaphragm		
Proper outlet		
Soil/ filter bed permeability testing		
Effective stand of vegetation and stabilization		
Construction generated sediments removed		
Contributing watershed stabilized before flow is diverted to the practice		

Comments:

Actions to be Taken:

STORMWATER POND MAINTENANCE AND INSPECTION CHECKLIST

Section A: General Information

Site:	NYSDEC SPDES Permit No.:
Site Location:	Stormwater Pond ID:
Date:	Time:
Weather:	
Inspector:	

Section B: Embankment and emergency spillway

Maintenance Item	Satisfactory	Unsatisfactory	N/A	Comments
1. Vegetation and ground cover adequate	<input type="checkbox"/>	<input type="checkbox"/>	<input type="checkbox"/>	
2. Embankment erosion	<input type="checkbox"/>	<input type="checkbox"/>	<input type="checkbox"/>	
3. Animal burrows	<input type="checkbox"/>	<input type="checkbox"/>	<input type="checkbox"/>	
4. Unauthorized planting	<input type="checkbox"/>	<input type="checkbox"/>	<input type="checkbox"/>	
5. Cracking, bulging, or sliding of berm	<input type="checkbox"/>	<input type="checkbox"/>	<input type="checkbox"/>	
a. Upstream face	<input type="checkbox"/>	<input type="checkbox"/>	<input type="checkbox"/>	
b. Downstream face	<input type="checkbox"/>	<input type="checkbox"/>	<input type="checkbox"/>	
c. At or beyond toe downstream	<input type="checkbox"/>	<input type="checkbox"/>	<input type="checkbox"/>	
upstream	<input type="checkbox"/>	<input type="checkbox"/>	<input type="checkbox"/>	
d. Emergency spillway	<input type="checkbox"/>	<input type="checkbox"/>	<input type="checkbox"/>	
6. Pond, toe & chimney drains clear and functioning	<input type="checkbox"/>	<input type="checkbox"/>	<input type="checkbox"/>	
7. Seeps/leaks on downstream face	<input type="checkbox"/>	<input type="checkbox"/>	<input type="checkbox"/>	
8. Slope protection or riprap failure	<input type="checkbox"/>	<input type="checkbox"/>	<input type="checkbox"/>	
9. Emergency spillway clear of obstructions and debris	<input type="checkbox"/>	<input type="checkbox"/>	<input type="checkbox"/>	
10. Other (specify)	<input type="checkbox"/>	<input type="checkbox"/>	<input type="checkbox"/>	

Section C: Outlet Structure

Maintenance Item	Satisfactory	Unsatisfactory	N/A	Comments
1. Pipe Type: Size Reinforced concrete ___ Corrugated metal ___ HDPE ___	<input type="checkbox"/>	<input type="checkbox"/>	<input type="checkbox"/>	
2. Low flow orifice obstructed	<input type="checkbox"/>	<input type="checkbox"/>	<input type="checkbox"/>	
3. Low flow trash rack. a. Debris removal necessary	<input type="checkbox"/>	<input type="checkbox"/>	<input type="checkbox"/>	
b. Corrosion	<input type="checkbox"/>	<input type="checkbox"/>	<input type="checkbox"/>	

**STORMWATER POND
MAINTENANCE AND INSPECTION CHECKLIST**

4. Weir trash rack maintenance a. Debris removal necessary	<input type="checkbox"/>	<input type="checkbox"/>	<input type="checkbox"/>	
b. Corrosion	<input type="checkbox"/>	<input type="checkbox"/>	<input type="checkbox"/>	
5. Excessive sediment accumulation inside outlet structure	<input type="checkbox"/>	<input type="checkbox"/>	<input type="checkbox"/>	
6. Concrete/masonry condition outlet structure and barrels a. cracks or displacement	<input type="checkbox"/>	<input type="checkbox"/>	<input type="checkbox"/>	
b. Minor spalling (<1")	<input type="checkbox"/>	<input type="checkbox"/>	<input type="checkbox"/>	
c. Major spalling (rebars exposed)	<input type="checkbox"/>	<input type="checkbox"/>	<input type="checkbox"/>	
d. Joint failures	<input type="checkbox"/>	<input type="checkbox"/>	<input type="checkbox"/>	
e. Water tightness	<input type="checkbox"/>	<input type="checkbox"/>	<input type="checkbox"/>	
7. Pipe condition	<input type="checkbox"/>	<input type="checkbox"/>	<input type="checkbox"/>	
8. Control valve a. Operation/exercised	<input type="checkbox"/>	<input type="checkbox"/>	<input type="checkbox"/>	
9. Pond drain valve a. Operation/exercised	<input type="checkbox"/>	<input type="checkbox"/>	<input type="checkbox"/>	
10. Chained/locked	<input type="checkbox"/>	<input type="checkbox"/>	<input type="checkbox"/>	
11. Outfall channels functioning	<input type="checkbox"/>	<input type="checkbox"/>	<input type="checkbox"/>	
12. Other (specify)	<input type="checkbox"/>	<input type="checkbox"/>	<input type="checkbox"/>	

Section D: Permanent Pool

Maintenance Item	Satisfactory	Unsatisfactory	N/A	Comments
1. Undesirable vegetative growth	<input type="checkbox"/>	<input type="checkbox"/>	<input type="checkbox"/>	
2. Floating or floatable debris removal required	<input type="checkbox"/>	<input type="checkbox"/>	<input type="checkbox"/>	
3. Visible pollution	<input type="checkbox"/>	<input type="checkbox"/>	<input type="checkbox"/>	
4. Shoreline problem	<input type="checkbox"/>	<input type="checkbox"/>	<input type="checkbox"/>	
5. Other (specify)	<input type="checkbox"/>	<input type="checkbox"/>	<input type="checkbox"/>	

Section E: Sediment Forebays

Maintenance Item	Satisfactory	Unsatisfactory	N/A	Comments
1. Sedimentation noted	<input type="checkbox"/>	<input type="checkbox"/>	<input type="checkbox"/>	
2. Sediment cleanout required (depth <50% design depth)	<input type="checkbox"/>	<input type="checkbox"/>	<input type="checkbox"/>	
3. Other (specify)	<input type="checkbox"/>	<input type="checkbox"/>	<input type="checkbox"/>	

**STORMWATER POND
MAINTENANCE AND INSPECTION CHECKLIST**

Section F: Dry Pond Areas

Maintenance Item	Satisfactory	Unsatisfactory	N/A	Comments
1. Vegetation Adequate	<input type="checkbox"/>	<input type="checkbox"/>	<input type="checkbox"/>	
2. Undesirable vegetative growth	<input type="checkbox"/>	<input type="checkbox"/>	<input type="checkbox"/>	
3. Undesirable woody vegetation	<input type="checkbox"/>	<input type="checkbox"/>	<input type="checkbox"/>	
4. Low flow channels clear of obstructions	<input type="checkbox"/>	<input type="checkbox"/>	<input type="checkbox"/>	
5. Standing water or wet areas	<input type="checkbox"/>	<input type="checkbox"/>	<input type="checkbox"/>	
6. Sediment and/or trash accumulation	<input type="checkbox"/>	<input type="checkbox"/>	<input type="checkbox"/>	
7. Other (specify)	<input type="checkbox"/>	<input type="checkbox"/>	<input type="checkbox"/>	

Section G: Condition of Outfalls

Maintenance Item	Satisfactory	Unsatisfactory	N/A	Comments
1. Riprap failures	<input type="checkbox"/>	<input type="checkbox"/>	<input type="checkbox"/>	
2. Slope erosion	<input type="checkbox"/>	<input type="checkbox"/>	<input type="checkbox"/>	
3. Storm drain pipes condition	<input type="checkbox"/>	<input type="checkbox"/>	<input type="checkbox"/>	
4. Endwalls/Headwalls	<input type="checkbox"/>	<input type="checkbox"/>	<input type="checkbox"/>	
5. Other (specify)	<input type="checkbox"/>	<input type="checkbox"/>	<input type="checkbox"/>	

Section H: Other (Misc.)

Maintenance Item	Satisfactory	Unsatisfactory	N/A	Comments
1. Any Encroachment on pond, wetland or easement area	<input type="checkbox"/>	<input type="checkbox"/>	<input type="checkbox"/>	
2. Complaints from residents	<input type="checkbox"/>	<input type="checkbox"/>	<input type="checkbox"/>	
3. Aesthetics	<input type="checkbox"/>	<input type="checkbox"/>	<input type="checkbox"/>	
a. Grass growing required				
b. Vandalism Repairs needed	<input type="checkbox"/>	<input type="checkbox"/>	<input type="checkbox"/>	
c. Other (specify)	<input type="checkbox"/>	<input type="checkbox"/>	<input type="checkbox"/>	
4. Conditions of maintenance access routes	<input type="checkbox"/>	<input type="checkbox"/>	<input type="checkbox"/>	
5. Any public hazards (specify)	<input type="checkbox"/>	<input type="checkbox"/>	<input type="checkbox"/>	

**STORMWATER POND
MAINTENANCE AND INSPECTION CHECKLIST**

Section I: Comments

Section J: Actions Required

**BIO-RETENTION AREA
MAINTENANCE AND INSPECTION CHECKLIST**

Section A: General Information

Site:	NYSDEC SPDES Permit No.:
Site Location:	Bio-Retention Area ID:
Date:	Time:
Weather:	
Inspector:	

Section B: Debris Cleanout

Maintenance Item	Satisfactory	Unsatisfactory	N/A	Comments
1. Bioretention and contributing areas clean of debris	<input type="checkbox"/>	<input type="checkbox"/>	<input type="checkbox"/>	
2. No dumping of yard waste or trash into practice	<input type="checkbox"/>	<input type="checkbox"/>	<input type="checkbox"/>	
3. Litter (branches, etc.) have been removed	<input type="checkbox"/>	<input type="checkbox"/>	<input type="checkbox"/>	
4. Other (specify)	<input type="checkbox"/>	<input type="checkbox"/>	<input type="checkbox"/>	

Section C: Vegetation

Maintenance Item	Satisfactory	Unsatisfactory	N/A	Comments
1. Plant height	<input type="checkbox"/>	<input type="checkbox"/>	<input type="checkbox"/>	
2. Fertilized per specifications	<input type="checkbox"/>	<input type="checkbox"/>	<input type="checkbox"/>	
3. No placement or growth of inappropriate plants	<input type="checkbox"/>	<input type="checkbox"/>	<input type="checkbox"/>	
4. Grass height not greater than 6 inches	<input type="checkbox"/>	<input type="checkbox"/>	<input type="checkbox"/>	
5. No evidence of erosion	<input type="checkbox"/>	<input type="checkbox"/>	<input type="checkbox"/>	
6. Other (specify)	<input type="checkbox"/>	<input type="checkbox"/>	<input type="checkbox"/>	

Section D: Check Dams/Energy Dissipaters/Outlet Structure

Maintenance Item	Satisfactory	Unsatisfactory	N/A	Comments
1. No evidence of sediment buildup	<input type="checkbox"/>	<input type="checkbox"/>	<input type="checkbox"/>	
2. Sumps should not be more than 50% full of sediment	<input type="checkbox"/>	<input type="checkbox"/>	<input type="checkbox"/>	
3. No evidence of erosion at downstream toe of structure	<input type="checkbox"/>	<input type="checkbox"/>	<input type="checkbox"/>	
4. Integrity of structure	<input type="checkbox"/>	<input type="checkbox"/>	<input type="checkbox"/>	
5. Cleaning necessary	<input type="checkbox"/>	<input type="checkbox"/>	<input type="checkbox"/>	
6. Other (Specify)	<input type="checkbox"/>	<input type="checkbox"/>	<input type="checkbox"/>	

**BIO-RETENTION AREA
MAINTENANCE AND INSPECTION CHECKLIST**

Section E: Dewatering

Maintenance Item	Satisfactory	Unsatisfactory	N/A	Comments
1. Dewaterers between storms within 2 days	<input type="checkbox"/>	<input type="checkbox"/>	<input type="checkbox"/>	
2. No evidence of standing water	<input type="checkbox"/>	<input type="checkbox"/>	<input type="checkbox"/>	
3. Other (specify)	<input type="checkbox"/>	<input type="checkbox"/>	<input type="checkbox"/>	

Section F: Sediment Deposition/Pre-Treatment

Maintenance Item	Satisfactory	Unsatisfactory	N/A	Comments
1. Sediments should not be >1" deep	<input type="checkbox"/>	<input type="checkbox"/>	<input type="checkbox"/>	
2. Gravel Diaphragm Condition	<input type="checkbox"/>	<input type="checkbox"/>	<input type="checkbox"/>	
3. Grass Filter Condition	<input type="checkbox"/>	<input type="checkbox"/>	<input type="checkbox"/>	
4. Other (specify)	<input type="checkbox"/>	<input type="checkbox"/>	<input type="checkbox"/>	

Section G: Outlet/Overflow Spillway

Maintenance Item	Satisfactory	Unsatisfactory	N/A	Comments
1. Good Condition, no need for repair	<input type="checkbox"/>	<input type="checkbox"/>	<input type="checkbox"/>	
2. No evidence of erosion	<input type="checkbox"/>	<input type="checkbox"/>	<input type="checkbox"/>	
3. No evidence of any blockages	<input type="checkbox"/>	<input type="checkbox"/>	<input type="checkbox"/>	
4. Other (specify)	<input type="checkbox"/>	<input type="checkbox"/>	<input type="checkbox"/>	

Section H: Integrity of Filter Bed

Maintenance Item	Satisfactory	Unsatisfactory	N/A	Comments
1. Filter bed has not been blocked or filled inappropriately	<input type="checkbox"/>	<input type="checkbox"/>	<input type="checkbox"/>	
2. Other (specify)	<input type="checkbox"/>	<input type="checkbox"/>	<input type="checkbox"/>	

Section I: Comments

Section J: Actions Required

CATCH BASIN MAINTENANCE AND INSPECTION CHECKLIST

Section A: General Information

Site:	NYSDEC SPDES Permit No.:
Site Location:	
Date:	Time:
Weather:	
Inspector:	

Section B: Catch Basin Conditions

CB ID.	<input type="checkbox"/> Standing Water <input type="checkbox"/> Cleaning Necessary <input type="checkbox"/> Sump <input type="checkbox"/> Trash/debris <input type="checkbox"/> Repairs Necessary <input type="checkbox"/> Pipe Damage <input type="checkbox"/> Sediment <input type="checkbox"/> Grate Damaged <input type="checkbox"/> Structure Damaged
CB Location:	
Notes:	
CB ID.	<input type="checkbox"/> Standing Water <input type="checkbox"/> Cleaning Necessary <input type="checkbox"/> Sump <input type="checkbox"/> Trash/debris <input type="checkbox"/> Repairs Necessary <input type="checkbox"/> Pipe Damage <input type="checkbox"/> Sediment <input type="checkbox"/> Grate Damaged <input type="checkbox"/> Structure Damaged
CB Location:	
Notes:	
CB ID.	<input type="checkbox"/> Standing Water <input type="checkbox"/> Cleaning Necessary <input type="checkbox"/> Sump <input type="checkbox"/> Trash/debris <input type="checkbox"/> Repairs Necessary <input type="checkbox"/> Pipe Damage <input type="checkbox"/> Sediment <input type="checkbox"/> Grate Damaged <input type="checkbox"/> Structure Damaged
CB Location:	
Notes:	
CB ID.	<input type="checkbox"/> Standing Water <input type="checkbox"/> Cleaning Necessary <input type="checkbox"/> Sump <input type="checkbox"/> Trash/debris <input type="checkbox"/> Repairs Necessary <input type="checkbox"/> Pipe Damage <input type="checkbox"/> Sediment <input type="checkbox"/> Grate Damaged <input type="checkbox"/> Structure Damaged
CB Location:	
Notes:	

CATCH BASIN MAINTENANCE AND INSPECTION CHECKLIST

CB ID.	<input type="checkbox"/> Standing Water <input type="checkbox"/> Cleaning Necessary <input type="checkbox"/> Sump
CB Location:	<input type="checkbox"/> Trash/debris <input type="checkbox"/> Repairs Necessary <input type="checkbox"/> Pipe Damage <input type="checkbox"/> Sediment <input type="checkbox"/> Grate Damaged <input type="checkbox"/> Structure Damaged
Notes:	
CB ID.	<input type="checkbox"/> Standing Water <input type="checkbox"/> Cleaning Necessary <input type="checkbox"/> Sump
CB Location:	<input type="checkbox"/> Trash/debris <input type="checkbox"/> Repairs Necessary <input type="checkbox"/> Pipe Damage <input type="checkbox"/> Sediment <input type="checkbox"/> Grate Damaged <input type="checkbox"/> Structure Damaged
Notes:	
CB ID.	<input type="checkbox"/> Standing Water <input type="checkbox"/> Cleaning Necessary <input type="checkbox"/> Sump
CB Location:	<input type="checkbox"/> Trash/debris <input type="checkbox"/> Repairs Necessary <input type="checkbox"/> Pipe Damage <input type="checkbox"/> Sediment <input type="checkbox"/> Grate Damaged <input type="checkbox"/> Structure Damaged
Notes:	
CB No.	<input type="checkbox"/> Standing Water <input type="checkbox"/> Cleaning Necessary <input type="checkbox"/> Sump
Location:	<input type="checkbox"/> Trash/debris <input type="checkbox"/> Repairs Necessary <input type="checkbox"/> Pipe Damage <input type="checkbox"/> Sediment <input type="checkbox"/> Grate Damaged <input type="checkbox"/> Structure Damaged
Notes:	
CB ID.	<input type="checkbox"/> Standing Water <input type="checkbox"/> Cleaning Necessary <input type="checkbox"/> Sump
CB Location:	<input type="checkbox"/> Trash/debris <input type="checkbox"/> Repairs Necessary <input type="checkbox"/> Pipe Damage <input type="checkbox"/> Sediment <input type="checkbox"/> Grate Damaged <input type="checkbox"/> Structure Damaged
Notes:	

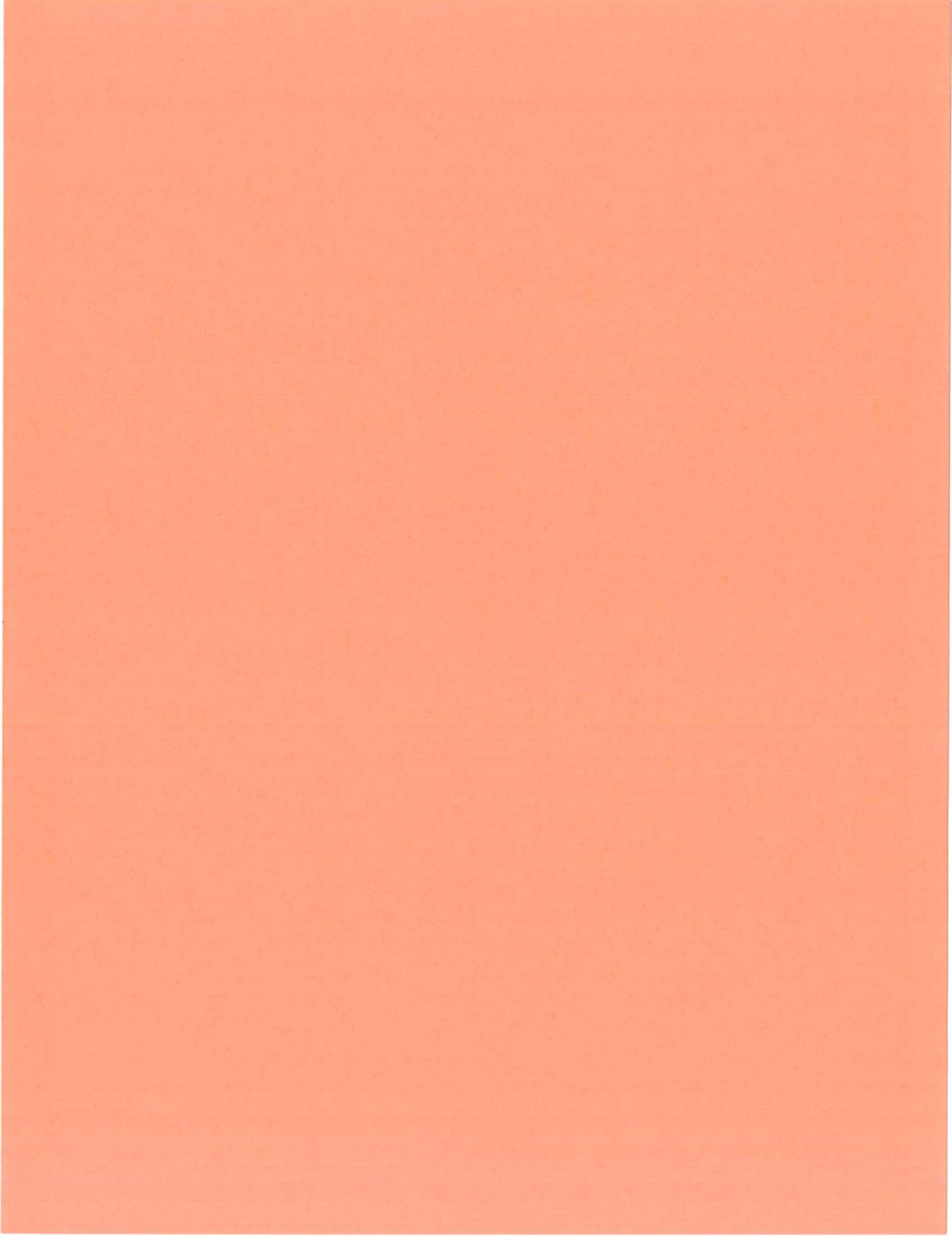

APPENDIX G

NOTICE OF INTENT
NOTICE OF TERMINATION
MS4 SWPPP ACCEPTANCE FORM

Project Site Information

Project/Site Name

C R H R e a l t y V I I I , L L C

Street Address (NOT P.O. BOX)

N Y S R o u t e 3 0 0

Side of Street

North South East West

City/Town/Village (THAT ISSUES BUILDING PERMIT)

T o w n o f N e w b u r g h

State Zip

N Y 1 2 5 5 0 -

County

O r a n g e

DEC Region

3

Name of Nearest Cross Street

O l d L i t t l e B r i t a i n R o a d

Distance to Nearest Cross Street (Feet)

2 0 0

Project In Relation to Cross Street

North South East West

Tax Map Numbers

Section-Block-Parcel
9 7 - 3 - 1 , 2 , 6 , 7 ,

Tax Map Numbers

8 , 2 6 , 4 - 1 - 7 2 . 2

1. Provide the Geographic Coordinates for the project site in NYTM Units. To do this you must go to the NYSDEC Stormwater Interactive Map on the DEC website at:

www.dec.ny.gov/insmaps/stormwater/viewer.htm

Zoom into your Project Location such that you can accurately click on the centroid of your site. Once you have located your project site, go to the tool boxes on the top and choose "i"(identify). Then click on the center of your site and a new window containing the X, Y coordinates in UTM will pop up. Transcribe these coordinates into the boxes below. For problems with the interactive map use the help function.

X Coordinates (Easting)

5 7 7 5 5 5

Y Coordinates (Northing)

4 5 9 4 3 8 4

2. What is the nature of this construction project?

New Construction

Redevelopment with increase in impervious area

Redevelopment with no increase in impervious area

3. Select the predominant land use for both pre and post development conditions.

SELECT ONLY ONE CHOICE FOR EACH

<p style="text-align: center;">Pre-Development Existing Land Use</p> <p><input type="radio"/> FOREST</p> <p><input type="radio"/> PASTURE/OPEN LAND</p> <p><input type="radio"/> CULTIVATED LAND</p> <p><input type="radio"/> SINGLE FAMILY HOME</p> <p><input type="radio"/> SINGLE FAMILY SUBDIVISION</p> <p><input type="radio"/> TOWN HOME RESIDENTIAL</p> <p><input type="radio"/> MULTIFAMILY RESIDENTIAL</p> <p><input type="radio"/> INSTITUTIONAL/SCHOOL</p> <p><input type="radio"/> INDUSTRIAL</p> <p><input type="radio"/> COMMERCIAL</p> <p><input type="radio"/> ROAD/HIGHWAY</p> <p><input type="radio"/> RECREATIONAL/SPORTS FIELD</p> <p><input type="radio"/> BIKE PATH/TRAIL</p> <p><input type="radio"/> LINEAR UTILITY</p> <p><input type="radio"/> PARKING LOT</p> <p><input checked="" type="radio"/> OTHER</p> <p style="border: 1px solid black; padding: 2px; display: inline-block;">A b a n d o n e d c o m m .</p>	<p style="text-align: center;">Post-Development Future Land Use</p> <p><input type="radio"/> SINGLE FAMILY HOME</p> <p><input type="radio"/> SINGLE FAMILY SUBDIVISION</p> <p><input type="radio"/> TOWN HOME RESIDENTIAL</p> <p><input type="radio"/> MULTIFAMILY RESIDENTIAL</p> <p><input type="radio"/> INSTITUTIONAL/SCHOOL</p> <p><input type="radio"/> INDUSTRIAL</p> <p><input checked="" type="radio"/> COMMERCIAL</p> <p><input type="radio"/> MUNICIPAL</p> <p><input type="radio"/> ROAD/HIGHWAY</p> <p><input type="radio"/> RECREATIONAL/SPORTS FIELD</p> <p><input type="radio"/> BIKE PATH/TRAIL</p> <p><input type="radio"/> LINEAR UTILITY (water, sewer, gas, etc.)</p> <p><input type="radio"/> PARKING LOT</p> <p><input type="radio"/> CLEARING/GRADING ONLY</p> <p><input type="radio"/> DEMOLITION, NO REDEVELOPMENT</p> <p><input type="radio"/> WELL DRILLING ACTIVITY *(Oil, Gas, etc.)</p> <p><input type="radio"/> OTHER</p> <p style="border: 1px solid black; display: inline-block; width: 100px; height: 15px;"></p>
--------------------------------------------------------------------------------------------------------------------------------------------------------------------------------------------------------------------------------------------------------------------------------------------------------------------------------------------------------------------------------------------------------------------------------------------------------------------------------------------------------------------------------------------------------------------------------------------------------------------------------------------------------------------------------------------------------------------------------------------------------------------------------------------------------------------------------------------------------------------------------------------------------------------------------------------------------------	------------------------------------------------------------------------------------------------------------------------------------------------------------------------------------------------------------------------------------------------------------------------------------------------------------------------------------------------------------------------------------------------------------------------------------------------------------------------------------------------------------------------------------------------------------------------------------------------------------------------------------------------------------------------------------------------------------------------------------------------------------------------------------------------------------------------------------------------------------------------------------------------------------------------------------------------------------------------------------------------------------------------------------------------------------------

Number of Lots

--	--	--

***Note:** for gas well drilling, non-high volume hydraulic fractured wells only

4. In accordance with the larger common plan of development or sale, enter the total project site area; the total area to be disturbed; existing impervious area to be disturbed (for redevelopment activities); and the future impervious area constructed within the disturbed area. (Round to the nearest tenth of an acre.)

Total Site Area	Total Area To Be Disturbed	Existing Impervious Area To Be Disturbed	Future Impervious Area Within Disturbed Area																				
<table border="1" style="border-collapse: collapse; width: 100px; height: 20px;"> <tr> <td style="width: 20px; height: 20px;"></td> <td style="width: 20px; height: 20px;"></td> <td style="width: 20px; height: 20px;"></td> <td style="width: 20px; height: 20px;"></td> <td style="width: 20px; height: 20px;"></td> </tr> </table>						<table border="1" style="border-collapse: collapse; width: 100px; height: 20px;"> <tr> <td style="width: 20px; height: 20px;"></td> <td style="width: 20px; height: 20px;"></td> <td style="width: 20px; height: 20px;"></td> <td style="width: 20px; height: 20px;"></td> <td style="width: 20px; height: 20px;"></td> </tr> </table>						<table border="1" style="border-collapse: collapse; width: 100px; height: 20px;"> <tr> <td style="width: 20px; height: 20px;"></td> <td style="width: 20px; height: 20px;"></td> <td style="width: 20px; height: 20px;"></td> <td style="width: 20px; height: 20px;"></td> <td style="width: 20px; height: 20px;"></td> </tr> </table>						<table border="1" style="border-collapse: collapse; width: 100px; height: 20px;"> <tr> <td style="width: 20px; height: 20px;"></td> <td style="width: 20px; height: 20px;"></td> <td style="width: 20px; height: 20px;"></td> <td style="width: 20px; height: 20px;"></td> <td style="width: 20px; height: 20px;"></td> </tr> </table>					

5. Do you plan to disturb more than 5 acres of soil at any one time? Yes No

6. Indicate the percentage of each Hydrologic Soil Group(HSG) at the site.

<p>A</p> <table border="1" style="border-collapse: collapse; width: 60px; height: 20px;"> <tr> <td style="width: 20px; height: 20px;"></td> <td style="width: 20px; height: 20px;"></td> <td style="width: 20px; height: 20px;"></td> </tr> </table> <p>%</p>				<p>B</p> <table border="1" style="border-collapse: collapse; width: 60px; height: 20px;"> <tr> <td style="width: 20px; height: 20px;"></td> <td style="width: 20px; height: 20px;"></td> <td style="width: 20px; height: 20px;"></td> </tr> </table> <p>%</p>				<p>C</p> <table border="1" style="border-collapse: collapse; width: 60px; height: 20px;"> <tr> <td style="width: 20px; height: 20px;"></td> <td style="width: 20px; height: 20px;"></td> <td style="width: 20px; height: 20px;"></td> </tr> </table> <p>%</p>				<p>D</p> <table border="1" style="border-collapse: collapse; width: 60px; height: 20px;"> <tr> <td style="width: 20px; height: 20px;"></td> <td style="width: 20px; height: 20px;"></td> <td style="width: 20px; height: 20px;"></td> </tr> </table> <p>%</p>			

7. Is this a phased project? Yes No

8. Enter the planned start and end dates of the disturbance activities.

	<p>Start Date</p> <table border="1" style="border-collapse: collapse; width: 150px; height: 20px;"> <tr> <td style="width: 20px; height: 20px;"></td> <td style="width: 20px; height: 20px;"></td> <td style="width: 20px; height: 20px;"></td> <td style="width: 20px; height: 20px;"></td> <td style="width: 20px; height: 20px;"></td> <td style="width: 20px; height: 20px;"></td> <td style="width: 20px; height: 20px;"></td> <td style="width: 20px; height: 20px;"></td> </tr> </table>									<p>End Date</p> <table border="1" style="border-collapse: collapse; width: 150px; height: 20px;"> <tr> <td style="width: 20px; height: 20px;"></td> <td style="width: 20px; height: 20px;"></td> <td style="width: 20px; height: 20px;"></td> <td style="width: 20px; height: 20px;"></td> <td style="width: 20px; height: 20px;"></td> <td style="width: 20px; height: 20px;"></td> <td style="width: 20px; height: 20px;"></td> <td style="width: 20px; height: 20px;"></td> </tr> </table>								

15. Does the site runoff enter a separate storm sewer system (including roadside drains, swales, ditches, culverts, etc)? Yes No Unknown

16. What is the name of the municipality/entity that owns the separate storm sewer system?

Two rows of empty grid boxes for text entry.

17. Does any runoff from the site enter a sewer classified as a Combined Sewer? Yes No Unknown

18. Will future use of this site be an agricultural property as defined by the NYS Agriculture and Markets Law? Yes No

19. Is this property owned by a state authority, state agency, federal government or local government? Yes No

20. Is this a remediation project being done under a Department approved work plan? (i.e. CERCLA, RCRA, Voluntary Cleanup Agreement, etc.) Yes No

21. Has the required Erosion and Sediment Control component of the SWPPP been developed in conformance with the current NYS Standards and Specifications for Erosion and Sediment Control (aka Blue Book)? Yes No

22. Does this construction activity require the development of a SWPPP that includes the post-construction stormwater management practice component (i.e. Runoff Reduction, Water Quality and Quantity Control practices/techniques)? Yes No
If No, skip questions 23 and 27-39.

23. Has the post-construction stormwater management practice component of the SWPPP been developed in conformance with the current NYS Stormwater Management Design Manual? Yes No

Post-construction Stormwater Management Practice (SMP) Requirements

Important: Completion of Questions 27-39 is not required if response to Question 22 is No.

27. Identify all site planning practices that were used to prepare the final site plan/layout for the project.

- Preservation of Undisturbed Areas
- Preservation of Buffers
- Reduction of Clearing and Grading
- Locating Development in Less Sensitive Areas
- Roadway Reduction
- Sidewalk Reduction
- Driveway Reduction
- Cul-de-sac Reduction
- Building Footprint Reduction
- Parking Reduction

27a. Indicate which of the following soil restoration criteria was used to address the requirements in Section 5.1.6("Soil Restoration") of the Design Manual (2010 version).

- All disturbed areas will be restored in accordance with the Soil Restoration requirements in Table 5.3 of the Design Manual (see page 5-22).
- Compacted areas were considered as impervious cover when calculating the **WQv Required**, and the compacted areas were assigned a post-construction Hydrologic Soil Group (HSG) designation that is one level less permeable than existing conditions for the hydrology analysis.

28. Provide the total Water Quality Volume (WQv) required for this project (based on final site plan/layout).

Total WQv Required

. acre-feet

29. Identify the RR techniques (Area Reduction), RR techniques (Volume Reduction) and Standard SMPs with RRv Capacity in Table 1 (See Page 9) that were used to reduce the Total WQv Required(#28).

Also, provide in Table 1 the total impervious area that contributes runoff to each technique/practice selected. For the Area Reduction Techniques, provide the total contributing area (includes pervious area) and, if applicable, the total impervious area that contributes runoff to the technique/practice.

Note: Redevelopment projects shall use Tables 1 and 2 to identify the SMPs used to treat and/or reduce the WQv required. If runoff reduction techniques will not be used to reduce the required WQv, skip to question 33a after identifying the SMPs.

Table 1 - Runoff Reduction (RR) Techniques and Standard Stormwater Management Practices (SMPs)

<u>RR Techniques (Area Reduction)</u>	<u>Total Contributing Area (acres)</u>		<u>Total Contributing Impervious Area (acres)</u>	
<input type="radio"/> Conservation of Natural Areas (RR-1) ...	<input type="text"/>	<input type="text"/>	and/or	<input type="text"/>
<input type="radio"/> Sheetflow to Riparian Buffers/Filters Strips (RR-2)	<input type="text"/>	<input type="text"/>	and/or	<input type="text"/>
<input checked="" type="radio"/> Tree Planting/Tree Pit (RR-3)	<input type="text"/>	<input type="text"/>	and/or	<input type="text"/>
<input type="radio"/> Disconnection of Rooftop Runoff (RR-4) ..	<input type="text"/>	<input type="text"/>	and/or	<input type="text"/>
<u>RR Techniques (Volume Reduction)</u>				
<input type="radio"/> Vegetated Swale (RR-5)	<input type="text"/>	<input type="text"/>		<input type="text"/>
<input checked="" type="radio"/> Rain Garden (RR-6)	<input type="text"/>	<input type="text"/>		<input type="text"/>
<input type="radio"/> Stormwater Planter (RR-7)	<input type="text"/>	<input type="text"/>		<input type="text"/>
<input type="radio"/> Rain Barrel/Cistern (RR-8)	<input type="text"/>	<input type="text"/>		<input type="text"/>
<input checked="" type="radio"/> Porous Pavement (RR-9)	<input type="text"/>	<input type="text"/>		<input type="text"/>
<input type="radio"/> Green Roof (RR-10)	<input type="text"/>	<input type="text"/>		<input type="text"/>
<u>Standard SMPs with RRv Capacity</u>				
<input type="radio"/> Infiltration Trench (I-1)	<input type="text"/>	<input type="text"/>		<input type="text"/>
<input type="radio"/> Infiltration Basin (I-2)	<input type="text"/>	<input type="text"/>		<input type="text"/>
<input type="radio"/> Dry Well (I-3)	<input type="text"/>	<input type="text"/>		<input type="text"/>
<input type="radio"/> Underground Infiltration System (I-4)	<input type="text"/>	<input type="text"/>		<input type="text"/>
<input checked="" type="radio"/> Bioretention (F-5)	<input type="text"/>	<input type="text"/>		<input type="text"/>
<input type="radio"/> Dry Swale (O-1)	<input type="text"/>	<input type="text"/>		<input type="text"/>
<u>Standard SMPs</u>				
<input type="radio"/> Micropool Extended Detention (P-1)	<input type="text"/>	<input type="text"/>		<input type="text"/>
<input checked="" type="radio"/> Wet Pond (P-2)	<input type="text"/>	<input type="text"/>		<input type="text"/>
<input type="radio"/> Wet Extended Detention (P-3)	<input type="text"/>	<input type="text"/>		<input type="text"/>
<input type="radio"/> Multiple Pond System (P-4)	<input type="text"/>	<input type="text"/>		<input type="text"/>
<input type="radio"/> Pocket Pond (P-5)	<input type="text"/>	<input type="text"/>		<input type="text"/>
<input type="radio"/> Surface Sand Filter (F-1)	<input type="text"/>	<input type="text"/>		<input type="text"/>
<input type="radio"/> Underground Sand Filter (F-2)	<input type="text"/>	<input type="text"/>		<input type="text"/>
<input type="radio"/> Perimeter Sand Filter (F-3)	<input type="text"/>	<input type="text"/>		<input type="text"/>
<input type="radio"/> Organic Filter (F-4)	<input type="text"/>	<input type="text"/>		<input type="text"/>
<input type="radio"/> Shallow Wetland (W-1)	<input type="text"/>	<input type="text"/>		<input type="text"/>
<input type="radio"/> Extended Detention Wetland (W-2)	<input type="text"/>	<input type="text"/>		<input type="text"/>
<input type="radio"/> Pond/Wetland System (W-3)	<input type="text"/>	<input type="text"/>		<input type="text"/>
<input type="radio"/> Pocket Wetland (W-4)	<input type="text"/>	<input type="text"/>		<input type="text"/>
<input type="radio"/> Wet Swale (O-2)	<input type="text"/>	<input type="text"/>		<input type="text"/>

33. Identify the Standard SMPs in Table 1 and, if applicable, the Alternative SMPs in Table 2 that were used to treat the remaining total WQv(=Total WQv Required in 28 - Total RRv Provided in 30).

Also, provide in Table 1 and 2 the total impervious area that contributes runoff to each practice selected.

Note: Use Tables 1 and 2 to identify the SMPs used on Redevelopment projects.

- 33a. Indicate the Total WQv provided (i.e. WQv treated) by the SMPs identified in question #33 and Standard SMPs with RRv Capacity identified in question 29.

WQv Provided

		0	.	3	5	3
--	--	---	---	---	---	---

 acre-feet

Note: For the standard SMPs with RRv capacity, the WQv provided by each practice = the WQv calculated using the contributing drainage area to the practice - RRv provided by the practice. (See Table 3.5 in Design Manual)

34. Provide the sum of the Total RRv provided (#30) and the WQv provided (#33a).

		0	.	6	3	9
--	--	---	---	---	---	---

35. Is the sum of the RRv provided (#30) and the WQv provided (#33a) greater than or equal to the total WQv required (#28)? Yes No

If Yes, go to question 36.

If No, sizing criteria has not been met, so NOI can not be processed. SWPPP preparer must modify design to meet sizing criteria.

36. Provide the total Channel Protection Storage Volume (CPv) required and provided or select waiver (36a), if applicable.

CPv Required

		0	.	8	8	8
--	--	---	---	---	---	---

 acre-feet

CPv Provided

		0	.	8	8	8
--	--	---	---	---	---	---

 acre-feet

- 36a. The need to provide channel protection has been waived because:

Site discharges directly to tidal waters or a fifth order or larger stream.

Reduction of the total CPv is achieved on site through runoff reduction techniques or infiltration systems.

37. Provide the Overbank Flood (Qp) and Extreme Flood (Qf) control criteria or select waiver (37a), if applicable.

Total Overbank Flood Control Criteria (Qp)

Pre-Development

	2	4	.	7	6	
--	---	---	---	---	---	--

 CFS

Post-development

	1	7	.	7	4	
--	---	---	---	---	---	--

 CFS

Total Extreme Flood Control Criteria (Qf)

Pre-Development

	3	9	.	4	2	
--	---	---	---	---	---	--

 CFS

Post-development

	2	9	.	8	0	
--	---	---	---	---	---	--

 CFS

Project Site Information

Project/Site Name

B r i t a i n P l a z a

Street Address (NOT P.O. BOX)

O l d L i t t l e B r i t a i n R o a d

Side of Street

North South East West

City/Town/Village (THAT ISSUES BUILDING PERMIT)

T o w n o f N e w b u r g h

State Zip

N Y 1 2 5 5 0 -

County

O r a n g e

DEC Region

3

Name of Nearest Cross Street

N Y S R o u t e 3 0 0

Distance to Nearest Cross Street (Feet)

2 7 0

Project In Relation to Cross Street

North South East West

Tax Map Numbers

Section-Block-Parcel

9 7 - 3 - 1 , 2 , 6

Tax Map Numbers

1. Provide the Geographic Coordinates for the project site in NYTM Units. To do this you **must** go to the NYSDEC Stormwater Interactive Map on the DEC website at:

www.dec.ny.gov/imsmaps/stormwater/viewer.htm

Zoom into your Project Location such that you can accurately click on the centroid of your site. Once you have located your project site, go to the tool boxes on the top and choose "i"(identify). Then click on the center of your site and a new window containing the X, Y coordinates in UTM will pop up. Transcribe these coordinates into the boxes below. For problems with the interactive map use the help function.

X Coordinates (Easting)

5 7 7 5 5 5

Y Coordinates (Northing)

4 5 9 4 4 9 3

2. What is the nature of this construction project?

New Construction

Redevelopment with increase in impervious area

Redevelopment with no increase in impervious area

3. Select the predominant land use for both pre and post development conditions.
SELECT ONLY ONE CHOICE FOR EACH

- Pre-Development Existing Land Use**
- FOREST
 - PASTURE/OPEN LAND
 - CULTIVATED LAND
 - SINGLE FAMILY HOME
 - SINGLE FAMILY SUBDIVISION
 - TOWN HOME RESIDENTIAL
 - MULTIFAMILY RESIDENTIAL
 - INSTITUTIONAL/SCHOOL
 - INDUSTRIAL
 - COMMERCIAL
 - ROAD/HIGHWAY
 - RECREATIONAL/SPORTS FIELD
 - BIKE PATH/TRAIL
 - LINEAR UTILITY
 - PARKING LOT
 - OTHER

A b a n d o n e d c o m m .

- Post-Development Future Land Use**
- SINGLE FAMILY HOME
 - SINGLE FAMILY SUBDIVISION
 - TOWN HOME RESIDENTIAL
 - MULTIFAMILY RESIDENTIAL
 - INSTITUTIONAL/SCHOOL
 - INDUSTRIAL
 - COMMERCIAL
 - MUNICIPAL
 - ROAD/HIGHWAY
 - RECREATIONAL/SPORTS FIELD
 - BIKE PATH/TRAIL
 - LINEAR UTILITY (water, sewer, gas, etc.)
 - PARKING LOT
 - CLEARING/GRADING ONLY
 - DEMOLITION, NO REDEVELOPMENT
 - WELL DRILLING ACTIVITY *(Oil, Gas, etc.)
 - OTHER

Number of Lots

*Note: for gas well drilling, non-high volume hydraulic fractured wells only

4. In accordance with the larger common plan of development or sale, enter the total project site area; the total area to be disturbed; existing impervious area to be disturbed (for redevelopment activities); and the future impervious area constructed within the disturbed area. (Round to the nearest tenth of an acre.)

Total Site Area	Total Area To Be Disturbed	Existing Impervious Area To Be Disturbed	Future Impervious Area Within Disturbed Area
<input type="text"/> <input type="text"/> <input type="text"/> 8 . 6	<input type="text"/> <input type="text"/> <input type="text"/> 8 . 7	<input type="text"/> <input type="text"/> <input type="text"/> 1 . 3	<input type="text"/> <input type="text"/> <input type="text"/> 5 . 7

5. Do you plan to disturb more than 5 acres of soil at any one time? Yes No

6. Indicate the percentage of each Hydrologic Soil Group (HSG) at the site.

A % B % C % D 1 0 0 %

7. Is this a phased project? Yes No

8. Enter the planned start and end dates of the disturbance activities.

Start Date: 6 / 1 / 2 0 1 4 - End Date: 1 2 / 1 / 2 0 1 5

9. Identify the nearest surface waterbody(ies) to which construction site runoff will discharge.

Name

L a k e W a s h i n g t o n

9a. Type of waterbody identified in Question 9?

- Wetland / State Jurisdiction On Site (Answer 9b)
- Wetland / State Jurisdiction Off Site
- Wetland / Federal Jurisdiction On Site (Answer 9b)
- Wetland / Federal Jurisdiction Off Site
- Stream / Creek On Site
- Stream / Creek Off Site
- River On Site
- River Off Site
- Lake On Site
- Lake Off Site
- Other Type On Site
- Other Type Off Site

Grid for identifying other type off site

9b. How was the wetland identified?

- Regulatory Map
- Delineated by Consultant
- Delineated by Army Corps of Engineers
- Other (identify)

Grid for identifying other type of wetland

10. Has the surface waterbody(ies) in question 9 been identified as a 303(d) segment in Appendix E of GP-0-10-001? Yes No

11. Is this project located in one of the Watersheds identified in Appendix C of GP-0-10-001? Yes No

12. Is the project located in one of the watershed areas associated with AA and AA-S classified waters? Yes No
If no, skip question 13.

13. Does this construction activity disturb land with no existing impervious cover and where the Soil Slope Phase is identified as an E or F on the USDA Soil Survey? Yes No
If Yes, what is the acreage to be disturbed?

Grid for acreage to be disturbed: [][][][] . []

14. Will the project disturb soils within a State regulated wetland or the protected 100 foot adjacent area? Yes No

Post-construction Stormwater Management Practice (SMP) Requirements

Important: Completion of Questions 27-39 is not required if response to Question 22 is No.

27. Identify all site planning practices that were used to prepare the final site plan/layout for the project.

- Preservation of Undisturbed Areas
- Preservation of Buffers
- Reduction of Clearing and Grading
- Locating Development in Less Sensitive Areas
- Roadway Reduction
- Sidewalk Reduction
- Driveway Reduction
- Cul-de-sac Reduction
- Building Footprint Reduction
- Parking Reduction

27a. Indicate which of the following soil restoration criteria was used to address the requirements in Section 5.1.6("Soil Restoration") of the Design Manual (2010 version).

- All disturbed areas will be restored in accordance with the Soil Restoration requirements in Table 5.3 of the Design Manual (see page 5-22).
- Compacted areas were considered as impervious cover when calculating the **WQv Required**, and the compacted areas were assigned a post-construction Hydrologic Soil Group (HSG) designation that is one level less permeable than existing conditions for the hydrology analysis.

28. Provide the total Water Quality Volume (WQv) required for this project (based on final site plan/layout).

Total WQv Required

. acre-feet

29. Identify the RR techniques (Area Reduction), RR techniques (Volume Reduction) and Standard SMPs with RRv Capacity in Table 1 (See Page 9) that were used to reduce the Total WQv Required (#28).

Also, provide in Table 1 the total impervious area that contributes runoff to each technique/practice selected. For the Area Reduction Techniques, provide the total contributing area (includes pervious area) and, if applicable, the total impervious area that contributes runoff to the technique/practice.

Note: Redevelopment projects shall use Tables 1 and 2 to identify the SMPs used to treat and/or reduce the WQv required. If runoff reduction techniques will not be used to reduce the required WQv, skip to question 33a after identifying the SMPs.

Table 1 - Runoff Reduction (RR) Techniques and Standard Stormwater Management Practices (SMPs)

<u>RR Techniques (Area Reduction)</u>	<u>Total Contributing Area (acres)</u>		<u>Total Contributing Impervious Area (acres)</u>	
<input type="radio"/> Conservation of Natural Areas (RR-1) ...	<input type="text"/>	<input type="text"/>	and/or	<input type="text"/>
<input type="radio"/> Sheetflow to Riparian Buffers/Filters Strips (RR-2)	<input type="text"/>	<input type="text"/>	and/or	<input type="text"/>
<input checked="" type="radio"/> Tree Planting/Tree Pit (RR-3)	<input type="text"/>	<input type="text"/>	and/or	<input type="text"/>
<input type="radio"/> Disconnection of Rooftop Runoff (RR-4) ..	<input type="text"/>	<input type="text"/>	and/or	<input type="text"/>
RR Techniques (Volume Reduction)				
<input type="radio"/> Vegetated Swale (RR-5)				
<input checked="" type="radio"/> Rain Garden (RR-6)			0	0 5 4
<input type="radio"/> Stormwater Planter (RR-7)				
<input type="radio"/> Rain Barrel/Cistern (RR-8)				
<input checked="" type="radio"/> Porous Pavement (RR-9)			1	5 7 4
<input type="radio"/> Green Roof (RR-10)				
Standard SMPs with RRv Capacity				
<input type="radio"/> Infiltration Trench (I-1)				
<input type="radio"/> Infiltration Basin (I-2)				
<input type="radio"/> Dry Well (I-3)				
<input type="radio"/> Underground Infiltration System (I-4)				
<input checked="" type="radio"/> Bioretention (F-5)			3	2 9 9
<input type="radio"/> Dry Swale (O-1)				
Standard SMPs				
<input type="radio"/> Micropool Extended Detention (P-1)				
<input checked="" type="radio"/> Wet Pond (P-2)			7	8 7 5
<input type="radio"/> Wet Extended Detention (P-3)				
<input type="radio"/> Multiple Pond System (P-4)				
<input type="radio"/> Pocket Pond (P-5)				
<input type="radio"/> Surface Sand Filter (F-1)				
<input type="radio"/> Underground Sand Filter (F-2)				
<input type="radio"/> Perimeter Sand Filter (F-3)				
<input type="radio"/> Organic Filter (F-4)				
<input type="radio"/> Shallow Wetland (W-1)				
<input type="radio"/> Extended Detention Wetland (W-2)				
<input type="radio"/> Pond/Wetland System (W-3)				
<input type="radio"/> Pocket Wetland (W-4)				
<input type="radio"/> Wet Swale (O-2)				

33. Identify the Standard SMPs in Table 1 and, if applicable, the Alternative SMPs in Table 2 that were used to treat the remaining total WQv(=Total WQv Required in 28 - Total RRv Provided in 30).

Also, provide in Table 1 and 2 the total impervious area that contributes runoff to each practice selected.

Note: Use Tables 1 and 2 to identify the SMPs used on Redevelopment projects.

33a. Indicate the Total WQv provided (i.e. WQv treated) by the SMPs identified in question #33 and Standard SMPs with RRv Capacity identified in question 29.

WQv Provided

		0	.	3	5	3
--	--	---	---	---	---	---

 acre-feet

Note: For the standard SMPs with RRv capacity, the WQv provided by each practice = the WQv calculated using the contributing drainage area to the practice - RRv provided by the practice. (See Table 3.5 in Design Manual)

34. Provide the sum of the Total RRv provided (#30) and the WQv provided (#33a).

		0	.	6	3	9
--	--	---	---	---	---	---

35. Is the sum of the RRv provided (#30) and the WQv provided (#33a) greater than or equal to the total WQv required (#28)? Yes No

If Yes, go to question 36.
 If No, sizing criteria has not been met, so NOI can not be processed. SWPPP preparer must modify design to meet sizing criteria.

36. Provide the total Channel Protection Storage Volume (CPv) required and provided or select waiver (36a), if applicable.

CPv Required

		0	.	8	8	8
--	--	---	---	---	---	---

 acre-feet

CPv Provided

		0	.	8	8	8
--	--	---	---	---	---	---

 acre-feet

36a. The need to provide channel protection has been waived because:

- Site discharges directly to tidal waters or a fifth order or larger stream.
- Reduction of the total CPv is achieved on site through runoff reduction techniques or infiltration systems.

37. Provide the Overbank Flood (Qp) and Extreme Flood (Qf) control criteria or select waiver (37a), if applicable.

Total Overbank Flood Control Criteria (Qp)

Pre-Development

	2	4	.	7	6	
--	---	---	---	---	---	--

 CFS

Post-development

	1	7	.	7	4	
--	---	---	---	---	---	--

 CFS

Total Extreme Flood Control Criteria (Qf)

Pre-Development

	3	9	.	4	2	
--	---	---	---	---	---	--

 CFS

Post-development

	2	9	.	8	0	
--	---	---	---	---	---	--

 CFS



**New York State Department of Environmental Conservation
Division of Water
625 Broadway, 4th Floor
Albany, New York 12233-3505**

(NOTE: Submit completed form to address above)

**NOTICE OF TERMINATION for Storm Water Discharges Authorized
under the SPDES General Permit for Construction Activity**

Please indicate your permit identification number: NYR _____

I. Owner or Operator Information

1. Owner/Operator Name:

2. Street Address:

3. City/State/Zip:

4. Contact Person:

4a. Telephone:

5. Contact Person E-Mail:

II. Project Site Information

5. Project/Site Name:

6. Street Address:

7. City/Zip:

8. County:

III. Reason for Termination

9a. All disturbed areas have achieved final stabilization in accordance with the general permit and SWPPP.
*Date final stabilization completed (month/year): _____

9b. Permit coverage has been transferred to new owner/operator. Indicate new owner/operator's permit identification number: NYR _____
(Note: Permit coverage can not be terminated by owner identified in I.1. above until new owner/operator obtains coverage under the general permit)

9c. Other (Explain on Page 2)

IV. Final Site Information:

10a. Did this construction activity require the development of a SWPPP that includes post-construction stormwater management practices? yes no (If no, go to question 10f.)

10b. Have all post-construction stormwater management practices included in the final SWPPP been constructed? yes no (If no, explain on Page 2)

10c. Identify the entity responsible for long-term operation and maintenance of practice(s)?

**NOTICE OF TERMINATION for Storm Water Discharges Authorized under the
SPDES General Permit for Construction Activity - continued**

10d. Has the entity responsible for long-term operation and maintenance been given a copy of the operation and maintenance plan required by the general permit? yes no

10e. Indicate the method used to ensure long-term operation and maintenance of the post-construction stormwater management practice(s):

- Post-construction stormwater management practice(s) and any right-of-way(s) needed to maintain practice(s) have been deeded to the municipality.
- Executed maintenance agreement is in place with the municipality that will maintain the post-construction stormwater management practice(s).
- For post-construction stormwater management practices that are privately owned, the deed of record has been modified to include a deed covenant that requires operation and maintenance of the practice(s) in accordance with the operation and maintenance plan.
- For post-construction stormwater management practices that are owned by a public or private institution (e.g. school, college, university), or government agency or authority, policy and procedures are in place that ensures operation and maintenance of the practice(s) in accordance with the operation and maintenance plan.

10f. Provide the total area of impervious surface (i.e. roof, pavement, concrete, gravel, etc.) constructed within the disturbance area? _____ (acres)

11. Is this project subject to the requirements of a regulated, traditional land use control MS4? yes no
(If Yes, complete section VI - "MS4 Acceptance" statement

V. Additional Information/Explanation:
(Use this section to answer questions 9c. and 10b., if applicable)

VI. MS4 Acceptance - MS4 Official (principal executive officer or ranking elected official) or Duly Authorized Representative (Note: Not required when 9b. is checked -transfer of coverage)

I have determined that it is acceptable for the owner or operator of the construction project identified in question 5 to submit the Notice of Termination at this time.

Printed Name:

Title/Position:

Signature:

Date:

**NOTICE OF TERMINATION for Storm Water Discharges Authorized under the
SPDES General Permit for Construction Activity - continued**

VII. Qualified Inspector Certification - Final Stabilization:

I hereby certify that all disturbed areas have achieved final stabilization as defined in the current version of the general permit, and that all temporary, structural erosion and sediment control measures have been removed. Furthermore, I understand that certifying false, incorrect or inaccurate information is a violation of the referenced permit and the laws of the State of New York and could subject me to criminal, civil and/or administrative proceedings.

Printed Name:

Title/Position:

Signature:

Date:

VIII. Qualified Inspector Certification - Post-construction Stormwater Management Practice(s):

I hereby certify that all post-construction stormwater management practices have been constructed in conformance with the SWPPP. Furthermore, I understand that certifying false, incorrect or inaccurate information is a violation of the referenced permit and the laws of the State of New York and could subject me to criminal, civil and/or administrative proceedings.

Printed Name:

Title/Position:

Signature:

Date:

IX. Owner or Operator Certification

I hereby certify that this document was prepared by me or under my direction or supervision. My determination, based upon my inquiry of the person(s) who managed the construction activity, or those persons directly responsible for gathering the information, is that the information provided in this document is true, accurate and complete. Furthermore, I understand that certifying false, incorrect or inaccurate information is a violation of the referenced permit and the laws of the State of New York and could subject me to criminal, civil and/or administrative proceedings.

Printed Name:

Title/Position:

Signature:

Date:

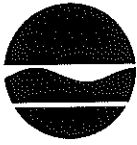

New York State Department of Environmental Conservation
Division of Water
625 Broadway, 4th Floor
Albany, New York 12233-3505

MS4 Stormwater Pollution Prevention Plan (SWPPP) Acceptance Form
for

Construction Activities Seeking Authorization Under SPDES General Permit

*(NOTE: Attach Completed Form to Notice Of Intent and Submit to Address Above)

I. Project Owner/Operator Information

1. Owner/Operator Name:

2. Contact Person:

3. Street Address:

4. City/State/Zip:

II. Project Site Information

5. Project/Site Name:

6. Street Address:

7. City/State/Zip:

III. Stormwater Pollution Prevention Plan (SWPPP) Review and Acceptance Information

8. SWPPP Reviewed by:

9. Title/Position:

10. Date Final SWPPP Reviewed and Accepted:

IV. Regulated MS4 Information

11. Name of MS4:

12. MS4 SPDES Permit Identification Number: NYR20A _____

13. Contact Person:

14. Street Address:

15. City/State/Zip:

16. Telephone Number:

(NYS DEC - MS4 SWPPP Acceptance Form - January 2010)

MS4 SWPPP Acceptance Form - continued

V. Certification Statement - MS4 Official (principal executive officer or ranking elected official) or Duly Authorized Representative

I hereby certify that the final Stormwater Pollution Prevention Plan (SWPPP) for the construction project identified in question 5 has been reviewed and meets the substantive requirements in the SPDES General Permit For Stormwater Discharges from Municipal Separate Storm Sewer Systems (MS4s).

Note: The MS4, through the acceptance of the SWPPP, assumes no responsibility for the accuracy and adequacy of the design included in the SWPPP. In addition, review and acceptance of the SWPPP by the MS4 does not relieve the owner/operator or their SWPPP preparer of responsibility or liability for errors or omissions in the plan.

Printed Name:

Title/Position:

Signature:

Date:

VI. Additional Information

Empty box for additional information.

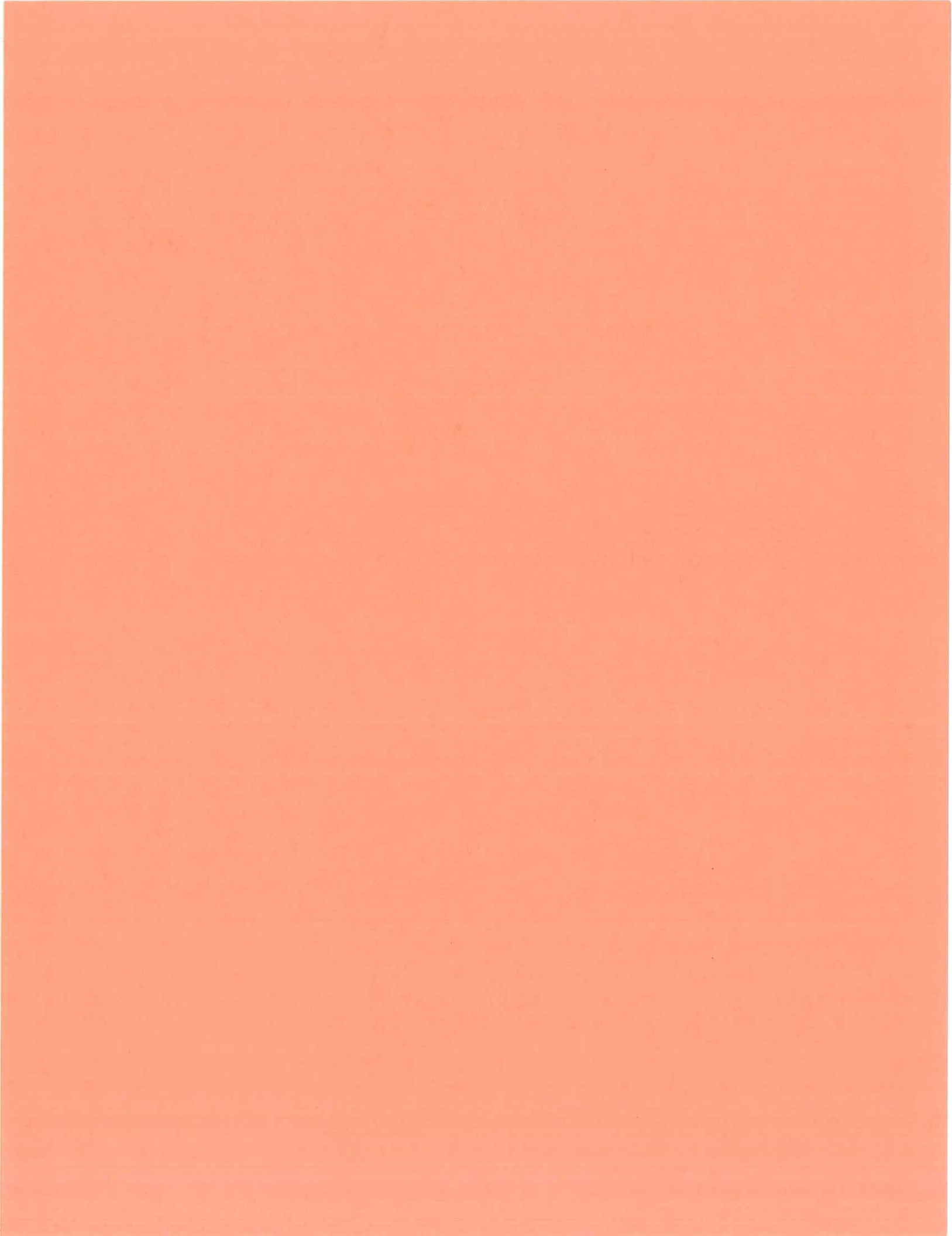

APPENDIX H

CONSTRUCTION SITE LOG BOOK
CONTRACTOR'S CERTIFICATION FORM

APPENDIX H

STATE POLLUTANT DISCHARGE ELIMINATION SYSTEM FOR CONSTRUCTION ACTIVITIES CONSTRUCTION SITE LOG BOOK

Table of Contents

- I. Pre-Construction Meeting Documents
 - a. Preamble to Site Assessment and Inspections
 - b. Operator's Certification
 - c. Qualified Professional's Credentials & Certification
 - d. Pre-Construction Site Assessment Checklist

- II. Construction Duration Inspections
 - a. Directions
 - b. Modification to the SWPPP

- III. Monthly Summary Reports

- IV. Monitoring, Reporting, and Three-Month Status Reports
 - a. Operator's Compliance Response Form

Properly completing forms such as those contained in Appendix H meet the inspection requirement of NYS-DEC SPDES GP for Construction Activities. Completed forms shall be kept on site at all times and made available to authorities upon request.

I. PRE-CONSTRUCTION MEETING DOCUMENTS

Project Name _____
Permit No. _____ Date of Authorization _____
Name of Operator _____
Prime Contractor _____

a. Preamble to Site Assessment and Inspections

The Following Information To Be Read By All Person's Involved in The Construction of Stormwater Related Activities:

The Operator agrees to have a qualified professional¹ conduct an assessment of the site prior to the commencement of construction² and certify in this inspection report that the appropriate erosion and sediment controls described in the SWPPP have been adequately installed or implemented to ensure overall preparedness of the site for the commencement of construction.

Prior to the commencement of construction, the Operator shall certify in this site logbook that the SWPPP has been prepared in accordance with the State's standards and meets all Federal, State and local erosion and sediment control requirements.

When construction starts, site inspections shall be conducted by the qualified professional at least every 7 calendar days and within 24 hours of the end of a storm event of 0.5 inches or greater (Construction Duration Inspections). The Operator shall maintain a record of all inspection reports in this site logbook. The site logbook shall be maintained on site and be made available to the permitting authorities upon request. The Operator shall post at the site, in a publicly accessible location, a summary of the site inspection activities on a monthly basis (Monthly Summary Report).

The operator shall also prepare a written summary of compliance with this general permit at a minimum frequency of every three months (Operator's Compliance Response Form), while coverage exists. The summary should address the status of achieving each component of the SWPPP.

Prior to filing the Notice of Termination or the end of permit term, the Operator shall have a qualified professional perform a final site inspection. The qualified professional shall certify that the site has undergone final stabilization³ using either vegetative or structural stabilization methods and that all temporary erosion and sediment controls (such as silt fencing) not needed for long-term erosion control have been removed. In addition, the Operator must identify and certify that all permanent structures described in the SWPPP have been constructed and provide the owner(s) with an operation and maintenance plan that ensures the structure(s) continuously functions as designed.

1 "Qualified Professional means a person knowledgeable in the principles and practice of erosion and sediment controls, such as a Certified Professional in Erosion and Sediment Control (CPESC), soil scientist, licensed engineer or someone working under the direction and supervision of a licensed engineer (person must have experience in the principles and practices of erosion and sediment control).

2 "Commencement of construction" means the initial removal of vegetation and disturbance of soils associated with clearing, grading or excavating activities or other construction activities.

3 "Final stabilization" means that all soil-disturbing activities at the site have been completed and a uniform, perennial vegetative cover with a density of eighty (80) percent has been established or equivalent stabilization measures (such as the use of mulches or geotextiles) have been employed on all unpaved areas and areas not covered by permanent structures.

b. Operators Certification

"I certify under penalty of law that this document and all attachments were prepared under my direction or supervision in accordance with a system designed to assure that qualified personnel properly gathered and evaluated the information submitted. Based on my inquiry of the person or persons who manage the system, or those persons directly responsible for gathering the information, the information submitted is, to the best of my knowledge and belief, true, accurate, and complete. Further, I hereby certify that the SWPPP meets all Federal, State, and local erosion and sediment control requirements. I am aware that false statements made herein are punishable as a class A misdemeanor pursuant to Section 210.45 of the Penal Law.

Name (please print): _____

Title _____ Date: _____

Address: _____

Phone: _____ Email: _____

Signature: _____

c. Qualified Professional's Credentials & Certification

"I hereby certify that I meet the criteria set forth in the General Permit to conduct site inspections for this project and that the appropriate erosion and sediment controls described in the SWPPP and as described in the following Pre-construction Site Assessment Checklist have been adequately installed or implemented, ensuring the overall preparedness of this site for the commencement of construction."

Name (please print): _____

Title _____ Date: _____

Address: _____

Phone: _____ Email: _____

Signature: _____

d. Pre-construction Site Assessment Checklist

(NOTE: Provide comments below as necessary)

1. Notice of Intent, SWPPP, and Contractors Certification:

Yes No NA

- Has a Notice of Intent been filed with the NYS Department of Conservation?
- Is the SWPPP on-site? Where? _____
- Is the Plan current? What is the latest revision date? _____
- Is a copy of the NOI (with brief description) onsite? Where? _____
- Have all contractors involved with stormwater related activities signed a contractor's certification?

2. Resource Protection

Yes No NA

- Are construction limits clearly flagged or fenced?
- Important trees and associated rooting zones, on-site septic system absorption fields, existing vegetated areas suitable for filter strips, especially in perimeter areas, have been flagged for protection.
- Creek crossings installed prior to land-disturbing activity, including clearing and blasting.

3. Surface Water Protection

Yes No NA

- Clean stormwater runoff has been diverted from areas to be disturbed.
- Bodies of water located either on site or in the vicinity of the site have been identified and protected.
- Appropriate practices to protect on-site or downstream surface water are installed.
- Are clearing and grading operations divided into areas <5 acres?

4. Stabilized Construction Entrance

Yes No NA

- A temporary construction entrance to capture mud and debris from construction vehicles before they enter the public highway has been installed.
- Other access areas (entrances, construction routes, equipment parking areas) are stabilized immediately as work takes place with gravel or other cover.
- Sediment tracked onto public streets is removed or cleaned on a regular basis.

5. Perimeter Sediment Controls

Yes No NA

- Silt fence material and installation comply with the standard drawing and specifications.
- Silt fences are installed at appropriate spacing intervals
- Sediment/detention basin was installed as first land disturbing activity.
- Sediment traps and barriers are installed.

6. Pollution Prevention for Waste and Hazardous Materials

Yes No NA

- The Operator or designated representative has been assigned to implement the spill prevention avoidance and response plan.
- The plan is contained in the SWPPP on page _____
- Appropriate materials to control spills are onsite. Where? _____

II. CONSTRUCTION DURATION INSPECTIONS

a. Directions:

Inspection Forms will be filled out during the entire construction phase of the project.

Required Elements:

- (1) On a site map, indicate the extent of all disturbed site areas and drainage pathways. Indicate site areas that are expected to undergo initial disturbance or significant site work within the next 14-day period;
- (2) Indicate on a site map all areas of the site that have undergone temporary or permanent stabilization;
- (3) Indicate all disturbed site areas that have not undergone active site work during the previous 14-day period;
- (4) Inspect all sediment control practices and record the approximate degree of sediment accumulation as a percentage of sediment storage volume (for example, 10 percent, 20 percent, 50 percent);
- (5) Inspect all erosion and sediment control practices and record all maintenance requirements such as verifying the integrity of barrier or diversion systems (earthen berms or silt fencing) and containment systems (sediment basins and sediment traps). Identify any evidence of rill or gully erosion occurring on slopes and any loss of stabilizing vegetation or seeding/mulching. Document any excessive deposition of sediment or ponding water along barrier or diversion systems. Record the depth of sediment within containment structures, any erosion near outlet and overflow structures, and verify the ability of rock filters around perforated riser pipes to pass water; and
- (6) Immediately report to the Operator any deficiencies that are identified with the implementation of the SWPPP.

SITE PLAN/SKETCH

Inspector (print name)

Date of Inspection

Qualified Professional (print name)

Qualified Professional Signature

The above signed acknowledges that, to the best of his/her knowledge, all information provided on the forms is accurate and complete.

Maintaining Water Quality

Yes No NA

- Is there an increase in turbidity causing a substantial visible contrast to natural conditions?
- Is there residue from oil and floating substances, visible oil film, or globules or grease?
- All disturbance is within the limits of the approved plans.
- Have receiving lake/bay, stream, and/or wetland been impacted by silt from project?

Housekeeping

1. General Site Conditions

Yes No NA

- Is construction site litter and debris appropriately managed?
- Are facilities and equipment necessary for implementation of erosion and sediment control in working order and/or properly maintained?
- Is construction impacting the adjacent property?
- Is dust adequately controlled?

2. Temporary Stream Crossing

Yes No NA

- Maximum diameter pipes necessary to span creek without dredging are installed.
- Installed non-woven geotextile fabric beneath approaches.
- Is fill composed of aggregate (no earth or soil)?
- Rock on approaches is clean enough to remove mud from vehicles & prevent sediment from entering stream during high flow.

Runoff Control Practices

1. Excavation Dewatering

Yes No NA

- Upstream and downstream berms (sandbags, inflatable dams, etc.) are installed per plan.
- Clean water from upstream pool is being pumped to the downstream pool.
- Sediment laden water from work area is being discharged to a silt-trapping device.
- Constructed upstream berm with one-foot minimum freeboard.

2. Level Spreader

Yes No NA

- Installed per plan.
- Constructed on undisturbed soil, not on fill, receiving only clear, non-sediment laden flow.
- Flow sheets out of level spreader without erosion on downstream edge.

3. Interceptor Dikes and Swales

Yes No NA

- Installed per plan with minimum side slopes 2H:1V or flatter.
- Stabilized by geotextile fabric, seed, or mulch with no erosion occurring.
- Sediment-laden runoff directed to sediment trapping structure

Runoff Control Practices (continued)

4. Stone Check Dam

Yes No NA

- Is channel stable? (flow is not eroding soil underneath or around the structure).
- Check is in good condition (rocks in place and no permanent pools behind the structure).
- Has accumulated sediment been removed?.

5. Rock Outlet Protection

Yes No NA

- Installed per plan.
- Installed concurrently with pipe installation.

Soil Stabilization

1. Topsoil and Spoil Stockpiles

Yes No NA

- Stockpiles are stabilized with vegetation and/or mulch.
- Sediment control is installed at the toe of the slope.

2. Revegetation

Yes No NA

- Temporary seedings and mulch have been applied to idle areas.
- 4 inches minimum of topsoil has been applied under permanent seedings

Sediment Control Practices

1. Stabilized Construction Entrance

Yes No NA

- Stone is clean enough to effectively remove mud from vehicles.
- Installed per standards and specifications?
- Does all traffic use the stabilized entrance to enter and leave site?
- Is adequate drainage provided to prevent ponding at entrance?

2. Silt Fence

Yes No NA

- Installed on Contour, 10 feet from toe of slope (not across conveyance channels).
 - Joints constructed by wrapping the two ends together for continuous support.
 - Fabric buried 6 inches minimum.
 - Posts are stable, fabric is tight and without rips or frayed areas.
- Sediment accumulation is ___% of design capacity.

Sediment Control Practices (continued)

3. Storm Drain Inlet Protection (Use for Stone & Block; Filter Fabric; Curb; or, Excavated practices)

Yes No NA

- Installed concrete blocks lengthwise so open ends face outward, not upward.
 - Placed wire screen between No. 3 crushed stone and concrete blocks.
 - Drainage area is 1acre or less.
 - Excavated area is 900 cubic feet.
 - Excavated side slopes should be 2:1.
 - 2" x 4" frame is constructed and structurally sound.
 - Posts 3-foot maximum spacing between posts.
 - Fabric is embedded 1 to 1.5 feet below ground and secured to frame/posts with staples at max 8-inch spacing.
 - Posts are stable, fabric is tight and without rips or frayed areas.
- Sediment accumulation ___% of design capacity.

4. Temporary Sediment Trap

Yes No NA

- Outlet structure is constructed per the approved plan or drawing.
 - Geotextile fabric has been placed beneath rock fill.
- Sediment accumulation is ___% of design capacity.

5. Temporary Sediment Basin

Yes No NA

- Basin and outlet structure constructed per the approved plan.
 - Basin side slopes are stabilized with seed/mulch.
 - Drainage structure flushed and basin surface restored upon removal of sediment basin facility.
- Sediment accumulation is ___% of design capacity.

Note: Not all erosion and sediment control practices are included in this listing. Add additional pages to this list as required by site specific design.
 Construction inspection checklists for post-development stormwater management practices can be found in Appendix F of the New York Stormwater Management Design Manual.

Contractor/Subcontractor Certification Statement

Site Name: _____

Site Address: _____

In accordance with Part III.A.6 of the General Permit GP-0-10-001, all contractors and subcontractors identified in the SWPPP shall sign a copy of the following certification statement before undertaking any construction activity at the site identified in the SWPPP.

"I hereby certify that I understand and agree to comply with the terms and conditions of the SWPPP and agree to implement any corrective actions identified by the qualified inspector during a site inspection. I also understand that the owner or operator must comply with the terms and conditions of the most current version of the New York State Pollutant Discharge Elimination System ("SPDES") general permit for stormwater discharges from construction activities and that it is unlawful for any person to cause or contribute to a violation of water quality standards. Furthermore, I understand that certifying false, incorrect or inaccurate information is a violation of the referenced permit and the laws of the State of New York and could subject me to criminal, civil and/or administrative proceedings."

Contractor Name: _____

Contractor Address: _____

Contractor Phone Number: _____

Name (please print): _____ **Title:** _____

Signature: _____ **Date:** _____

Contractor/Subcontractor SWPPP Responsibilities

The above reference contractor/subcontractor is responsible for the following elements of the SWPPP:

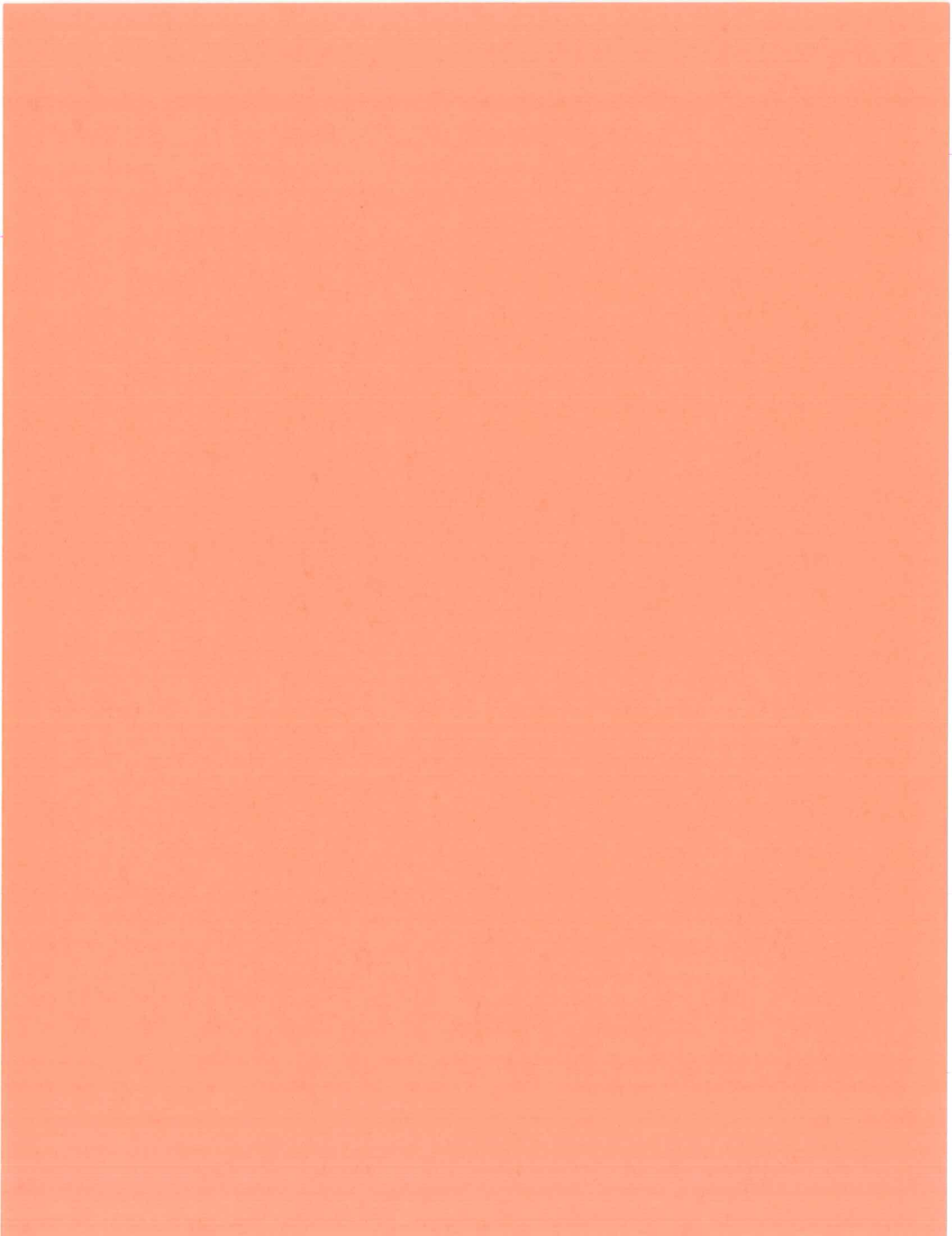

APPENDIX I

PIPE SIZING ANALYSIS

Scenario: 25-Year

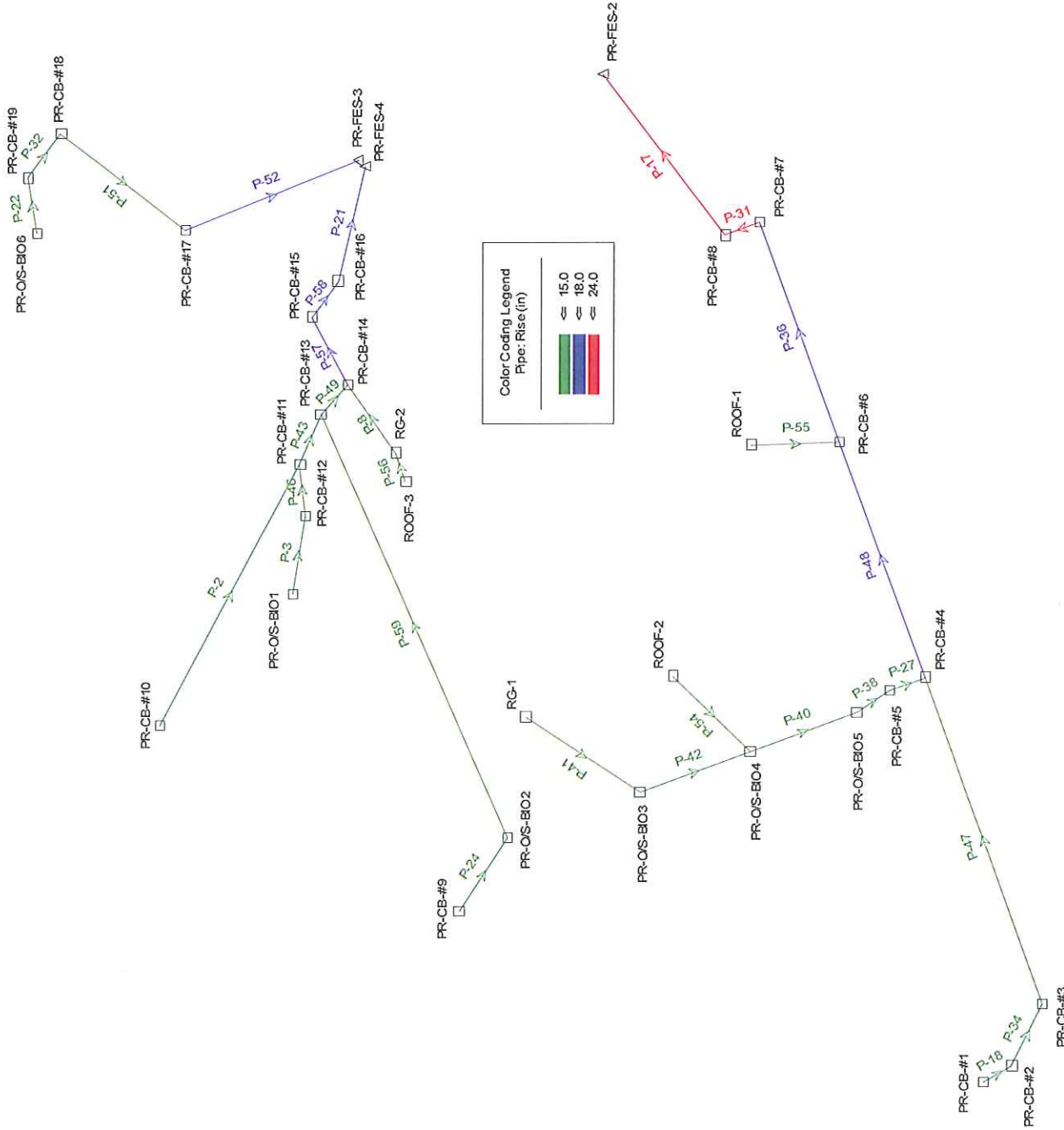

Color Coding Legend	
Pipe: Rise (in)	
Green	≤ 15.0
Blue	≤ 18.0
Red	≤ 24.0

Scenario: 25-Year

Inlet Report

Label	Calculated Station (ft)	Ground Elevation (ft)	Rim Elevation (ft)	Sump Elevation (ft)	Desired Sump Depth (ft)	Invert Out Elevation (ft)	Area (ft ²)	Inlet C	Inlet CA (ft ²)	Time of Concentration (min)	System Rational Flow (cfs)	Inlet Type
PR-CB-#1	6+95	360.71	360.71	354.97	1.33	356.30	13,569	0.44	5,963	7.74	0.93	Combination Inlet
PR-CB-#2	6+77	361.50	361.50	354.79	1.33	356.12	4,951	0.91	4,486	3.75	1.63	Grate Inlet
PR-CB-#3	6+37	360.69	360.69	354.39	1.33	355.72	3,638	0.90	3,270	4.21	2.13	Combination Inlet
PR-CB-#4	4+30	355.41	355.41	349.26	1.33	350.59	11,314	0.93	10,466	4.56	9.59	Grate Inlet
PR-CB-#5	4+51	355.29	355.29	349.72	1.33	351.05	2,044	0.85	1,746	5.66	6.92	Grate Inlet
PR-CB-#6	2+81	356.76	356.76	347.77	1.33	349.10	1,707	0.88	1,510	6.24	10.47	Grate Inlet
PR-CB-#7	1+42	355.53	355.53	345.88	1.33	347.21	11,129	0.83	9,241	6.42	11.40	Grate Inlet
PR-CB-#8	1+22	355.69	355.69	345.68	1.33	347.01	1,056	0.86	905	6.42	11.40	Grate Inlet
PR-CB-#9	4+91	357.77	357.77	351.86	1.33	353.19	12,068	0.66	7,956	7.47	1.26	Combination Inlet
PR-CB-#10	3+68	355.37	355.37	349.67	1.33	351.00	11,020	0.64	7,065	9.54	1.02	Combination Inlet
PR-CB-#11	1+91	353.65	353.65	347.57	1.33	348.90	13,138	0.56	7,420	10.78	4.10	Grate Inlet
PR-CB-#12	2+21	353.78	353.78	348.14	1.33	349.47	2,273	0.87	1,974	3.24	2.41	Grate Inlet
PR-CB-#13	1+61	353.43	353.43	347.27	1.33	348.60	2,917	0.60	1,763	5.09	6.03	Combination Inlet
PR-CB-#14	1+38	353.07	353.07	347.04	1.33	348.37	7,941	0.75	5,977	6.08	7.92	Combination Inlet
PR-CB-#15	0+94	353.39	353.39	346.60	1.33	347.93	547	0.95	520	3.32	7.97	Combination Inlet
PR-CB-#16	0+70	353.55	353.55	346.36	1.33	347.69	23,947	0.89	21,222	11.32	10.42	Combination Inlet
PR-CB-#17	1+14	350.71	350.71	340.98	1.33	342.31	1,733	0.63	1,094	7.39	6.78	Combination Inlet
PR-CB-#18	2+07	346.72	346.72	342.16	1.33	343.49	4,707	0.78	3,658	3.75	6.68	Combination Inlet
PR-CB-#19	2+39	347.22	347.22	342.48	1.33	343.81	6,172	0.55	3,391	5.25	6.18	Combination Inlet
PR-O/S-BIC	2+68	353.44	353.44	348.61	1.33	349.94	24,163	0.77	18,591	15.46	2.19	Grate Inlet
PR-O/S-BIC	4+41	355.69	355.69	350.86	1.33	352.19	8,780	0.79	6,933	6.27	2.34	Grate Inlet
PR-O/S-BIC	6+13	356.44	356.44	351.61	1.33	352.94	10,124	0.76	7,663	12.95	1.01	Grate Inlet
PR-O/S-BIC	5+43	355.44	355.44	350.64	1.33	351.97	17,967	0.82	14,660	15.90	4.39	Grate Inlet
PR-O/S-BIC	4+73	354.77	354.77	349.94	1.33	351.27	26,120	0.87	22,785	17.91	6.73	Grate Inlet
PR-O/S-BIC	2+73	352.00	352.00	347.17	1.33	348.50	52,427	0.77	40,508	10.00	5.71	Grate Inlet
RG-1	6+97	356.00	356.00	352.17	1.33	353.50	872	0.25	218	1.00	0.04	Grate Inlet
RG-2	1+86	356.00	356.00	352.17	1.33	353.50	1,048	0.25	262	1.00	1.81	Grate Inlet
ROOF-1	3+35	358.44	358.44	354.44	0.00	354.44	7,500	0.95	7,125	2.00	1.25	Generic Inlet
ROOF-2	6+09	358.44	358.44	354.44	0.00	354.44	16,000	0.95	15,200	2.00	2.67	Generic Inlet
ROOF-3	2+05	358.44	358.44	354.44	0.00	354.44	10,600	0.95	10,070	2.00	1.77	Generic Inlet

Scenario: 25-Year

Pipe Report

Label	Upstream Node	Downstream Node	Upstream Invert Elevation (ft)	Downstream Invert Elevation (ft)	Section Size	Length (ft)	Material	Constructed Slope (ft/ft)	Mannings n	Total System Flow (cfs)	Full Capacity (cfs)	Hydraulic Grade Line In (ft)	Hydraulic Grade Line Out (ft)
P-18	PR-CB#1	PR-CB#2	356.30	356.12	15 inch	18.00	Corrugated HDPE (Smooth Interior)	0.010000	0.012	0.93	7.00	356.68	356.63
P-34	PR-CB#2	PR-CB#3	356.12	355.72	15 inch	40.00	Corrugated HDPE (Smooth Interior)	0.010000	0.012	1.63	7.00	356.63	356.30
P-47	PR-CB#3	PR-CB#4	355.72	350.84	15 inch	207.00	Corrugated HDPE (Smooth Interior)	0.023575	0.012	2.13	10.74	356.30	351.79
P-48	PR-CB#4	PR-CB#6	350.59	349.10	18 inch	149.00	Corrugated HDPE (Smooth Interior)	0.010000	0.012	9.59	11.38	351.79	350.34
P-27	PR-CB#5	PR-CB#4	351.05	350.59	15 inch	21.00	Corrugated HDPE (Smooth Interior)	0.021905	0.012	6.92	10.36	352.10	351.79
P-36	PR-CB#6	PR-CB#7	349.10	347.71	18 inch	139.00	Corrugated HDPE (Smooth Interior)	0.010000	0.012	10.47	11.38	350.34	348.84
P-31	PR-CB#7	PR-CB#8	347.21	347.01	24 inch	20.00	Corrugated HDPE (Smooth Interior)	0.010000	0.012	11.40	24.51	348.42	348.23
P-17	PR-CB#8	PR-FES-2	347.01	342.00	24 inch	122.00	Corrugated HDPE (Smooth Interior)	0.041066	0.012	11.49	49.66	348.23	342.65
P-24	PR-CB#9	PR-O/S-BIO2	353.19	352.19	15 inch	50.00	Corrugated HDPE (Smooth Interior)	0.020000	0.012	1.26	9.90	353.63	352.80
P-2	PR-CB#10	PR-CB#11	351.00	349.17	15 inch	177.00	Corrugated HDPE (Smooth Interior)	0.010339	0.012	1.02	7.12	351.40	349.72
P-43	PR-CB#11	PR-CB#13	348.90	348.60	15 inch	30.00	Corrugated HDPE (Smooth Interior)	0.010000	0.012	4.10	7.00	349.72	349.59
P-46	PR-CB#12	PR-CB#11	349.47	349.17	15 inch	30.00	Corrugated HDPE (Smooth Interior)	0.010000	0.012	2.41	7.00	350.09	349.68
P-49	PR-CB#13	PR-CB#14	348.60	348.37	15 inch	23.00	Corrugated HDPE (Smooth Interior)	0.010000	0.012	6.03	7.00	349.59	349.46
P-57	PR-CB#14	PR-CB#15	348.37	347.93	18 inch	44.00	Corrugated HDPE (Smooth Interior)	0.010000	0.012	7.92	11.38	349.46	349.02
P-58	PR-CB#15	PR-CB#16	347.93	347.69	18 inch	24.00	Corrugated HDPE (Smooth Interior)	0.010000	0.012	7.97	11.38	349.02	348.93
P-21	PR-CB#16	PR-FES-4	347.69	342.00	18 inch	70.00	Corrugated HDPE (Smooth Interior)	0.081286	0.012	10.42	32.44	348.93	342.60
P-52	PR-CB#17	PR-FES-3	342.31	341.74	18 inch	114.00	Corrugated HDPE (Smooth Interior)	0.005000	0.012	6.78	8.05	343.37	342.75
P-51	PR-CB#18	PR-CB#17	343.49	342.56	15 inch	93.00	Corrugated HDPE (Smooth Interior)	0.010000	0.012	6.68	7.00	344.53	343.54
P-32	PR-CB#19	PR-CB#18	343.81	343.49	15 inch	32.00	Corrugated HDPE (Smooth Interior)	0.010000	0.012	6.18	7.00	344.81	344.53
P-3	PR-O/S-BIO1	PR-CB#12	349.94	349.47	15 inch	47.00	Corrugated HDPE (Smooth Interior)	0.010000	0.012	2.19	7.00	350.53	350.09
P-59	PR-O/S-BIO2	PR-CB#13	352.19	348.85	15 inch	280.00	Corrugated HDPE (Smooth Interior)	0.011929	0.012	2.34	7.64	352.80	349.59
P-42	PR-O/S-BIO3	PR-O/S-BIO4	352.94	351.97	15 inch	70.00	Corrugated HDPE (Smooth Interior)	0.013857	0.012	1.01	8.24	353.33	352.82
P-40	PR-O/S-BIO4	PR-O/S-BIO5	351.97	351.27	15 inch	70.00	Corrugated HDPE (Smooth Interior)	0.010000	0.012	4.39	7.00	352.82	352.31
P-38	PR-O/S-BIO5	PR-CB#5	351.27	351.05	15 inch	22.00	Corrugated HDPE (Smooth Interior)	0.010000	0.012	6.73	7.00	352.31	352.10
P-22	PR-O/S-BIO6	PR-CB#19	348.50	343.81	15 inch	34.00	Corrugated HDPE (Smooth Interior)	0.137941	0.012	5.71	25.99	349.47	344.81
P-41	RG-1	PR-O/S-BIO3	353.50	352.94	15 inch	84.00	Corrugated HDPE (Smooth Interior)	0.006667	0.012	0.04	5.71	353.57	353.33
P-8	RG-2	PR-CB#14	353.50	348.62	15 inch	48.00	Corrugated HDPE (Smooth Interior)	0.101667	0.012	1.81	22.31	354.03	349.46
P-55	ROOF-1	PR-CB#6	354.44	349.93	8 inch	54.00	Corrugated HDPE (Smooth Interior)	0.083519	0.012	1.25	3.78	354.97	350.19
P-54	ROOF-2	PR-O/S-BIO4	354.44	352.55	10 inch	66.00	Corrugated HDPE (Smooth Interior)	0.028636	0.012	2.67	4.02	355.16	353.05
P-56	ROOF-3	RG-2	354.44	353.50	15 inch	19.00	Corrugated HDPE (Smooth Interior)	0.049474	0.012	1.77	15.56	354.97	354.03

Profile Scenario: 25-Year

Profile: PR-CB-#1 to PR-FES-2

Scenario: 25-Year

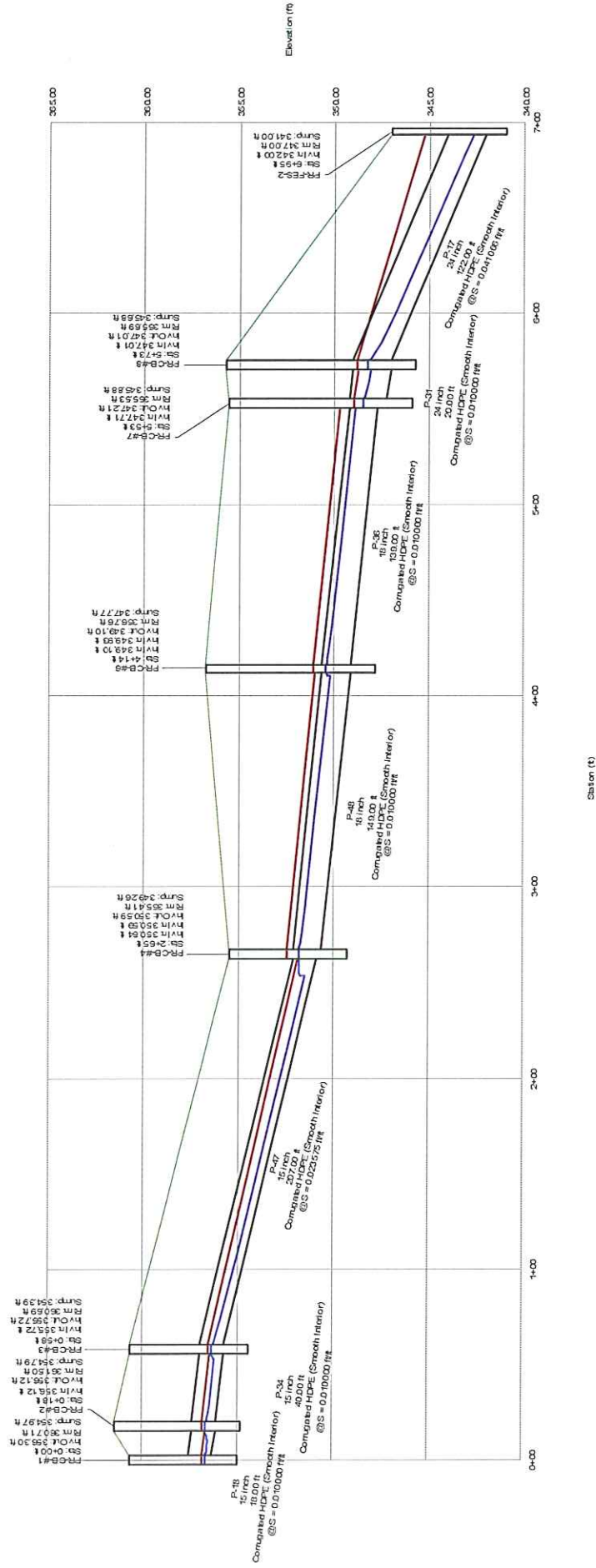

Profile Scenario: 25-Year

Profile: RG-1 to PR-CB-#4

Scenario: 25-Year

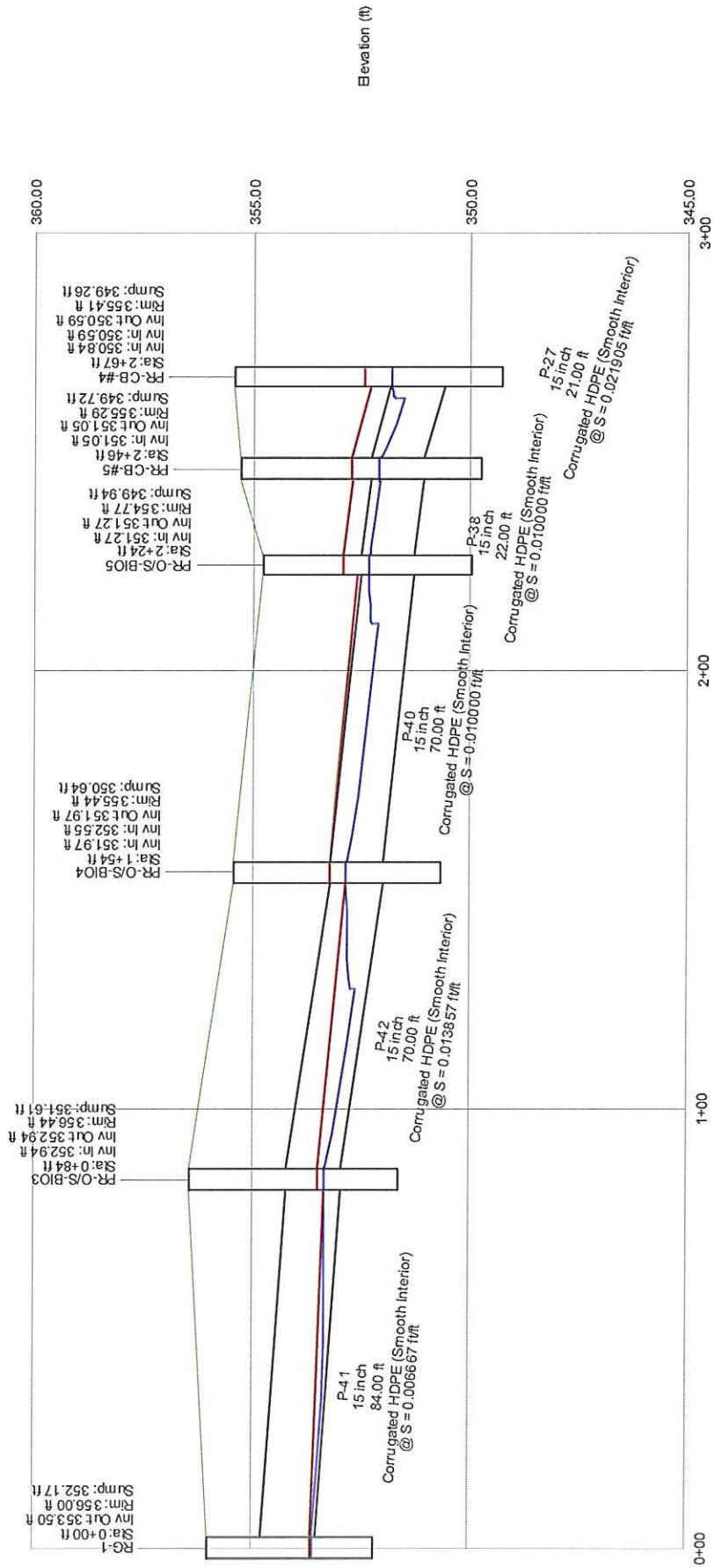

Profile Scenario: 25-Year

Profile: PR-CB-#9 to PR-FES-4

Scenario: 25-Year

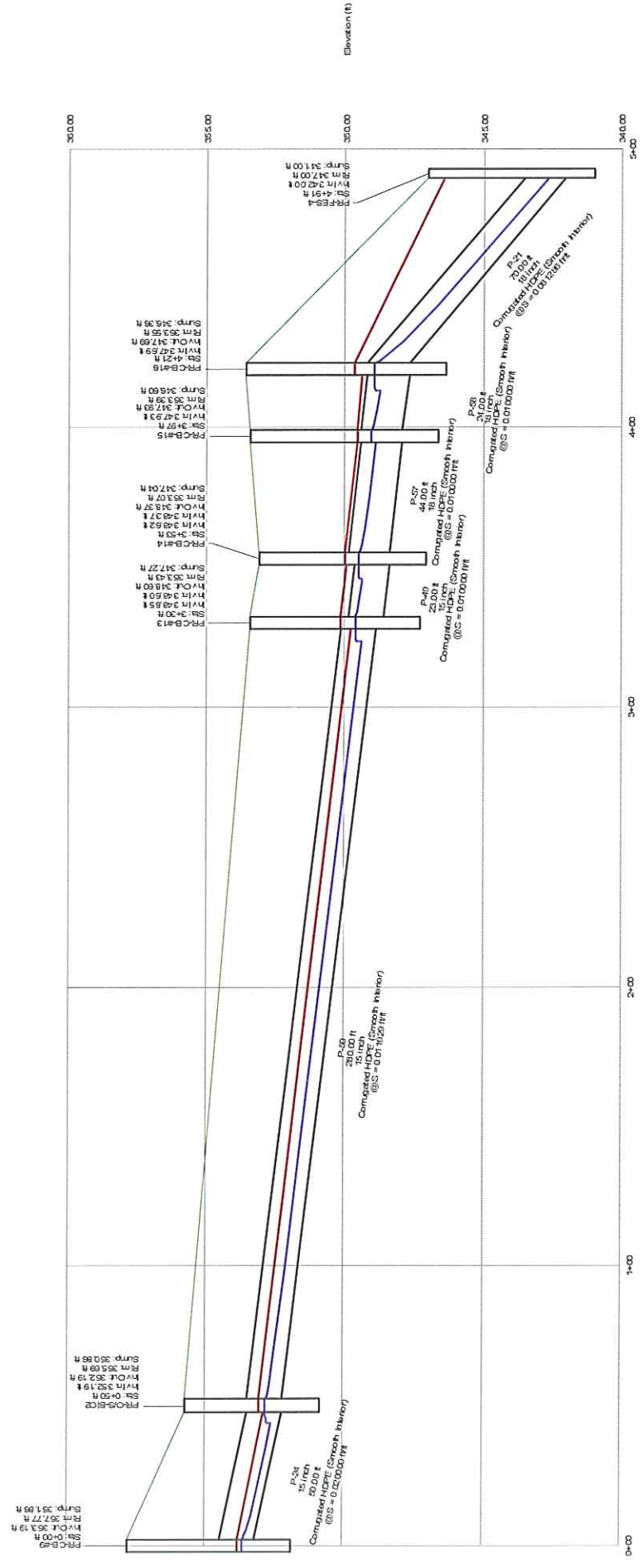

Profile

Scenario: 25-Year

Profile: PR-O/S-BIO6 to PR-FES-3

Scenario: 25-Year

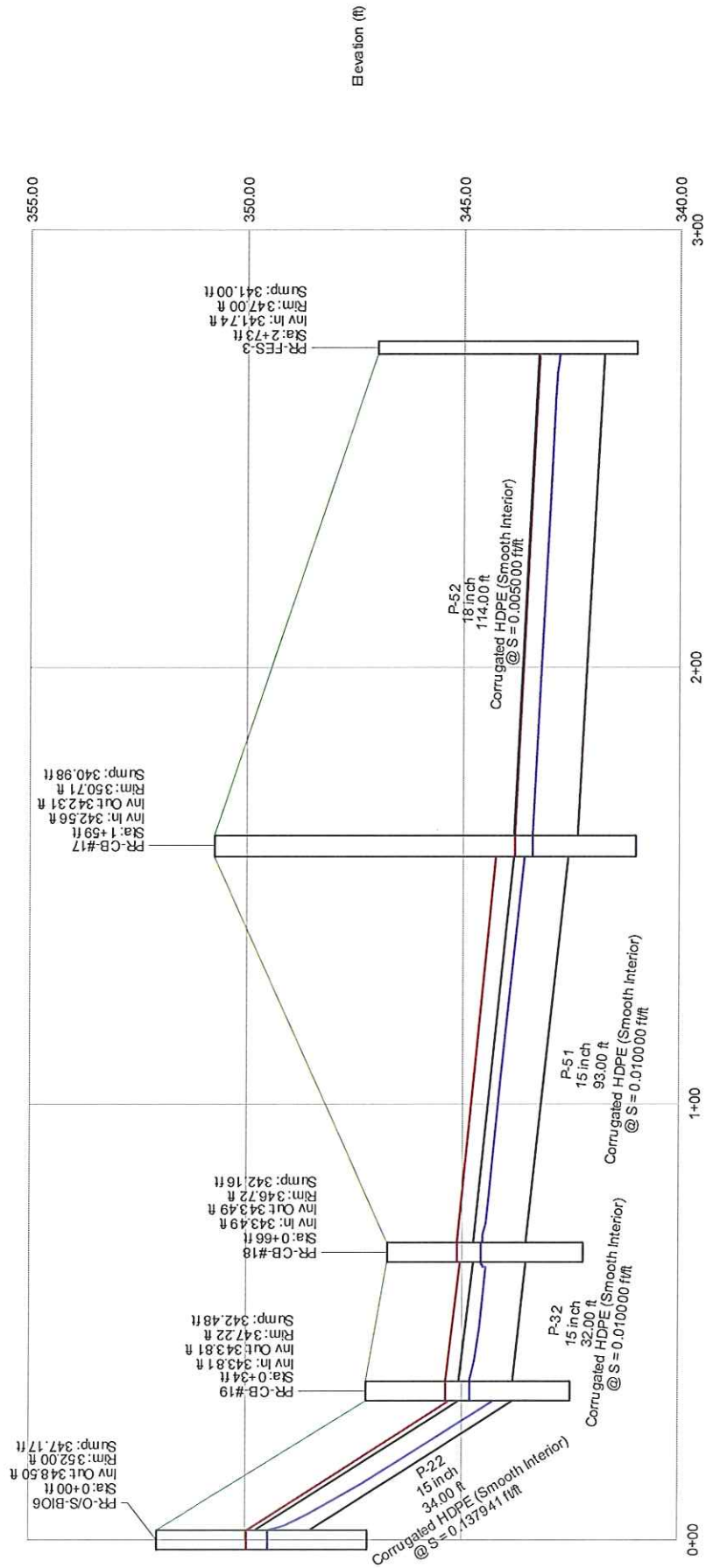

Profile
Scenario: 25-Year

Profile: ROOF-1 to PR-CB-#6

Scenario: 25-Year

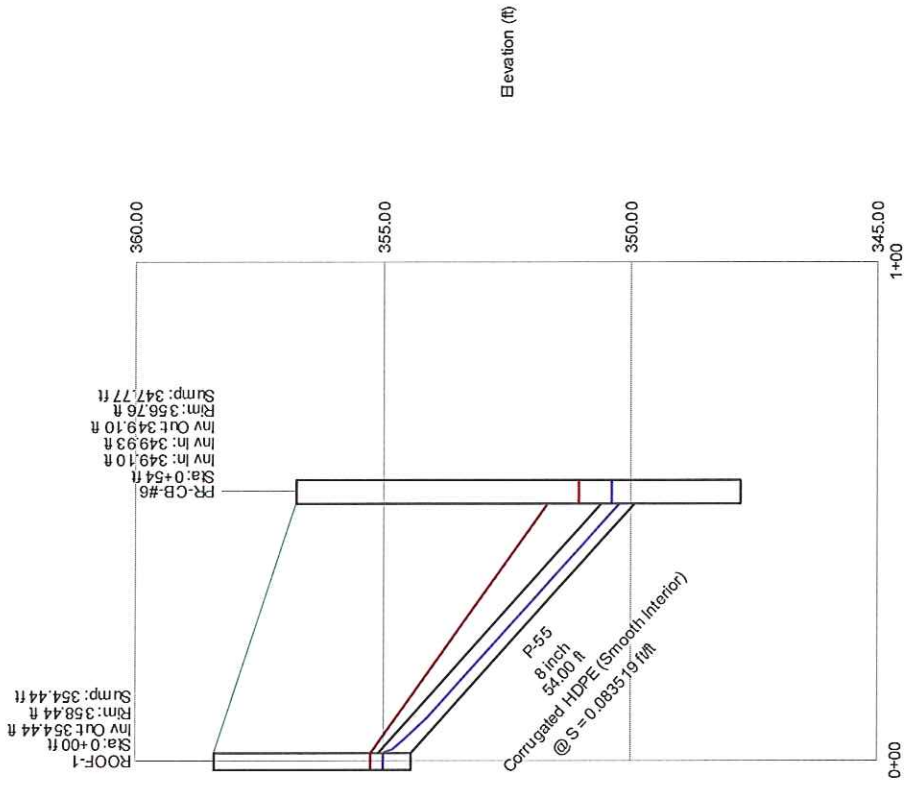

Station (ft)
Lanc & Tully Engineering and Surveying, P.C.
37 Brookside Road Waterbury, CT 06708 USA +1-203-755-1666

Profile
Scenario: 25-Year

Profile: ROOF-2 to PR-O/S-BIO4

Scenario: 25-Year

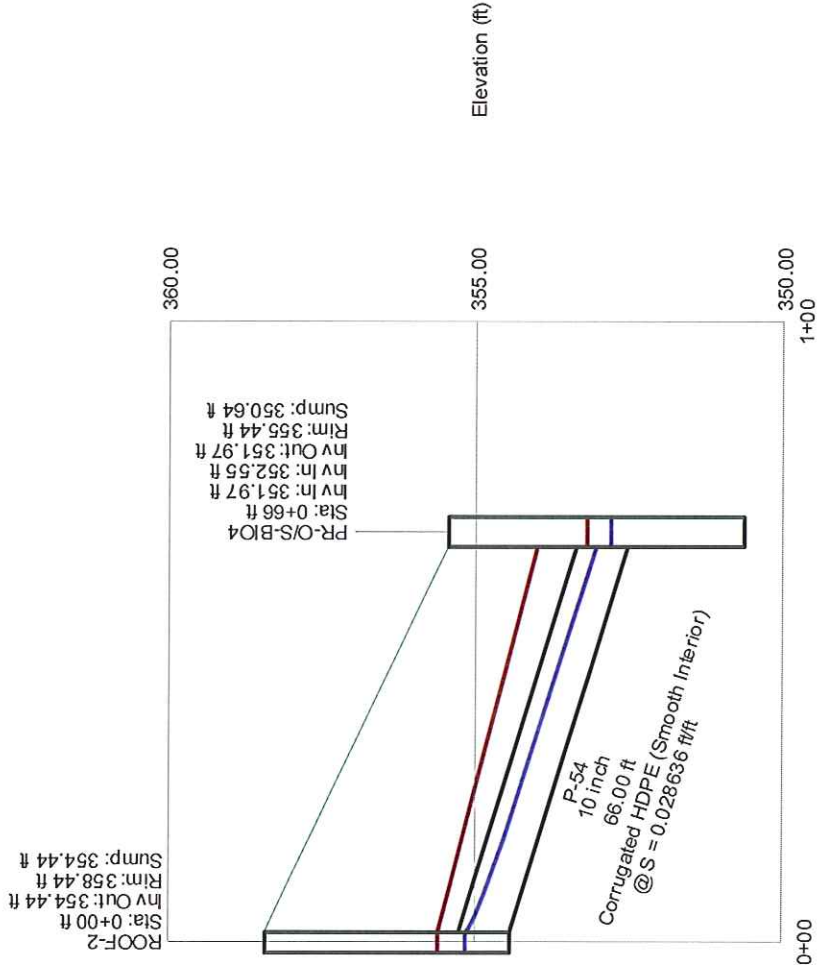

Profile
Scenario: 25-Year

Profile: ROOF-3 to PR-CB-#12

Scenario: 25-Year

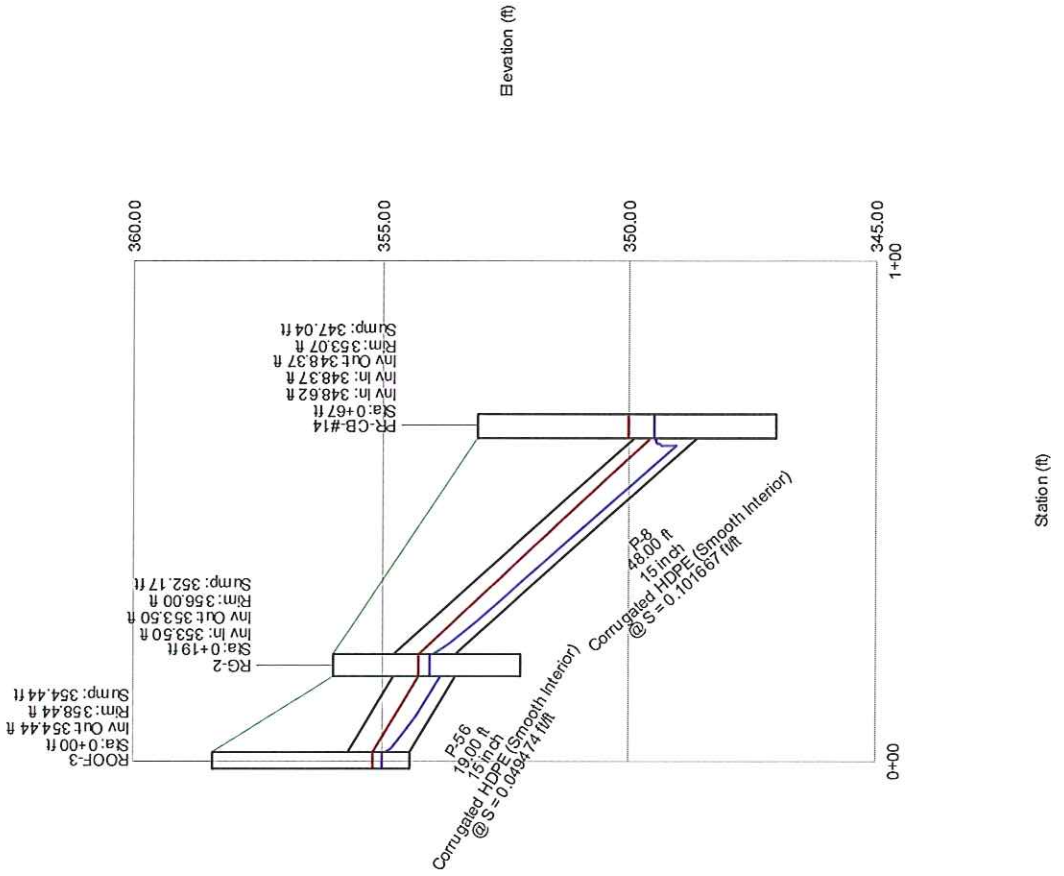

CRH REALTY VIII, LLC / BRITAIN PLAZA
Town of Newburgh, New York

Time of Concentration/ Rainfall Intensity Calculation

Area/Structure	Time of Concentration				Tc (min)	Description
	Unpaved (ft)	(%)	Paved Segment, (ft)	(%)		
PR-CB-1	76	10.5	53	1.7	7.74	
PR-CB-2	1	1.0	186	4.6	3.75	
PR-CB-3	1	1.0	239	3.8	4.21	
PR-CB-4	1	1.0	219	2.3	4.56	
PR-CB-5	9	2.0	116	3.0	5.66	
PR-CB-6	18	2.0	37	3.5	6.24	
PR-CB-7	9	2.0	145	1.6	6.42	
PR-CB-8	6	2.0	42	3.2	4.16	
PR-CB-9	47	17.0	233	1.8	7.47	
PR-CB-10	50	6.0	188	1.1	9.54	
PR-CB-11	71	5.6	158	0.9	10.78	
PR-CB-12	5	6.1	57	3.3	3.24	
PR-CB-13	21	13.5	63	1.0	5.09	
PR-CB-14	36	7.2	56	3.6	6.08	
PR-CB-15	1	1.0	41	0.9	3.32	
PR-CB-16	30	1.0	206	2.3	11.32	
PR-CB-17	16	1.0	60	4.5	7.39	
PR-CB-18	14	21.4	91	3.6	3.75	
PR-CB-19	22	13.6	161	3.6	5.25	
PR-O/S-BIO1	109	1.7	106	2.4	15.46	
PR-O/S-BIO2	31	6.0	93	4.5	6.27	
PR-O/S-BIO3	139	3.8	43	2.1	12.95	
PR-O/S-BIO4	206	3.1	16	2.2	15.90	
PR-O/S-BIO5	220	2.3	17	3.8	17.91	
PR-O/S-BIO6					10.00	
RG-1					1.00	
RG-2					1.00	
ROOF-1					2.00	
ROOF-2					2.00	
ROOF-3					2.00	

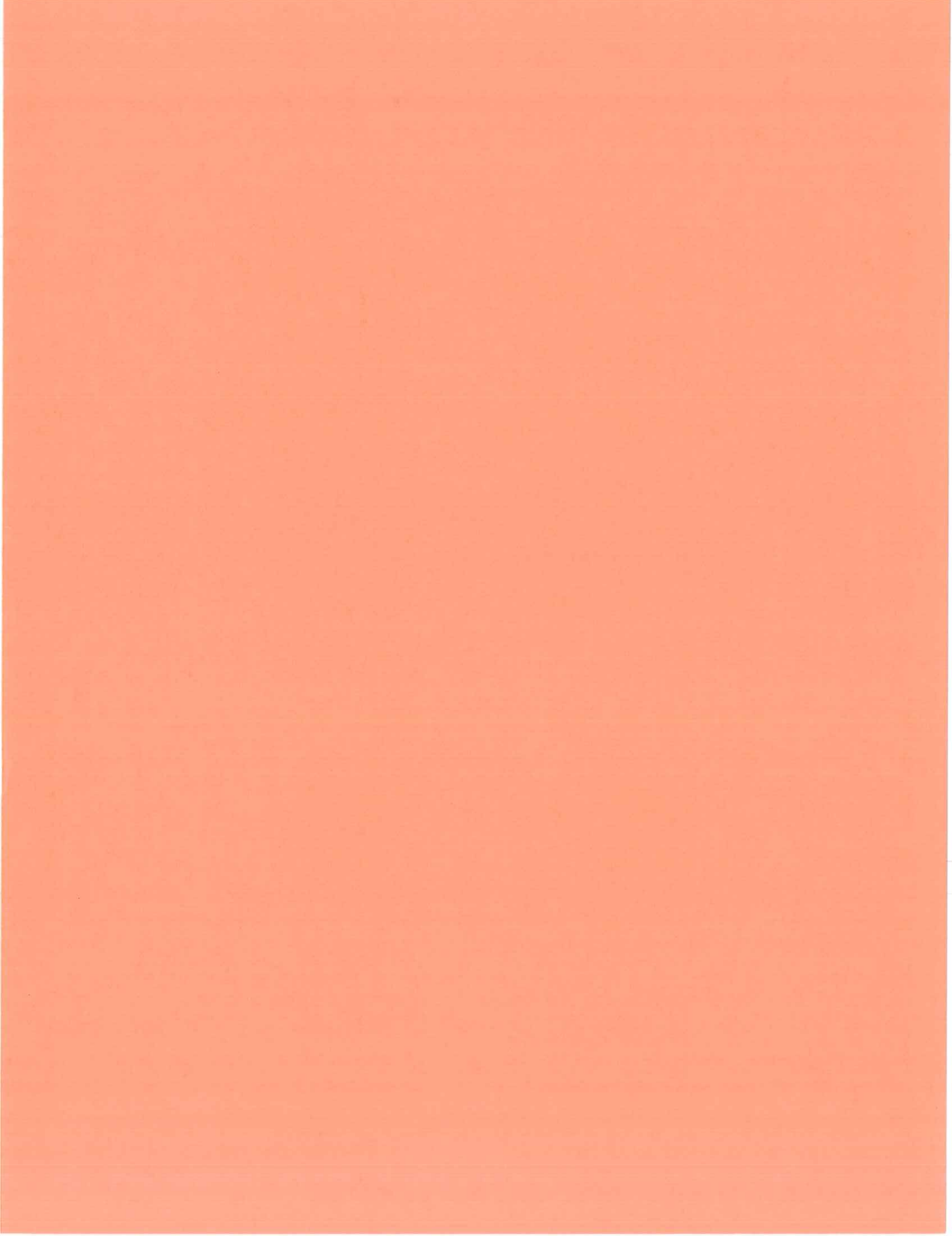

APPENDIX J

TEST PIT INFORMATION



KEY:



NUMBER AND APPROXIMATE LOCATION OF TEST PITS PERFORMED FOR THIS STUDY

NOTES:

1. This drawing is part of Melick-Tully and Associates, P.C. Report No. 9157-001*1D and should be read together with the report for complete evaluation.
2. General layout was obtained from a drawing prepared by Lane & Tully Eng., entitled "Lot Line Change" & Consolidation Map Prepared for CRH Realty VIII, dated 9/17-13, scale 1"=50'.

PLOT PLAN

PROPOSED MEDICAL OFFICE BUILDING
NEWBURGH, NEW YORK
CRH REALTY VIII, LLC



MELICK-TULLY AND ASSOCIATES, P.C.
Civil, Mechanical, Electrical
& Environmental Engineers
117 Grand Street
South Bound Brook, New Jersey 08840
(973) 356-3400

JOB NO. 9157-001*1D

FILE NO. 26143

DATE: 1-26-14

SCALE: 1"=100'

PLATE 2

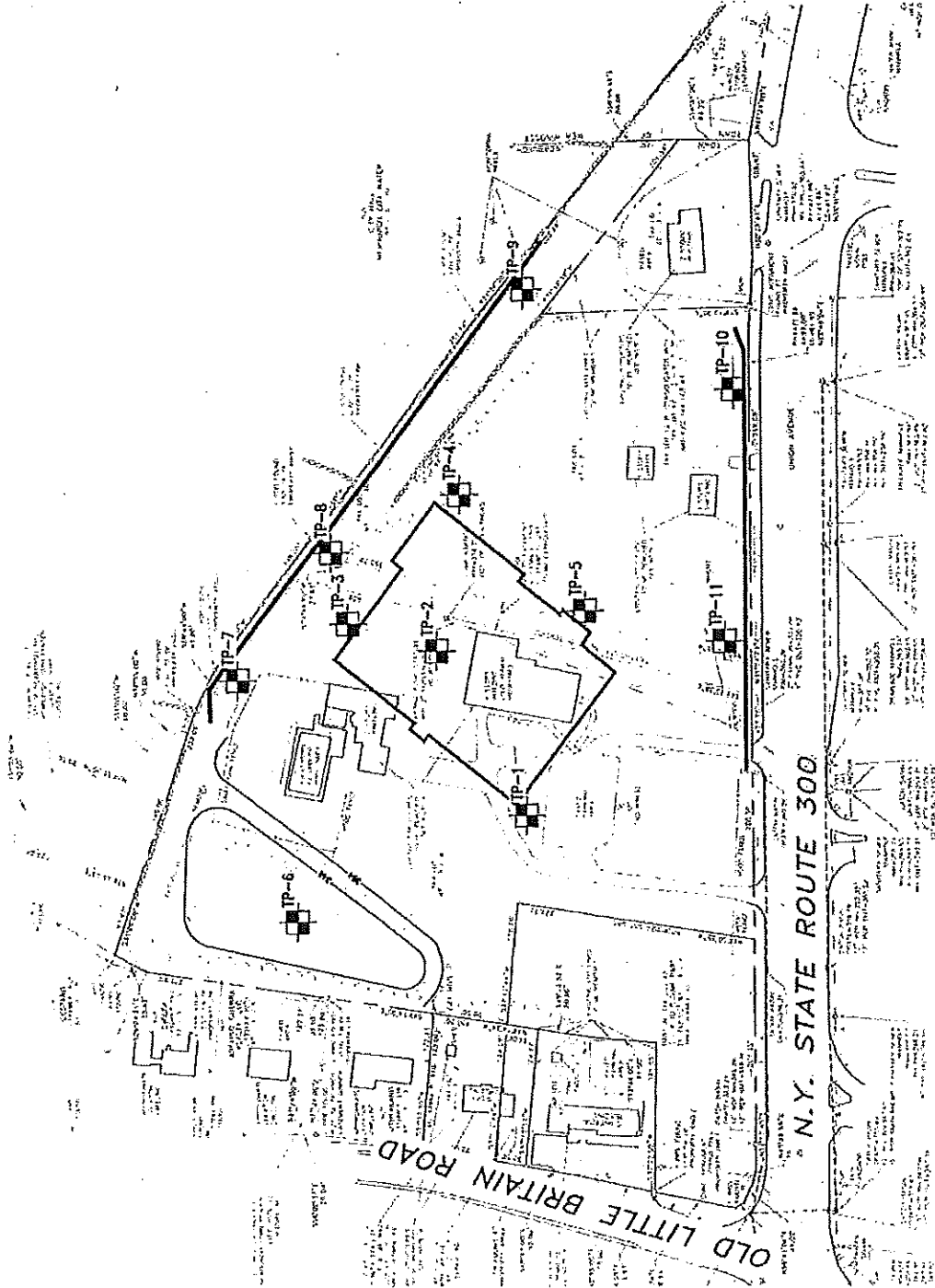

LOG OF TEST PIT

TEST PIT NO: 6

COMPLETION DATE: 1/14/14
JOB NUMBER: 9157-001*1D

SURFACE ELEVATION: +347 ft (±)

WATER LEVEL: *
READING DATE: 1/14/14

DEPTH	SAMPLES (1)	MOISTURE CONTENT (%)	SYMBOL	DESCRIPTION	DEPTH
				12" Topsoil	
	S1	21.0	SM	Brown fine to coarse sand, and clayey silt, some fine to coarse sand, little fine gravel (moist)(medium dense)	
5	S2	12.8		Brown fine to coarse sand, some fine to coarse gravel, and silt, occasional cobbles and boulders (moist)(medium dense to dense)	5
	S3		SM		
10					10
	S4				
15					15
				Test pit completed @ 15'	
				Mottling observed @ 5'	
				*Groundwater seepage not encountered	
20					20

NOTES FOR COLUMNS:
1. SAMPLE AT AVERAGE SAMPLING DEPTH

SOIL DESCRIPTION MODIFIERS:
TRACE 0 - 10%
LITTLE 10 - 20%
SOME 20 - 35%
AND OVER 35%

Typist/Date: jhb/mh 1/14

Sheet: 1 of 1 PLATE: 3F

MAJOR DIVISIONS			LETTER SYMBOL	TYPICAL DESCRIPTIONS
COARSE GRAINED SOILS More than 50% of material is LARGER than No. 200 Sieve	GRAVEL & GRAVELLY SOILS More than 50% of coarse fraction RETAINED on No. 4 Sieve	CLEAN GRAVELS (Little or no fines)	GW	Well-graded gravels, gravel-sand mixtures, little or no fines.
		GRAVELS WITH FINES (Appreciable amount of fines)	GP	Poorly-graded gravels, gravel-sand mixtures, little or no fines.
			GM	Silty gravels, gravel-sand-silt mixtures.
		SAND AND SANDY SOILS More than 50% of coarse fraction PASSING a No. 4 Sieve	CLEAN SAND (Little or no fines)	GC
	SW			Well-graded sands, gravelly sands, little or no fines.
	SANDS WITH FINES (Appreciable amount of fines)		SP	Poorly-graded sands, gravelly sands, little or no fines.
			SM	Silty sands, sand-silt mixtures
	FINE GRAINED SOILS More than 50% of material is SMALLER than No. 200 Sieve.	SILTS AND CLAYS Liquid limit LESS than 50	SC	Clayey sands, sand-clay mixtures.
ML			Inorganic silts and very fine sands, rock flour, silty or clayey fine sands or clayey silts with slight plasticity.	
CL			Inorganic clays of low to medium plasticity, gravelly clays, sandy clays, silty clays, lean clays.	
SILTS AND CLAYS Liquid limit GREATER than 50		OL	Organic silts and organic silty clays of low plasticity.	
		MH	Inorganic silts, micaceous or diatomaceous fine sand or silty soils.	
		CH	Inorganic clays of high plasticity, fat clays.	
		OH	Organic clays of medium to high plasticity, organic silts.	
HIGHLY ORGANIC SOILS			PT	Peat, humus, swamp soils with high organic contents

NOTE: DUAL SYMBOLS ARE USED TO INDICATE BORDERLINE SOIL CLASSIFICATIONS.

GRADATION*		COMPACTNESS*		CONSISTENCY*	
		sand and/or gravel		clay and/or silt	
% Finer by Weight		Relative Density		Range of Shearing Strength in Pounds per Square Foot	
Trace	0% to 10%	Loose	0% to 40%	Very Soft	less than 250
Little	10% to 20%	Medium Dense	40% to 70%	Soft	250 to 500
Some	20% to 35%	Dense	70% to 90%	Medium	500 to 1000
And	35% to 50%	Very Dense	90% to 100%	Stiff	1000 to 2000
				Very Stiff	2000 to 4000
				Hard	Greater than 4000

*Values are from laboratory or field test data, where applicable. When no testing was performed, values are estimated.

UNIFIED SOIL CLASSIFICATION SYSTEM

SOIL CLASSIFICATION CHART

Gradation Curve(s)

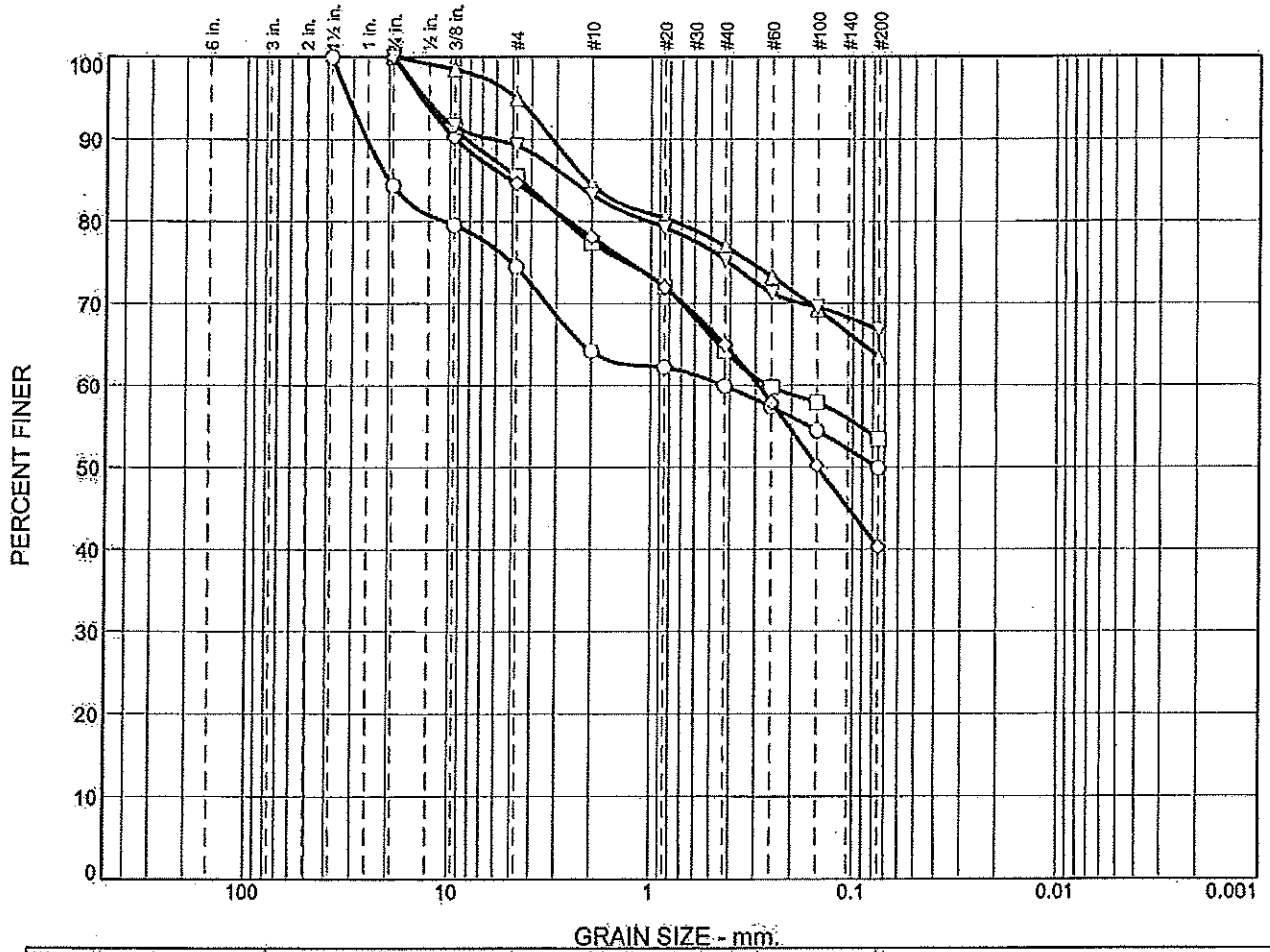

	% Cobbles	% Gravel		% Sand			% Fines
		Coarse	Fine	Coarse	Medium	Fine	
○	0.0	15.6	9.9	10.3	4.2	10.1	49.9
□	0.0	0.0	14.5	8.1	13.2	10.8	53.4
Δ	0.0	0.0	5.0	10.5	7.5	13.5	63.5
◇	0.0	0.0	15.4	6.5	13.1	24.7	40.3
▽	0.0	0.0	10.7	6.0	7.9	8.6	66.8

SOIL DATA					
SYMBOL	SOURCE	SAMPLE NO.	DEPTH (ft.)	Material Description	USCS
○	TP-1	S-1	1	Fine to coarse Gravel, and Silt, some f-c Sand. (MC=20.7%)	Fill
□	TP-1	S-2	3	Clayey Silt, some f-c Sand, little fine Gravel. (MC=18.6%)	ML
Δ	TP-3	S-1	3	Clayey Silt, some f-c Sand, trace fine Gravel. (MC=21.4%)	ML
◇	TP-3	S-2	5	Fine to coarse Sand, and Silt, little fine Gravel. (MC=14.1%)	SM
▽	TP-6	S-1	1.5	Clayey Silt, some f-c Sand, little fine Gravel. (MC=21.0%)	ML

Melick-Tully & Associates, P.C.

South Bound Brook, NJ

Client: CRH Realty VIII, LLC

Project: Proposed New Medical Office Building, Newburg, NY

Project No.: 9157-001

Plate SA

Gradation Curve(s)

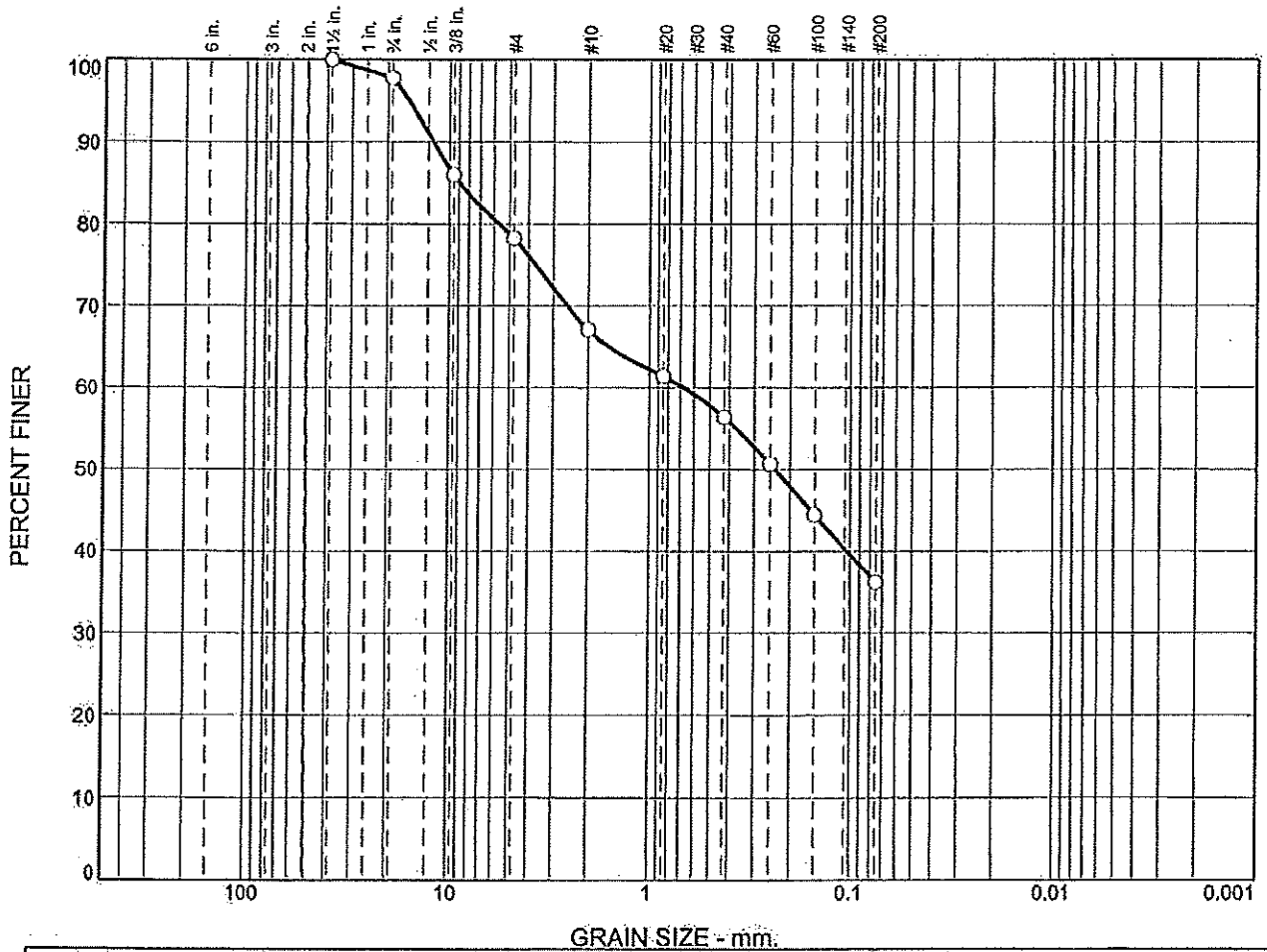

	% Cobbles	% Gravel		% Sand			% Fines
		Coarse	Fine	Coarse	Medium	Fine	
Q	0.0	2.2	19.5	11.2	10.7	20.2	36.2

SOIL DATA					
SYMBOL	SOURCE	SAMPLE NO.	DEPTH (ft.)	Material Description	USCS
Q	TP-6	S-2	4	Fine to coarse Sand, and Silt, some f-c Gravel. (MC=12.8%)	SM

Melick-Tully & Associates, P.C.

South Bound Brook, NJ

Client: CRH Realty VIII, LLC

Project: Proposed New Medical Office Building, Newburg, NY

Project No.: 9157-001

Plate 5B

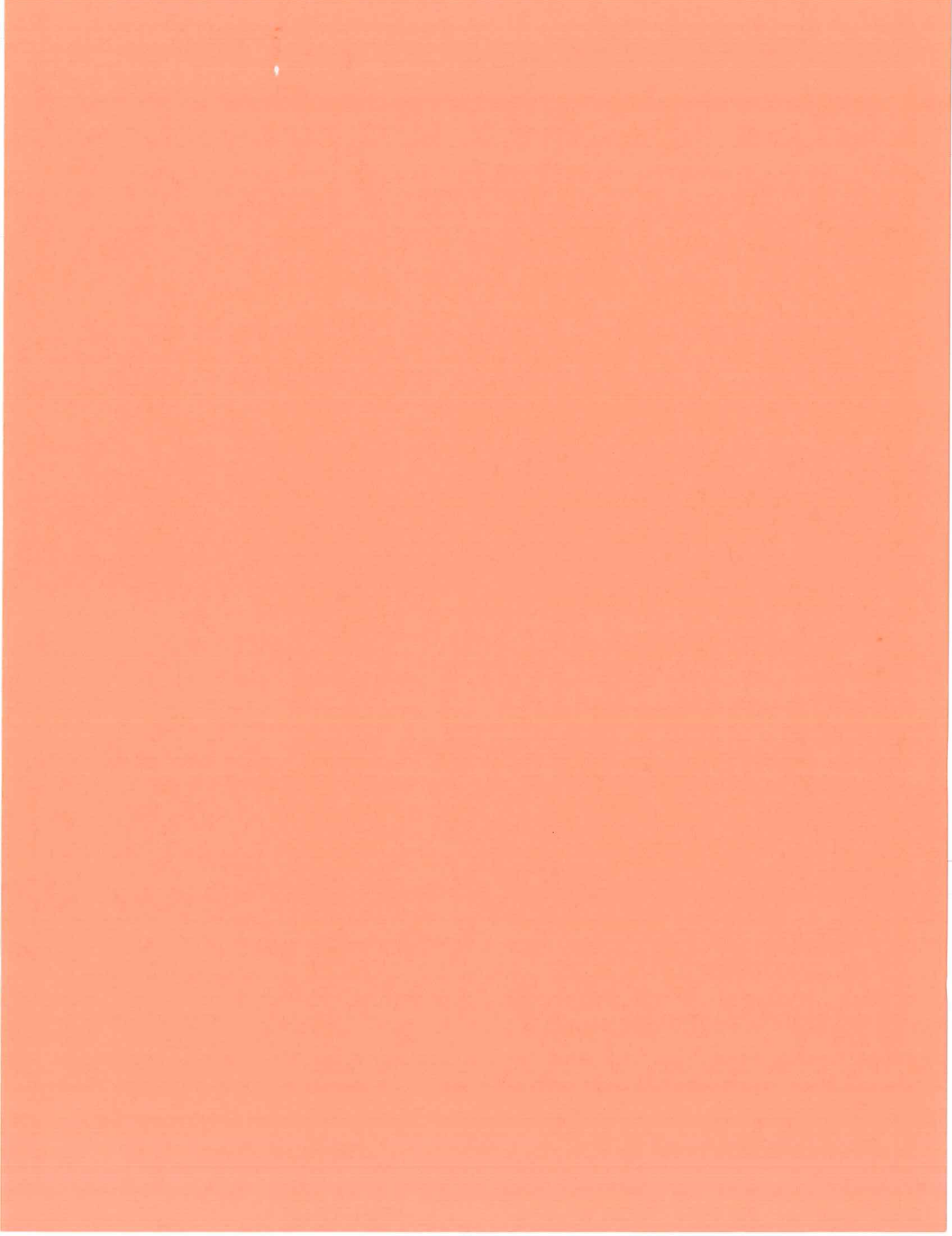

APPENDIX K

SITE PLANS
(ATTACHED)