

Andrew J. Zarutskie
Town Clerk
Town of Newburgh
1496 Route 300
Newburgh NY 12550, Tel.(845) 564-4554

AGENDA

AUDIT/WORKSHOP TOWN COUNCIL MEETING

Wednesday, August 21, 2013

7:00 p.m.

1. ROLL CALL
2. PLEDGE OF ALLEGIANCE TO THE FLAG
3. MOMENT OF SILENCE
4. CHANGES TO AGENDA
5. APPROVAL OF AUDIT
- 5A. PRESENTATION: Peace Bell Foundation
6. WATER SUPPLY: Presentation by SABO
7. UNSAFE BUILDINGS UPDATE:
 - A. 408 Carter Avenue
 - B. 37 Taft Avenue
8. FLEET MAINTENANCE:
 - A. Class 8 Truck Purchase
 - B. Shelter Building
 - C. Manheim Purchase Proposal
9. ANIMAL CONTROL:
 - A. Painting of Kennel Floors T-94
 - B. Outside Kennel Pavillion -- discussion
 - C. Replacement Vehicle
 - D. T-94 Withdrawal
10. RECREATION:
 - A. Trolley Request
 - B. Hiring of Part Time Chauffer
11. POLICE: Purchase of Equipment
12. ASSESSOR: Hiring of Auditor
13. PUBLIC ENTERTAINMENT PERMIT APPLICATION
14. STORAGE CONTAINER LOCAL LAW: Review
15. RESOLUTION to Schedule Public Hearing for Tax Levy Cap Local Law
16. ENGINEERING:
 - A. Water Treatment Chemical Bid
 - B. Stewart Water Storage Tank
17. ACCOUNTING: Software Upgrade Purchase (Computer Reserve)
18. PLANNING BOARD: Landscape Bond Estimate
19. DATA PROCESSING
20. POSSIBILITY OF EXECUTIVE SESSION: Litigation (Melon Trucking)
21. ADJOURNMENT

5. APPROVAL OF AUDIT

AUG 21 2013

AUDIT # 15
8/21/2013
VOUCHERS: 133185 to 133472

6

Audit Date: August 21, 2013

To the Supervisor:

I certify that the vouchers listed above were audited by the Town Board on the above date and allowed in the amounts shown. You are hereby authorized and directed to pay each of the claimants the amount opposite his name.

I acknowledge the following vouchers are in violation of New York State's General Municipal Law section 103 (Competitive Bidding Laws) and approve payment thereof.

<u>Voucher</u>	<u>Vendor Name</u>	<u>Amount</u>
133218	Newburgh winwater	480.00
133219	Newburgh winwater	129.75
133220	Newburgh winwater	2,356.08
133221	Newburgh winwater	2,534.85
133222	Newburgh winwater	237.00
133242	Val u office	1,059.28
133293	Alamo group	20,599.90
133296	Camo pollution	3,525.00
133323	NY Communication	3,725.00
133366	Newburgh winwater	235.66
133367	NY Communication	9,034.00
133368	NY Communication	247.00
133374	Schmidts wholesale	818.33
133375	Schmidts wholesale	465.00
133422	Newburgh winwater	42.78
133423	NY Communication	112.56
133437	Val u office	546.26
133461	Tilcon corp	4,409.88
133462	Tilcon corp	5,560.21
133463	Tilcon corp	287.24
133464	Tilcon corp	433.74
133465	Tilcon corp	2,028.65

Dated: _____

Andrew J. Zarutskie, Town Clerk

Town Board:

Exceptions:

AUDIT # 15

August 21, 2013

VOUCHERS: 133185 to 133472

FUND	REGULAR	PREPAID
GENERAL	\$ 478,285.88	\$ 245,803.94
TRUST & AGENCY	12,734.65	864.83
STREET LIGHTING	-	15,566.76
HIGHWAY	354,039.20	63,342.62
WATER	204,447.20	26,186.48
SEWER	11,556.59	6,433.78
WATER CAPITAL	257,726.22	-
SEWER CAPITAL	2,000.00	-
HIGHWAY CAPITAL	-	-
GENERAL CAPITAL	6,552.00	-
SPECIAL DISTRICT	-	-
TOTAL	\$ 1,327,341.74	\$ 358,198.41
GRAND TOTAL	<u>\$ 1,685,540.15</u>	

5A.PRESENTATION: Peace Bell Foundation

Ja

Councilman Piaquadio

From: DOUGMARBEL@aol.com
Sent: Friday, August 16, 2013 1:43 PM
To: councilmanpiaquadio@hvc.rr.com
Subject: Re: On the Town Meeting Schedule?

ok thanks for the update...

Blessings Of Peace, Love, Service, Joy, Fun & Awe!

Doug Martin Sturomski

**Become an Example and Inspiration to all
Ringing true in truth
Resonating with love and
Fine Tuning within and without
The subtle textures of Peace!**

**Imagine peace, Think peace,
Act peace, Spread peace, Live peace
Be that Light in darkness!**



In a message dated 8/16/2013 10:11:22 A.M. Eastern Daylight Time, councilmanpiaquadio@hvc.rr.com writes:

Doug
The Supervisor will place you on the agenda for Wednesday August 21st 7:00 PM
at 1496 Route 300 Newburgh
Please limit the presentation to 10 to 15 minutes
Thank you
Gil

6. WATER SUPPLY: Presentation by SABO



Edward A. Diana
County Executive

AUG 21 2013

DEPARTMENT OF HEALTH

Eli N. Avila, MD, JD, MPH, FCLM
Commissioner of Health
124 Main Street
Goshen, New York 10924-2199

Environmental Health

(845) 291-2331
Fax: (845) 291-4078

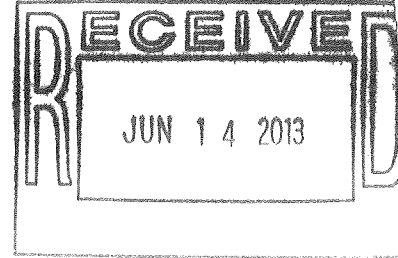

June 10, 2013

Salvador Boutureira
SABO Industrial Corp.
2 Little Britain Rd.
Newburgh, NY 12550

RE: Newburgh Cons.
ID #3503578
Chemical Pilot Study

Dear Mr. Boutureira:

We are in receipt of your letter dated May 23, 2013 regarding the proposal to use a new chemical for water treatment at the Chadwick Lake facility. Prior to conducting the pilot study, please provide our office with the following additional information:

- Is this chemical intended to replace the existing coagulant? Or is it to be used in addition to the water treatment already being utilized?
- If replacement is intended, how close is this chemical to its replacement?

If you have additional questions or comments please feel free to contact the undersigned directly at 845-291-2473 or via email at sgagnon@orangecountygov.com.

Best regards,

Steven Gagnon, P.E.
Sr. Public Health Engineer

Cc: Supervisor & Town Board
John Egitto, CAMO, ORC
Jeff Guido, CAMO, ORC
J. Osborne, P.E., Town Engineer
file

7. UNSAFE BUILDINGS UPDATE:
 - i. 408 Carter Avenue
 - ii. 37 Taft Avenue

No Information Available at This Time

8. FLEET MAINTENANCE:

- i. Class 8 Truck Purchase**
- ii. Shelter Building**
- iii. Manheim Purchase Proposal**

AUG 21 2013

B abc

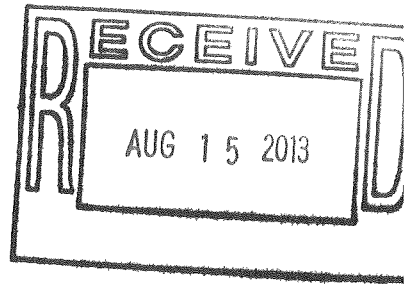

**TOWN OF NEWBURGH
FLEET MAINTENANCE
88 GARDNERTOWN ROAD
NEWBURGH, NY 12550
(845) 561-2288 Fax# (845) 561-3975**

TO: Wayne Booth, Supervisor

FROM: James LaColla, Head Mechanic-Fleet Maintenance

A handwritten signature in black ink, appearing to be "J. LaColla", enclosed in a circular scribble.

DATE: August 15, 2013

RE: August 21st Audit Meeting

cc: Andrew Zarutski, Town Clerk

I would like the following items to be placed on the August 21st Audit meeting agenda:

- A.*
- B.* Shelter (Fleet Maintenance Bldg)
- C.* Manheim Proposal

Highway Dept. Truck Purchase

Thank You

9. ANIMAL CONTROL:

- A. Painting of Kennel Floors T-94**
- B. Outside Kennel Pavilion -- discussion**
- C. Replacement Vehicle**
- D. T-94 Withdrawal**

3

TOWN OF NEWBURGH
SUMMARY OF QUOTATION FORM

REQUESTED BY: Charnel Wright

DATE PREPARED: 8.7.13

ITEM/SERVICE PURCHASED Paint Kennel Area

VENDOR NAME Infinite Construction

Epoxi Professionals

Rays General Contract

ADDRESS

11 Stony Hill Rd

179 Meadowcroft Rd

CITY/STATE/ZIP

Newburgh NY

Danbury, CT 06811

Naugatuck, CT 067-

PHONE #

845-489-5359

888-775-0005

203 841 7018

CONTACT PERSON

Chad Kip

Goec / Daniel /
Based upon 1200SF

Ray Gardner

PRICE QUOTED

\$9,400

5,300

8,400

EXPIRATION DATE

Sept 30, 2013

VENDOR CHOSEN

Epoxi Professionals

*NOTE: If the vendor you wish to purchase from did not give the lowest quote, state reason why you did not purchase from the lowest cost vendor.

DEPARTMENT HEAD SIGNATURE

[Signature]

DATE:

(ATTACH ANY WRITTEN QUOTES, IF REQUIRED)

AUG 21 2013

EPOXI PROFESSIONALS

(Detroit) 50495 Heatherwood Ln Shelby Twp, MI.

(Chicago) 1000 West Devon Ave. Elk Grove Village

(Connecticut) 11 Stony Hill Road, Danbury

Office(800) 775-0005

Fax: (586) 323-8966

*↑
wrong #???*

8/9/2013

Customer:

Shantel

(845) 561-3344

New Berg Town of Animal Control

Job Location: 645 Gidney Ave. NewBerg, NY 11550

SCOPE OF WORK

1. Grind the surface to allow the epoxy to soak into concrete
2. Fill the crack's and holes in areas needed
3. Vacuum and blow the floor (dust-free)
4. Apply two coats of 100% epoxy (30mils thick)
5. Apply colored paint flakes on top of epoxy color of flakes to be of customer's choice
6. One coat Clerical Poly Urethane top coat (3mils thick)
7. Urethane is 100% urine free
8. 2 years warranty labor and material
9. The manufacturer of Epoxy that we install is owned by Duraflex

Material, Labor and equipment included

Total Sq. Footage 933

Payment Terms: \$5,300 due when floor is finished. Please mail check to Michigan office: 50495 Heatherwood Ln Shelby Twp, MI.

Total Charge = \$5,300

****Total payment is due and required at the time of job completion****

Customer Sign

X _____

JOB INVOICE

Corporate Construction
 Chad C. Kip
 845-489-5359

TO Newburgh Naval Shelter
 ADDRESS _____
 ATTENTION NO Antenna Mast

DATE ORDERED _____ ORDER TAKEN BY _____
 PHONE NO. _____ CUSTOMER ORDER # _____
 JOB LOCATION _____
 JOB PHONE _____ STARTING DATE _____
 TERMS _____

CITY	MATERIAL	UNIT	AMOUNT
	inside and outside of the rear dog kennel area, consisting of any epoxy black or concrete in that perimeter will be stripped of existing finish down to bare cement surface. Area will be then pressure washed to remove loose dirt particles. Armor Poly primer/adhesion promoter will then be applied followed by our base color Armor Poly epoxy (color of choice) and cost will be a Armor Poly clear coat finish followed by a wear resistant Armor Poly top coat. A traction non-skid additive will be applied on floors only.		
	- 4 PART SYSTEM -		

DESCRIPTION OF WORK			
Armor Poly offers a 5 year warranty. Note: With this application it will not be required to remove this product to apply a new finish. Simply re apply the wear resistant topcoat when heavy wear should occur.			
MISCELLANEOUS CHARGES			
Should any additional work that is requested prior about a contract will have to be made before starting date of that particular job.			
LABOR	HRS.	RATE	AMOUNT
Deposit			\$4700
Balance			\$4700
			\$9400

WORK ORDERED BY _____
 DATE ORDERED _____
 DATE COMPLETED _____

CUSTOMER APPROVAL SIGNATURE _____
 AUTHORIZED SIGNATURE _____

TOTAL LABOR	
TOTAL MATERIALS	
TOTAL MISCELLANEOUS	
SUBTOTAL	\$9,400
TAX	
GRAND TOTAL	\$9,400

RAY'S GENERAL CONTRACTING
Certified Armor Poxy Installer
179 Meadow Lark Road
Naugatuck, CT 06770
(203) 841-7048

Proposal

Date	Proposal #
7/18/2013	7182

ADDRESS

Town of Newburgh
Animal Control Dept7 Animal Shelter
Contact Person Chantel Haight
645 Gidney Avenue Newburgh N.Y. 12550
Phone: 845-561-3344
Email: newburghaco@aol.com

DESCRIPTION

AMOUNT

We recommend the following; Start with a surface grind inside and out to remove all existing coatings, a hand grinder will be used to grind all around the edges and near the walls. The next step will be to clean the entire surface with T.S.P. and power wash it, once this surface is dry we will apply a two part epoxy primmer, this will take approx. 3 hrs. to dry, then we will be able to apply the next coat of epoxy {Armor Ultra} with a three color flake pattern. The following day we can apply the top coat 322 military grade. The cost will be \$ 7.00 per Sq./Ft @ 1200 Sq./Ft = \$ 8,400

We can add an additional top coat for longer durability for an additional \$ 1,200

The warranty for this product is one year on labor and material, if any problem with the product or installation it will be corrected with no charge to the customer.

If interested call or email anytime. Any questions let me know.

Thank you

Ray Cordova
Rays General Contracting

MUNICIPAL SHELTER INSPECTION REPORT - DL-90

Rating: **Satisfactory365**

Purpose: **Inspection**

DATE/TOA: **3/26/13 11:30 am**

NEWBURGH TOWN DOG SHELTER
645 GIDNEY AVE
NEWBURGH NY 12550

Inspector: **Eloise Herrman**

Inspector #: **18**

Inspector: **Kim Volpe**

Inspector #: **61**

These are the findings of an inspection of your facility on the date(s) indicated above:

- | | |
|--|----------------|
| 1. Shelter is structurally sound | Yes |
| 2. Housing area and equipment is sanitized regularly
<i>Bleach and Quat 32</i> | Yes |
| 3. Repairs are done when necessary
<i>The runs need to be resealed/painted to properly provide an impervious surface for disinfecting as soon as possible.</i> | No |
| 4. Dogs are handled safely | Yes |
| 5. Adequate space is available for all dogs | Yes |
| 6. Light is sufficient for observation | Yes |
| 7. Ventilation is adequate | Yes |
| 8. Drainage is adequate | Yes |
| 9. Temperature extremes are avoided | Yes |
| 10. Clean food and water is available and in ample amount | Yes |
| 11. Veterinary care is provided when necessary
<i>Newburgh Veterinary Hospital and Flannery Animal Hospital</i> | Yes |
| 12. Dogs are euthanized humanely, by authorized personnel
<i>Newburgh Veterinary Hospital and Flannery Animal Hospital</i> | Yes |
| 13. Complete intake and disposition records are maintained for all seized dogs
<i>Paperwork is well maintained!</i> | Yes |
| 14. Dogs transferred for purposes of adoption in compliance with Article 7 | Yes |
| 15. Redemption period is observed before adoption, euthanasia or transfer | Yes |
| 16. Owners of identified dogs are properly notified | Yes |
| 17. Redeemed dogs are licensed before release | Yes |
| 18. Proper impoundment fees paid before dogs are released | Yes |
| 19. Written contract or lease with municipality | Not Applicable |

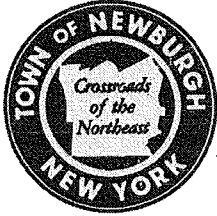

TOWN OF NEWBURGH ANIMAL CONTROL &
SHELTER

645 GIDNEY AVE. NEWBURGH, NY 12550

(845)561-3344

FAX: (845)561-2220

animalcontrol@hvc.rr.com

To: Wayne Booth, Supervisor, Town Board, Les Cornell, Building and Grounds
From: Chantel Haight, Animal Control Supervisor
Date: July 31, 2013
Re: Painting of Kennel Floors

The floors in the kennel area are in deplorable condition and need resealing or repainting. There is little remaining paint, leaving a porous surface. At the time of our last State inspection, we were advised to reseal as soon as possible.

Attached please find the state inspection with the pertinent section highlighted.

Please also find several estimates for resealing with an epoxy type product.

Be advised that this work needs to be done in warm weather, due to the curing process.

I am requesting that this project be given priority, so we can remain in compliance with state requirements.

Thank you for your consideration of this matter.

AUG 21 2013

90



C-100

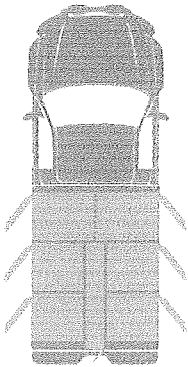

We've made it easier than ever to get moving with one of the most popular configurations in the industry. With a one-piece molded fiberglass shell and sealed steel frame, we've packaged the options you want at an unbeatable price!

- 6 animal compartments with rear storage compartment*
- Fresh air ventilation system vented to each compartment*
- Pass-through swing door in front compartment*
- LED compartment lighting*
- Back-up alarm and four-way flashers*

www.customfiberglasscoaches.com

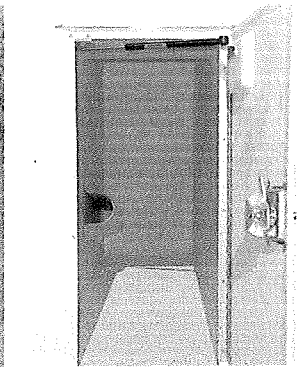

C-100 SPECIFICATIONS

FOR COMPLETE SPECS & PRICING, CALL 800.831.0960 NOW

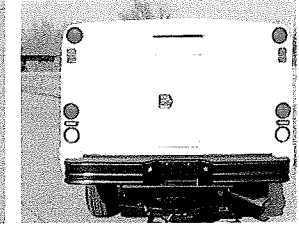
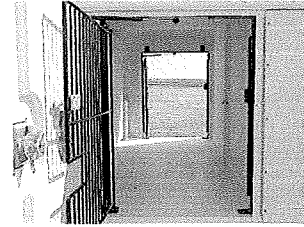

Standard Equipment

Construction & Finish

- Reinforced One-Piece Molded Fiberglass Construction
- Gel-coated fiberglass doors
- Bright white gelcoat high gloss exterior finish
- Molded fiberglass ground effects
- Step bumper with tread plate top
- Stainless steel hardware throughout

Interior Features

- 6 animal compartments
- Sloped floor drainage system
- Pass-through swing door in the front compartment
- Storage compartment with rear access and catch pole holder
- Stainless steel tube roof rack
- User friendly and easy to clean

Climate Control

- Fresh air ventilation system vented to each compartment
- Five molded louver vents in exterior door panels with airflow control vents

Efficient Illumination

- Bright white L.E.D. lighting in compartments
- L.E.D. brake, running and reverse lights
- All wiring color-coded & in conduit to protect from animals
- Easily-accessible junction boxes for future options, etc.

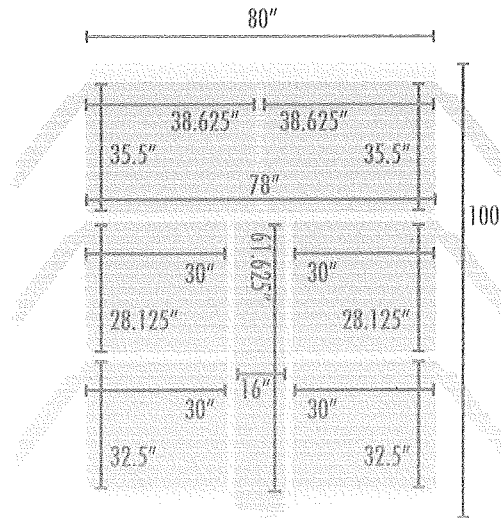

Exterior Height: 45"

Interior Height: 36"

Weight: Approximately 800 lbs.

Truck Chassis Requirements:
Must be a standard long bed truck chassis with a 56" cab-to-axle (CA) measurement. And it must have single rear wheels.

Optional Equipment

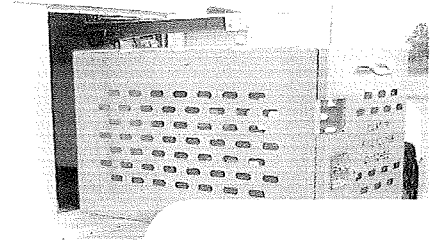
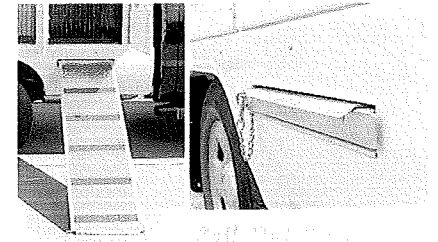

- Air Conditioning and Heating w/ Digital temperature monitoring
- Heavy duty interior safety doors
- Additional catch pole holder
- Additional work & safety lights
- Rear blind spot mirror
- PetStep folding ramp
- Shelving
- Rear vision camera system

More options available. Call for details!

www.customfiberglasscoaches.com

Wayne Booth

Custom Fiberglass COACHES

QUOTATION

Bowie International, LLC
313 South Hancock
Lake City, IA 51449
P: 800-831-0960 F: 712-464-8601

QUOTATION NO. 062613-2
DATE August 7, 2013
CUSTOMER ID Town of Newburgh, NY

TO Chantel Haight
Town of Newburgh Animal Control
645 Gidney Avenue
Newburgh, NY 12550
845-561-3344



SALESPERSON	JOB	PAYMENT TERMS	DUE DATE
Steve Sinnard		Net 30	

QUANTITY	DESCRIPTION	UNIT PRICE	LINE TOTAL
1.00	Model C-100 Animal Transport Unit w/ rear storage	\$ 10,795.00	10,795.00
	Includes: Roof rack, all L.E.D. Lighted compartments, forced air ventilation system, back-up alarm, Hi-Lo brake lights, bumper extensions, Fiberglass doors with molded louvers, stainless steel T- Lock Handles, keyed alike locks, ground effects, solid partitions gel coat sealed and webbed interior, clearance lights, pass through swing door in front compartment; floor drainage trough, catch pole holder in storage, step bumper with tread plate top		
3.00	Heavy Duty Interior Safety Door - powdercoated black (only 3)	145.00	435.00
1.00	Delete Roof Rack	(100.00)	(100.00)
1.00	Air Conditioning & Heating System w/ temperature monitoring	2,050.00	2,050.00
	Drop ship new truck to our location		
1.00	Free installation of body at our facility in Lake City, IA	-	-
1.00	Delivery of completed truck via transport to Newburgh, NY	-	-

SUBTOTAL	\$ 13,180.00
SALES TAX	
TOTAL	\$ 13,180.00

Custom Fiberglass Coaches is a subsidiary of Bowie International, LLC

Make all purchase orders and checks to Bowie International, LLC
www.customfiberglasscoaches.com email: ask@customfiberglasscoaches.com

90

AUG 21 2013



TOWN OF NEWBURGH ANIMAL CONTROL & SHELTER

645 Gidney Ave. Newburgh, NY 12550

December 10, 2012

To: Town Board

Subject: Authorization to Pay Veterinarian Services Utilizing T-93 Account

I am requesting authorization to use the T-94 account to pay for veterinarian services from Newburgh Veterinary Hospital for July and for your authorization for payment of this voucher in the total amount of ~~\$1211.12.~~

Sincerely,

Chantel Haight
Animal Control Supervisor

CH
8967
1360.19 *\$1300.19*

Cc: Accounting

TOWN OF NEWBURGH

1496 Route 300
Newburgh, New York 12550
(845) 564-4552

DO NOT WRITE IN THIS BOX

Date Voucher Received		VOUCHER NO.
FUND - APPROPRIATION	AMOUNT	
Total		
Abstract #		

DEPARTMENT _____

CLAIMANT'S
NAME
AND
ADDRESS

NEWBURGH VETERINARY HOSPITAL
1716 Route 300
Newburgh, NY 12550
Tel: (845) 564-2660
www.newburghvet.com

TERMS Net 30 Days

Invoice # _____

Feline

Dates	Quantity	Description of Materials or Services	Unit Price	Amount
7/5/13	551942			303.65
7/6/13	552070			86.98
7/6/13	552373			401.00
7/18/13	553008			419.49
			TOTAL	1211.12

CLAIMANT'S CERTIFICATION

I, Dora M Cast certify that the above account in the amount of \$ 1211.12 is true and correct; that the items, services and disbursements charged were rendered to or for the municipality on the dates stated; that no part has been paid or satisfied; that taxes, from which the municipality is exempt, are not included; and that the amount claimed is actually due.

8/5/13
DATE

Dora M Cast
SIGNATURE

Bookkeeper
TITLE

(Space below for municipal use)

DEPARTMENT APPROVAL

The above services or materials were rendered or furnished to the municipality on the dates stated and the charges are correct.

Date

Authorized Official

APPROVAL FOR PAYMENT

This claim is approved and ordered for paid from the appropriations indicated above

Date

Auditing Board

INVOICE

Newburgh Veterinary Hospital

1716 Route 300
Newburgh, NY 12550
845 564-2660

"Your pet is part of our family too." Visit us at www.newburghvet.com

FOR: Town of Newburgh - Feline
645 Gidney Ave.
Newburgh, NY 12550
(845) 561-3344

Printed: 08-05-13 at 12:18p
Date: 07-05-13
Account: 4417
Invoice: 551942

Date	For	Qty	Description	Price	Discount	Net Price	
06-19-13	Sweet Tea	1	CONSULT / EXAM - Annual Welln	46.50	23.25	23.25	**
06-19-13		1	Revolution Cat 5.1-15lb single	18.50	9.25	9.25	**
06-19-13		1	FeLV/FIV Elisa-SA260	67.50	33.75	33.75	**
06-21-13		1	FIV Elisa Negative			0.00	
06-21-13		1	Feline Leukemia Elisa Negative			0.00	
06-21-13		1	OHE FELINE	129.50	64.75	64.75	**
<p>Your pet has been spayed. This eliminates the risk of uterine infection and lowers the risk of breast tumors when she gets older. Expect her to be quiet and not as active for a couple of days. Restrict exercise for the next two weeks. This receipt certifies that your pet has been spayed. Please keep this with your pet's health records.</p>							
06-21-13		1	-Isoflurane Gas Anesthesia			0.00	
06-21-13		1	Feline Rhino/Panleuk/Calici #1	25.00	12.50	12.50	**
<p>Your cat has received the first in a series of immunizations to protect him/her against feline distemper, rhinotracheitis, and calicivirus. It is important to return for a followup booster in 3-4 weeks. Occasionally listlessness, lethargy, or localized discomfort may occur. If there is severe listlessness or facial swelling, please call us for advice.</p>							
06-21-13		1	RecommendFecal (please dropoff			0.00	
<p>Annual fecal microscopic exams are very important for the health of your pet and, since some worms are transmissible to humans, for the health of your family. Please bring us your pet's fecal sample at your earliest convenience</p>							
06-21-13		1	Zoonoses			0.00	
<p>Discussed Zoonotic potential of intestinal parasites- in particular roundworms.</p>							
06-21-13		0.03	Morphine Inject / ml			0.00	
06-21-13		0.01	Telazol Injectable / 1 ml			0.00	
06-25-13	Rosie	0.04	Morphine Inject / ml			0.00	
06-25-13		0.04	Telazol Injectable / 1 ml			0.00	
06-25-13		1	OHE FELINE	129.50	64.75	64.75	**
<p>Your pet has been spayed. This eliminates the risk of uterine infection and lowers the risk of breast tumors when she gets older. Expect her to be quiet and not as active for a couple of days. Restrict exercise for the next two weeks. This receipt</p>							

certifies that your pet has been spayed. Please keep this with your pet's health records.

06-25-13		1 -Isoflurane Gas Anesthesia			0.00
06-25-13		1 FELINE RHINO/PANLEUK/CALICI	25.00	12.50	12.50 **
Your pet has been immunized against feline distemper, rhinotracheitis, and calicivirus. Occasionally listlessness, lethargy, or lack of appetite may occur. If severe listlessness or facial swelling occurs, please call us for advice.					
06-25-13		1 Feline rabies/Purevax 1yr	29.00	14.50	14.50 ** 12.50
Today, your cat received the most advanced rabies protection available. PUREVAX Rabies vaccine gives your cat protection that is pure, safe and effective without the use of potentially harmful adjuvants.					
06-25-13		1 Amoxicillin Drops 15ml (50mg/ml)	18.60	9.30	9.30 ** ?
06-25-13	Sweet Tea	1 Feline Leukemia Elisa Negative			0.00
06-25-13		1 FIV Elisa Negative			0.00
06-26-13	3orange/1black	1 CONSULT / EXAM - Sick	59.00	29.50	29.50 **
06-26-13		1 Pet Insurance Review			0.00
Please visit www.petinsurancereview.com and dogtime.com for an independent review of all national pet health insurance plans					
06-26-13	Rosie	1 Clavamox Drops #169319	35.00	17.50	17.50 **
06-27-13	3orange/1black	1 Albon Suspension (50mg/ml) 1 oz :	24.19	12.09	12.10 **
Total charges, this invoice...					303.65
**Total discount included: 303.64					

Your invoice total reflects our **13Stray Cat Accounts** discount.

LIKE US ON FACEBOOK.COM!

GOING AWAY?...BOOK YOUR PETS BOARDING RESERVATION TODAY!

In compliance with New York State law, all medications are non-refundable. We regret any inconveniences.

INVOICE

Newburgh Veterinary Hospital

1716 Route 300
Newburgh, NY 12550
845 564-2660

"Your pet is part of our family too." Visit us at www.newburghvet.com

FOR: Town of Newburgh - Feline
645 Gidney Ave.
Newburgh, NY 12550
(845) 561-3344

Printed: 08-05-13 at 12:18p
Date: 07-06-13
Account: 4417
Invoice: 552070

Date	For	Qty	Description	Price	Discount	Net Price
07-05-13	Rosie	1	CONSULT / EXAM - Followup	39.75	19.87	19.88 **
07-05-13		1	Pet Insurance Review			0.00
Please visit www.petinsurancereview.com and dogtime.com for an independent review of all national pet health insurance plans						
07-05-13		1	SUBCUTANEOUS FLUIDSx_____	36.50	18.25	18.25 **
07-05-13		1	-MULTIPLE INJECTIONS	68.50	34.25	34.25 **
07-05-13		1	Albon Suspension (50mg/ml) 1 oz :	24.19	12.09	12.10 **
07-05-13		1	Capstar administration	5.00	2.50	2.50 **
Total charges, this invoice...						86.98
**Total discount included: 86.96						

Your invoice total reflects our **13Stray Cat Accounts** discount.

LIKE US ON FACEBOOK.COM!

GOING AWAY?....BOOK YOUR PETS BOARDING RESERVATION TODAY!

In compliance with New York State law, all medications are non-refundable. We regret any inconveniences.

INVOICE

Newburgh Veterinary Hospital

1716 Route 300
 Newburgh, NY 12550
 845 564-2660

"Your pet is part of our family too." Visit us at www.newburghvet.com

FOR: Town of Newburgh - Feline
 645 Gidney Ave.
 Newburgh, NY 12550
 (845) 561-3344

Printed: 08-05-13 at 12:17p
Date: 07-10-13
Account: 4417
Invoice: 552373

Date	For	Qty	Description	Price	Discount	Net Price
07-09-13	Kittens 7/9/13	1	OHE FELINE Your pet has been spayed. This eliminates the risk of uterine infection and lowers the risk of breast tumors when she gets older. Expect her to be quiet and not as active for a couple of days. Restrict exercise for the next two weeks. This receipt certifies that your pet has been spayed. Please keep this with your pet's health records.	129.50	64.75	64.75 **
07-09-13		1	-Isoflurane Gas Anesthesia			0.00
07-09-13		4	NEUTER/FELINE	200.00	100.00	100.00 **
07-09-13		5	Frontline Plus Cat Single	92.50	46.25	46.25 **
07-09-13		5	Feline Rhino/Panleuk/Calici #2 Your cat has received the second in a series of immunizations to protect her/him against Feline Distemper, Rhinotracheitis, and Calicivirus. It is important to return for a final booster in 3-4 weeks. Occasionally listlessness or localized discomfort might occur for the next few days. If you notice excessive listlessness or facial swelling, please call us for advice.	125.00	62.50	62.50 **
07-09-13		5	Recommend Fecal (please dropoff) Annual fecal microscopic exams are very important for the health of your pet and, since some worms are transmissible to humans, for the health of your family. Please bring us your pet's fecal sample at your earliest convenience			0.00
07-09-13		5	Zoonoses Discussed Zoonotic potential of intestinal parasites- in particular roundworms.			0.00
07-09-13		1	Consult exam litter (3 or more)	125.00	62.50	62.50 **
07-09-13	Orange Euthanas	1	Shelter euthanasia and body care f			65.00
Total charges, this invoice...						401.00
**Total discount included: 336.00						

Your invoice total reflects our **13 Stray Cat Accounts** discount.

INVOICE

Newburgh Veterinary Hospital

1716 Route 300
Newburgh, NY 12550
845 564-2660

"Your pet is part of our family too." Visit us at www.newburghvet.com

FOR: Town of Newburgh - Feline
645 Gidney Ave.
Newburgh, NY 12550
(845) 561-3344

Printed: 08-05-13 at 12:17p
Date: 07-18-13
Account: 4417
Invoice: 553008

Date	For	Qty	Description	Price	Discount	Net Price
07-11-13	Stray 7/11/13a	1	NEUTER/FELINE	50.00	25.00	25.00 **
07-11-13		1	Feline rabies/Purevax 1yr	29.00	14.50	14.50 ** <i>nanst</i>
Today, your cat received the most advanced rabies protection available. PUREVAX Rabies vaccine gives your cat protection that is pure, safe and effective without the use of potentially harmful adjuvants.						
07-11-13		1	FelLV/FIV ELISA in hosp	73.00	36.50	36.50 **
07-11-13		1	FELINE RHINO/PANLEUK/CALICI	25.00	12.50	12.50 **
Your pet has been immunized against feline distemper, rhinotracheitis, and calicivirus. Occasionally listlessness, lethargy, or lack of appetite may occur. If severe listlessness or facial swelling occurs, please call us for advice.						
07-11-13		1	Revolution Pup/Kitten 1-5lb single	14.50	7.25	7.25 **
07-11-13	Stray 7/11/13b	1	FelLV/FIV ELISA in hosp	73.00	36.50	36.50 **
07-11-13		1	FELINE RHINO/PANLEUK/CALICI	25.00	12.50	12.50 **
Your pet has been immunized against feline distemper, rhinotracheitis, and calicivirus. Occasionally listlessness, lethargy, or lack of appetite may occur. If severe listlessness or facial swelling occurs, please call us for advice.						
07-11-13		1	Strongid deworming(roundworms, t	16.50	8.25	8.25 **
07-11-13		1	Zoonoses			0.00
Discussed Zoonotic potential of intestinal parasites- in particular roundworms.						
07-11-13		1	Revolution Pup/Kitten 1-5lb single	14.50	7.25	7.25 **
07-11-13	Stray 7/11/13c	1	FelLV/FIV ELISA in hosp	73.00	36.50	36.50 **
07-11-13		1	OHE FELINE	129.50	64.75	64.75 **
Your pet has been spayed. This eliminates the risk of uterine infection and lowers the risk of breast tumors when she gets older. Expect her to be quiet and not as active for a couple of days. Restrict exercise for the next two weeks. This receipt certifies that your pet has been spayed. Please keep this with your pet's health records.						
07-11-13		1	-Isoflurane Gas Anesthesia			0.00
07-11-13		1	Revolution Pup/Kitten 1-5lb single	14.50	7.25	7.25 **
07-11-13		1	Feline rabies/Purevax 1yr	29.00	14.50	14.50 **

Today, your cat received the most advanced rabies protection available. PUREVAX Rabies vaccine gives your cat protection that is pure, safe and effective without the use of potentially harmful adjuvants.

07-11-13		1 FELINE RHINO/PANLEUK/CALICI	25.00	12.50	12.50 **
	Your pet has been immunized against feline distemper, rhinotracheitis, and calicivirus. Occasionally listlessness, lethargy, or lack of appetite may occur. If severe listlessness or facial swelling occurs, please call us for advice.				
07-11-13		0.04 Telazol Injectable / 1 ml			0.00
07-11-13		0.04 Morphine Inject / ml			0.00
07-12-13	Stray 7/11/13a	1 Shelter board feline			12.50
07-12-13	Stray 7/11/13b	1 Shelter board feline			12.50
07-12-13	Stray 7/11/13c	1 Shelter board feline			12.50
07-13-13	Stray 7/11/13a	1 Revolution Cat 5.1-15lb (6 pack)	91.98	45.99	45.99 **
07-13-13		3 Capstar administration	15.00	7.50	7.50 **
07-18-13	Stray 7/11/13b	1 Erythromycin Ophthalmic Ointment	38.50	19.25	19.25 **
07-18-13		1 Lysine/Duralactin Dose Syringe #1	27.00	13.50	13.50 **
Total charges, this invoice...					419.49
**Total discount included: 381.99					

Your invoice total reflects our **13Stray Cat Accounts** discount.

LIKE US ON FACEBOOK.COM!

GOING AWAY?....BOOK YOUR PETS BOARDING RESERVATION TODAY!

In compliance with New York State law, all medications are non-refundable. We regret any inconveniences.

TOWN OF NEWBURGH

1496 Route 300
Newburgh, New York 12550
(845) 564-4552

original

DO NOT WRITE IN THIS BOX

Date Voucher Received		VOUCHER NO.
FUND - APPROPRIATION	AMOUNT	
Total		
Abstract #		

DEPARTMENT _____

CLAIMANT'S
NAME
AND
ADDRESS

NEWBURGH VETERINARY HOSPITAL
1716 Route 300
Newburgh, NY 12550
Tel: (845) 564-2660
www.newburghvet.com

TERMS Net 30 Days

Invoice # _____

Canine

Dates	Quantity	Description of Materials or Services	Unit Price	Amount
7/5/13	551961			54.50
7/6/13	552037			12.50
7/6/13	552071			29.50
7/12/13	552542			12.50
7/18/13	553005			184.57
			TOTAL	293.57

CLAIMANT'S CERTIFICATION

I, Doram Cast certify that the above account in the amount of \$ 293.57 is true and correct; that the items, services and disbursements charged were rendered to or for the municipality on the dates stated; that no part has been paid or satisfied; that taxes, from which the municipality is exempt, are not included; and that the amount claimed is actually due.

8/5/13
DATE

Doram Cast
SIGNATURE

Bookkeeper
TITLE

(Space below for municipal use)

DEPARTMENT APPROVAL

The above services or materials were rendered or furnished to the municipality on the dates stated and the charges are correct.

Date Authorized Official

APPROVAL FOR PAYMENT

This claim is approved and ordered for paid from the appropriations indicated above

Date Auditing Board

TOWN OF NEWBURGH

1496 Route 300
Newburgh, New York 12550
(845) 564-4552

DEPARTMENT _____

CLAIMANT'S
NAME
AND
ADDRESS

NEWBURGH VETERINARY HOSPITAL
1716 Route 300
Newburgh, NY 12550
Tel: (845) 564-2660
www.newburghvet.com

TERMS

Net 30 Days

Canine

DO NOT WRITE IN THIS BOX

Date Voucher Received		VOUCHER NO. _____
FUND - APPROPRIATION	AMOUNT	
	Total	
Abstract #		

Invoice # _____

Dates	Quantity	Description of Materials or Services	Unit Price	Amount
7/5/13	551961			54.50
7/6/13	552037			12.50
7/6/13	552071	(charge for Marie)		29.50
7/12/13	552542			12.50
7/18/13	553005			184.57
7/26/13	553803			<175.00>
8/7/13	554844	(credit for Marie)		<29.50>
TOTAL				

CLAIMANT'S CERTIFICATION

I, Dora M Cast certify that the above account in the amount of \$ 89.07 is true and correct; that the items, services and disbursements charged were rendered to or for the municipality on the dates stated; that no part has been paid or satisfied; that taxes, from which the municipality is exempt, are not included; and that the amount claimed is actually due.

8/9/13
DATE

Dora M Cast
SIGNATURE

Bookkeeper
TITLE

(Space below for municipal use)

DEPARTMENT APPROVAL

The above services or materials were rendered or furnished to the municipality on the dates stated and the charges are correct.

Date

Authorized Official

APPROVAL FOR PAYMENT

This claim is approved and ordered for paid from the appropriations indicated above

Date

Auditing Board

INVOICE

Newburgh Veterinary Hospital

1716 Route 300
Newburgh, NY 12550
845 564-2660

"Your pet is part of our family too." Visit us at www.newburghvet.com

FOR: Town of Newburgh - canine
645 Gidney Ave
Newburgh, NY 12550
(845) 561-3344

Printed: 08-05-13 at 12:02p
Date: 07-05-13
Account: 19984
Invoice: 551961

Date	For	Qty	Description	Price	Discount	Net Price
06-29-13	Canine	2	CANINE RABIES / 1YEAR	50.00	25.00	25.00 **
07-05-13	Heat Stroke 7/5	1	CONSULT / EXAM - Sick	59.50	30.00	29.50 **
07-05-13		1	Pet Insurance Review			0.00
Please visit www.petinsurancereview.com and dogtime.com for an independent review of all national pet health insurance plans						

Total charges, this invoice... 54.50

**Total discount included: 55.00

Your invoice total reflects our **13Stray Cat Accounts** discount.

LIKE US ON FACEBOOK.COM!

GOING AWAY?....BOOK YOUR PETS BOARDING RESERVATION TODAY!

In compliance with New York State law, all medications are non-refundable. We regret any inconveniences.

INVOICE

Newburgh Veterinary Hospital

1716 Route 300
Newburgh, NY 12550
845 564-2660

"Your pet is part of our family too." Visit us at www.newburghvet.com

FOR: Town of Newburgh - canine
645 Gidney Ave
Newburgh, NY 12550
(845) 561-3344

Printed: 08-05-13 at 12:02p
Date: 07-06-13
Account: 19984
Invoice: 552037

Date	For	Qty	Description	Price	Discount	Net Price
07-06-13	Sadie Taylor	1	CANINE RABIES / 1YEAR	25.00	12.50	12.50 ** 69-13
Total charges, this invoice...						12.50
**Total discount included: 12.50						

Your invoice total reflects our **13Stray Cat Accounts** discount.

LIKE US ON FACEBOOK.COM!

GOING AWAY?....BOOK YOUR PETS BOARDING RESERVATION TODAY!

In compliance with New York State law, all medications are non-refundable. We regret any inconveniences.

INVOICE

Newburgh Veterinary Hospital

1716 Route 300
Newburgh, NY 12550
845 564-2660

"Your pet is part of our family too." Visit us at www.newburghvet.com

FOR: Town of Newburgh - canine
645 Gidney Ave
Newburgh, NY 12550
(845) 561-3344

Printed: 08-05-13 at 12:03p
Date: 07-06-13
Account: 19984
Invoice: 552071

Date	For	Qty	Description	Price	Discount	Net Price
07-06-13	Marie	0000 1	CONSULT / EXAM - Sick	59.50	30.00	29.50 **
07-06-13		1	Pet Insurance Review			0.00
Please visit www.petinsurancereview.com and dogtime.com for an independent review of all national pet health insurance plans						

paid

Total charges, this invoice... 29.50

**Total discount included: 30.00

Your invoice total reflects our **13Stray Cat Accounts** discount.

LIKE US ON FACEBOOK.COM!

GOING AWAY?...BOOK YOUR PETS BOARDING RESERVATION TODAY!

In compliance with New York State law, all medications are non-refundable. We regret any inconveniences.

INVOICE

Newburgh Veterinary Hospital

1716 Route 300
Newburgh, NY 12550
845 564-2660

"Your pet is part of our family too." Visit us at www.newburghvet.com

FOR: Town of Newburgh - canine
645 Gidney Ave
Newburgh, NY 12550
(845) 561-3344

Printed: 08-05-13 at 12:15p
Date: 07-12-13
Account: 19984
Invoice: 552542

Date	For	Qty	Description	Price	Discount	Net Price
07-12-13	Raven Radziki	1	CANINE RABIES / 3 YEAR	25.00	12.50	12.50 **
Total charges, this invoice...						12.50
**Total discount included: 12.50						

Your invoice total reflects our **13Stray Cat Accounts** discount.

LIKE US ON FACEBOOK.COM!

GOING AWAY?....BOOK YOUR PETS BOARDING RESERVATION TODAY!

In compliance with New York State law, all medications are non-refundable. We regret any inconveniences.

INVOICE

Newburgh Veterinary Hospital

1716 Route 300
Newburgh, NY 12550
845 564-2660

"Your pet is part of our family too." Visit us at www.newburghvet.com

FOR: Town of Newburgh - canine
645 Gidney Ave
Newburgh, NY 12550
(845) 561-3344

Printed: 08-05-13 at 12:03p
Date: 07-18-13
Account: 19984
Invoice: 553005

Date	For	Qty	Description	Price	Discount	Net Price
07-09-13	Min Pin 7/9/13	1	CONSULT / EXAM - Annual Welln	49.50	24.75	24.75 **
07-09-13		1	Lyme,Hwt,Ehrlich Anaplasma 4Dx	72.50	36.25	36.25 **
07-09-13		1	Canine Dist/A2/PI/Parvo/Lepto1YR	25.00	12.50	12.50 **
Your pet has been vaccinated with Pfizer's new 5 in 1 DA2PPI , the best available protection against Distemper,Adenovirus, Parvovirus, Parainfluenza,and Leptosprosis						
07-09-13		1	CANINE RABIES / 1YEAR	25.00	12.50	12.50 **
07-09-13		1	Canine Respiratory Complex	25.00	12.50	12.50 **
Canine Kennel Cough is A HIGHLY contagious respiratory infection. Dogs can be exposed at any time through coughing or nose to nose contact. Boarding, grooming and or showing dogs can have incresased risk of exposure....please be sure to have your pet boosted every 12 months.						
07-09-13		1	4DX Elisa Negative			0.00
07-17-13	Paulette	1	CONSULT / EXAM - Sick	59.50	30.00	29.50 **
07-17-13		1	Pet Insurance Review			0.00
Please visit www.petinsurancereview.com and dogtime.com for an independent review of all national pet health insurance plans						
07-17-13		1	-MULTIPLE INJECTIONS	68.50	34.25	34.25 **
07-17-13		2	Famotidine 20 mg #170324	17.95	8.97	8.98 **
07-17-13		1	Veterinarian's Notes			0.00
07-17-13		1	Fel I/D 4#	19.99	9.99	10.00 **
07-17-13		4	Fel I/D can 5.5oz Can	6.68	3.34	3.34 **

Total charges, this invoice...

184.57

**Total discount included: 185.05

Your invoice total reflects our **13Stray Cat Accounts** discount.

LIKE US ON FACEBOOK.COM!

INVOICE

Newburgh Veterinary Hospital

1716 Route 300
Newburgh, NY 12550
845 564-2660

"Your pet is part of our family too." Visit us at www.newburghvet.com

FOR: Town of Newburgh - canine
645 Gidney Ave
Newburgh, NY 12550
(845) 561-3344

Printed: 08-09-13 at 12:43p
Date: 07-26-13
Account: 19984
Invoice: 553803

Date	For	Qty	Description	Price	Discount	Net Price
			Total charges, this invoice...			0.00
			Total payment(s) received...			175.00
			07-26-13 Cash payment (t.terbush)	175.00		_____

LIKE US ON FACEBOOK.COM!

GOING AWAY?....BOOK YOUR PETS BOARDING RESERVATION TODAY!

In compliance with New York State law, all medications are non-refundable. We regret any inconveniences.

INVOICE

Newburgh Veterinary Hospital

1716 Route 300
Newburgh, NY 12550
845 564-2660

"Your pet is part of our family too." Visit us at www.newburghvet.com

FOR: Town of Newburgh - canine
645 Gidney Ave
Newburgh, NY 12550
(845) 561-3344

Printed: 08-09-13 at 12:43p
Date: 08-07-13
Account: 19984
Invoice: 554844

Date	For	Qty	Description	Price	Discount	Net Price
08-07-13	Marie	-1	CONSULT / EXAM - Sick			-29.75
08-07-13		-1	Pet Insurance Review			0.00
Please visit www.petinsurancereview.com and dogtime.com for an independent review of all national pet health insurance plans						
Total charges, this invoice...						-29.75

LIKE US ON FACEBOOK.COM!

GOING AWAY?...BOOK YOUR PETS BOARDING RESERVATION TODAY!

In compliance with New York State law, all medications are non-refundable. We regret any inconveniences.

AUG 21 2013

10a

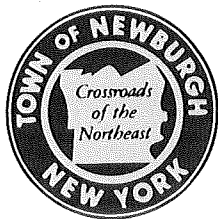

TOWN OF NEWBURGH RECREATION DEPARTMENT

311 ROUTE 32, NEWBURGH, NY 12550

Robert J. Petrillo
Commissioner of Parks, Recreation & Conservation

845-564-7815
FAX: 845-564-7827

July 30, 2013

TO: Wayne Booth, Supervisor
Town Board Members

FROM: Robert J. Petrillo, Commissioner

RE: Trolley Request

We are submitting for your approval the attached letter from the Coldenham Fire Company, Ladies Auxiliary, requesting the use of a trolley for the Montgomery Day Parade on Saturday, September 7th.

Thank you for your consideration.

Regards,

A handwritten signature in black ink, appearing to be 'R. Petrillo', written in a cursive style.

Robert J. Petrillo
Commissioner

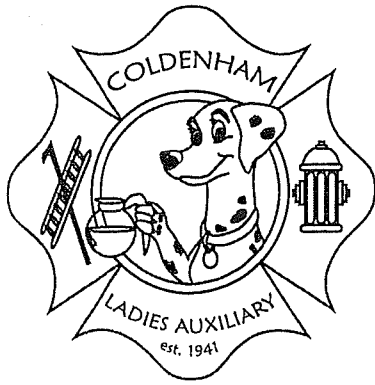

COLDENHAM FIRE COMPANY INC.
LADIES AUXILIARY
511 Coldenham Road
Walden, NY 12586
(845) 564-0438

June 26th, 2013

Newburgh Recreation Center
c/o Commissioner Robert Petrillo
311 Route 32,
Newburgh, NY 12550

Dear Commissioner Petrillo:

I am the Captain of the Coldenham Fire Department Ladies Auxiliary. When our department held their 75th Anniversary Parade our organization borrowed a trolley from the Recreation Center. We also borrowed a trolley for Montgomery Day parade in 2009, 2010, 2011 and 2012.

We were wondering if we could once again borrow the trolley to use in the Montgomery Day Parade, September 7, 2013. We have a number of ladies from our organization that would like to be in the parade but are unable to walk the distance. We have tried to acquire a trailer to decorate so that they could ride in the parade, but I haven't been able to.

Thanking you in advance for your time and consideration. Kindly let me know of your decision in this matter.

I can be reached at: Kathleen Gasperetti
444 Coldenham Road,
Walden, NY 12586
845-564-7882

Sincerely,

Kathleen J. Gasperetti
Captain,
Coldenham Fire Company Ladies Auxiliary

Kathleen J. Gasperetti

10.RECREATION:

- i. Trolley Request**
- ii. Hiring of Part Time Chauffer**

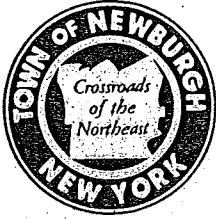

AUG 21 2013

TOWN OF NEWBURGH

1496 Route 300, Newburgh, New York 12550

108 Deb

PERSONNEL DEPT.

PH: 845-566-7785
Fax: 845-564-2170

To: Wayne C. Booth, Supervisor
Town Board Members

Cc: Jackie Calarco, Town Accountant

From: Charlene M. Black, Administrative Aide

Date: August 5, 2013

Re: Recreation

The attached application is for your review. The applicant, Robert W Taylor has been offered a job with the Recreation Department as a part time chauffeur starting September 12, 2013. The applicant's hiring is contingent on your approval and the completion of his fingerprints, paperwork, drug/alcohol screening and physical. Thank you in advance.

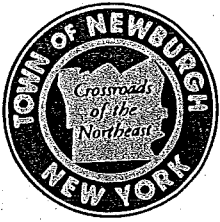

TOWN OF NEWBURGH RECREATION DEPARTMENT

311 ROUTE 32, NEWBURGH, NY 12550

Robert J. Petrillo
Commissioner of Parks, Recreation & Conservation

845-564-7815
FAX: 845-564-7827

July 25, 2013

TO: Wayne Booth, Supervisor
Town Board Members

CC: Charlene Black, Personnel

FROM: Robert J. Petrillo, Commissioner

RE: Hiring Part Time Chauffeur

I would like to request authorization to hire Mr. Robert W. Taylor as a part time chauffeur starting mid September. Hiring for this position will fill the vacant spot in the Recreation Department.

Mr. Taylor will be hired at the rate of \$12.00/hour. The salary for this position is in the budget under account 6773-0100.

Thank you for your consideration.

Regards,

Robert J. Petrillo
Commissioner

TOWN OF NEWBURGH

EMPLOYMENT REQUEST FORM

TO: PERSONNEL DEPARTMENT

NAME OF CANDIDATE: ROBERT W. TAYLOR

DEPARTMENT: RECREATION

TITLE OF POSITION: PART TIME CHAUFFEUR

FULL TIME OR PART TIME: PART TIME

HOURLY RATE: \$ 12.00

IS POSITION FUNDED IN CURRENT BUDGET: yes or no

FUND APPROPRIATION NUMBER: 6773-0100

PROPOSED HIRE DATE: 9/12/13

NOTE: CANDIDATE CANNOT BEGIN WORK WITHOUT PRE-EMPLOYMENT PHYSICAL AND COMPLETION OF ALL REQUIRED PAPERWORK.

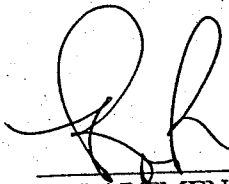

DEPARTMENT HEAD SIGNATURE

DATE 9/30/13

**ORIGINAL APPLICATION SHOULD BE ON FILE IN THE
PERSONNEL OFFICE.**

COPY TO ACCOUNTING DEPARTMENT
(02/05)

11.POLICE: Purchase of Equipment

AUG 21 2013



TOWN OF NEWBURGH POLICE DEPARTMENT

300 Gardnertown Road, Newburgh, New York 12550

Michael Clancy
Police Chief

(845) 564-1100

To: Town Board
From: Chief Michael Clancy
Subject: Request for equipment
Date: August 15, 2013

The Department is looking to purchase a GPS Tracking Device which attaches to a vehicle whose driver is the target of narcotics investigations or other criminal investigations. Our Detectives have borrowed tracking units in the past and installed them on vehicles pursuant to a court orders. The use of a tracker enables investigators to obtain constant location data on a vehicle for long periods of time while greatly reducing the number of man-hours spent on surveillances.

In one recent case, detectives placed a borrowed GPS tracker on the car of a person suspected in several burglaries. After several days of collecting location data from the tracker, the suspect was connected to reported thefts in the Town as well as in New Windsor. He was subsequently arrested. Without the use of the tracker, following this suspect over several days and nights would have required several investigators and many hours of overtime. In addition, trackers have been used in several of our narcotics cases. It could also be used for sensitive internal investigations.

I ask that we be allowed to purchase a Stealth 2 GPS Tracker at a total price of \$1,565. The price includes one year of airtime for GPS mapping as well as shipping and handling. Funding for the purchase would come out of the drug seizure account. Monies in that account have all come from assets seized during narcotics investigations. After one year, cost of airtime would also be paid from the seizure account.

Thank you for your time and consideration.

CovertTrack Group, Inc.

CovertTrack Group, Inc.
8361 E Gelding Dr.
Scottsdale, AZ 85260

(480)661-1916
admin@gpsintel.com
http://www.covertrackgroup.com

Estimate

Date	Estimate #
07/11/2013	2902
Exp. Date	

Address
Newburgh PD (NY) 300 Gardner Town Rd. Newburgh, NY 12550

Ship Via	Sales Rep
UPS Ground	Bill

Activity	Quantity	Rate	Amount
• Stealth 2 GPS tracking device	1	950.00	950.00
• Airtim e-1 year with unlimited 5 second tracking and mapping service	1	600.00	600.00
• Shipping and Handling of product to customer	1	15.00	15.00
Total			\$1,565.00

- ***Three Easy Ways to Order***
 1. Sign and fax to (480) 451-5421.
 2. Sign, scan, & email back.
 3. Call with credit card: (480) 661-1916.

Accepted By _____

Accepted Date _____

COVERTTRACK®

STEALTH II GPS TRACKER

New!
GPS
Warrant Tracking
Patent Pending

The STEALTH II GPS Tracker is the newest innovation in vehicle surveillance from CovertTrack©. Designed exclusively for law enforcement, the STEALTH II is simply the most cost-effective, covert tracking device available.

Now Featuring GPS Warrant Tracking (Patent pending) - A new, indispensable tracking feature that enables law enforcement to simply and effectively employ GPS tracking in compliance with search warrant parameters. With GPS Warrant Tracking, tracking is enabled for the duration of your warrant only. **Don't limit your GPS tracking! Control it with GPS Warrant Tracking!**

Features

- ▶ 30+ Day Battery Life
- ▶ Simple-to-use Web-Based Mapping System
- ▶ Made Exclusively for Law Enforcement
- ▶ Locate Anytime Ability
- ▶ Covert Casing
- ▶ Tamper Alert Switch
- ▶ 24/7/365 Technical Support
- ▶ New! GPS Warrant Tracking

Specifications

Internal 10.4 Amp Hour Rechargeable Battery

IP67 Weatherproof Housing

Internal Antennas

Motion Sensor - TTF
- Cold Start 35 sec average
- Hot start < 1.2 sec

Frequency - Quad Band:
850/900/1800/1900 MHz

FCC Certified

Ublox 6 GPS Chip
-160dBm Tracking
-147dBm Cold Start

Anti-Jamming Technology

High Performance GPS
over 2 million correlators

Magnetic or Zip-Tie Attachable

Mapping

Address Reports

REP Area Exclusion Zones

Satellite Mapping

Stop Reports

Geo-Fence Alerts

SMS & Email Alerts

No Software to Install

Trackable by Cell Phone

DOD Compliant Hosting Environment

Worldwide Coverage Available

Low Price

Only \$950 / Stealth II Unit (qty discounts available)

\$600/year Mapping Service

- Unlimited 5 Second Updates

- Cellular Tower Fix Data Included

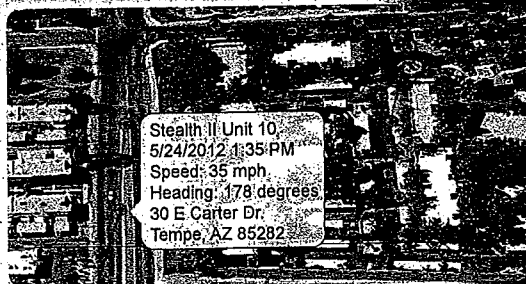
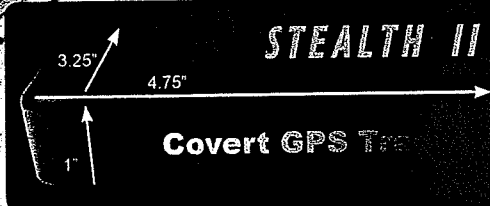

Secure GPS tracking on any computer or pda-style cell phone

FREE 2-Week Demo

Call (480) 661-1916

Bill Barendrick - SouthEast Sales Manager (480) 661-1916 SouthEastSales@gpsintel.com

CovertTrack Group, Inc. 9393 N. 90th St., Suite 108-B Scottsdale, AZ 85258 (480) 661-1916 gpsintel.com

12.ASSESSOR: Hiring of Auditor



300 Westage Business Center Drive | Suite 403
Fishkill, New York 12524
Phone: 845-765-0705 | Fax: 845-765-0706
www.dayseckler.com

July 22, 2013

Hacker Murphy, LLP
Attn: Cathy Drobny
7 Airport Park Boulevard
Latham, NY 12110

Dear Ms. Drobny:

We are pleased to confirm our understanding of the nature and limitation of the services we are to provide Hacker Murphy, LLP in your capacity as legal counsel to the Town of Newburgh with respect to the Statement Income and Expense report of the Hampton Inn, Newburgh (the "Hampton"). The services Day Seckler, LLP performs hereunder will be solely for Hacker Murphy, LLP, in your capacity as legal counsel to the Town of Newburgh.

We will apply the agreed-upon procedures which Hacker Murphy, LLP has specified, listed in the attached Exhibit A, to the Statement of Income and Expenses of the Hampton Inn, Newburgh for the years ending December 31, 2010, 2011 and 2012. This engagement is solely to assist Hacker Murphy, LLP in determining the appropriate reporting of expenses for the Hampton.

Our engagement to apply agreed upon procedures will be conducted in accordance with U.S. generally accepted auditing standards, which incorporate the financial audit and attestation standards established by the American Institute of Certified Public Accountants (the "AICPA"). The sufficiency of the procedures is solely the responsibility of Hacker Murphy, LLP. Consequently, we make no representation regarding the sufficiency of the procedures described in Exhibit A either for the purpose for which this report has been requested or for any other purpose. If, for any reason, we are unable to complete the procedures, we will describe any restrictions on the performance of the procedures in our report, or will not issue a report as a result of this engagement.

Because the agreed-upon procedures listed in Exhibit A do not constitute an audit as defined under U.S. generally accepted accounting principles, we will not express an opinion on the Hampton financial report or any elements, accounts, or items thereof. In addition, we have no obligation to perform any procedures beyond those listed in Exhibit A.

We will submit a report listing the procedures performed and our findings. This report is intended solely for the use of Hacker Murphy, LLP and should not be used by anyone else. Our report will contain a paragraph indicating that had we performed additional procedures under Generally Accepted Accounting Principles, other matters might have come to our attention that would have been reported to you.

You are also responsible for making all management decisions and performing all management functions; for designating an individual with suitable skill, knowledge, and/or experience to oversee the services we provide; and for evaluating the adequacy and results of those services and accepting responsibility for them.

We plan to begin our procedures on approximately August 6, 2013 and, unless unforeseeable problems are encountered, the engagement should be completed by September 30, 2013.

Our fees for the above services will be billed at our hourly rates set forth below. We will also be reimbursed for our reasonable out-of-pocket expenses including, but not limited to, costs of reproduction, typing, our legal counsel, travel and other direct expenses. At this time we expect our out-of-pocket expenses will be minimal. If that should change, we will notify you in advance. Our current hourly rates are as follows:

Partner	\$ 225
Professional Staff	\$ 125- \$175
Support Staff	\$ 95

We estimate that our fees for these services will be between \$5,000 and \$6,000. If the scope of our work efforts is reduced from Exhibit A, we will bill only for those services performed at the above hourly rates. The fee estimate is based on anticipated cooperation from the Hampton's personnel and the assumption that unexpected circumstances will not be encountered during the engagement. If significant additional time is necessary, we will discuss it with you and arrive at a new fee estimate before we incur the additional costs. We will require a retainer of \$3,000 before we begin with the balance due when we issue our report. If our fees incurred are less than the retainer, we will return the unused amount to you.

We confirm that no partner or member of our staff has any financial interest or business connection with the Association nor are we aware of no conflicts in connection with this engagement.

We appreciate the opportunity to assist you and believe this letter accurately summarizes the significant terms of our engagement. If you have any questions, please let us know. If you agree with the terms of our engagement as described in this letter, please sign below and return this letter to us.

If the need for additional procedures arises, our agreement with you will need to be revised. It is customary for us to enumerate these revisions in an addendum to this letter. If additional specified parties of the report are added, we will require that they acknowledge in writing their responsibility for the sufficiency of the procedures.

Hacker Murphy, LLP
July 22, 2013
Page 3

Very truly yours,

Day Seckler LLP

Day Seckler LLP
Certified Public Accountants and Consultants

Accepted By:

Signature

Title

Date

Exhibit A
Agreed-Upon Procedures to be Performed

We will perform the following procedures for the Room Expenses, G&A Expense, and Repairs & Maintenance accounts listed on the Statement of Income and Expenses Reports for the periods ending December 31, 2010, 2011 and 2012:

1. Review accounts contained within the above categories
2. Select accounts for testing
3. Review detailed general ledger report for accounts selected for testing
4. Select individual transactions from the detailed general ledger report for testing
5. For the items selected for testing we will:
 - a. Trace the amounts to the vendor invoices and supporting documentation
 - b. Examine invoice and supporting documentation to determine whether the transaction has been reported appropriately
 - c. Inquire if the item appears unusual or questionable
 - d. Trace the amount to the Cash Disbursement Journal
 - e. Trace amount paid to the bank statement
 - f. Review cancelled checks to ensure payment was made to the correct vendor
 - g. Trace amounts reported to applicable payroll tax returns
6. Agree the net income (loss) per the Statement of Income and Expenses Report to the Company's federal income tax returns.

CIRCULAR 230 NOTICE - Pursuant to applicable regulations promulgated by the United States Department of the Treasury which govern the practice of tax professionals before the Internal Revenue Service, please be advised that any tax advice which may be contained within either this electronic communication or any document attached to this electronic communication and which concludes at a confidence level of at least more likely than not, that one or more significant Federal tax issues addressed herein will be resolved in the taxpayer's favor, is not being rendered by the author of such advice for the purpose of you relying upon said advice as a basis for a claim of the existence of "substantial authority" so as to avoid the imposition of any penalties which may be assessed by the Internal Revenue Service as a result of your reliance upon such advice.

CONFIDENTIALITY NOTICE - Rider, Weiner & Frankel, P.C.: This electronic message is intended to be viewed only by the individual or entity to whom it is addressed. It may contain information that is privileged, confidential and exempt from disclosure under applicable law. Any dissemination, distribution or copying of this communication is strictly prohibited without our prior permission. If the reader of this message is not the intended recipient, or the employee or agent responsible for delivering the message to the intended recipient, or if you have received this communication in error, please notify us immediately by return e-mail and delete the original message and any copies of it from your computer system.

13. PUBLIC ENTERTAINMENT PERMIT APPLICATION

AUG 21 2013

13

RECEIVED
AUG 05 2013
TOWN OF NEWBURGH
TOWN CLERK'S OFFICE

PUBLIC ENTERTAINMENT PERMIT APPLICATION

Date: AUG 3 2013

Applicant's name and address: ANGELA CALLAHAN
0 10 CLEARMONT LAKE
MONTGOMERY NY 12549

Sponsor's name and address: EAST COLDENHAM ELEMENTARY
SCHOOL PTA
286 STATE RT 17K NEWBURGH NY 12550

**Sponsor's qualification
(Check all that apply):**

- Sponsor is a local religious, fraternal, educational, political, veterans, firemen's, civic, nonprofit or charitable organization that has an office or place of operation or owns real property in the Town of Newburgh;
- has at least ten (10) members who are residents or have places of operation in the Town of Newburgh;
- regularly holds its meetings and conducts its activities at a site in the Town of Newburgh;
- provides services to residents of the Town of Newburgh

Explain:

**Sponsor's officers and directors
names and addresses:**

ANGELA CALLAHAN EAST COLDENHAM PTA
10 CLEARMONT LA
MONTGOMERY NY 12549
PAM WEINSTEIN
286 STATE RTE 17K
NEWBURGH NY 12550

CHRISTINE FANNER
286 STATE RTE 17K
NEWBURGH NY 12550

(attach additional sheet if necessary)

Nature of the Activities

CARNIVAL - Rides, Games, Food

This will be our 4TH CARNIVAL AT MALL

Admission fee (if any):

\$ None

Expected Maximum No. of Attendees at one time:

400

Expected Maximum No. of Vehicles at one time:

120

Method of disposing of refuse:

Sanitation company - STREET Sweeper

Will private security guards or police be engaged; if so, the number and their duties:

Newburgh Police

Fire Protection Precautions: Extinguishers in Generators
Egress for safety

Applicant's Signature:

Printed Name:

Robert F. Desjardins Jr

Title:

Date:

AUG 3, 2013

Sponsor's Signature:

Printed Name:

Angela Callahan

Title:

EAST COLDENHAM ELEMENTARY PTA

Date:

8/5/2013

If Sponsor does not have office in Orange County, name and address of natural person in Orange County agreeing to accept service of process:

Required:

(attach agreement to act as agent for service of process)

Name, age, address and telephone # of individual in charge of the function for the Sponsor:

Dreamland Amusements
2 Olympia LA
Stony Brook NY 11790
Bob DeStefano 516-901-2988

Address, Section, Block and Lot of property at which function is to be held:

Newburgh Mall

Section ___ Block ___ Lot ___
(attach copy of tax map)

Amusement Company's name and address:

Same as above

Dates and hours of function:

(Applications must be submitted at least 30 days prior to Commencement Date)

Commencement Date: SEPT 5, 2013
Termination Date: SEPT 8, 2013
Hours: 1PM - 11PM

Purpose of the function;

Actual Police Protection Costs \$ _____

Chief's or Designee's initials Date

Code Compliance Department Certificate of Discharge:

*Date and time of
inspection
following event:*

Signature of Code Compliance Department Officer

Insurance Certificate evidencing \$ _____ \$ _____ additional
liability insurance coverage

Other requirements imposed by Town Board: _____

Name and telephone number of
contact person for additional
requirements:

Internal Use Only

Date application
received: _____

Reviewed and Found Complete: _____

Town Clerk's signature

Date: _____

To Be Completed Prior to Application's Submission to Town Board:

Police Department
Approval of Security,
Traffic Control and
Parking Plans

Signature

Date

Estimated Costs of
Additional Police
Protection for Event \$ _____

Chief's or Designee's Initials

Town Board Approval

Date: _____

Conditions:

1. \$ _____ payment for reimbursement of costs of police protection prior to issuance of permit
2. Other conditions (if any): _____

Signature of Town Supervisor

Date

To Be Completed Following Event:



February 27, 2013

Mr. Andrew J. Zarutskie, Town Clerk
Town of Newburgh
1496 Route 300
Newburgh, NY 12550

**Re: Dreamland Amusements (C/o Kevaworks, Inc.)
September 2013 Carnival Event at Newburgh Mall**

Dear Mr. Zarutskie:

Dreamland Amusements has permission to apply for the necessary permits to host a carnival at Newburgh Mall. The dates for the event are Sept. 5, 2013 – Sept. 8, 2013.

Please contact me with any questions as we look forward to having this wonderful event again at Newburgh Mall.

Regards,
URBAN RETAIL PROPERTIES, LLC
As Agent for Newburgh Mall

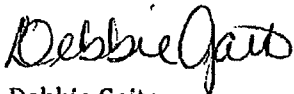

Debbie Gaito
Specialty Leasing Representative
Direct Phone: (845) 566-4130
Email: GaitoD@urbanretail.com

Cc. Craig Herkimer, Kevaworks, Inc.

14. STORAGE CONTAINER LOCAL LAW: Review

14

Dickover, Donnelly, Donovan & Biagi, LLP
Attorneys and Counselors at Law

James B. Biagi
David A. Donovan
Michael H. Donnelly
Robert J. Dickover

28 Bruen Place
P.O. Box 610
Goshen, NY 10924
Phone (845) 294-9447
mail@doddblew.com
Fax (845) 294-6553
(Not for Service of Process)

Successor Law Firm To:
Alexander Appelbaum, P.C., Florida, N.Y. (1915-1988)
Ludmerer & Vurno, Esqs., Warwick, N.Y.

August 8, 2013

Town of Newburgh Town Board
1496 Route 300
Newburgh, New York 12550

RE: Cargo Storage Container Local Law

Members of the Board:

The planning board took up consideration of the above referenced local law during its meeting of July 18, 2013 and August 1, 2013. The planning board has authorized me to prepare this letter constituting the planning board's report pursuant to Section 185-60 of the Code of the Town of Newburgh.

Section 185-60(B)(1)(a): Whether such change is consistent with the aims and principles embodied in the Chapter as to the particular districts concerned.

The allowance for cargo storage containers in certain commercial districts, together with a prohibition on the permanent use of such containers in residential districts, is generally consistent with the aims and principles of the zoning chapter. However, some of the new screening requirements appear to overlap the outdoor storage [185-30] provisions that currently exist in the zoning chapter. For instance, in the proposed Section 185-15.1(E)(2), cargo storage containers are required to be setback 20 feet from any side or rear lot line. Section 185-30(A)(2) requires that the outdoor storage of materials or products requires that such storage be setback 10 feet from any side or rear lot line and 50 feet from a side or rear lot line adjacent to a residence district or lot in residential use. Further, the vegetative screening requirement of proposed Section 185-15(E)(7) is different than the "opaque site barrier" requirement of Section 185-30(A)(3). While the opening section of 185-30(A)

does announce that its provisions stand down when other provisions are set forth in the chapter, and while 185-30 relates more specifically to outdoor storage of motor vehicles, trailers, building supplies, raw materials, finished products, machinery and equipment, some careful review should take place to see whether the setback and screening requirements of the sections should be consistent. The planning board recommends adoption of the opaque barrier provisions of Section 185-30 rather than the vegetative screening requirements of the current draft of the local law.

The planning board notes that the draft local law allows cargo containers in residential zones on a temporary (30-day maximum) basis. The planning board recommends that this allowance be both expanded and narrowed. Specifically, the planning suggests that only “pod” style cargo containers (containers designed for storage only, having no wheels and being placed flush to the ground) be allowed in residential zones. Simultaneously, the planning board recommends that the allowance be expanded to a maximum of 90 days. Certain members have given examples of temporary storage of personal items during reconstruction following a fire or other major reconstruction project as likely requiring storage for a period far in excess of 30 days. In order to track duration of use—and to make enforcement manageable—the planning board also recommends that a permit be required (but not site plan review) for placement of cargo storage containers on residential property.

Section 185-60(B)(1)(b): Which areas and establishments in the Town will be directly affected by such change and in what way they will be affected.

At the present time, the planning board is aware only of the *Nella's Nest* application. However, it is possible that other applicants may request storage trailers on their sites, for instance medical offices in the IB Zoning District [Use D5], professional offices in the I District [Use D1] and the assortment of uses permitted within business parks in the I District [Use D12], as well as those same uses in the B District [Uses D2 and D11]. Similarly the LHI Overlay District, allowing the sale, service and repair of light and heavy industrial equipment may result in applications for cargo storage trailers in the various areas where that overlay district can land.

Section 185-60(B)(1)(c): The indirect implications of such change and its effects on other regulations.

Other than the potential inconsistencies between the provisions of proposed Section 185-15.1 and Section 185-30, the planning board does not perceive any significant indirect impacts from enactment of this local law.

Section 185-60(B)(1)(d): Whether such amendment is consistent with the aims of the Master Plan

The planning board finds that the local law's proposed amendments are consistent with the Master Plan and the town's design guidelines..

Very truly yours,

A handwritten signature in black ink, appearing to read "MHD", with a large, stylized flourish extending downwards and to the right.

MICHAEL H. DONNELLY

MHD/lrm

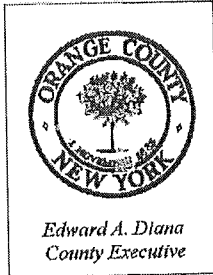

ORANGE COUNTY DEPARTMENT OF PLANNING

DAVID CHURCH, AICP
COMMISSIONER

www.orangecountygov.com/planning
planning@orangecountygov.com

124 MAIN STREET
GOSHEN, NEW YORK 10924-2124

TEL: (845) 615-3840
FAX: (845) 291-2533

County Reply – Mandatory Review of Local Planning Action as per NYS General Municipal Law §239-l, m, &n

Local Referring Board: Town of Newburgh Town Board

Referral ID #: NBT29-13M

Applicant: Robert's Contracting (Nella's Nest)

Tax Map #: N/A

Proposed Action: Zoning amendment permitting cargo storage containers as accessory uses.

Local File #: N/A

Reason for County Review: Adoption of a Local Law which affects planning and/or zoning within 500 feet of State and County highways and municipal boundaries.

Date of Full Statement: June 26, 2012

Comments:

County Planning is in receipt of the GML §239 referral for the above referenced Local Law. Based upon our review of the submitted materials, our office has found no evidence that significant inter-municipal or county-wide impacts would result from its approval. Our office would like to include the following as advisory comments:

1. Proposed section 185-15.1(C) limits the time period to thirty (30) days in which temporary containers are permitted on a residential zoned property or on property with a primary use of which is residential. County Planning recommends the Board take into account those instances related to people moving in and out of a home. These types of container are popular for DIY moving, which with one family moving out and another family moving in has the potential of taking longer than thirty (30) days.

Another instance is during potential renovations to a home. These types of container are popular with contractors as mobile work centers, usually for tool and material storage during construction. Section 185-15.1(D) allows contractors to utilize these containers, yet our interpretation is that they would be subject to the same thirty (30) day time period.

With both instances a case by case analysis may be required in order to allow the temporary

containers longer than thirty (30) days outlined in the Local Law.

County Recommendation: Local Determination

Date: June 3, 2013

**Prepared by: Chad M. Wade, R.L.A.
Planner**

A handwritten signature in black ink, consisting of several loops and a horizontal line at the bottom, positioned above the printed name and title.

**David Church, AICP
Commissioner of Planning**

As per NYS General Municipal Law 239-m & n, within 30 days of municipal final action on the above referred project, the referring board must file a report of the final action taken with the County Planning Department. For such filing, please use the final action report form attached to this review or available online at www.orangecountygov.com/planning.

**INTRODUCTORY LOCAL LAW #__ OF 2013
A LOCAL LAW AMENDING CHAPTER 185 ENTITLED
“ZONING”
OF THE CODE OF THE TOWN OF NEWBURGH
TO ADD CARGO STORAGE CONTAINERS AS A
PERMITTED ACCESSORY USE TO CERTAIN USES
IN THE B, IB AND I DISTRICTS
AND THE LHI OVERLAY DISTRICT
AND TO ADD STORAGE BUILDINGS AS A
PERMITTED ACCESSORY USE TO
OFFICES FOR BUSINESS, RESEARCH AND PROFESSIONAL USES
IN THE IB DISTRICT**

BE IT ENACTED by the Town Board of the Town of Newburgh as follows:

SECTION 1 – TITLE

This Local Law shall be referred to as “A Local Law Amending Chapter 185 entitled ‘Zoning’ of the Code of the Town of Newburgh to add Cargo Storage Containers as a Permitted Accessory Use to Certain Uses in the B, IB and I Districts and the LHI Overlay District and to add Storage Buildings as a Permitted Accessory Use to Offices for Business, Research and Professional Uses in the IB District”.

SECTION 2 – PURPOSE AND INTENT

The purpose of this local law is to regulate the use of cargo containers for storage on properties in the Town, which regulations are adopted to protect the public health, safety, and welfare, and to promote convenience, economy, aesthetics and the general welfare of the Town. The Town Board declares its intent to regulate the use of Cargo Containers for storage on properties in the Town

SECTION 3 – AMENDMENTS TO CHAPTER 185

1. Section 185-3 entitled “Definitions; word usage” is hereby amended by the addition of the following definition:

“CARGO CONTAINER - a standardized reusable metal vessel that was:

1. Originally designed for or used in the packing, shipping, movement or transportation of freight, articles, goods or commodities; and/or

2. Originally designed for or capable of being mounted or moved by rail, truck or ship by means of being mounted on a chassis or similar transport device. This definition includes the terms “transport containers” and “portable site storage containers” having a similar

appearance to and similar characteristics of cargo containers.

For purposes of this chapter, cargo containers originally built for purposes other than the storage of goods and materials are not accessory buildings.”

2. A new Subsection 185-15.1 entitled “Cargo Container Use for Storage” is hereby added to Chapter 185 to read as follows:

“§ 185-15.1 Cargo Container Use for Storage.

A. Permitted Locations. The placement of a cargo container as an accessory storage use is limited to the following zoning districts and overlay district:

1. Business (B).

2. Interchange Business (IB).

3. Industrial (I).

4. Light and Heavy Industrial Equipment and Recreational Vehicle Sales, Service and Repair Overlay (LHI)

The placement of cargo containers for storage is further limited to lots in the above-identified zoning districts only if the lot upon which the cargo container is proposed to be located falls within a use classification in the applicable Table of Use and Bulk Requirements for which cargo storage container is identified as a permitted accessory use and does not contain an accessory storage building.

B. Cargo containers are not permitted to be used for accessory storage on property zoned residential or on property the primary use of which is residential.

C. Notwithstanding the provisions set forth in subsection B of this section, the temporary placement of transport containers and/or portable site storage containers on residentially zoned properties, or on properties the primary use of which are residential, for the limited purpose of loading and unloading household contents shall be permitted for a period of time not exceeding 30 days in any one calendar year.

D. Notwithstanding the provisions set forth in subsection A and B of this section,

contractors may use cargo containers for the temporary location of equipment and/or materials storage structure during construction which is taking place on the property where the cargo container is located.

E. A permitted accessory cargo storage container may be located in any required side or rear yard provided that:

1. Such cargo storage container shall not exceed 15 feet in height
2. Such cargo storage container shall be set back at least 20 feet from any side or rear lot line and at least 10 feet from the main building.
3. Such cargo storage container shall not occupy more than 10% of the required yard area in which it is proposed to be situated.
4. A maximum of one (1) cargo storage container shall be permitted on each lot.
5. Accessory cargo storage containers shall have a maximum of 500 square feet of floor area.
6. Yards having a line bounding on the right of way of Interstate 87 or Interstate Route 84 shall not be considered front yards for purposes of this §185-15.1
7. Vegetative screening at least 10 feet in width shall be provided between the cargo storage container and any side or rear lot line within 50 feet of the container and vegetative screening or a barrier shall be installed to prevent the container from being visible from any bounding street right of way.
8. A solid, firm base surface shall be provided for the cargo storage container capable of sustaining the load of the cargo storage container and its contents.

F. Nothing herein shall be construed to restrict the use of cargo containers for agricultural operations.”

3. The Table of Use and Bulk Requirements for the B District-Schedule 7 as referenced by Section 185-10 “Utilization of Use Table” is hereby amended to add the following to Column A “Accessory Uses” and Column B “Permitted with”:

A. Accessory Uses
“18. Cargo storage containers
in accordance with §185.15.1”

B. Permitted with:
“D2 and 11”

4. The Table of Use and Bulk Requirements for the IB District-Schedule 8 as referenced by Section 185-10 “Utilization of Use Table” is hereby amended to add the following to Column A “Accessory Uses” and Column B “Permitted with”:

A. Accessory Uses
“18. Cargo storage containers
in accordance with §185.15.1”

B. Permitted with:
“C1, D5, 7, 11 and 13”

5. The Table of Use and Bulk Requirements for the I District-Schedule 9 as referenced by Section 185-10 “Utilization of Use Table” is hereby amended to add the following to Column A “Accessory Uses” and Column B “Permitted with”:

A. Accessory Uses
“13. Cargo storage containers
in accordance with §185.15.1”

B. Permitted with:
“D1, 2, 3, 10 and 12”

6. The Table of Use and Bulk Requirements for the LHI District-Schedule 7A as referenced by Section 185-10 “Utilization of Use Table” is hereby amended to add the following to Column A “Accessory Uses” and Column B “Permitted with”:

A. Accessory Uses
“3. Cargo storage containers
in accordance with §185.15.1”

B. Permitted with:
“D1”

7. The Table of Use and Bulk Requirements for the IB District-Schedule 8 as referenced by Section 185-10 “Utilization of Use Table” is hereby additionally amended to add “D5”, the use classification for “Offices for business, research and professional use” to Column B “Permitted with” for item 1 “Storage buildings up to 50% of the floor area of the principal building” as follows:

A. Accessory Uses
“1. Storage Buildings up to 50% of
the floor area of the principal building”

B. Permitted with:
“C1, D5, 7, 11 and 13”

SECTION 5 – VALIDITY

If any word, clause, sentence, paragraph, section or part of this local law or the application thereof to any person or circumstance shall be adjudged by any court of competent jurisdiction to be unconstitutional, illegal or invalid, such judgment shall not affect, impair or invalidate the remainder thereof or the application thereof to any other persons or circumstances but shall be confined in its operation to the clause, sentence, paragraph, word, section or part thereof directly involved in the controversy in which such judgment shall have been rendered. The Town Board hereby declares that it would have enacted this Local Law or the remainder thereof if the invalidity of such provision or application thereof had been apparent.

SECTION 6 – EFFECTIVE DATE

This Local Law shall take effect immediately when it is filed in the Office of the New York State Secretary of State in accordance with Section 27 of the Municipal Home Rule Law.

Dickover, Donnelly, Donovan & Biagi, LLP
Attorneys and Counselors at Law

James B. Biagi
David A. Donovan
Michael H. Donnelly
Robert J. Dickover

28 Bruen Place
P.O. Box 610
Goshen, NY 10924
Phone (845) 294-9447
mail@dddblaw.com
Fax (845) 294-6553
(Not for Service of Process)

Successor Law Firm To:
Alexander Appelbaum, P.C., Florida, N.Y. (1915-1988)
Ludmerer & Vurno, Esqs., Warwick, N.Y.

August 20, 2013

Wayne C. Booth, Supervisor
Town of Newburgh Town Board
1496 Route 17K
Newburgh, New York 12550

RE: Proposed Town of Newburgh Local Law Amending Chapter 185 entitled "Zoning" of the Code of the Town of Newburgh to add a Cargo Storage Containers as Permitted Accessory Use to Certain Uses in the B, IB and I Districts and the LHI Overlay District and to Add Storage Buildings as a Permitted Accessory Use to Offices for Businesses, Research and Professional Uses in the IB District (Application of Nella's Nest)

Dear Supervisor Booth and Town Board Members:

I write to you in my capacity as counsel for the Town of Newburgh Zoning Board of Appeals in response to the letter of Town Attorney Mark Taylor, Esq., dated June 24, 2013 which referred the above referenced proposed local law to the Zoning Board for review and report.

Based upon the Zoning Board's review, I report to you as follows.

The Zoning Board discussed the proposed local law at length. As a result of those discussions, the following areas of concern were identified:

1. There appears to be no restriction as to the size of the storage container. The Zoning Board is concerned that large containers would be a detriment to the surrounding neighborhood and suggest, therefore, that a size limitation of 320 square feet be imposed;
2. The Zoning Board would like to see that any storage container utilized be

compatible in terms of architectural style and color with the main building on the property;

3. The Zoning Board believes there should be a specific time frame regarding the placement of the storage container and suggest that that time frame be six months with the ability to obtain an extension for good cause shown;
4. The Zoning Board believes that the 15-foot maximum height of the container is excessive and suggest something less obtrusive;
5. The Zoning Board further recommends that there be no attachments or "lean-tos" that would be affixed to the storage container.

The foregoing constitutes the review and report of the Zoning Board of Appeals of the Town of Newburgh.

Very truly yours,

A handwritten signature in black ink, appearing to read "DAVID A. DONOVAN". The signature is stylized and somewhat cursive.

DAVID A. DONOVAN

Cc: Grace Cardone, Zoning Board Chair
Mark Taylor, Esq., Town Attorney

Specifications	10' Container	20' Container	40' Container
Inside Cubic Capacity	15.4 m ³	33.2 m ³	67 m ³
Max Gross Weight	non payload	30,480 kg	30,480 kg
Tare Weight	1,500 kg	2,360 kg	3,980 kg

Dimensions	Length	Width	Height
10' External	3.10 m (10')	2.44 m (8')	2.59 m (8'6")
10' Internal	2.98 m	2.35 m	2.38 m
20' External	6.05 m (20')	2.44 m (8')	2.59 m (8'6")
20' Internal	5.90 m	2.35 m	2.38 m
40' External	12.19 m (40')	2.44 m (8')	2.59 m (8'6")
40' Internal	12.01 m	2.35 m	2.38 m
Door Size		2.34 m	2.28 m

Specifications	20' General Purpose Container	40' General Purpose Container
Inside Cubic Capacity	33.2 m ³	67 m ³
Max Gross Weight	30,480 kg	30,480 kg
Tare Weight	2,350 kg	3,950 kg

Dimensions	Length	Width	Height
20' External	6.05 m (20')	2.44 m (8')	2.59 m (8'6")
20' Internal	5.90 m	2.35 m	2.50 m
40' External	12.19 m (40')	2.44 m (8')	2.59 m (8'6")
40' Internal	12.01 m	2.35 m	2.50 m
Door Size		2.34 m	2.28 m

Size	Door openings*		Internal dimensions*			Weight*			Volume* m3 cubic feet	Material					
	mm	feet/inches	mm	feet/inches	mm	feet/inches	kg/lb	Max. gross			Tare	Max. payload			
20 std	2340	7' 8 1/16"	2274	7' 5 1/2"	5.896	19' 4 1/16"	2.350	7' 8 1/2"	2.393	7' 9 7/8"	30.480	2.280	28.200	33	Steel
20' x 8' x 8' 6"	7' 8 1/16"	7' 5 1/2"	19' 4 1/16"	7' 8 1/2"	7' 9 7/8"	67.200	5.030	62.170	1.179						
40 std	2340	7' 8 1/16"	2274	7' 5 1/2"	12.032	39' 5 13/16"	2.350	7' 8 1/2"	2.393	7' 10 3/16"	32.500	3.700	28.800	67	Steel
40' x 8' x 8' 6"	7' 8 1/16"	7' 5 1/2"	39' 5 13/16"	7' 8 1/2"	7' 10 3/16"	71.650	8.157	63.493	2.390						
40 high	2340	2577	12.032	2.350	2.697	32.500	3.880	28.620	76						Steel
40' x 8' x 9' 6"	7' 8 1/16"	8' 5 7/16"	39' 5 13/16"	7' 8 1/2"	8' 10 3/16"	71.650	8.550	63.100	2.700						
45 high	2340	2584	13.582	2.347	2.696	32.500	3.900	28.600	86						Aluminium
45' x 8' x 9' 6"	7' 8 3/8"	8' 5 11/16"	44' 6 11/16"	7' 8 3/8"	8' 10 1/8"	71.650	8.600	63.050	3.071						
45 high	2340	2585	13.556	2.352	2.697	32.500	4.900	27.600	86						Steel
45' x 8' x 9' 6"	7' 8 3/8"	8' 5 3/4"	44' 5 11/16"	7' 8 9/16"	8' 10 3/16"	71.650	10.800	60.850	3.040						

**15.RESOLUTION to Schedule Public Hearing for Tax Levy Cap Local
Law**

AUG 21 2013

13

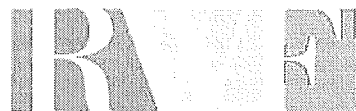

Rider Weiner & Frankel P.C.
ATTORNEYS & COUNSELORS AT LAW

MEMORANDUM

TO: HON. WAYNE C. BOOTH, SUPERVISOR
TOWN BOARD MEMBERS

FROM: MARK C. TAYLOR, ATTORNEY FOR THE TOWN

RE: LOCAL LAW TO OVERRIDE THE TAX LEVY LIMIT
OUR FILE NO. 800.1(B)() (2013)

DATE: AUGUST 15, 2013

P: 845.562.9100
F: 845.562.9126

655 Little Britain Road
New Windsor, NY 12553

P.O. Box 2280
Newburgh, NY 12550

Enclosed please find the following draft resolution for the Board's consideration:

Resolution of Town Board Introducing Local Law to Override the Tax Levy Limit Established in General Municipal Law 3-C and Providing for Public Notice and Public Hearing.

Also enclosed is a copy of the proposed Introductory Local Law.

ATTORNEYS

David L. Rider
Charles E. Frankel
Michael J. Matsler
Mark C. Taylor
Deborah Weisman-Estis
M. Justin Rider
Shay A. Humphrey
Jeffrey S. Sculley
Donna M. Badura
Darren H. Fairlie

M. J. Rider
(1906-1968)

Elliott M. Weiner
(1915-1990)

COUNSEL

Stephen P. Duggan, III

OF COUNSEL

Craig F. Simon

MCT/sel

Enc.

cc: Andrew J. Zarutskie, Town Clerk
May Lou Venuto, Receiver of Taxes (via e-mail)
Jacqueline Calarco, Town Accountant (via e-mail)
James Osborne, Town Engineer (via e-mail)

At a meeting of the Town Board of the Town of Newburgh, held at the Town Hall, 1496 Route 300, in the Town of Newburgh, Orange County, New York on the ___th day of August, 2013 at 7:00 o'clock p.m.

PRESENT:

- Wayne C. Booth, Supervisor
- George Woolsey, Councilman
- Gilbert J. Piauquadio, Councilman
- Elizabeth J. Greene, Councilwoman
- Ernest C. Bello, Jr., Councilman

RESOLUTION OF TOWN BOARD INTRODUCING LOCAL LAW TO OVERRIDE THE TAX LEVY LIMIT ESTABLISHED IN GENERAL MUNICIPAL LAW ARTICLE 3-C AND PROVIDING FOR PUBLIC NOTICE AND PUBLIC HEARING

Councilman/woman _____ presented the following resolution which was seconded by Councilman/woman _____.

BE IT RESOLVED that a Local Law to Override the Tax Levy Limit Established in General Municipal Law Article 3-C be and hereby is introduced before the Town Board of the Town of Newburgh in the County of Orange and State of New York, and

BE IT FURTHER RESOLVED that a copy of the aforesaid proposed local law in final form be laid upon the desk of each member of the Town Board at least seven (7) days prior to a public hearing on said proposed local law, and

BE IT FURTHER RESOLVED that the Town Board shall hold a public hearing in the matter of the adoption of the aforesaid local law to be held at the Town Hall at 1496 Route 300 in the Town of Newburgh, New York on the ___th day of September, 2013 at 7:00 o'clock, p.m., and

BE IT FURTHER RESOLVED that the Town Clerk give notice of such public hearing by the publication of a notice in the official newspapers of the Town, specifying the time when and the place where such public hearing will be held at least three (3) days prior to the public hearing, and posting of such notice together with a copy of such local law in accordance with the requirements of the Municipal Home Rule Law and Chapter 25 of the Code of the Town of Newburgh.

The question of the adoption of the foregoing resolution was duly put to a vote on roll call which resulted as follows:

George Woolsey, Councilman voting _____

Gilbert J. Piaquadio, Councilman voting _____

Elizabeth J. Greene, Councilwoman voting _____

Ernest C. Bello, Jr., Councilman voting _____

Wayne C. Booth, Supervisor voting _____

The resolution was thereupon declared duly adopted.

INTRODUCTORY LOCAL LAW NO. __ OF THE YEAR 2013

**A LOCAL LAW TO OVERRIDE THE TAX LEVY LIMIT ESTABLISHED IN
GENERAL MUNICIPAL LAW 3-C**

BE IT ENACTED by the Town Board of the Town of Newburgh, as follows:

Section 1. Legislative Intent

It is the intent of this local law to override the limit on the amount of real property taxes that may be levied by the Town of Newburgh, County of Orange pursuant to General Municipal Law § 3-c, and to allow the Town of Newburgh, County of Orange to adopt a town budget for (a) town purposes and (b) any other special or improvement district governed by the town board for the fiscal year 2014 that requires a real property tax levy in excess of the "tax levy limit" as defined by General Municipal Law § 3-c.

Section 2. Authority

This local law is adopted pursuant to subdivision 5 of General Municipal Law § 3-c, which expressly authorizes the town board to override the tax levy limit by the adoption of a local law approved by vote of sixty percent (60%) of the town board.

Section 3. Tax Levy Limit Override

The Town Board of the Town of Newburgh, County of Orange is hereby authorized to adopt a budget(s) for the fiscal year 2014 that requires a real property tax levy in excess of the limit specified in General Municipal Law, §3-c.

Section 4. Severability.

If any clause, sentence, paragraph, subdivision, or part of this Local Law or the application thereof to any person, firm or corporation, or circumstance, shall be adjusted by any court of competent jurisdiction to be invalid or unconstitutional, such order or judgment shall not affect, impair, or invalidate the remainder thereof, but shall be confined in its operation to the clause, sentence, paragraph, subdivision, or part of this Local Law or in its application to the person, individual, firm or corporation or circumstance, directly involved in the controversy in which such judgment or order shall be rendered.

Section 5. Effective date.

This local law shall take effect immediately.

16. ENGINEERING:

- i. Water Treatment Chemical Bid**
- ii. Stewart Water Storage Tank**

AUG 21 2013

16a

TOWN OF NEWBURGH
TOWN ENGINEER
1496 Rte. 300
Newburgh, NY 12550
(845) 564-7814

MEMORANDUM

TO: Wayne Booth, Town Supervisor & Town Board
FROM: James W. Osborne, Town Engineer *JWO*
DATE: August 13, 2013
RE: **W \ WATER TREATMENT CHEMICAL BIDS**

I am requesting Town Board action on the following items:

1. Rescind the prior approval for Item 2B – Sodium Hypochlorite to CLFP awarded to Slack Chemical Co. at a unit price of \$ 0.944 / gal.
2. Award Item 2B – Sodium Hypochlorite to CLFP to JCI Jones Chemicals at a unit price of \$ 0.90 / gal.

If you have any questions or comments, I am available to discuss them with you.

JWO/id

cc: A. Zarutskie, Town Clerk
J. Platt, DPW Comm.
J. Guido, CAMO
J. Calarco, Accountant

**TOWN OF NEWBURGH
TOWN CLERK'S OFFICE**
1496 Route 300
Newburgh, New York 12550
(845) 564-4554

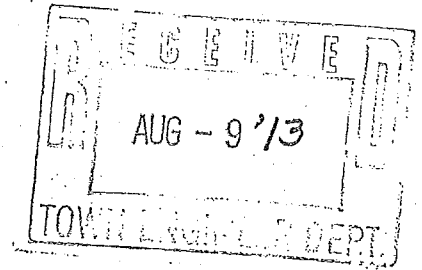

MEMORANDUM

TO: James Osborne, Town Engineer

FROM: Deborah A. Smith, Deputy Town Clerk

DATE: August 9, 2013

Re: 2013 Chemical Bid

The bid for the 2013 Chemical Bid was awarded at the August 5, 2013 Town Board Meeting.

There was an error made on the spread sheet submitted to Jeff Egitto, CAMO, showing the results of the bid.

The bid submitted by JCI Jones Chemicals, located in Warwick, New York should have read \$.90 instead of no bid for Item 2B Sodium Hypochlorite.

AUG 21 2013

KB

TOWN OF NEWBURGH
TOWN ENGINEER
1496 Rte. 300
Newburgh, NY 12550
(845) 564-7814

MEMORANDUM

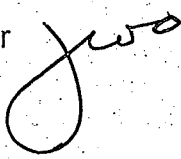
TO: Wayne Booth, Town Supervisor & Town Board
FROM: James W. Osborne, Town Engineer 
DATE: August 14, 2013
RE: W \ STEWART AIRPORT WATER STORAGE TANK

Based on the cost estimates presented to the Town Board in the Draft Engineer's Report for the above project, the total project cost is \pm \$ 2M if all the project elements are included. The Town Board has established a capital project for this work and has to date allocated \$858,500 towards the completion of the project.

Based on discussions with Jackie Calarco, Town Accountant, it is recommended that the Town Board add to the funding of the capital project by transferring \$400,000 from the Capital Reserve Fund to this Capital Project. The Town Board's preliminary approval is required so that Mark Taylor, Attorney for the Town can prepare the necessary resolutions for Town Board action.

As the above requires authorization from the Town Board, I am requesting that this item be placed on the next available agenda for approval. If you have any questions or comments, I am available to discuss them with you.

JWO/id

cc: M. Taylor, Attorney
J. Calarco, Accountant
J. Platt, DPW Comm.

17.ACCOUNTING: Software Upgrade Purchase (Computer Reserve)

AUG 21 2013

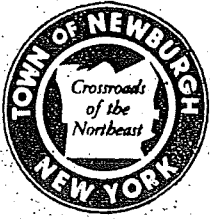

TOWN OF NEWBURGH

1496 Route 300, Newburgh New York 12550

JACQUELINE M. CALARCO, CPA
ACCOUNTANT

845-564-5220
Fax 845-566-1432
E-Mail: townacct@frontiernet.net

To: Wayne C. Booth, Supervisor
CC: Board Members
From: Jackie Calarco, Town Accountant
Date: August 13, 2013
RE: AcuPrint Upgrade

We use a program called "Acuprint" to securely print all of our checks. Our version of AcuPrint is currently outdated and is no longer supported by the manufacturer. The cost of the upgrade is \$2,495 plus an annual maintenance charge of \$785. A copy of the proposal is attached.

Please approve the purchase of the upgrade out of Computer Reserves. The current balance in Computer Reserve is \$41,918.73.

INVESTMENT PROPOSAL
FOR
TOWN OF NEWBURGH, NY

Product Reference	Product Description	Units	Unit Price	Extended Cost	Annual Maint
	AcuPrint				
	Upgrade Version 'Pro' to 'Pro 7'	1.0	\$2,495	\$2,495	\$785
Total				\$2,495	\$785

Payment Terms

License Fees are due upon signing of contract. Services are billed based on a percentage of milestones as follows:

100% Due Upon Delivery \$2,495.00

Terms - NET/30 - Invoices are due and payable within thirty (30) days from the invoice date.

Invoices not paid within forty-five (45) days of the invoice date will have a 1.5 percent per month interest charge assessed against the unpaid balance from the due date of invoice until the date of payment.

Above Proposal accepted in Full –

Vendor: KVS Information Systems, Inc.

Client: Town of Newburgh, NY

By:

By:

Name (Print):

Name (Print):

Title:

Title:

Date:

Date:

Please mail to 821 Maple Road, Williamsville, NY 14221 or fax to 716-626-1973.

ADDITIONAL NOTES/INFORMATION

Pricing

Pricing for KVS software and services is effective for 60 days from the date of the quotation. Third party product pricing is effective for 30 days from the date of the quotation.

Shipping

Third party product pricing does not include shipping and handling charges. This will be billed at actual cost.

AcuPrint

AcuPrint Forms Processing requires the use of a PCL5 compliant printer. Color printers are not support by AcuPrint. The municipality will also be required to purchase a MICR toner cartridge for the printer.

18. PLANNING BOARD: Landscape Bond Estimate

AUG 21 2013

8

KALA

Karen Arent Landscape Architect

Memorandum

To: Mr. Wayne Booth, Town Supervisor and Town Board

From: Karen Arent, Landscape Architectural Consultant to the Town of Newburgh Planning Board

Date: August 16, 2013

Re: Landscape Bond Estimate for Valon & Vaton Steakhouse
34 Plank Road
Town Project Number 2012-26

Consultant: Talcott Engineering

Cc: Chairman John Ewasutyn and the Town of Newburgh Planning Board, Michael Donnelly, Esq., Mr. Bryant Cocks, Mark Taylor, Esq., Ms. Cindy Martinez, Mr. Gerald Canfield, Mr. Charlie Brown with Talcott Engineering

Attached for the Town Board's review is a landscape cost estimate for the above referenced project. The cost estimate, for the amount of \$14,100, is reasonable.

The landscape inspection fee for this project is \$2,000

The above requires Town Board action and should be placed on your next available agenda.

Talcott Engineering DESIGN, PLLC.

1 GARDNERTOWN ROAD * NEWBURGH, NY 12550
(845)-569-8400 * (fax) (845)-569-4583

Landscape Bond Estimate
Valon & Vaton Steakhouse
34 Plank Road, Town of Newburgh
Orange County, New York
Planning Board Application #2012-26
Job#: 12126-ADM
Date: June 26, 2013

Wichita Blue Juniper (5 gal.) - 4 @ \$330.00 ea =	\$1,320.00
Red Maple (2-2 1/2" cal.) - 5 @ \$330.00 ea. =	1,650.00
Winter Gem Boxwood (5 gal.) - 9 @ \$100.00 ea. =	990.00
Inkberry Holly (3 gal.) - 6 @ \$75.00 ea. =	450.00
Flowering Dogwood (6'-7') - 6 @ \$330.00 ea. =	1,980.00
Compact Burning Bush (30"-36") - 3 @ \$75.00 ea. =	225.00
Chinese Juniper (5 gal.) - 15 @ \$100.00 ea. =	1,500.00
Japanese Garden Juniper (2 gal.) - 3 @ \$75.00 ea. =	225.00
Prairie Fire Crabapple (2-2 1/2" cal.) - 2 @ \$330.00 =	660.00
Bird's Nest Spruce (3 gal.) - 8 @ \$75.00 =	600.00
"Hameln" Dwarf Fountain Grass (2 gal.) - 11 @ \$50.00 =	550.00
Sandy Cherry (2-2 1/2" cal.) - 3 @ \$330.00 =	990.00
Steeple Arborvitae (3-3 1/2" cal.) - 3 @ \$330.00 =	990.00
White Pines (4'-5') - 6 @ \$330.00 =	1,980.00

Bond Amount: \$14,110.00

Inspection Fee: \$2,000.00

Note: Talcott Engineering Design has no control over market conditions, contractor bidding methods or costs of labor, materials or equipment. Therefore, we do not guarantee that contractor proposals or actual landscape costs will not vary from the cost estimate shown hereon.

19. DATA PROCESSING

AUG 21 2013

August 21st Audit Meeting

19

Data Processing

Discussion of GIS system

Purchase of Five (5) Dell Optiplex 7010 Computers @ \$ 900.00 from the Computer Reserve account # 001-878

1 for Fleet Maintenance to replace a 2005 computer

**1 for Clerks Office Hunting & Fishing
(mandated by NYS DEC)**

1 for the Supervisor at his desktop to replace a 2006 computer

1 for Cindy to replace a 2006 computer

1 for Marsha to replace 2002 computer

Purchase of (47) forty seven virtual e-mails from g-mail at a cost of \$ 60.00 each per year for a total cost of \$ 2820.00 from the computer reserve account # 001-878

Purchase of one HPLJ 4100 Laser Jet printer from Priority One Technical Services Inc. for Animal Control for \$ 515.00 from the computer reserve account # 001-878 this will give the ability to print BAS data off site.

The above purchases of \$ 7835.00 to be from the Computer Reserve account # 001-878 which currently has a balance of \$ 36,334.00

Purchase of Two (2) computers for Highway from Dell

1 Lap top to replace a 2006 computer at a cost of \$ 1400.00

**1 Dell Optiplex 7010 computer @ 900.00 for a new location to be used
For GIS system**

**These two computer purchases of \$ 2300.00 to be funded from
Highway Account # 5130.200**



Item Description	Unit Price	Quantity	Total Price
------------------	------------	----------	-------------

Estimated Delivery Date : 06/06/2013

[Learn More](#)

OptiPlex 7010 Desktop Base	\$844.91	4	\$3,379.64
-----------------------------------	-----------------	----------	-------------------

OptiPlex 7010 Desktop Base			[225-2782]
OptiPlex 7010 Desktop Base			
OptiPlex 7010 Desktop Base 3rd Gen Intel Core i3-3220 Processor (Dual Core, 3.30GHz, 3MB, w/ HD2500 Graphics), Dell OptiPlex 7010	3rd Gen Intel Core i3-3220 Processor (Dual Core, 3.30GHz, 3MB, w/ HD2500 Graphics), Dell OptiPlex 7010		[225-2782] [319-0466]
4GB, NON-ECC, 1600MHZ DDR3,1DIMM,OPTI	4GB, NON-ECC, 1600MHZ DDR3,1DIMM,OPTI		[319-0218]
Dell USB KB, English, WIN7/8, Optiplex and Precision Desktop	Dell USB KB, English, WIN7/8, Optiplex and Precision Desktop		[331-9586]
No Monitor Selected, Dell OptiPlex	No Monitor Selected, Dell OptiPlex		[320-3704]
Intel Integrated Graphics w/DP/DVI, OPTI	Intel Integrated Graphics w/DP/DVI, OPTI		[320-3778]
500GB 2.5 3.0Gb/s SATA with 16MB DataBurst Cache,OptiPlex DT/SFF	500GB 2.5 3.0Gb/s SATA with 16MB DataBurst Cache,OptiPlex DT/SFF		[320-3016]
1394 Controller Card,Low Profile,Dell OptiPlex Desktop	1394 Controller Card,Low Profile,Dell OptiPlex Desktop		[341-5471]
Windows 7 Professional,,Media, 32-bit, Optiplex, English	Windows 7 Professional,,Media, 32-bit, Optiplex, English?? Windows 7 Label, OptiPlex, Fixed Precision, Vostro Desktop?? Dell Client System Update (Updates latest Dell Recommended BIOS, Drivers, Firmware and Apps),OptiPlex??Software, DDPA (Dell Data Protection Access), version 2.3, OptiPlex x010		[421-5580] [330-6228] [421-5334] [421-8276]
Dell MS111 USB Optical Mouse,OptiPlex and Fixed Precision	Dell MS111 USB Optical Mouse,OptiPlex and Fixed Precision		[330-9458]
Intel Standard Manageability, Dell OptiPlex 7010	Intel Standard Manageability, Dell OptiPlex 7010		[331-6245]
16X DVD+/-RW SATA, Data Only, OptiPlex 9010	16X DVD+/-RW SATA, Data Only, OptiPlex 9010??Thank you for Choosing Dell		[318-1540] [318-2231]
Heat Sink, Mainstream, Dell OptiPlex 7010 Desktop	Heat Sink, Mainstream, Dell OptiPlex 7010 Desktop		[331-6252]
OptiPlex 7010 Desktop Standard PSU	OptiPlex 7010 Desktop Standard PSU??Regulatory label, Mexico, for OptiPlex 7010 Desktop??Enable Low Power Mode for EUP Compliance,Dell OptiPlex		[318-1892] [331-7358] [330-7422]
Documentation,English and French,Dell OptiPlex	Documentation,English and French,Dell OptiPlex??Power Cord,125V,2M,C13,Dell OptiPlex		[331-2030] [330-1711]
No ESTAR Settings, OptiPlex Resource DVD contains Diagnostics and Drivers for Dell OptiPlex 7010	No ESTAR Settings, OptiPlex Resource DVD contains Diagnostics and Drivers for Dell OptiPlex 7010		[331-8325] [331-6251]
1 W ready mode - exceeds FEMP 3W recommendation. Mode can be disabled in BIOS. OptiPlex	1 W ready mode - exceeds FEMP 3W recommendation. Mode can be disabled in BIOS. OptiPlex		[310-1959]
No Quick Reference Guide,Dell OptiPlex	No Quick Reference Guide,Dell OptiPlex		[310-9444]
Shipping Material for System,Desktop,Dell OptiPlex 990	Shipping Material for System,Desktop,Dell OptiPlex 990		[331-1269]
Microsoft Office Home and Business 2013, OptiPlex, Precision, Latitude	Microsoft Office Home and Business 2013, OptiPlex, Precision, Latitude		[630-AABE]
Basic Hardware Service: Next Business Day Onsite Service After Remote Diagnosis 2	Basic Hardware Service: Next Business Day Onsite Service After Remote Diagnosis 2 Year Extended??Basic Hardware Service: Next Business Day Onsite Service After Remote Diagnosis Initial Year??Dell Limited Hardware Warranty Plus		[995-1923] [995-0903] [995-4303]

Year Extended	Service Extended Year(s)??Dell Limited Hardware Warranty Plus Service Initial Year??Dell ProSupport Service Offering Declined	[995-4093] [991-2878]
Thank you for buying Intel/Dell	Thank you for buying Intel/Dell	[466-9045]

Subtotal:	\$3,379.64
Shipping and Handling:	\$0.00
Sales Tax:	\$0.00
Total Amount:	\$3,379.64

Important Things to Know:

- For answers to your Frequently Asked Questions (FAQs) [click here](#).
- Dell reserves the right to cancel any orders arising from pricing or other errors.
- Your order is subject to Dell's [Terms and Conditions of Sale](#) which include a binding arbitration provision.
- If your order includes a service contract, please visit our [Service Contracts](#) website for details about your contract.
- Learn more about the [Estimated Delivery Date](#)

Thanks again for choosing Dell!

© 2006 Dell Inc. U.S. only. Dell Inc. is located at One Dell Way, Mail Stop 8129, Round Rock, TX 78682.

DELL**QUOTATION**

QUOTE #: 625303627

Customer #: 459815

Contract #: 44ADD

Customer Agreement #: PT65340

Quote Date: 6/29/12

Date: 6/29/12 11:04:11 AM

Customer Name: TOWN OF NEWBURGH

TOTAL QUOTE AMOUNT:	\$1,214.84		
Product Subtotal:	\$1,214.84		
Tax:	\$0.00		
Shipping & Handling:	\$0.00		
Shipping Method:	Ground	Total Number of System Groups:	1

GROUP: 1	QUANTITY: 1	SYSTEM PRICE: \$1,193.85	GROUP TOTAL: \$1,193.85
Base Unit:	Inspiron 17R Notebook (Inspiron 5720) (225-2613)		
Processor:	3rd Gen Intel Core i7-3612QM processor 6MB cache, up to 3.1 GHz (317-9780)		
Memory:	8GB,DDR3,2 DIMM (317-9569)		
Keyboard:	Dell Chiclet Keyboard with Multi-touch Touchpad, English-Int'l (331-6919)		
Monitor:	17.3 Inch High Definition+ (900p) LED Display with TrueLife (320-3017)		
Video Card:	Intel® HD Graphics 4000 (318-1615)		
Video Memory:	Intel® Centrino® Wireless 2230, 2x2 bgn + Bluetooth (421-7208)		
Hard Drive:	1TB 5400 RPM SATA Hard Drive (342-4053)		
Floppy Disk Drive:	Switch by Design Studio - Moon Silver (318-1617)		
Operating System:	Windows 7 Professional 64 bit Service Pack 1, English, No Media (421-5804)		
NIC:	Integrated 10/100/1000 Network Card (430-3605)		
TBU:	Adobe Acrobat Reader (410-0548)		
CD-ROM or DVD-ROM Drive:	8X Tray Load CD/DVD Burner (Dual Layer DVD+/-R Drive) (318-1620)		
Sound Card:	Audio 2.0 supporting WaveMaxx 3.0 (318-1547)		
Processor Cable:	Intel Centrino Wireless 2230, 2x2 bgn + Bluetooth (430-4601)		
Cable:	Power cord, 125V, 3.2 feet, US (331-1894)		
Documentation Diskette:	English/Spanish/French Documentation (331-6280)		
Bundled Software:	Microsoft Office Starter: reduced-functionality Word and Excel with ads. No PowerPoint or Outlook (410-0487)		
Controller Option:	Shipping Material, Direct and Retail (331-6918)		
Factory Installed Software:	McAfee Security Center, 15 Month, CNB (410-0573)		
Software Disk Two:	Resource DVD, Inspiron 5720 (331-6175)		
Software Disk Two:	Additional Software (421-7824)		
Feature	48 WHr 6-cell Lithium Ion Battery (312-1315)		
Feature	No Optical Device Software (410-0677)		
Service:	Dell Hardware Limited Warranty, Extended Year (991-4833)		
Service:	Dell Hardware Limited Warranty, Initial Year (991-4823)		
Service:	Dell Limited Hardware Warranty Plus In-Home Service After Remote Diagnosis, 1 Year Extended (991-4873)		
Service:	Dell Limited Hardware Warranty Plus In-Home Service After Remote Diagnosis, Initial Year (991-		

	4863)
Service:	Soft Contracts Dell In-Home Hardware Agreement (420-8878)
Service:	Warranty Support, 1 Year Extended (900-8221)
Service:	Warranty Support, Initial Year (960-2780)
Support:	Accidental Damage Service, 2 Years (931-7871)
Support:	Soft Contracts Business Accidental Damage Agreement (412-0357)
Misc:	Wireless Display Application and Driver (421-7083)
	Thank You for Choosing Dell (730-1816)
	Trusted ID, IDSafe, 12 Month Subscription, Digital Delivery (421-6585)
	Adobe Elements 9.0 Photoshop and Premiere Bundle (410-0658)

SOFTWARE & ACCESSORIES			
Product	Quantity	Unit Price	Total
Dell Wireless Mouse, Black, WM311, Customer Install (330-6856)	1	\$20.99	\$20.99
Number of S & A Items: 1		S&A Total Amount: \$20.99	

SALES REP:	Wesley Dewald	PHONE:	800-981-3355
Email Address:	wesley_dewald@dell.com	Phone Ext:	7250392

Please review this quote carefully. If complete and accurate, you may place your order online at www.dell.com/qto (use quote number above). POs and payments should be made to *Dell Marketing L.P.*

If you do not have a separate agreement with Dell that applies to your order, please refer to www.dell.com/terms as follows:

If purchasing for your internal use, your order will be subject to *Dell's Terms and Conditions of Sale-Direct* including Dell's U.S. Return Policy, at www.dell.com/returnpolicy#total. If purchasing for resale, your order will be subject to *Dell's Terms and Condition of Sale for Persons or Entities Purchasing to Resell*, and other terms of Dell's PartnerDirect program at www.dell.com/partner. If your order includes services, visit www.dell.com/servicecontracts for service descriptions and terms.

Quote information is valid for U.S. customers and U.S. addresses only, and is subject to change. Sales tax on products shipped is based on "Ship To" address, and for downloads is based on "Bill To" address. Please indicate any tax-exempt status on your PO, and fax your exemption certificate, with seller listed as *Dell Marketing L.P.*, to Dell's Tax Department at 800-433-9023. Please include your Customer Number.

For certain products shipped to end-users in California, a State Environmental Fee will be applied. For Asset Recovery/Recycling Services, visit www.dell.com/assetrecovery.

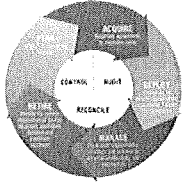

**PRIORITY ONE
TECHNICAL
SERVICES, INC.**

TODD BAUM: OWNER

11 Beech Street

Newburgh, New York 12550-1921

(845)541-9113

PRICE QUOTE

DATE	QUOTE	CUSTOMER
08/16/2013	PRICING INFORMATION	TOWN OF NEWBURGH

ITEM #	DESCRIPTION	PRICE
1	HPLJ 4050n: 17 ppm printer Includes HIGH YIELD TONER CARTRIDGE (C4127X) INSTALLATION AND 1 YEAR PARTS/LABOR WARRANTY	\$495.00
***	Additional Cartridges (C4127X)	\$65.00/each
2	HPLJ 4100n: 25 ppm printer Includes HIGH YIELD TONER CARTRIDGE (C8061X) INSTALLATION AND 1 YEAR PARTS/LABOR WARRANTY	\$515.00
***	Additional Cartridges (C8061X)	\$70.00/each

Please contact Customer Service at priority04@ol.com with any questions or comments.

Thank you for your business!



Municipality GIS 20/20



For The
Town of Newburgh, NY

July 2nd, 2013

Prepared by:
Software Consulting Associates
54 Elizabeth St.
Red Hook, NY

Account Representative: Wil LaBossier
Phone: (845) 758-0104
Fax: (845) 758-0884
E-Mail: wil@sca-corp.com
Website: www.sca-corp.com

GIS – Web Based GIS

Municipality Web Based GIS is a module that enables both internal and external (if desired) users to view parcel information and other GIS data via a web-browser.

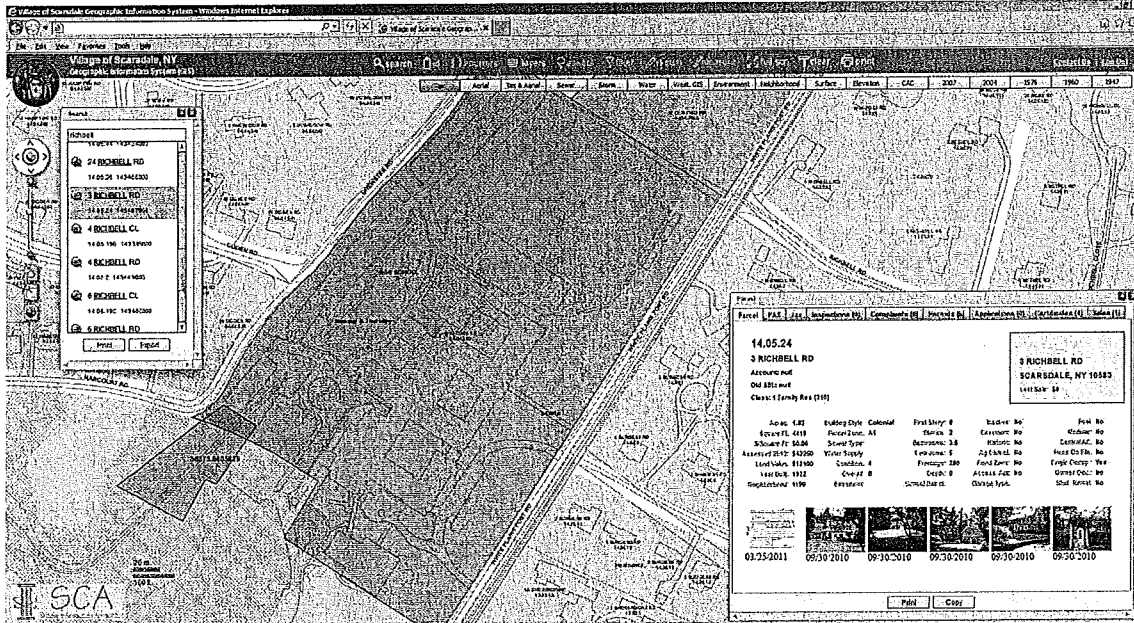

Example of a GIS web application with municipal data

Features of the Municipality GIS:

- Easy, flexible search options.
- Orthographic layer support.
- User level security and access.
- Click to select /unselect single or multiple parcels.
- Abutters Notices (including label print, report and map).
 - Select Multiple Parcels and run Abutters Notices from the combined perimeter of all Parcels.
 - Handle Condominium Complexes as both a single entity and individual units for Abutters Notices and Reporting.
- Click a Parcel to display parcel information, including pictures, documents, property card (if provided by the town) and more.
- Filter parcel select based on vast criteria specific to SCA databases (i.e. acreage, water districts, property class, zoning and more).
- Enabled users can update inspection results from any web-enabled device.
- Create reports.
- Save map in various formats.
- Extract select information to Excel/CSV.
- Color coding and labeling of various search parameter.

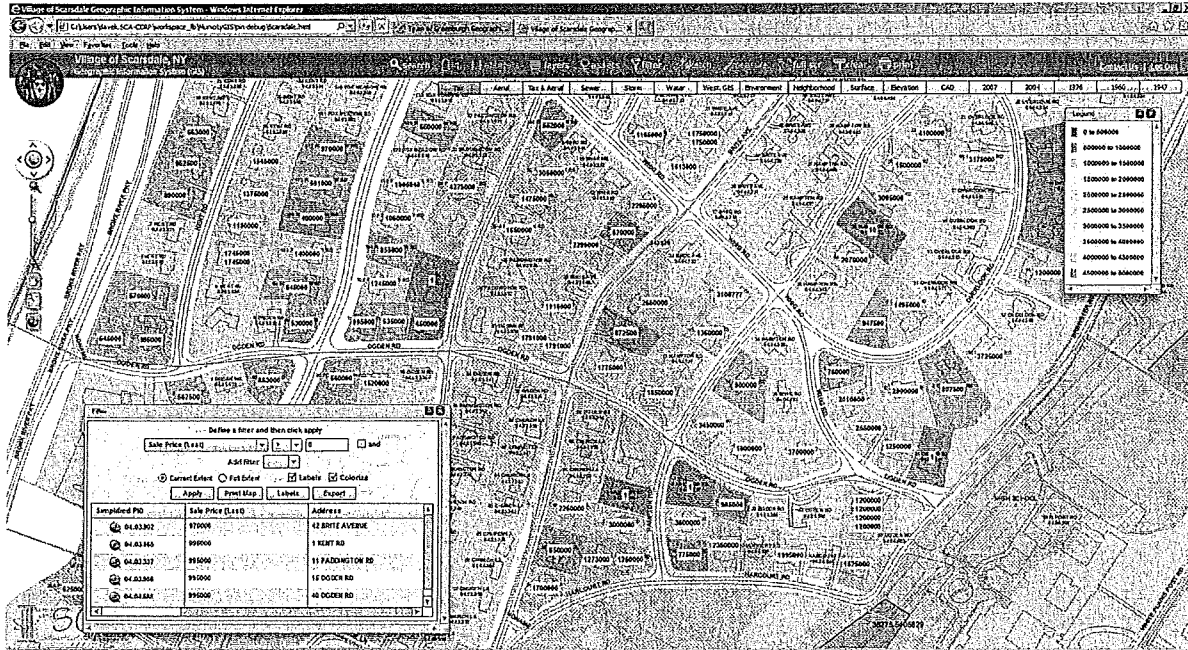

Last Sale Price filter

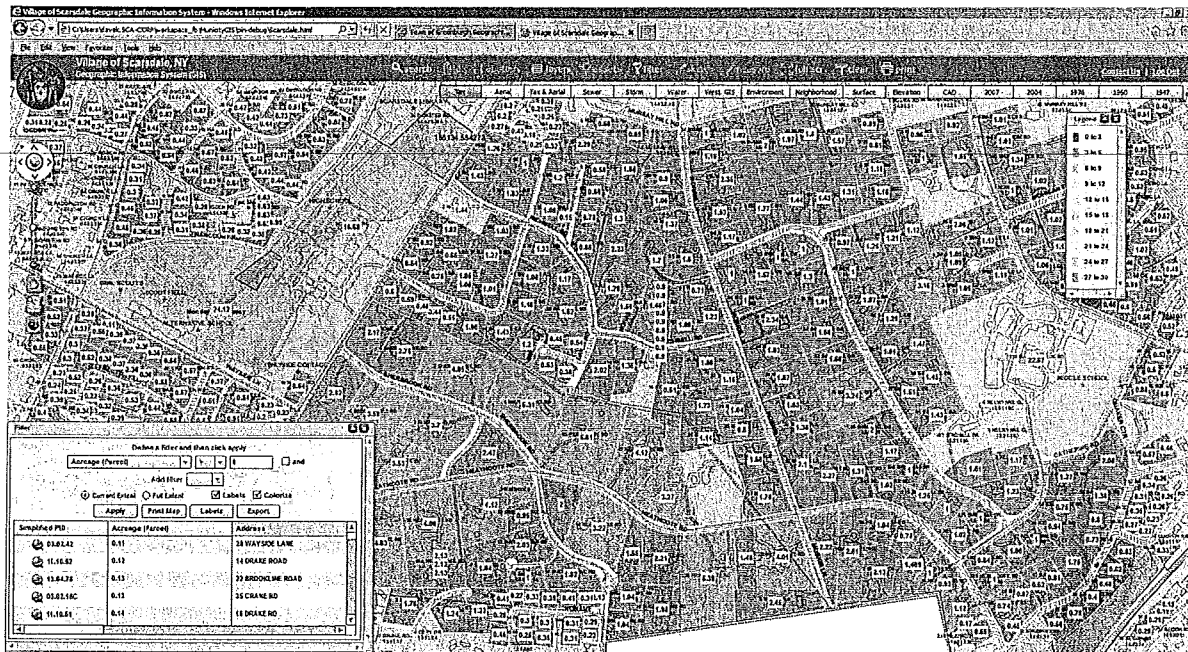

Parcel Acreages for specified map extent

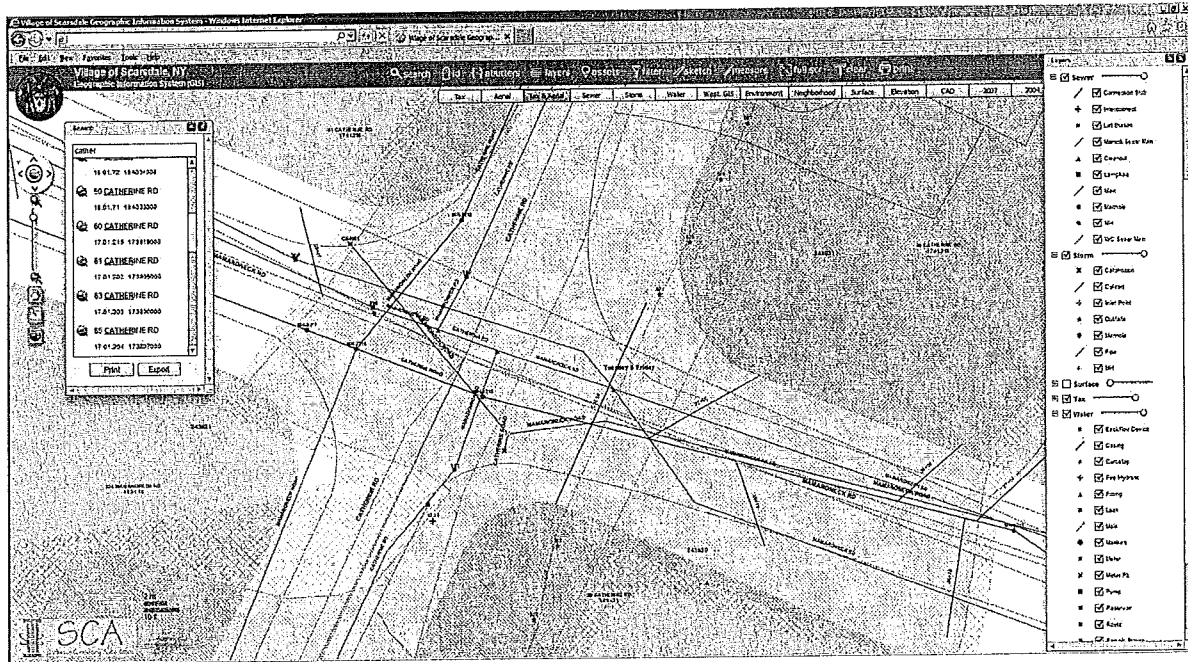

A complex intersection of municipal services in a designated floodplain



Managing assets on an aerial and elevation map

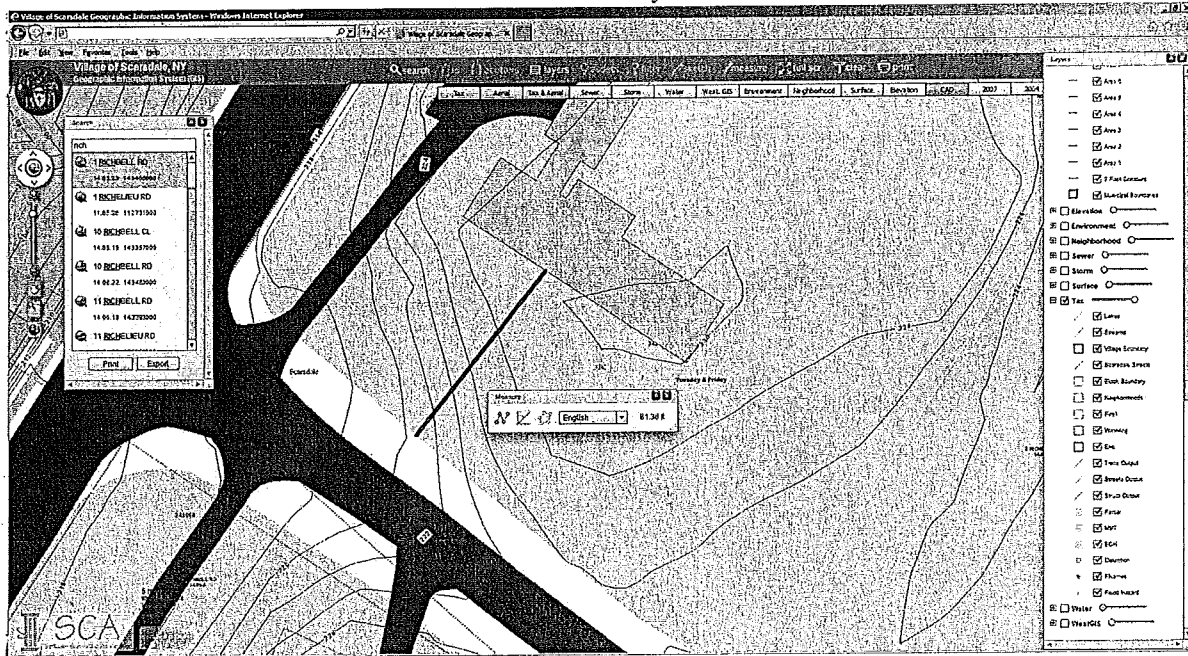

Measuring curbstoep to house

GIS System Architecture:

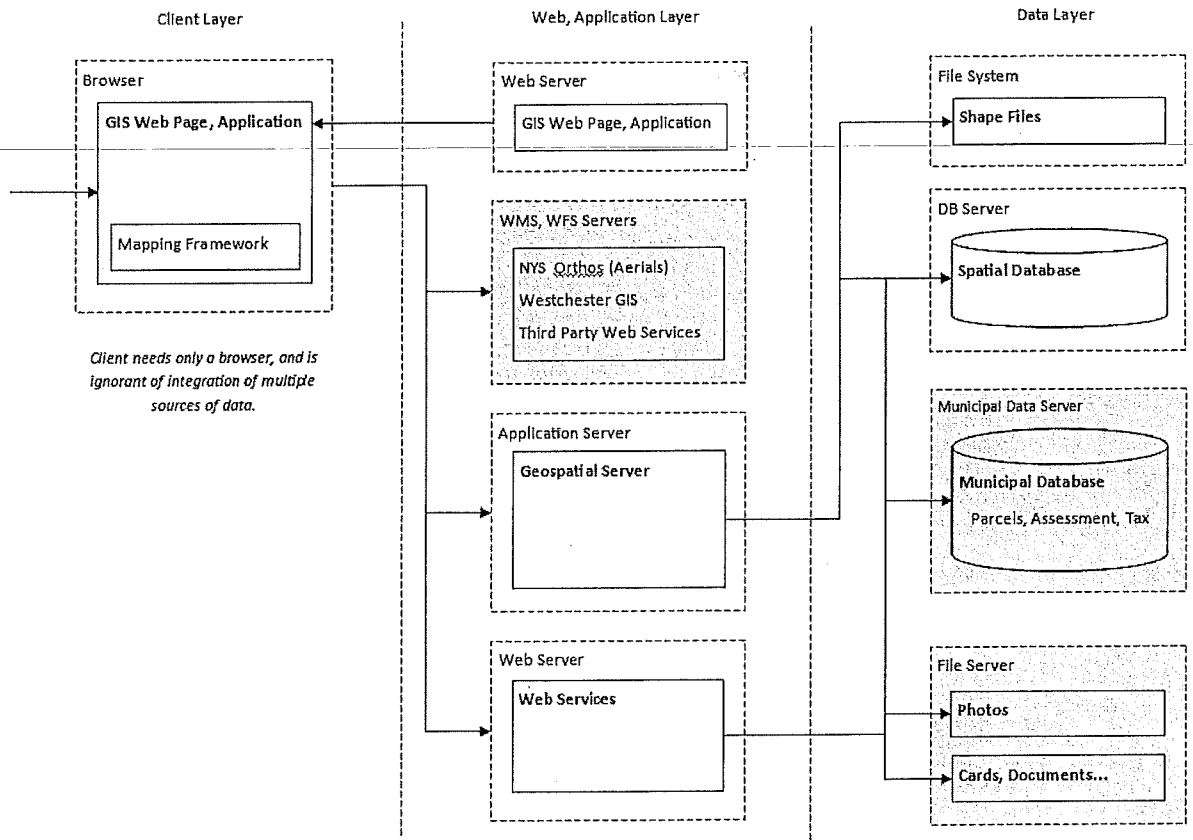



Investment

Municipality GIS 20/20

<input type="checkbox"/> Municipality GIS 20/20	
Software License	\$6,900
Setup, Customization and Training	<u>\$1,000</u>
Total One-Time Cost:	\$7,900
Annual Maintenance and Support	\$900
Annual Hosting Charge (<i>one of the following</i>)	
Internal Use Only (Town Employees Only)	\$1,200
Open to the Public	\$2,400

Authorization

The Town of Newburgh, NY hereby agrees to the procedures outlined above and the "Terms and Conditions" attached hereto and made a part hereof, and authorizes Software Consulting Associates to proceed with the project.

Town of Newburgh, NY

By: _____

Title: _____

Date: _____

SOFTWARE CONSULTING ASSOCIATES

By: _____

Title: _____

Date: _____



Terms and Conditions

This is a legal agreement between you (either an individual or an entity), the end user, and Software Consulting Associates.

Responsibility of Software Consulting Associates (SCA).

SCA shall be responsible for the performance of the services provided for in this agreement in accordance with the "Performance Schedule." SCA shall be responsible for the correctness and accuracy of its work, based upon the material and information supplied by you. Regardless of your acceptance of completed materials when delivered, SCA shall correct errors found either by you or SCA. See "Warranties; Limitations" for SCA's liability for all services.

Your Responsibility.

You shall be responsible for the correctness and accuracy of the information you supply to SCA, for providing SCA with timely decisions and answers to questions raised by SCA, for inclusion of sufficient funds in your budget to pay SCA for services, and for the prompt payment of invoices. You shall also be responsible for completing your work in accordance with the "Performance Schedule."

Adjustments to Performance Schedule; Unauthorized Delays.

- A. Adjustments to Schedule. Upon the mutual consent of you and SCA, the "Performance Schedule" may be changed or extended as provided under "Changes" below.
- B. Unauthorized Delays. In the event of any unauthorized delay on your part, SCA may impose delay charges upon providing notice thereof to you. An "unauthorized delay" shall mean any delay not authorized by both SCA and you.

Variations from Standard Methods or Procedures.

Variations from SCA's standard methods and procedures must be requested by you, in writing, specifying the exact nature of the desired variations. SCA will accommodate such variations wherever possible, with any additional charges for such variations, as determined by SCA and approved by you, to be paid by you.

Payment Terms.

All payments shall be made within 30 days of receipt of the invoice/voucher. You shall not discount nor withhold any portion of the amount for any reason. Late payments will be charged interest at the rate of 1.5% for each month or part thereof that such payment is in arrears.

Software.

The Software being delivered pursuant to this agreement is being licensed to you pursuant to a License Agreement (the "License"), attached hereto and made apart hereof, between the publisher of the software and you. You agree that all terms, conditions and limitations set forth in the License shall apply to this contract as it relates to the Software.

Computer Hardware.

Any computer hardware being delivered in accordance with this agreement is being delivered with the manufacturer's warranty. The manufacturer's warranty is in lieu of all other warranties, express or implied, and SCA shall have no obligation or liability under "Warranties; Limitations" or otherwise with respect to hardware.

Title.

All computer software and other intellectual property of SCA used in performing its services shall remain the property of SCA.

Term and Termination.

- A. The initial term of this agreement, unless sooner terminated as hereafter provided, shall be for one year, commencing on the date hereof.
- B. Either party shall have the right to terminate this agreement with immediate effect if the other party fails to cure to such party's reasonable satisfaction any material breach or violation of this agreement within 60 days after such party has given the other written notice thereof.
- C. Upon termination, all work prepared by SCA may, at your option, become your property, and SCA shall be entitled to receive just and equitable compensation for all services performed.



Warranties; Limitations.

- A. SCA warrants that the services provided hereunder will be performed by qualified personnel in a good and workmanlike manner and that any deliverables will be free of material defects. SCA's liability and your exclusive remedy for failure of any service or deliverable to meet this warranty shall be limited to reperformance, at SCA's cost, of such service or deliverable. SCA's warranty does not extend to failures arising out of (i) incorrect or insufficient data, specifications or instructions provided by you or (ii) work or services performed by others.
- B. The foregoing warranties are in lieu of all other warranties, whether oral, written, express, implied or statutory. Implied warranties of fitness and merchantability shall not apply. SCA's warranty obligations and your remedies thereunder are solely and exclusively as stated herein.
- C. The limitations and protections against liability afforded SCA herein shall apply to any action or claim in connection with the services, whether based on contract, tort, statute or otherwise (including negligence, warranty and strict liability). The cumulative liability of SCA for all obligations, warranties and guaranties, whether express or implied, with respect to services performed hereunder, shall be limited to the amount paid to SCA pursuant to this contract. SCA shall not be liable to you or any other person or entity for indirect, special, incidental, punitive or consequential damages arising from the performance or nonperformance of services, irrespective of whether the claims or actions for such damages are based upon contract, tort, negligence, strict liability, warranty or otherwise.
- D. No action may be maintained or proceeding commenced by you or others against SCA with respect to services unless such action or proceeding is commenced within one year after completion by SCA of the particular services to which such action or proceeding relates. Either party shall be entitled to recover reasonable attorney fees incurred in the successful enforcement of this agreement, regardless of whether a cause of action is commenced.

Changes.

You may at any time request changes in the scope of this agreement. Moreover, SCA may suggest changes. Where changes are agreed to by the parties, SCA shall issue a Change Order for your review and signature describing the changes as well as the adjustments in schedule and fees occasioned by the changes in scope. SCA shall not be required to implement any change until you have signed and returned the Change Order.

Notices.

All notices and other communications which are required or permitted to be given, shall be in writing and shall be delivered either personally, by facsimile, by reputable overnight courier or by registered or certified mail and shall be deemed effectively received (i) if delivered in person, on the date of such delivery, (ii) if transmitted by facsimile, on the date indicated on the sender's receipt of confirmation, (iii) if delivered by overnight courier, on the next business day following deposit thereof with such overnight courier, or (iv) if sent by mail, upon the third business day following the deposit thereof, postage prepaid.

Force Majeure.

If any performance by any party shall be prevented, hindered or delayed by reason of any cause beyond the reasonable control of such party (such event being hereafter called an "event"), including, without limitation, acts of God, riots, fires, floods, unusually severe weather, curtailment or termination of sources or supplies of energy or power, inability to obtain or delay in obtaining materials or supplies, strikes or other disputes involving such party or its subcontractors or suppliers, acts of war, insurrection, civil unrest, riot or disorder, acts of governmental authorities, changes in law or regulation, or any other cause beyond the reasonable control of such party, whether similar or dissimilar to those expressed hereinabove, such party shall be excused from performance to the extent that its performance is so prevented, hindered or delayed. Such excuse from performance shall extend so long as the event continues to prevent, hinder or delay the performance by such party. The party whose performance is affected shall give the other parties notice within 15 days of the event specifying the event, the performance affected and the anticipated date, if any, performance can be made.

Disclaimer of Association.

This agreement shall not be construed as creating a partnership, joint venture, agency or any other association which would impose upon one party liability for the acts or omission of the other, and neither party shall have the right to bind the other.

No Waiver.

Any failure by either party hereto to enforce at any time any term or condition shall not be considered a waiver of that party's right thereafter to enforce each and every term and condition.



Software Consulting Associates, Inc.

Dispute Resolution.

The parties mutually agree to seek mediation as the preferred alternative of dispute resolution in the event of any disagreement over the terms of this agreement.

SOFTWARE CONSULTING ASSOCIATES.

54 Elizabeth St.

Red Hook, NY 12571

845/758-0104

19.

NEW YORK STATE DEPARTMENT OF ENVIRONMENTAL CONSERVATION
Division of Fish, Wildlife & Marine Resources
License & Promotional Sales
625 Broadway, 1st Floor, Albany, New York 12233-4790
Phone: (518) 402-8843 • **Fax:** (518) 473-2105
Website: www.dec.ny.gov

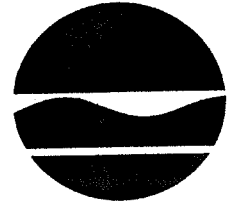

Joe Martens
Commissioner

April 9, 2013

Dear License-Issuing Agent:

This letter is your formal notification that the Department of Environmental Conservation (DEC) will be transitioning to a new Automated Licensing System (DECALS) vendor, Accela, Inc., by January 1, 2014. We will do our best to keep you informed of actual conversion dates, as well as any and all information necessary to make this transition as seamless as possible for license-issuing agents (Agents) and sporting license buyers. Accela will be providing agent training on the new system later this year, and DEC will provide detailed information on training dates and locations as soon as they become available.

In preparation for the transition to a new vendor, we are asking our Agents to complete the attached Agent Equipment Inventory Form and return it to DEC in the enclosed postage-paid envelope, no later than April 26. This will ensure that we have a complete and accurate list of our Agents' current equipment and future needs well in advance of the conversion.

Based on a recent survey of Agents, we are reassessing which equipment is absolutely necessary for the successful sale of sporting licenses, and what is the most cost effective and efficient means of supporting and maintaining this equipment. The survey indicated that the majority of Agents do not use the DEC-provided scanners. As a result of this, we are planning to discontinue use of these devices. We have also learned that due to limited counter space and the inconvenience of maintaining multiple printers, many agents are no longer using the DEC-provided receipt printers. With this in mind, we will also be transitioning away from the use of receipt printers. In order to still meet Agents' account reporting needs, we are designing a new Daily Sales Report that can be either printed on a standard plain paper office printer or saved as an electronic copy. This will eliminate the need for the separate receipt printer. In addition to the standard daily sales report, you will be able to run reports of all licenses sold under your point of sale (POS) number by date range. This is something that you have been asking for and will be provided to you with the new system. We will continue use of Verifone valeron printers for license and tag issuance.

Additionally, in preparation for transition, we are notifying all Agents that they will be required to supply their own computer for selling sporting licenses with the new Accela system, as well as continuing to use their own internet providers. While this has been our preferred policy over the past 4 years, and most agents are already using their own PCs, there still some agents using DEC-owned PC/Monitors/keyboards. Please be advised that upon implementation of the new sales system at the end of the year, the DEC-owned computers will become obsolete and the current Verizon DECALS URL will no longer be in service.

To assist you with your computer needs, below is a list of acceptable operating systems and browsers for accessing the new licensing system:

Supported Operating Systems:

Windows XP SP3 (32 bit or 64 bit)
Windows Vista SP2 (32 bit or 64 bit)
Windows 7 (32 bit or 64 bit)
Windows Server 2003
(32 bit (x86)) - minimum
Windows Server 2008 (R2 64 bit (x64))
Microsoft Windows Mobile 7
Apple iOS

Supported Internet Browsers:

Mozilla Firefox 17
Internet Explorer 8 or 9
Safari 5
Google Chrome 23

* Agents will also need to install
Silverlight Run-Time Edition 4.0
(All above are free to download)

We realize that some of these changes may impact your interest and/or ability to continue to sell licenses. Should you wish to opt out of selling, please provide a letter to the above address, including your company name and Agent ID number with your request to opt out. Town Clerks must provide a Town Resolution addressed to the License Sales Supervisor at the above address.

Once we have a complete inventory of equipment, we will provide you with disposition instructions for any devices in your possession that you will no longer need.

Thank you for your continued support as we begin the transition process to Accela and the new DECALS software. We look forward to continuing our working relationship with you.

Sincerely,

Douglas L. Stang
Assistant Director
Division of Fish, Wildlife and Marine Resources

Attachments

EQUIPMENT INVENTORY FORM

Agent Number: _____ Address: _____

Agent of Record: _____

Phone Number: _____

E-mail: _____

INSTRUCTIONS: Complete the table below with information found on your current DECALS equipment. Do not include model/serial numbers from your personal devices, only the equipment provided by the DEC for license issuance. Model Numbers and Serial Numbers can generally be found on the bottom of your device. If you do not have one of the devices listed below, place 'N/A' in the corresponding boxes. Additional equipment may be added in the space provided at the bottom of the form. Should you have any questions on how to complete this form, please call our hotline number 1-866-472-4332 (Monday-Friday, 8AM-4PM) for assistance.

Equipment Description	Model Number	Serial Number	Is this equipment currently in use? (Y/N)
DEC-owned Computer			
DEC-owned Monitor			
DEC-owned Keyboard			
Scanner			
Verifone Valeron License Printer			
Ithaca Receipt Printer			
Other:			

COMMENTS:

Please complete this form and return it in the enclosed postage-paid envelope by 4/19/2013.

Thank you in advance for your assistance with this effort!

20. POSSIBILITY OF EXECUTIVE SESSION: Litigation (Melon Trucking)

21. ADJOURNMENT