

NOTES:

- EXISTING HOME LOCATIONS ARE APPROXIMATE AND BASED UPON AVAILABLE SATELLITE IMAGES AND THE ALTA/NSPS LAND TITLE SURVEY DOCUMENT PREPARED BY BLOCK & CLARK AND FIELD WORK COMPLETED BY D.W. HANNIG, L.S. #047411 ON 5/18/17.
- A PROPOSED LOT MUST BE VACANT OF ALL EXISTING STRUCTURES BEFORE A BUILDING PERMIT FOR THE INSTALLATION OF A NEW MOBILE HOME WILL BE ISSUED.
- OUT-BUILDINGS ARE NOT TO BE IN THE FRONT YARD OF A MOBILE HOME OR CLOSER TO AN ADJACENT ROAD THAN THE MOBILE HOME.
- OUT-BUILDINGS ARE TO BE PLACED A MINIMUM OF 5 FOOT FROM THE SIDE AND REAR LOT LINES, A MINIMUM OF 6 FOOT FROM THE MOBILE HOME UNIT.
- DECKS THAT ARE ENCLOSED WILL BE CONSIDERED PART OF THE STRUCTURE AND NEED TO COMPLY WITH ALL SETBACKS FOR THE LOT.
- CONTRACTOR SHALL VERIFY WITH LOCAL UTILITY COMPANY THE POSSIBILITY OF ANY UNDERGROUND UTILITIES PRIOR TO ANY EXCAVATION.
- ALL DIMENSIONS MUST BE VERIFIED IN THE FIELD BY THE CONTRACTOR BEFORE START OF CONSTRUCTION. ANY DISCREPANCIES ON THE PLANS OR SPECIFICATIONS, MUST BE REPORTED TO THE ENGINEER PRIOR TO THE START OF CONSTRUCTION.
- THERE IS TO BE A 30' MINIMUM SEPARATION BETWEEN ALL STRUCTURES.

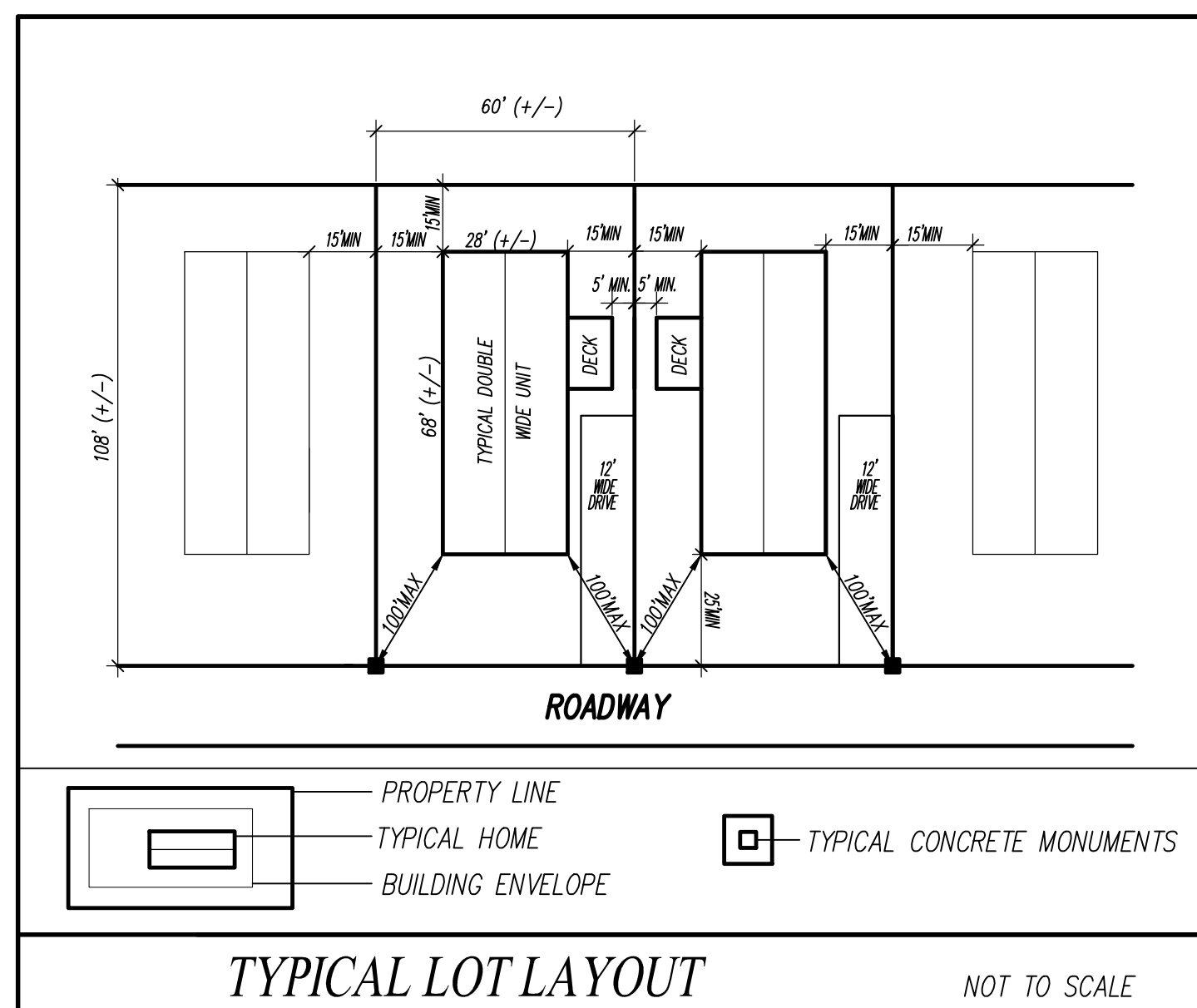
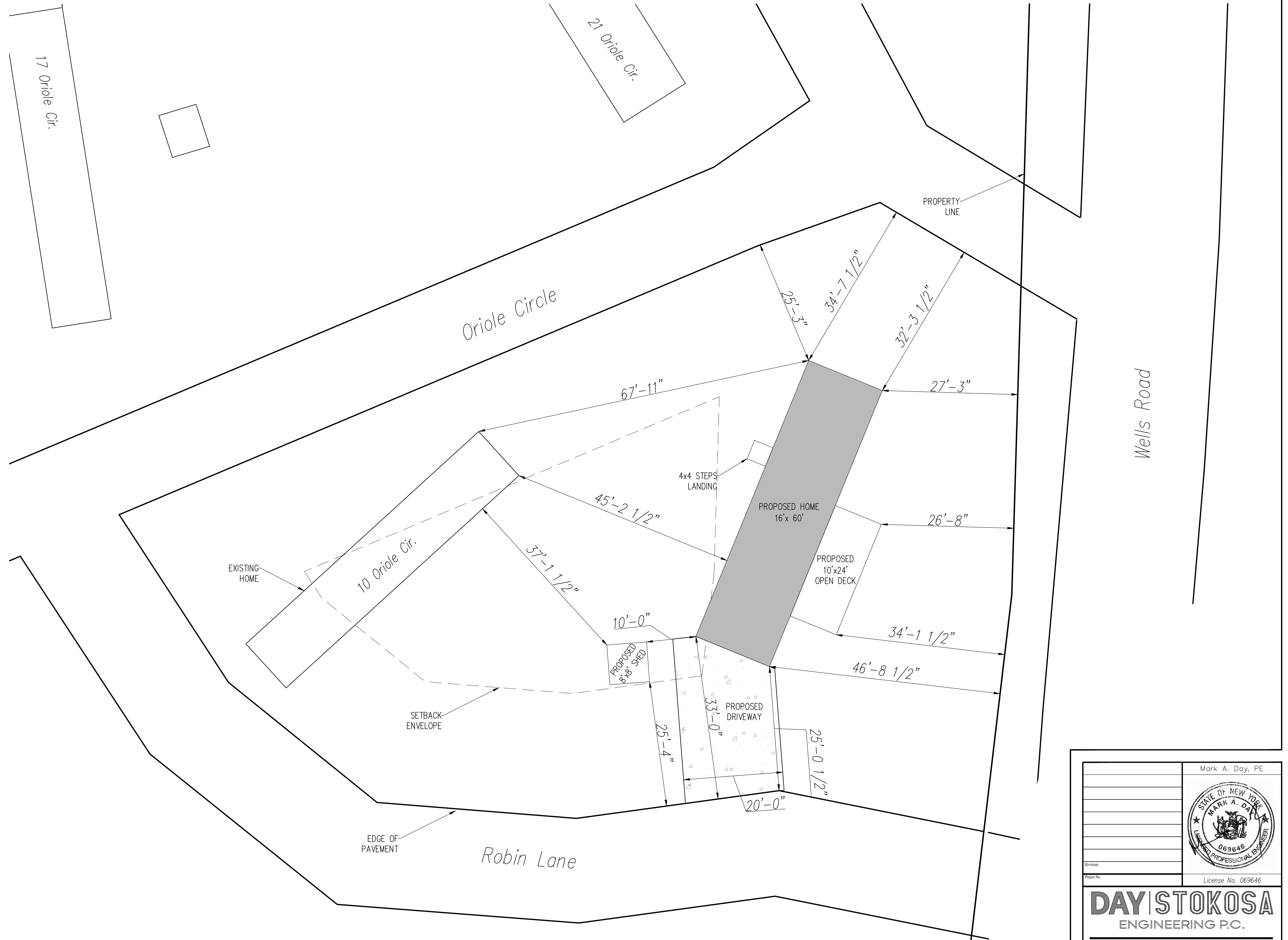

OWNERS

BOTTINI PROPERTIES, LLC

18 CLINTON STREET
WAPPINGERS FALLS NEW YORK 12590

OWNER'S CONSENT

THE UNDERSIGNED APPLICANT OF THIS PROPOSAL HEREON STATES THAT HE IS FAMILIAR WITH THIS MAP, ITS CONTENTS AND ITS LEGENDS AND HEREBY CONSENTS TO ALL SAID TERMS AND CONDITIONS AS STATED HEREON.

BOTTINI PROPERTIES

Mark A. Day, PE	
DAY STOKOSA ENGINEERING P.C.	
3 Van Wyck Lane Suite 2 Wappingers Falls, New York (845)-223-3202	
Lot # 57 Plot Plan	
SCALE 1"=10'	DRAWN BY BJW
DATE 08/09/22	CHECKED BY MAD
1 of 1	

Double Wide Blocking Layout

Maximum Home Width	Maximum Side Overhang	Pier Location	Roof Live Load (PSF)	Maximum Pier Capacity (POUNDS)				
				Maximum Pier Spacing (FEET)				
				4	6	8	10	12
24' Wide 144" Floor	12"	MAIN BEAMS	20 PSF	2570	3655	4740	5825	6910
			30 PSF	2843	4065	5287	6508	7730
28' Wide 168" Floor	12"	MAIN BEAMS	20 PSF	2840	4060	5280	6500	7720
			30 PSF	3147	4520	5893	7267	8640
32' Wide 186" Floor	12"	MAIN BEAMS	20 PSF	3083	4424	5766	7108	8449
			30 PSF	3450	4975	6500	8025	9550

Table A - I-Beam Pier Loads and Footing Sizes:

Pier Spacing	Load	Pier Size	Footing Sizes (In. x In.) Allowable Soil Bearing			
			1500 Psf	2000 Psf	2500 Psf	3000 Psf
Ft.	Lbs.	In. x In.				
4	2240	8 x 16 16 x 16	13 x 21 16 x 16	11 x 19 16 x 16	9 x 17 16 x 16	8 x 16 16 x 16
6	3360	8 x 16 16 x 16	16 x 24 19 x 19	13 x 21 17 x 17	12 x 20 16 x 16	10 x 18 16 x 16
8	4475	8 x 16 16 x 16	18 x 26 22 x 22	16 x 24 19 x 19	14 x 22 17 x 17	12 x 20 16 x 16
10	5600	8 x 16 16 x 16	21 x 29 24 x 24	18 x 26 21 x 21	15 x 23 19 x 19	14 x 22 17 x 17

- NOTES:
- APPLIES TO HOMES THAT DO NOT REQUIRE PERIMETER BLOCKING ALONG THE SIDE WALLS.
 - THE MINIMUM FOOTING DEPTHS FOR PRECAST FOOTINGS ARE AS FOLLOWS (MIN. CONCRETE STRENGTH (f_c) OF 2500 PSI): 4" IF PRECAST. ADD THE MAXIMUM OF 4" OR 50% OF THE DEPTH, IF FOOTINGS ARE POURED IN PLACE.
 - ALL FOOTING SIZES ARE BASED UPON THE PIER LOAD LISTED PLUS A PIER WEIGHT OF 400 LBS. (MIN.)
 - BASED ON A BOX WIDTH OF 120" AND A 6" EAVE.
 - ALL FOOTINGS MUST REST ON UNDISTURBED SOIL AT OR BELOW THE FROST LINE.
 - CONSULT THE LOCAL JURISDICTION FOR THE ALLOWABLE SOIL BEARING.
 - FLOOR SYSTEM MAY CONSIST OF 2x6 #2 FLOOR JOISTS AT UP TO 16" INTERVALS.

Table B - Piers at Mating Wall and Interior Column Locations:

Column Span	Load	Pier Size	Footing Sizes (In. x In.) Allowable Soil Bearing			
			1500 Psf	2000 Psf	2500 Psf	3000 Psf
Ft.	Lbs.	In. x In.				
4	1000	16 x 16	16 x 16	16 x 16	16 x 16	16 x 16
6	1500	16 x 16	16 x 16	16 x 16	16 x 16	16 x 16
8	2000	16 x 16	16 x 16	16 x 16	16 x 16	16 x 16
10	2500	16 x 16	17 x 17	16 x 16	16 x 16	16 x 16
12	3000	16 x 16	19 x 19	16 x 16	16 x 16	16 x 16
14	3500	16 x 16	20 x 20	17 x 17	16 x 16	16 x 16
16	4000	16 x 16	21 x 21	18 x 18	16 x 16	16 x 16
18	4500	16 x 16	22 x 22	19 x 19	17 x 17	16 x 16
20	5000	16 x 16	23 x 23	20 x 20	18 x 18	17 x 17
22	5500	16 x 16	24 x 24	21 x 21	19 x 19	17 x 17
24	6000	16 x 16	25 x 25	22 x 22	20 x 20	18 x 18

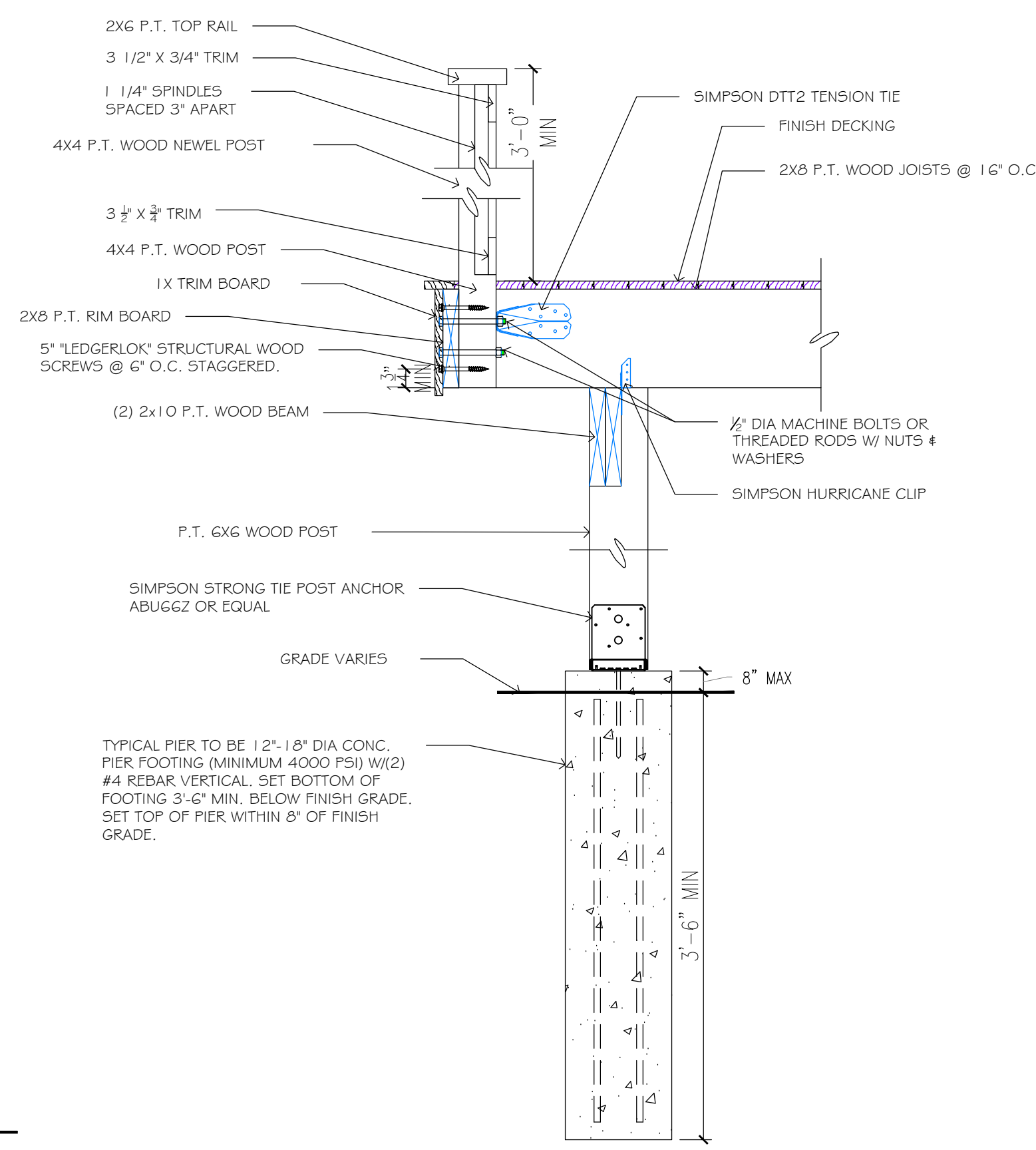

TYPICAL DECK RAIL/POST/FOOTING DETAIL
NOT TO SCALE

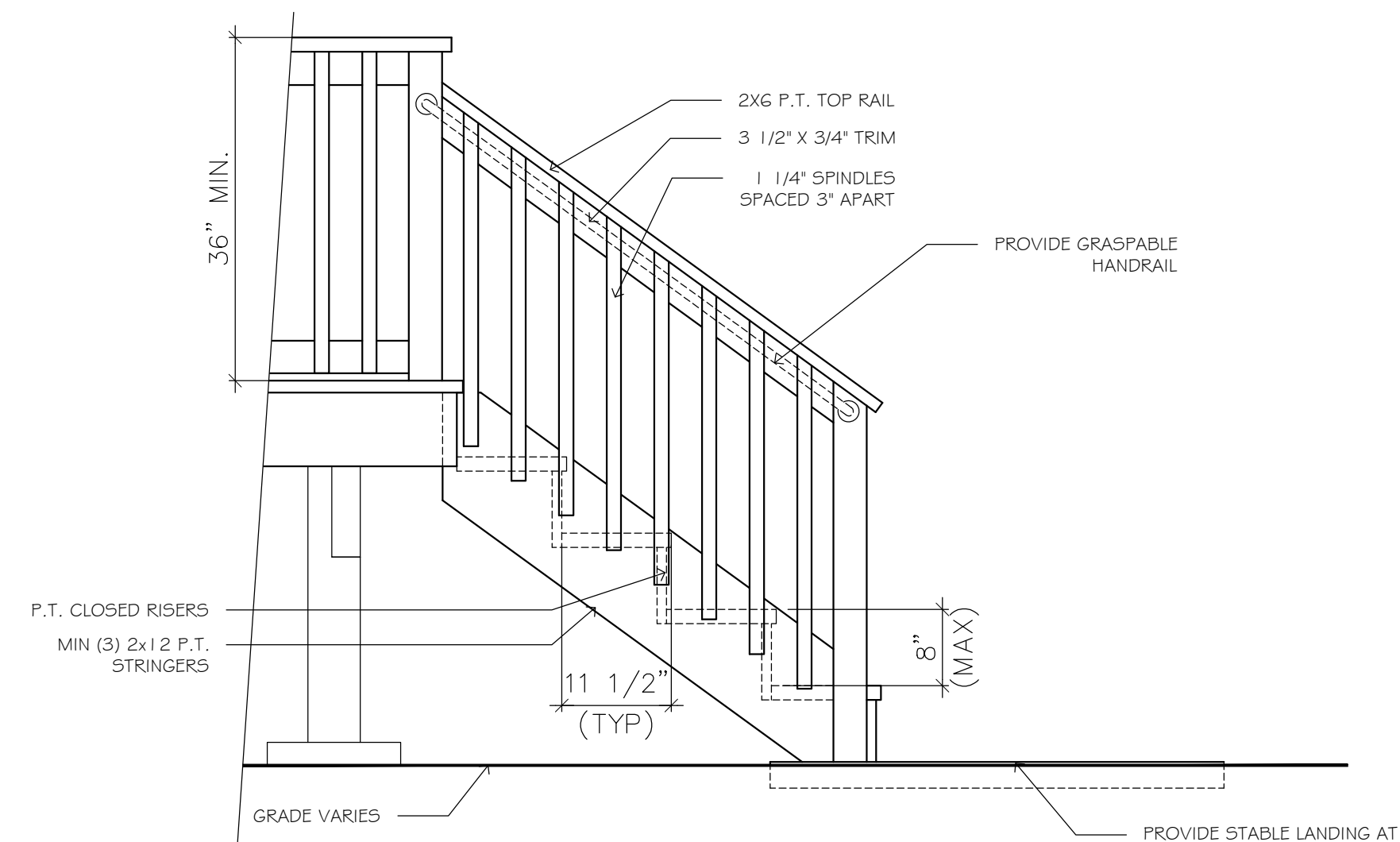

TYPICAL STAIR DETAIL
NOT TO SCALE

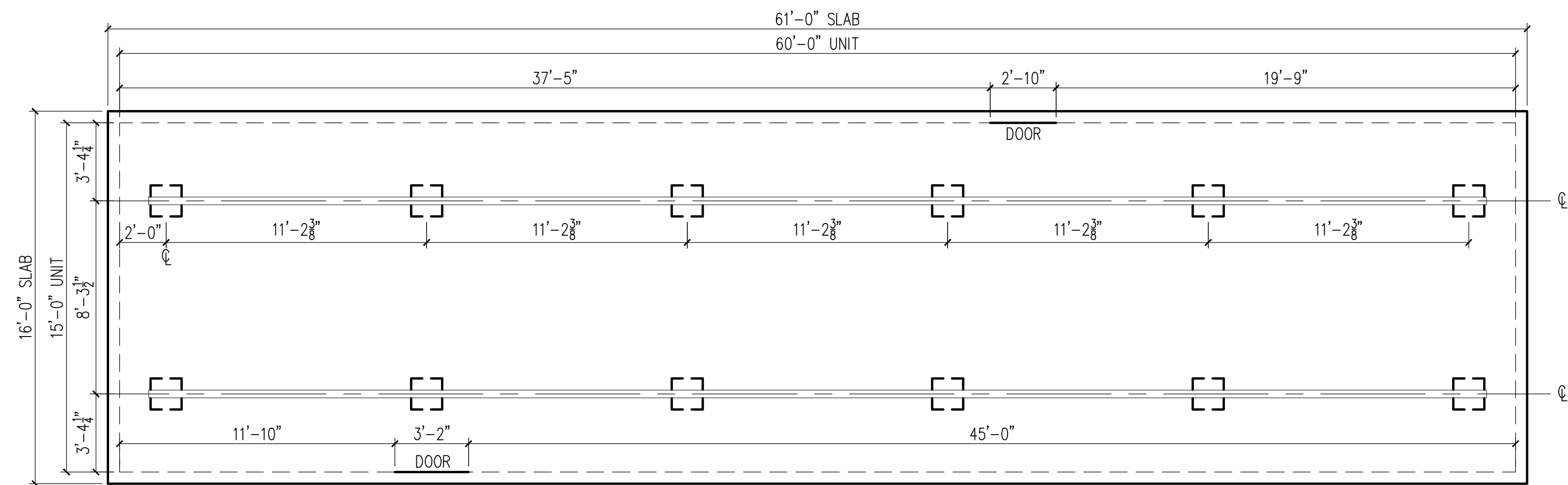

- NOTES:
- CRAWLSPACE MUST BE VENTILATED PER IRC 408.1 AND IRC 408.2 (ONE VENTILATION OPENING TO BE WITHIN 3'-0" OF EACH CORNER OF BUILDING. 1 SQ. FT. NET AREA PER EACH 150 SQ. FT. OF FOUNDATION AREA.) VENTILATION IS NOT REQUIRED WITH CONDITIONED AIR. REFER TO IRC 408.3 FOR REQUIREMENTS.
 - THESE DIMENSIONS DO NOT ALLOW FOR ANY VARIANCE THAT MAY OCCUR IN SITE INSTALLATION SUCH AS GAPPING, OFF CENTER SET OR OTHER FIELD-ENCOUNTERED VARIABLES. ANY ADJUSTMENTS NEEDED IN FOUNDATION WIDTH DUE TO SUCH VARIANCES ARE AT THE DISCRETION OF THE INSTALLER.
 - REFER TO INSTALLATION INSTRUCTIONS FOR ALL OTHER INFORMATION NOT COVERED BY THIS DRAWING. INSTALL PIER AND FOOTINGS AT EACH CORNER OF SIDEWALL WALK-OUT BAY WINDOW UNITS, CONCRETE COMPRESSIVE STRENGTH (FC): 3000 PSI MINIMUM.
 - FOR DEVIATIONS /OR OTHER FOUNDATION DESIGNS CONSULT A LOCAL PROFESSIONAL ENGINEER & YOUR LOCAL BUILDING OFFICIAL.

PIER PLAN
1/4" = 1'

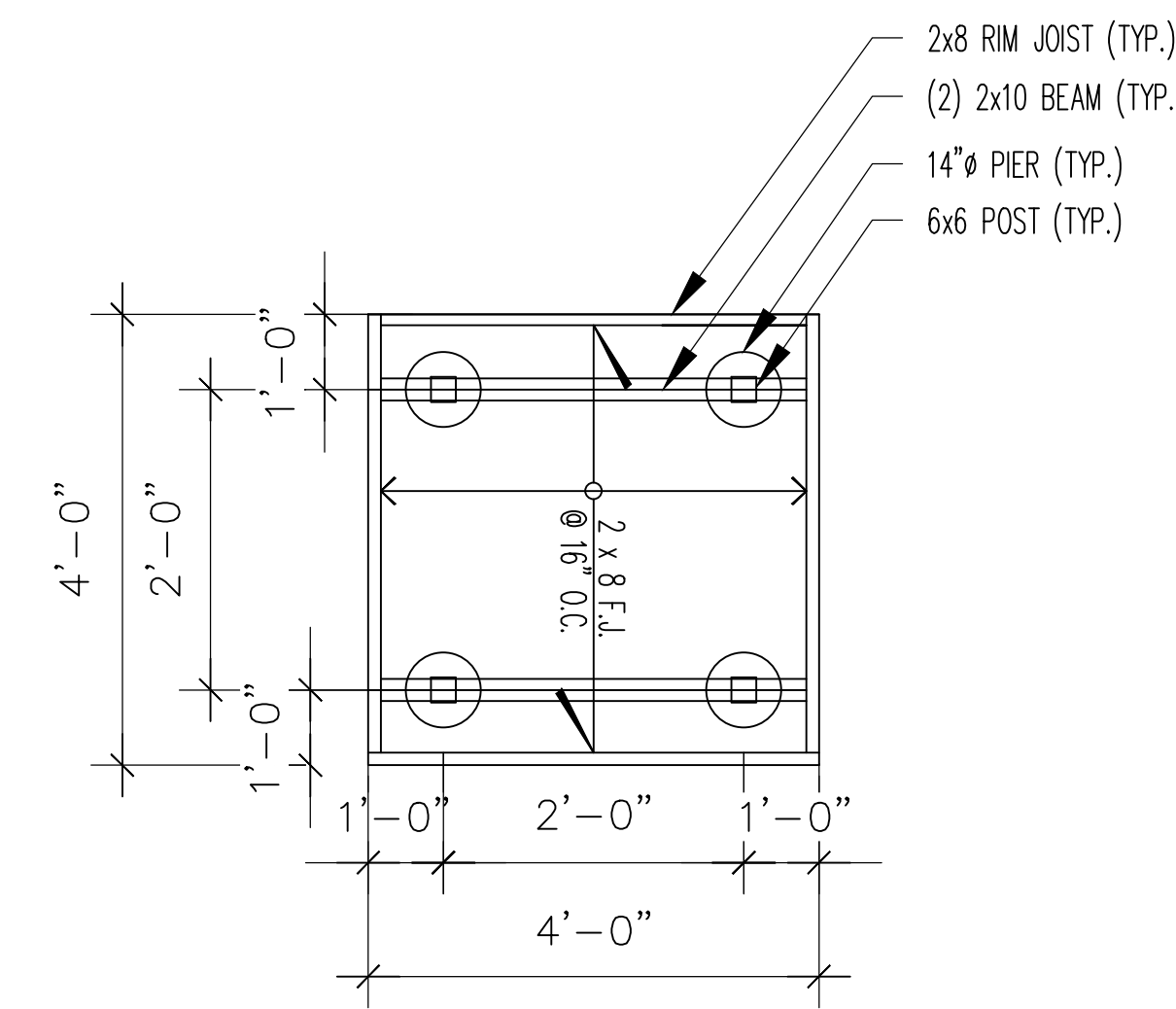

DECK DETAILS - 4' X 4' LANDING
NOT TO SCALE

- RAILING & STAIR NOTES:
- STAIRS WITH (4) OR MORE RISERS SHALL BE PROVIDED WITH HANDRAILS ON AT LEAST ONE SIDE. HANDRAILS SHALL BE A MINIMUM OF 34" IN HEIGHT AND NOT MORE THAN 38" IN HEIGHT. RAILS ARE TO BE MEASURED VERTICALLY FROM THE NOSING OF THE TREADS. CIRCULAR HANDRAILS SHALL HAVE AN OUTSIDE DIAMETER OF AT LEAST 1 1/4" AND NOT GREATER THAN 2". IF THE HANDRAIL IS NOT CIRCULAR IT SHALL HAVE A PERIMETER OF AT LEAST 4" AND NOT MORE THAN 6 1/4".
- PORCHES, DECKS, BALCONIES OR RAISED FLOOR SURFACES LOCATED MORE THAN 30" ABOVE THE FLOOR OR GRADE BELOW SHALL HAVE GUARDS A MINIMUM OF 36" HIGH.
- RISERS ARE TO BE CLOSED SUCH THAT THE OPENING BETWEEN THE TREADS DOES NOT PERMIT THE PASSAGE OF A 4" DIAMETER SPHERE.

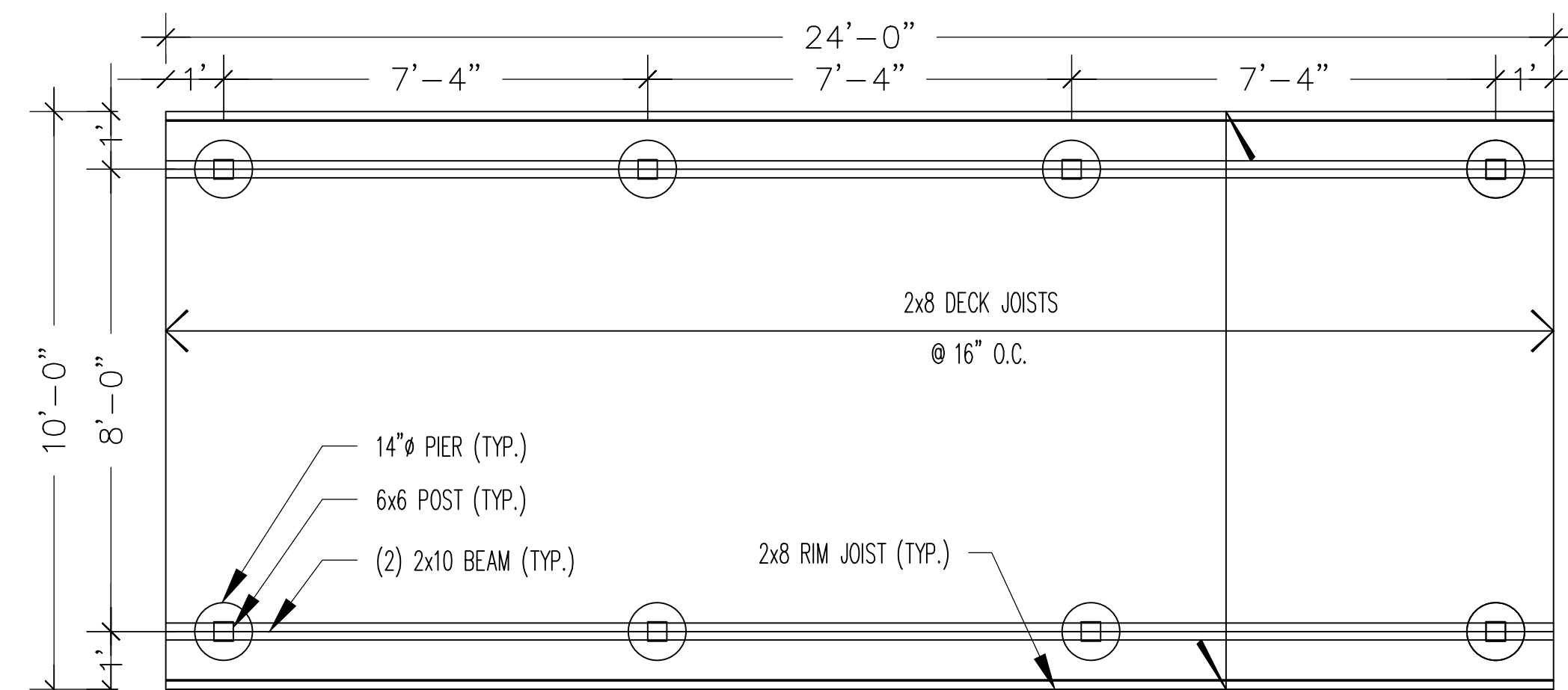

DECK DETAILS - 10' X 24' DECK
NOT TO SCALE

Mark A. Day, PE	
Project No.	2008.182
License No.	069646
DAY STOKOSA ENGINEERING P.C.	
3 Van Wyck Lane Suite 2 Wappingers Falls, New York (845)-223-3202	
Bottini Properties, LLC 5 Robin Lane, BGB West Mobile Home Park Town of Newburgh, Orange County, New York	
Pier Layout & Details	
SCALE	AS NOTED
DATE	08/09/22
DRAWN BY	BJW
CHECKED BY	MAD
1 of 2	

ADDENDUM TO HUD INSTALLATION MANUAL
(ALT. TYPICAL SLAB-ON-GROUND REQUIREMENTS USING INSULATED SKIRTING OPTION)

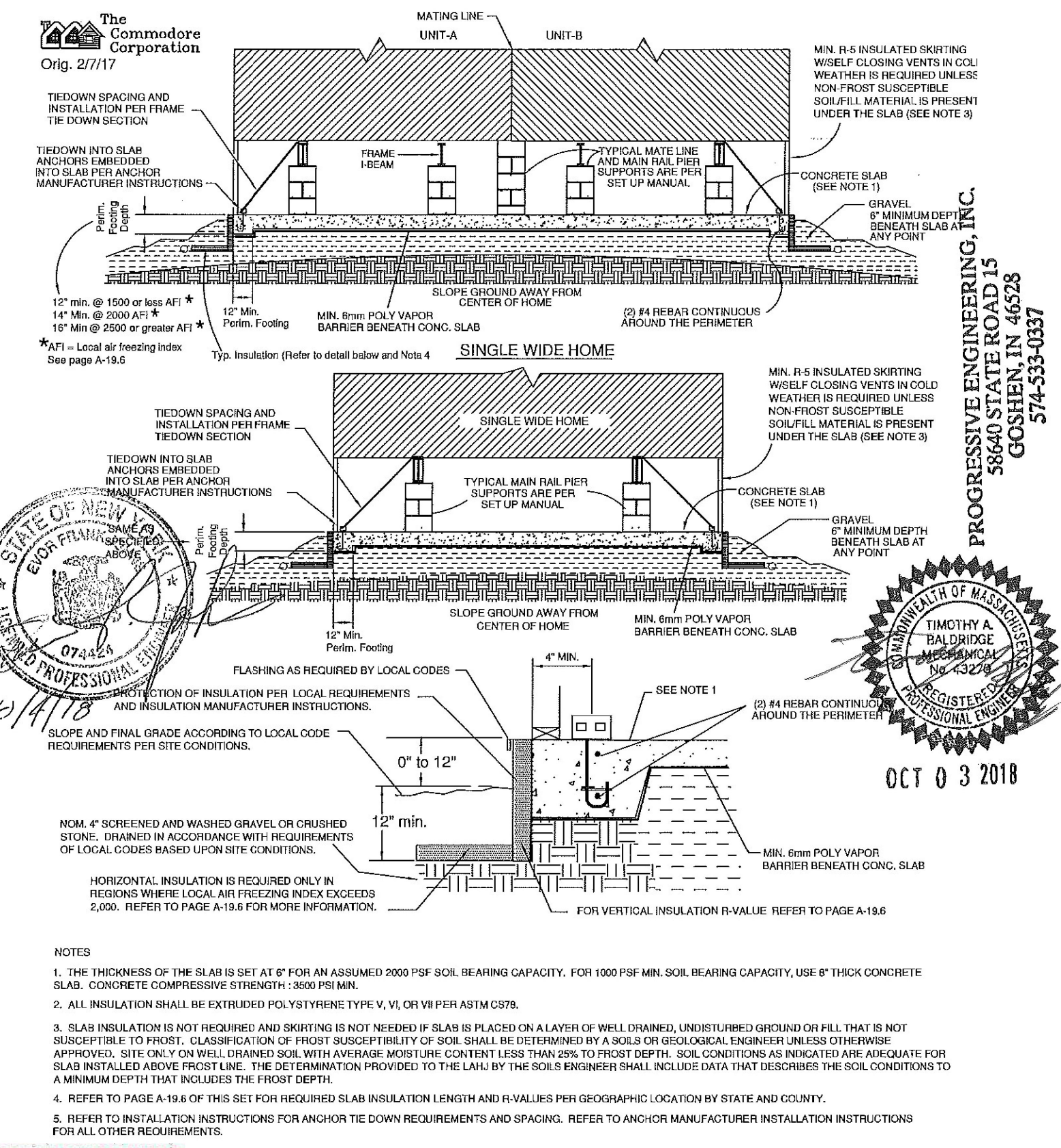

A-19.4
ALT. TYP. SLAB ON GROUND DESIGN - INSULATED SKIRTING
Commodore Homes - 119
Rev. 10/03/18

3/15/2019

ADDENDUM TO HUD INSTALLATION MANUAL
(ALT. TYPICAL SLAB-ON-GROUND REQUIREMENTS USING INSULATED SLAB OPTION)

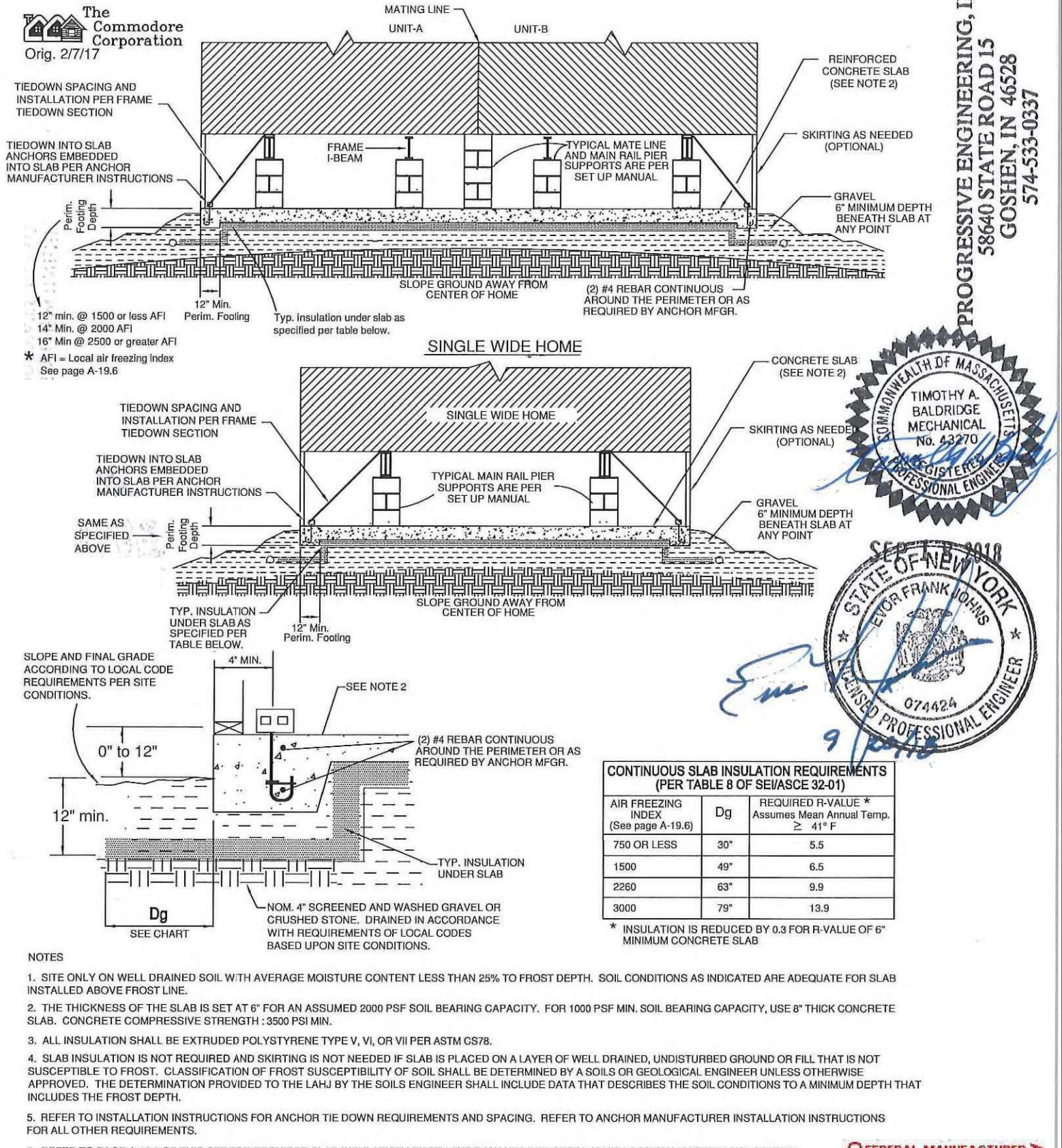

A-19.5
ALT. TYP. SLAB ON GROUND DESIGN - INSULATED SLAB OPTION
Commodore Homes - 120
Rev. 9/7/18

3/15/2019

MIN. FOOTING DEPTH AND INSULATION REQUIREMENTS FOR FROST PROTECTED FOOTINGS IN HEATED BUILDINGS

AIR FREEZING INDEX (° F days)	MIN. FOOTING DEPTH (inches)	VERTICAL INSULATION R-VALUE	HORIZONTAL INSULATION R-VALUE		HORIZONTAL INSULATION DIMENSIONS (INCHES)		
			ALONG WALLS	AT CORNERS	A	B	C
1,600 OR LESS	12	4.8	NOT REQUIRED	NOT REQUIRED	NOT REQUIRED	NOT REQUIRED	NOT REQUIRED
2,000	14	5.6	NOT REQUIRED	NOT REQUIRED	NOT REQUIRED	NOT REQUIRED	NOT REQUIRED
2,500	16	6.7	1.7	4.9	12	24	40
3,000	18	7.8	6.5	8.6	12	24	40
3,500	18	9.0	8.0	11.2	24	30	60
4,000	18	10.1	10.5	13.1	24	36	60

NOTES:
1. REFER TO LOCATION CHART BELOW LISTED BY STATE AND COUNTY TO DETERMINE PROPER AIR FREEZING INDEX PER LOCALITY. FOR STATES NOT LISTED ON CHART BELOW, REFER TO 2015 IRC - TABLE 403.3(2).
2. INFORMATION SHOWN ON THIS PAGE IS PER SECTION R403.3 OF THE 2015 INTERNATIONAL RESIDENTIAL CODE.

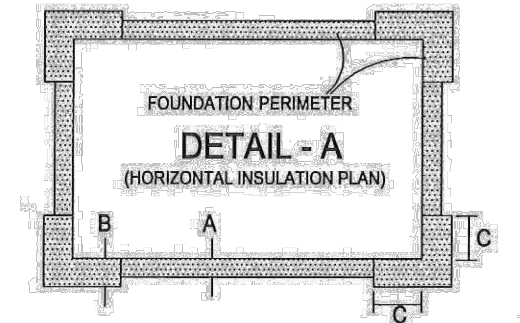

AIR FREEZING INDEX FOR STATES BY COUNTY

STATE	AIR FREEZING INDEX					
	1,600 OR LESS	2,000	2,500	3,000	3,500	4,000
CT	All counties	Hartford, Litchfield				
DE	All counties					
MA	All counties not listed	Berkshire, Franklin, Hampden, Worcester				
MD	All counties					
ME	York	Knox, Lincoln, Sagadahoc	Androscoggin, Cumberland, Hancock, Kennebec, Waldo, Washington	Aroostook, Franklin, Oxford, Penobscot, Piscataquis, Somerset		
NH	All counties not listed					Carroll, Coos, Grafton
NJ	All counties					
NY	Albany, Broome, Chautauq, Cayuga, Cortland, Dutchess, Genesee, Kings, Livingston, Monroe, Otsego, Putnam, Rensselaer, Sullivan, Warren, Yates	All counties not listed	Clinton, Essex, Franklin, Hamilton, Herkimer, Jefferson, Lewis, St. Lawrence, Warren			
PA	All counties not listed	Bucks, Blair, Berks, Chester, Columbia, Dauphin, Carbon, Centre, Clearfield, Clinton, Crawford, Elk, Forest, Huntingdon, Indiana, Jaffrey, Lackawanna, Lycoming, Monroe, Pike, Potter, Schuylkill, Tioga, Venango, Warren, Wayne, Wyoming				
RI	All counties					
VA	All counties					
VT		Barnett, Grand Isle, Rutland, Windham	Addison, Chittenden, Franklin, Orange, Washington, Windsor	Caledonia, Essex, Lamoille, Orleans		
WV	All counties					

A-19.6
AIR FREEZING INDEX INFORMATION FOR SLAB INSULATION R-VALUE & DIMENSIONS
Commodore Homes - 121
Rev. 9/7/18

3/15/2019

Project: Bottini Properties, LLC	
Drawing: HUD Slab Design (By Others)	
Scale:	2 of 2
Date:	Checked By:

Dickover, Donnelly & Donovan, LLP
Attorneys and Counselors at Law

David A. Donovan
Robert J. Dickover

MICHAEL H. DONNELLY, *Retired*

Successor Law Firm To:
Alexander Appelbaum, P.C., Florida, N.Y. (1915-1988)
Ludmerer & Vurno, Esqs., Warwick, N.Y.

28 Bruen Place
P.O. Box 610
Goshen, NY 10924
Phone (845) 294-9447
mail@dddlplaw.com
Fax (845) 294-6553
(Not for Service of Process)

August 31, 2022

VIA FACSIMILIE & FIRST-CLASS MAIL

Kenneth C. Gobetz, Esq.
Wichler & Gobetz, P.C.
400 Rella Blvd, Suite 125
Suffern, NY 10901

RE: BGB West Mobile Park / Town of Newburgh Zoning Board of Appeals

Dear Mr. Gobetz:

As you are aware, I am counsel to the Town of Newburgh Zoning Board of Appeals (“ZBA”).

I am in receipt of your correspondence dated August 24, 2022 and I am also in receipt of the Decision, Order and Judgement issued by the Honorable Robert A. Onofry, J.S.C., dated June 27, 2022.

As you are further aware, at no time was this matter pending before the ZBA and at no time did the ZBA render a decision of any type regarding the issues that have been raised.

Nevertheless, Judge Onofry has directed that “the matter [be] remitted to the ZBA for further proceedings consistent with its decision, and for the imposition of pertinent conditions or requirements.”

In accordance with the Court's directive, this matter will be placed on the ZBA's agenda for Thursday, September 22, 2022. No fee will be assessed, no application will be required nor will any public hearing be convened. The Court has concluded that your client's proposal is not an impermissible expansion of a pre-existing, non-conforming use of the property and, accordingly, the ZBA's evaluation will be limited to the need "for the imposition of pertinent conditions or requirements."

I believe it would be helpful for you to submit copies of the plans that you have for the proposed improvements so that the ZBA may be fully advised of the parameters of your clients' proposal to assist them in their determination as to the necessity, and extent, of the "pertinent conditions or requirements."

Please do not hesitate to contact me should you have any questions with regard to any of the foregoing.

Very truly yours,

A handwritten signature in black ink, appearing to read "D.A. Donovan". The signature is stylized and cursive.

DAVID A. DONOVAN

DAD/lrm

Cc: Siobhan Jablesnik, ZBA Secretary

WICHLER & GOBETZ, P.C.
ATTORNEYS AT LAW

THE OFFICE CENTER AT MONTERELLO
400 RELLA BOULEVARD, SUITE 125
SUFFERN, NEW YORK 10901

KENNETH C. GOBETZ
RANAN J. WICHLER

TEL: (845) 368-1710
FAX: (845) 368-1470

UPS OVERNIGHT

August 24, 2022

David A. Donovan, Esq.
Dickover, Donnelly & Donovan, LLP
28 Bruen Place
Goshen, New York 10924

Re: BGB West Mobile Home Park, LLC: 5 Robin Rd., Newburgh, New York 12550
Replacement of Manufactured Home
SBL: 39-1-42
Application Date 3/17/2021

Dear Mr. Donovan:

We are writing to you at the direction of Michael J. Matsler (see enclosed letter dated August 17, 2022).

We are attempting to obtain a building permit for the above-referenced property after the June 29, 2022, Orange County Supreme Court decision holding that the proposed replacement of the manufactured home did not constitute a new use or an impermissible expansion of the current pre-existing non-conforming use of the applicant's property. To achieve this goal, on August 10, 2022, our client supplemented its building permit application to address the only concerns raised by the building inspection and communicated to the applicant (but not included in the permit denial letter). [A copy of our letter with attachments is enclosed.]

The building permit was denied because the Town asserted that it was an expansion of a non-conforming use. That issue has now been resolved by the Court and there is no issue pending before the Town of Newburgh Zoning Board of Appeals.

We are unsure how to proceed. It is apparent that the building inspector does not intend to act on the supplemental information submitted on August 10, 2022. Mr. Matsler's letter makes clear his position that "the ball is in your court." We're happy to work with you to expedite the issuance of the building permit. Please let us know what else is required.

Yours truly,

WICHLER & GOBETZ, P.C.

cc: Michael J. Matsler, Esq.
Rider, Weiner & Frankel, P.C.
655 Little Britain Road
New Windsor, New York 12553



Rider Weiner & Frankel P.C.
ATTORNEYS & COUNSELORS AT LAW

August 17, 2022

Via Electronic Mail

Kenneth C. Gobetz, Esq.
Wichler & Gobetz, P.C.
400 Rella Boulevard, Suite 125
Suffern, NY 10901

P: 845.562.9100
F: 845.562.9126

655 Little Britain Road
New Windsor, NY 12553

P.O. Box 2280
Newburgh, NY 12550

Re: Town of Newburgh/ZBA v. BGB
Our File No. 802.143

Dear Mr. Gobetz:

I disagree with your statements and interpretation of the Court's decision in your letter dated August 10, 2022 to Mr. Mattina. Judge Onofry stated in his decision and order, pages 23-25 et seq. that "the Court will not direct the ZBA to issue a permit. Rather, the matter is remitted to the ZBA for further proceedings consistent with its decision, and for the imposition of pertinent conditions or requirements...that is, the ZBA is not precluded from reviewing the application." The judge did not order Mr. Mattina or the ZBA to issue a permit.

Your correspondence on this matter should be directed to counsel for the ZBA, David Donovan, Esq. Kindly copy me on your correspondence.

Sincerely,

Michael J. Matsler

ATTORNEYS

David L. Rider
Charles E. Frankel
Michael J. Matsler
Mark C. Taylor
Deborah Weisman-Estis
M. Justin Rider

M. J. Rider
(1906-1968)

Elliott M. Weiner
(1915-1990)

COUNSEL

Stephen P. Duggan, III
John K. McGuirk
(1942-2018)

OF COUNSEL

Craig F. Simon
Irene V. Villacci

:crc

Cc: David Donovan, Esq.
Mark C. Taylor, Esq.
Mr. Gerald Canfield

WICHLER & GOBETZ, P.C.
ATTORNEYS AT LAW

THE OFFICE CENTER AT MONTERELLO
400 RELLA BOULEVARD, SUITE 125
SUFFERN, NEW YORK 10901

KENNETH C. GOBETZ
RANAN J. WICHLER

TEL: (845) 368-1710
FAX: (845) 368-1470

UPS OVERNIGHT

August 10, 2022

Joseph Mattina, Code Compliance Officer
Town of Newburgh, Code Compliance Department
21 Hudson Valley Professional Plaza
Newburgh, New York 12550

Re: BGB West Mobile Home Park, LLC: 5 Robin Rd., Newburgh, New York 12550
Replacement of Manufactured Home
SBL: 39-1-42
Application Date 3/17/2021

Dear Mr. Mattina:

As you are aware, on June 29, 2022, the Orange County Supreme Court decided that the proposed replacement of the manufactured home at 5 Robin Rd., Newburgh, New York 12550 (the "Property") did not constitute a new use or an impermissible expansion of the current pre-existing non-conforming use of the Property. In accordance with the Supreme Court's decision, we are writing to address the other issues raised in your March 18, 2021, letter (enclosed) concerning the building permit application.

In accordance with the Supreme Court's decision, we are supplementing the building permit application to address the concerns raised your March 18, 2021, letter with the following documents:

1. Manufactured Housing Certificate issued to Bottini Properties, LLC as a Certified Retailer of Manufactured Homes;
2. Manufactured Housing Certificate issued to Bottini Properties, LLC as a Certified Installer of Manufactured Homes; and
3. an updated plot plan with additional details demonstrating compliance with current building codes.

Joseph Mattina, Code Compliance Officer
Town of Newburgh, Code Compliance Department
August 10, 2022
Page 2

The applicant no longer intends to construct a shed on the Property so there is no longer any need for an accessory building permit.

All electrical work will be performed by an electrician licensed by Orange County to be hired after issuance of the building permit.

Please contact the undersigned or the Applicant with any further comments or questions.

Yours truly,



WICHLER & GOBETZ, P.C.

Enclosures

cc: Town of Newburgh Zoning Board of Appeals
21 Hudson Valley Professional Plaza
Newburgh, New York 12550

Michael J. Matsler, Esq.
Rider, Weiner & Frankel, P.C.
655 Little Britain Road
New Windsor, New York 12553

SUPREME COURT-STATE OF NEW YORK
IAS PART-ORANGE COUNTY

Present: HON. ROBERT A. ONOFRY, J.S.C.

SUPREME COURT : ORANGE COUNTY

-----X
In the Matter of the Application of
BGB WEST MOBILE HOME PARK, LLC
Petitioner,

To commence the statutory time period for appeals as of right (CPLR 5513[a]), you are advised to serve a copy of this order, with notice of entry, upon all parties.

For a Judgment Pursuant to CPLR Article 78

Index No. EF003506-2021

-against-

DECISION, ORDER AND JUDGMENT

TOWN OF NEWBURGH, TOWN OF NEWBURGH
CODE COMPLIANCE DEPARTMENT, and JOSEPH
MATTINA

Motion Date: May 10, 2022
Motions ## 2 & 3

Respondents.

-----X

The following papers numbered 1 to 29 were read and considered (1) on an amended petition in which Petitioner seeks, *inter alia*, a judgment pursuant to Article 78 of the CPLR annulling a determination of the Respondents denying a building permit, and for an order compelling the Respondents to issue the permit; and (2) a motion by the Respondents to dismiss the amended petition.

Notice of Petition- Petition- Bottini Affirmation- Exhibit I- Memorandum of Law	1-5
Answer- Mattina Affidavit - Exhibits 1-3- Memorandum of Law	6-9
Reply- Zeno Affidavit- Memorandum of Law	10-11
Notice of Amended Petition- Amended Petition- Bottini Affidavit- Zeno Affidavit- Mattina Affidavit- Exhibits A-L- Memorandum of Law	12-18
Notice of Motion- Matsler Affirmation- Mattina Affidavit- Scalzo Affidavit- Jablesnik Affidavit- Exhibits A-K- Memorandum of Law	19-25
Reply and Opposition- Memorandum of Law - Bottini Affidavit- Gobetz Affirmation- Exhibit M	26-29

Upon the foregoing papers, it is hereby,

ORDERED, the petition and motion are decided as set forth herein.

Introduction

The Petitioner commenced this proceeding to challenge the denial of a building permit for its manufactured home park. The Petitioner argues that the Respondents improperly applied current zoning regulations to a pre-existing, non-conforming use of the subject property.

In prior motion practice, the Court directed further clarification, refinement and development of the record.

The Petitioner now seeks judgment on its amended petition.

In opposition, the Respondents move and seek dismissal of the amended petition.

Factual/Procedural Background

The following relevant background facts do not appear to be in dispute.

The Petitioner BGB West Mobile Home Park, LLC owns approximately 8.2 acres of real property located and situate in the Town of Newburgh, Orange County, New York (hereinafter the "Property").

Since 1965, the Property has been continually operated as a 37 unit ("pad") manufactured (mobile) home park. Such use pre-dated/pre-existed the enactment of the current Town code, and constitutes a pre-existing, non-conforming use.

The Petitioner leases home sites ("pads") on the Property to tenants upon which they may place a manufactured home. The tenants own the manufactured homes, and may remove them at the conclusion or termination of the lease term.

The pad at issue in this proceeding is located at 5 Robin Road.

The former tenant had a 12' x 65' manufactured home on the pad, which was non-conforming, but permissible, under the current Town code.

In or about March of 2021, the Petitioner found a new tenant who wanted to place a larger 16' x 60' manufactured home with a 10' x 24' deck on the pad.

The Petitioner filed an application with the Respondents for a building permit for the same. This application is at issue in this proceeding.

By letter dated March 18, 2021, the Respondent Joseph Mattina, a Code Compliance Officer for the Town, noted the following issues with the application.

1. At least 3 variances will be required from the Town of Newburgh Zoning Board of Appeals before your application is reviewed or approved by the building department.
 - 185-23-B-12 Requires a 60' setback to the property line
 - 185-1-A-4: Discontinuance of a non-conforming use (1 year time limit)
 - 185-19-C-1: Shall not increase the degree of non-conformity. (Larger home)
2. Orange County requires all electricians be licensed by the county. Supply a copy of the electrical license for the file.
3. Supply state certification for manufacture homes.
4. The accessory building requires a separate application and permit.
5. The deck plans are from an outdated building code.
6. The plans also lack details. Examples
 - The deck piers are frost protected, the stairs are not
 - No lateral load details
 - No guard details
 - 2020 RCNYS requires 14" minimum sono tubes (informational)
 - No solid blocking over girder due to cantilever.

- Will toe nailing the joist provide the required wind load design of R301.1
- Show mechanical connection details all bearing points
- Stair illumination

By letter dated April 26, 2021, the ZBA denied the permit, stating: "To replace a manufactured home on your property in the Town of Newburgh, you must obtain a variance from the Zoning Board of Appeals." Appended to the denial was an application for a variance, and a letter from the Respondent Town of Newburgh Code Compliance Department (by Mattina) stating:

"Town of Newburgh Municipal Code: 1) 185-23-B-(12). All mobile homes and other structures shall be set back at least 60 feet from the right-of-way line of any public street or property boundary."

In May of 2021, the Petitioner commenced the proceeding at bar to vacate and annul the denial of the permit, and to compel the Respondents to issue the permit.

As a first cause of action, the Petitioner noted that the entire property was used as a manufactured home park prior to the enactment of the Town of Newburgh zoning code. Thus, the proposed use constituted a pre-existing non-conforming use of the property, which it had a constitutional right to continue.

Here, the Petitioner asserted, the Respondents improperly denied a building permit because they focused solely on the use of the pad at issue (5 Robin Lane), rather than on the use of the property as a whole, as required under the law.

As a second cause of action, the Petitioner alleged that the denial of a permit violated Section 185-19 of the Town of Newburgh Zoning Code, which expressly permitted the continued use of pre-existing non-conforming uses of property.

As third cause of action, the Petitioner alleged that the Respondents violated its substantive due process rights guaranteed by the 14th Amendment of the U.S. Constitution and Article I, § 6 of the New York State Constitution, and that the Respondent should be ordered to issue the building permit and to pay the Petitioner damages, interest and attorneys' fees pursuant to 42 U.S.C. §§1983 and 1988.

The Respondents, in their answer, allege, *inter alia*, that the set backs for the proposed home will be only 26 to 27 feet away from the property line; whereas the Town of Newburgh Municipal Code, Section 185-23-B(12) requires mobile homes to be set back at least 60 feet from the right-of way line of any public street or property boundary.

In opposition to the petition, the Respondents submitted an affidavit from Joseph Mattina (*supra*).

Mattina noted that he understood that the Petitioner's use of the mobile home park was a pre-existing non-conforming use. However, he asserted, in comments he made on March 18, 2021, (*supra*) he identified several deficiencies in the application, including the need to obtain a variance from the current 60' set back requirement for the new, larger trailer home, and for insufficient deck plans, which referred to the prior, outdated building code.

Further, he noted, the Petitioner proposed replacing an existing manufactured home with a larger one that will be only 26 to 27 feet away from the property line. Thus, the proposed new home would be even closer to the property line than the prior structure, which was also not in compliance with the Town code, and therefore will increase the pre-existing non-conformity, contrary to the Code.

Thus, he asserted, the denial of the Petitioner's application was proper under the Town

Code.

In reply, the Petitioner submitted an affidavit from Terri Zeno, the General Manager of Bottini Properties LLC, which is the management company for the Petitioner.

Zeno noted that the manufactured home of the proposed new tenant for 5 Robin Road is 16' x 60', which is approximately 960 square feet. The prior tenant's home was 12' x 65', or approximately 780 square feet.

Zeno asserts that, in his capacity as General Manager of the property, he was aware that manufactured homes measuring 12' x 65' are no longer the industry standard. Rather, a purchaser would need to pay to have a custom home constructed to fit that specification. Zeno opined that, because manufactured homes constituted an affordable housing option, it was "very unlikely" that a tenant could be found who would be willing to pay more for a smaller custom home to match the size of the former home.

Finally, he noted, the previous home on the pad also violated the Town of Newburgh's setback requirements.

The Court's Prior Determination

By Decision and Order dated September 7, 2021, the Court held the matter in abeyance and directed further clarification and development of the record.

First, the Court noted, although Mattina identified various issues with the Petitioner's permit in his initial letter (*supra*), the only basis for the denial of the permit cited in the letters dated April 26, 2021, and April 27, 2021, (*supra*) was that the proposed placement of the home would violate Town of Newburgh Municipal Code 185-23-B-(12), which concerned set-backs, not non-conforming uses.

Further, the Court noted, in the ZBA's letter of April 27, 2021, there was no indication that a hearing was ever held as a predicate for the denial letter.

Moreover, the Court noted, it did not appear disputed that the property at issue was a pre-existing non-conforming use, and the Respondents did not identify the reason or reasons why they concluded that the new zoning code nonetheless applied to the property.

Further, the Court held, it required clarification on the placement of the home on the lot itself, the home's relation to the lot lines, and how the Respondents measured the degree of non-conformity to the Town of Newburgh Municipal Code 185-23-B-(12). Indeed, the Court held, at a minimum, it would be appear that a map of the current mobile home park, the location of the pads, and their proximity to the property line, both now and at the time of the adoption of the zoning and set back Code provisions, would be essential for the Town to make such a determination and/or a predicate for the denial of Petitioner's application.

By letter dated October 7, 2021, the Respondents inquired with the Court whether they should make part of the record a map submitted to the Town by the Petitioner, date stamped March 12, 2021, which depicted the lot lines, locations and dimensions of the proposed new home at issue.¹

The Further Proceedings

On or about January 12, 2022, the Petitioner filed an appeal of the denial of its permit with the ZBA.

By letter dated March 10, 2022, the ZBA asserted that it had received a "mailing for a

¹ The appended map has various handwritten calculations which appear to relate to the calculation of the non-conformity to the set back requirements. The author of the same is not indicated. The calculations appear to conclude that there is 55.56% variance from the code.

partial application to the ZBA.” However, the letter noted, the ZBA had still “not received the remainder of the application in order to put you on an agenda.” Thus, it had “enclosed a complete packet along with a checklist and instructions as to what is needed.”

The letter sought additional information, including:

- a. plot plan, eleven (11) copies drawn to scale;
- b. deed or certified copy thereof;
- c. assessor's list of property owners within 500 feet of property;
- d. four photographs taken at different angles; and
- e. short environmental assessment form.

In addition, the letter directed the Petitioner to send notice of the application to property owners within 500 feet of the property, to post signs and to provide updated notices “if there is any change to the information contained in the original notice.”

In April of 2022, the Petitioner filed an Amended Petition in this proceeding. In the same, the Petitioner reiterated the prior allegations *supra* and set forth the following additional allegations.

On March 14, 2022, counsel for the Petitioner received the letter dated March 10, 2020, *supra*, from the ZBA. “The letter ignored information provided with the appeal and erroneously claimed that additional information was required to process Petitioner's appeal of the building permit denial.” Further, the letter sought additional irrelevant information (*supra*), and directed, *inter alia*, written notices to nearby property owners.

The Petitioner argued that the information demanded was irrelevant to a determination of Petitioner's appeal and/or was duplicative on information contained in Petitioner's original

application.

Indeed, the Petitioner asserts, the ZBA's demands will, in effect, compel the Petitioner to comply with the procedures for obtaining a variance, even though it is not disputed that the proposed use of the property is a continuation of a pre-existing nonconforming use. Thus, a variance is not needed. Accordingly, the Petitioner notes, the Amended Petition adds a cause of action sounding in mandamus to compel the Respondents to issue the permit.

In support of the Amended Petition, the Petitioner submits a memorandum of law.

In the memorandum, the Petitioner notes that, in its order dated September 7, 2021, (*supra*) the Court specifically directed that certain issues be clarified and developed. Consequently, the Petitioner filed an appeal with the ZBA (*supra*).

However, the Petitioner asserts, the ZBA, rather than address the issues identified, sent the letter dated March 14, 2022, (*supra*) seeking additional information. This was error, as no additional or new information was needed. Further, the Petitioner argues, the information being requested was not relevant to a determination of Petitioner's appeal or the issues raised by the Court.

In addition, it asserts, the ZBA, without any basis, directed the Petitioner to send notices to nearby property owners, to post signs and to provide updated notices.

In sum, the Petitioner argues, the ZBA refused to act upon the appeal filed by Petitioner, and to obey the Court's directives.

As legal argument, the Petitioner notes that nonconforming uses and structures, are, as a general rule, constitutionally protected and permitted to be continue. Indeed, it notes, section 185-19(A), Town of Newburgh Zoning Code expressly provides that a "nonconforming use may

continue indefinitely.”

Thus, here, it argues, the proposed use of the pad is a continuation of a pre-existing nonconforming use, and must be allowed to continue.

The Petitioner asserts that there is no support in the record for the Respondents’ implicit assumption/contention that such use was abandoned or discontinued prior the application at bar.

Further, the Petitioner notes, although the Respondents denied the building permit on the ground that the new home violated that Town’s current set back requirements, the previous home also failed to comply with the same.

Moreover, the Petitioner asserts, although Mattina argues that the denial was proper because the replacement home was “larger” than the previous tenant’s home, this determination is in error. Rather, the Petitioner argues, in making such a determination, the Respondents must consider the whole of the mobile home park; that is, all of the 37 pads; not just the pad at issue. Viewed thus, the Petitioner asserts, the proposed use of the pad at issue is not an expansion of a pre-existing use. Indeed, the Petitioner notes, it is not seeking, for example, to build additional pads on the Property.

In sum, the Petitioner argues, other than stating that the new home is “larger,” the Respondents never explained how they concluded that the new home would expand the pre-existing non-conforming use of the property. Indeed, the Petitioner notes, the pad will remain a one-family home. Thus, the occupancy of the pad will not increase.

In any event, the Petitioner asserts, “[a]t best, the increase in non-conformity, which at most would be the length of an arm, is de minimis and does not a meaningfully expand Petitioner’s pre-existing use.”

More importantly, the Petitioner argues, manufactured homes that are the same size as the previous home are no longer the industry standard. Thus, "the practical effect of the challenged building permit denial is the unconstitutional termination of the entirety of Petitioner's pre-existing use, decimating the value of the Real Property."

In addition, the Petitioner asserts, the ZBA's refusal to consider the Petitioner's appeal of the denial of the building permit frustrated the Court's remittal of this case. As a result, none of the questions posed by the Court in its September 7, 2021, Decision and Order can be answered.

Moreover, it argues, the refusal furthered the Respondents' attempt to impose its zoning laws in violation of Petitioner's constitutionally vested rights.

Thus, the Petitioner asserts, mandamus lies.

Indeed, the Petitioner argues, the "one size fits all" appeal process imposed by ZBA is inappropriate in this case. For example, it asserts, no purpose is served by requiring four photographs of a vacant pad, and no statute requires the filing of an environmental assessment form as a pre-condition for the issuance of a building permit to maintain an existing use.

Indeed, the Petitioner opines, the true reason for the Respondents' demand for irrelevant documents is to prevent or delay recognition of the undisputed fact that Petitioner's use of the Property as the site of a single-family manufactured home is a protected pre-existing non-conforming use.

Further, the ZBA's requirement that the Petitioner send notices to nearby property owners is contrary to Town Law §267-a(7), which is applicable to appeals and only requires that "public notice of such hearing by publication in a paper of general circulation in the town at least five days prior to the date thereof."

Here, it asserts, there is no authority for the more onerous and expensive procedures demanded by the ZBA, as nearby property owners have no right to be heard on the issuance of a building permit. Indeed, the imposition of such onerous notice procedures "is a transparent attempt to impose the variance rules upon Petitioner."

In sum, the Petitioner argues, the Court should annul the ZBA's denial of the permit and compel the ZBA to issue the same, and should award the Petitioner damages, interest and attorneys' fees.

The Respondents move to dismiss the Amended Petition.

In support of the motion, the Respondents submit an affirmation from Joseph Mattina.

Mattina avers that, as the Code Compliance Officer a/k/a Building Inspector for the Town of Newburgh since May of 1998, he was familiar with the New York State Building Code and the Town's zoning and related laws. His duties included, *inter alia*, reviewing and processing building permit applications, reviewing plans and drawings, performing inspections, and issuing permits and certificates of occupancy, among other things.

He was personally familiar with the Petitioner's property and application.

He notes that he understands that the Petitioner's trailer park is a pre-existing non-conforming use of the property.

However, he asserts, here, the Petitioner seeks to replace a pre-existing home with a larger, wider modular house, pad and deck, to wit: A 16' by 60' manufactured home with a 10' by 10' deck, that will be located only 26 to 27 feet away from the property line. This would increase the percentage of existing non-conformance to 56%. He notes that he was familiar with, and photographed, the existing home, which is smaller than the proposed home and has a smaller

deck. Mattina asserts that the proposed new home would violate various provisions of the Town Code.

For example, Section 185-23-B(12) requires mobile homes to be set back at least 60 feet from the right-of way line of any public street or property boundary, and section 185-19(B) provides that pre-existing non-conforming structures cannot be enlarged, and that the degree of non-conformity increased, without obtaining an area variance from the ZBA.

Here, he notes, in the comments he sent to the Petitioner on March 18, 2021, (*supra*) he set forth several deficiencies in the application, including, *inter alia*, the need to obtain from the ZBA an area variance for the new, larger trailer home. The Petitioner did not respond to the letter. Therefore, on April 26, 2021, he issued a Notice of Disapproval of Petitioner's Application. The denial was mailed by letter dated April 27, 2021, which explained to the Petitioner how to apply for a variance from the ZBA. However, the Petitioner did not apply for a variance.

In sum, Mattina argues, the Petitioner's remedy is to apply to the ZBA for a variance, and to provide proper complete plans in accordance with the current building code. Indeed, he asserts, several other trailer parks in the town under similar circumstances have applied for and received area variances in accordance with the ZBA's procedures.

In further support of the motion, the Respondents submit an affidavit from Darrin J. Scalzo, the Chairman of the ZBA.

Scalzo notes that the ZBA is responsible for interpreting the town's zoning laws and ordinances, deciding administrative appeals from the planning board and code compliance office or from their decisions, and considering applications for area and use variances, and for special

use permits, among other tasks.

Scalzo notes that the ZBA's application forms include a request for specific information and a checklist setting forth the documents the ZBA requires in order to make an informed review, including an environmental assessment form ("EAF"), as the EAF contains generally all the useful and necessary information relating to the property, and its potential impact, or lack of impact, on neighboring properties or the environment, and whether in any given situation any environmental impact statement might be required, or dispensed with as unnecessary. Plots and surveys are also necessary to enable the ZBA to conduct a thorough examination of the proposed project and to understand the issues involved.

Further, he asserts, as a matter of public policy and local law, the ZBA requires written notice to be given to nearby property owners, as they have a right to be informed, and to be heard, regardless of the specific relief being requested by the claimant.

In addition, there is also a small filing fee charged to all applicants.

Here, he notes, the Petitioner seeks to replace an existing pad and home with a larger pad and home, and a larger deck closer to the property line. The permit was denied by Mattina.

Thereafter, he asserts, the Petitioner submitted only a partially completed application form to the ZBA seeking to annul the determination. However, he avers, the Petitioner did not provide the required documents, nor remit the required filing fee.

Accordingly, he notes, the ZBA provided the Petitioner with the required forms and instructions. However, the Petitioner did not respond, nor file the required documents, nor pay the required filing fee.

Accordingly, he asserts, the ZBA had not taken any action with respect to the project.

In further support of the motion, the Respondents submit an affidavit from Siobhan Jablesnik, the Acting Secretary for the ZBA.

Jablesnik notes that she was familiar with the Petitioner's application, and Mattina's disapproval of the same.

She asserts that, in January 2022, the ZBA received a partially completed application from the Petitioner. She telephoned the Petitioner and explained that the application was incomplete, and that the requested information needed to be filed to place the matter on the ZBA's agenda. However, she avers, the Petitioner stated that it did not see the need to submit a completed application, the documents requested, or pay the filing fee.

When she received no further communication from the Petitioner, she prepared a letter, dated March 10, 2022, in which she enclosed a complete packet along with a checklist and instructions as to what is needed along with the fee schedule. She also invited the Petitioner to call with any questions or for further guidance. However, she asserts, she did not receive any response to the letter, nor any further documents, nor the required filing fee.

In a memorandum of law, the Respondents assert that, as a threshold issue, the Petitioner "lays down the false premise on which it builds its entire case: that by virtue of its pre-existing non-conforming use as a mobile home trailer park it should be entitled to pick and choose between the zoning regulations it likes and does not like, and construct new pads and homes anywhere on its lot regardless of the Town's set-back requirements." If this logic were adopted, the Respondents argues, "the Town would have no right to prevent Petitioner from placing its new pad and home even one foot from the property line if it so desired."

The Respondents note that the Petitioner admits that it seeks to replace the existing pad

with a larger pad and larger home closer to the property line and roadway. Further, that the new home will be sixteen feet wide versus twelve feet wide, and occupy a total of 960 square feet compared to 780 square feet occupied by the former home. The site plans also show a new, larger deck as well (10 feet by 24 feet), which will bring the new structure to within approximately 26 feet from the property line abutting Wells Road. Indeed, they note, as is shown in a photograph of the prior home, the original deck was much smaller in area as compared to the proposed new deck.

Thus, the Respondents assert, the new pad, home and deck will result in an even greater decrease in distance to the property line, and thus an increase in the degree of non-conformity with the legal set-back distance of 60 feet.

However, the Respondents note, despite the same, the Petitioner refused to apply for an area variance with the ZBA; or to pay the filing fee and submit the documents requested by the ZBA to file its administrative appeal from the building inspector's denial of a permit.

Therefore, they argue, the first two causes of action must be dismissed as a matter of law because the Petitioner failed to exhaust its administrative remedies.

Further, the Respondent asserts, the Petitioner "has utterly failed to plead and present facts to support its constitutional due process claim, requiring dismissal of its third cause of action."

In addition, they argue, contrary to the Petitioner's contentions, the basis for the denial of the permit was not a finding that the pre-existing non-conforming use was discontinued or abandoned.

Further, they assert, the Petitioner, in its original petition and memorandum of law,

erroneously insisted that it was not required to exhaust its administrative remedies because "the Newburgh Zoning Board of Appeals does not have jurisdiction to reverse denials of building permits"; "the Town of Newburgh enabling statute lacks a general grant of authority to hear appeals from the denial of building permits"; "an appeal to the Zoning Board of Appeals would be futile because the relief being sought is 'wholly beyond' the grant of power to the Zoning Board of Appeals"; and "an appeal to the Board of Zoning Appeals would cause Petitioner irreparable injury." These arguments, the Respondents opine, explain why the Petitioner subsequently made only a token attempt to file an administrative appeal, which it aborted.

Further, the Respondents argue, the Petitioner also takes the position that "the zoning code is inapplicable to the Real Property" and, "astonishingly," that "requesting a variance would be a concession, or at the very least an admission, that the zoning code was applicable to the Real Property". The Respondents assert that the "absurdity, and irony, of Petitioner's position is shown by the fact that Petitioner, despite its belief it does not have to obey the zoning code, nonetheless submitted the application for a building permit which is the genesis of this proceeding."

Moreover, the Respondents note, in the Petitioner's new submissions, it "understandably drops such explicit misstatements of New York State Town Law and the Town of Newburgh's Zoning Code and focuses instead on conclusory statements of unconstitutionality."

Similarly, the Respondents argue, the Petitioner also incorrectly argues that the size and location of the new structure would increase the existing non conformity only "the length of an arm" and would not "meaningfully expand Petitioner's pre existing use."

The Respondents note that, although the Petitioner does not claim that the Town's Mobile

Home Court law is unconstitutional per se, it claims the its application to its permit constitutes a deprivation of its particular property rights under the 14th Amendment as applied to it. However, the Respondents argue, the Petitioner has presented no proof that the Town's set-back requirements have singled out the Petitioner, or are being applied in a discriminatory fashion. Indeed, they contend, the Petitioner does "not even come close to demonstrating in what manner the Town's Code has wrongfully divested Petitioner of its property rights. There has been no 'taking' of Petitioner's property nor any diminution in the value of the property; nor can the underlying set-back requirement be viewed as 'an ordinance which permanently so restricts the use of property that it cannot be used for any reasonable purpose,' in order to be an invalid exercise of the police power under the Due Process Clause."

Finally, the Respondents argue, in any event, the Petitioner's allegations do not give rise to any claim for monetary damages.

In opposition to the Respondents' motion and in reply, the Petitioner submits an affidavit from Bottini (*supra*).

Bottini avers that the infrastructure installed and maintained by Petitioner (landscaping, roads, sewer piping, private utility lines water treatment facilities) benefits the entire Real Property. He asserts that, from April 2016 through the present, the Petitioner spent over \$170,000.00 to maintain the common areas and infrastructure at the manufactured home park. These costs included landscaping, tree maintenance, sewer repair and maintenance, snow plowing, road repair and maintenance, replacement of utility poles and repairs of street lighting.

In a memorandum of law the Petitioner argues that, as the Respondents' submissions make clear, any further appeal to the ZBA would be futile. Indeed, it asserts, the Respondents'

“new defense, which could have been advanced in response to the original Petition, is that Petitioner is seeking to expand a building on the Real Property and not continue the use of the Real Property as a manufactured home park. The question now squarely presented is whether Petitioner’s use of the Real Property as a manufactured home park extends to the border of the property.”

However, the Petitioner argues, the “trivial extension of the replacement manufactured home is insufficient to overcome the law’s recognition that Petitioner’s protected activity extends to the border of its property and therefore cannot be subject to later enacted set back provisions.” Indeed, it contends, “the Respondents’ invocation of the bulk area rules is simply an attempt to extinguish Petitioner’s protected use of the Real Property.”

Finally, the Petitioner argues, the Respondents “completely ignore that they are playing with real people’s lives. The manufactured home that is the subject of the building permit application was ordered by an actual tenant and was delivered to the Real Property after the filing of the Amended Petition. There is a real person waiting to occupy this home.”

Indeed, it notes, by law, the Petitioner cannot mandate the details of the homes purchased by its tenants. Rather, the structural design of manufactured homes is regulated by the United States Department of Housing and Urban Development in 24 C.F.R. § 3280.1, et seq. For example, 24 C.F.R. § 3280.101, et seq. sets forth the requirements for the interior construction of manufactured homes (rooms, hallways, interior passages, etc).

Further, New York Real Property Law Section 233(h) provides, in pertinent part:

h. No manufactured home park owner shall:

4. Require a manufactured home owner or a prospective manufactured home owner to

purchase his or her manufactured home from the manufactured home park owner or operator, or from any person or persons designated by the manufactured home park owner or operator. Nothing herein shall be construed to prevent a manufactured home park owner or operator from requiring that any new manufactured home to be installed in his or her manufactured home park comply with the rules and regulations of said manufactured home park or conform to the physical facilities then existing for installation of a manufactured home in said manufactured home park.

N.Y. Real Prop. Law § 233.

The New York Attorney General has interpreted this law as follows:

It is illegal for a manufactured home park owner to require a person to purchase a manufactured home from him, her or from any particular dealer designated by the park owner in order to rent a space in his park. This protection should especially help those manufactured home owners, who want to upgrade their homes, from paying exorbitant prices. (Real Property Law § 233(h)(4)). [Emphasis added.]

Office of the New York State Attorney General, "Manufactured Home Tenant's Rights", at 11.

In addition, pursuant to Real Property Law Section 233(h), the Petitioner may not require the purchase of a home the size of the previous home. The proposed replacement home for 5 Robin Rd. "conform[s] to the physical facilities then existing for installation of a manufactured home" at the Real Property. *See Real Property Law Section 233(h)(4)*. The Attorney General's office interpretation prohibits interference in "upgrades" of home, which obviously can include size characteristics. Thus, the size of a tenant's home is not a part of Petitioner's business or protected nonconforming use because Federal and New York State law prohibit Petitioner from exercising any control over the size or structure of the manufactured homes.

The Petitioner notes that the Respondents also argue that Petitioner's claim against the ZBA must be dismissed because it did not pay the filing fee. However, the Petitioner avers, it did in fact pay the filing fee.

Finally, the Petitioner notes, the ZBA failed to make any factual findings in support of its

determination. Ordinarily, such a deficiency would require that the matter be remanded to the ZBA as proper judicial review of such determinations is impossible unless the zoning authority makes findings of fact and delineates those findings which provided the basis for its decision. However, here, it argues, because the record clearly indicates that the Board's action in denying the Petitioner's permit is contrary to law, the matter should not be remanded to the Board to go through the formality of making factual findings in support of a determination which cannot be sustained.

Discussion/Legal Analysis

Initially, the Court notes, the parties did not follow the Court's directives in the prior order *supra*. The clear purpose of the same was to develop the factual record as to the application as it existed. In particular, facts such as the exact placement, etc. of the proposed home, and the general layout and dimensions of the Petitioner's property in general. However, upon remittitur, the Respondents, in effect, sought to compel the Petitioner to file a complete application which might be required for a variance. This, in effect, assumes one of the very matters at issue, to wit: whether the proposed use was a mere continuation of a pre-existing nonconforming use, which would require no variance, or whether it was a new or impermissibly expanded pre-existing use of the property, which would.

Regardless, the Court must decide the issues presented on the record made, which is sparse.

In general, a use of property that existed before the enactment of a zoning restriction that prohibits the use is a legal nonconforming use, but the right to maintain a nonconforming use does not include the right to extend or enlarge that use. *Sand Land Corp. v. Zoning Bd. of*

Appeals of Town of Southampton, 137 A.D.3d 1289 [2nd Dept. 2016]. Indeed, because nonconforming uses are viewed as detrimental to zoning schemes, public policy favors their reasonable restriction and eventual elimination. Further, in keeping with the sound public policy of eventually extinguishing all nonconforming uses, the courts will enforce a municipality's reasonable circumscription of the right to expand the volume or intensity of a prior nonconforming use. *Sand Land Corp. v. Zoning Bd. of Appeals of Town of Southampton*, 137 A.D.3d 1289 [2nd Dept. 2016]. There is no *per se* or general rule concerning *de minimis* or minor variances. Rather, the case law suggests that a decision concerning whether a proposed use is new use or an impermissible expansion, etc. of a pre-existing, nonconforming use is *sui generis* and fact driven. *see e.g.*, *550 Halstead Corp. v. Zoning Bd. of Appeals of Town/Village of Harrison*, 1 N.Y.3d 561 (2003); *Sand Land Corp. v. Zoning Bd. of Appeals of Town of Southampton*, 137 A.D.3d 1289 [2nd Dept. 2016]; *Piesco v. Hollihan*, 47 A.D.3d 938 [2nd Dept. 2008]; *Smith v. Board of Appeals of Town of Islip*, 202 A.D.2d 674 [2nd Dept. 1994]; *Garcia v. Holze*, 94 A.D.2d 759 [2nd Dept. 1983].

In general, the determination of a zoning board regarding the continuation of a preexisting nonconforming use must be sustained if it is rational and supported by substantial evidence, even if the reviewing court would have reached a different result. *Matter of P.M.S. Assets v. Zoning Bd. of Appeals of Vil. of Pleasantville*, 98 N.Y.2d 683; *Nabe v. Sosis*, 175 A.D.3d 500 [2nd Dept. 2019]; *Tavano v. Zoning Bd. of Appeals of Town of Patterson*, 149 A.D.3d 755 [2nd Dept. 2017]; *Sand Land Corp. v. Zoning Bd. of Appeals of Town of Southampton*, 137 A.D.3d 1289 [2nd Dept. 2016].

Further, a litigant is required to address his or her complaints initially to administrative

tribunals, rather than to the courts, and to exhaust all possibilities of obtaining relief through administrative channels before appealing to the courts. *Kaufman v. Incorporated Village of Kings Point*, 52 A.D.3d 604 [2nd Dept. 2008].

Review of an administrative determination is limited to the grounds invoked by the agency, and a reviewing court which finds those grounds insufficient or improper may not sustain the determination by substituting what it deems to be a more appropriate or proper basis. *Rizzo v. New York State Div. of Housing and Community Renewal*, 6 N.Y.3d 104 (2005); *Matter of Parkmed Assoc. v New York State Tax Commn.*, 60 N.Y.2d 935 (1983). Thus, in a CPLR article 78 proceeding, the court's review is limited to the arguments and record adduced before the agency. *Kelly v. Safir*, 96 N.Y.2d 32 (2001); *Kaufman v. Incorporated Village of Kings Point*, 52 A.D.3d 604 [2nd Dept. 2008]. The court cannot rely upon post-determination submissions. *Kelly v. Safir*, 96 N.Y.2d 32 (2001).

Here, in the initial letter from Mattina, he identified three zoning code provisions which required a variance for the project.

However, in the denial letter from the ZBA, it cited only one ground to deny the permit, to wit:

“Town of Newburgh Municipal Code: 1) 185-23-B-(12). All mobile homes and other structures shall be set back at least 60 feet from the right-of-way line of any public street or property boundary.”

Thus, this is the sole ground upon which the ZBA's determination may be sustained.

However, the Court notes, although directed to, and afforded an opportunity to develop the record, the ZBA has not identified any evidence which supports its conclusion that the new home will result in an increase in non-conformity with required set backs. For example,

significantly, nowhere in the record is there any map, etc. showing the placement of the prior home, or any measurements, etc., which demonstrate the prior home's degree of nonconformity with the current zoning code as to set backs. Thus, it is unclear as to how the Respondents concluded that the new home would increase such non-conformity.

Indeed, based on the limited record made, the Court surmises that the Respondents concluded that the proposed new home would necessarily increase the non-conformity with the set back provisions of the current code due to the fact that the new home is wider than the prior home. However, the Court notes, this is not necessarily so.

The maps showing the placement of the new home on the property indicate that neither the pad nor the home run parallel to the adjacent (eastern) property line (NYSCEF items ## 22, 30). Rather, the home slants easterly from south to north. The prior home was 65 feet long; whereas the proposed home is 60 feet long. Consequently, the prior home may have actually been closer to the property line on its northern end.

Regardless, the Court notes, there is no basis in the record that supports a finding the proposed home will increase the noncompliance with the current zoning code set backs.

Thus, the determination may not be sustained.

Further, the Court finds that the Petitioner exhausted its administrative remedies concerning this issue, given the Court's prior directions *supra* to develop the record, and the Petitioner's filing of an appeal before the ZBA for that purpose.

However, the Court will not direct the ZBA to issue the permit. Rather, the matter is remitted to the ZBA for further proceedings consistent with its decision, and for the imposition of pertinent conditions or requirements. *Castle Properties Co. v. Ackerson*, 163

A.D.2d 785 [3rd Dept. 1990]. That is, the ZBA is not precluded from reviewing the application, other than whether the proposed home itself constitutes a new use of the Property, or an impermissible expansion, etc. of a pre-existing nonconforming use of the Property. That issue is decided.

Finally, the Petitioner has demonstrated no basis for the imposition of monies damages or attorneys' fee, and none are awarded.

Accordingly, and for the reasons cited herein, it is hereby,

ORDERED, the petition and the motion are decided as set forth herein.

The foregoing constitutes the decision and order of the court.

Dated: June 27, 2022
Goshen, New York

ENTER



HON. ROBERT A. ONOFRY, J.S.C.

TO: For the Petitioner
Wichler & Gobetz, P.C.
Office & P.O. Address
400 Rella Boulevard, Suite 125
Suffern, New York 10901

Of Counsel:

SAFFIOTI & ANDERSON
Office & P.O. Address
5031 Rt. 9W
Newburgh, New York 12550

For the Respondent
Rider, Weiner & Frankel P.C.
Office & P. O Address
655 Little Britain Road
New Windsor, New York 12553

THIS IS NOT A BUILDING PERMIT

APPLICATION #21-0224

5 Robin Rd

Town of Newburgh

Code Compliance Department

21 Hudson Valley Professional Plaza Newburgh, NY 12550
845-564-7801 Phone 845-564-7802 Fax

MAILED TO: Bottini Properties LLC 18 Clinton Street , Wappingers Falls, NY 12590 - 845-297-2109 2025

PROJECT: Replacement of Manufactured (Mobile) Home - 16' x 60' Single Wide.

SBL: 39-1-42

APPLICATION DATE: 03/17/2021 Review Date: 3-18-2021

Residential: All smoke and co alarms shall be upgraded.

Commercial: Carbon Monoxide Detection is required. Section 915.3 2017 NY Supplement.

ORANGE COUNTY REQUIRES ALL ELECTRICIANS TO BE LICENSED

1. At least 3 variances will be required from the Town of Newburgh Zoning Board of Appeals before your application is reviewed or approved by the building department.

- 185-23-B-12 Requires a 60' setback to the property line
- 185-1-A-4: Discontinuance of a non-conforming use (1 year time limit)
- 185-19-C-1: Shall not increase the degree of non-conformity. (Larger home)

2. Orange County requires all electricians be licensed by the county. Supply a copy of the electrical license for the file.

3. Supply state certification for manufacture homes.

4. The accessory building requires a separate application and permit.

5. The deck plans are from an outdated building code.

6. The plans also lack details. Examples

- The deck piers are frost protected the stairs are not
- No lateral load details
- No guard details
- 2020 RCNYS requires 14" minimum sono tubes (informational)
- No solid blocking over girder due to cantilever.
- Will toe nailing the joist provide the require wind load design of R301.1
- Show mechanical connection details all bearing points
- Stair illumination

Revisions:

Joseph Mattina
Code Compliance

State of New York

Manufactured Housing Certificate

Bottini Properties, LLC
2785 West Main St, Wappingers Falls, NY 12590

"has satisfied all the requirements within the provisions of Article 21-B of the Executive Law of New York and Part 1210 of Title 19 of the New York Codes, Rules and Regulations, and is hereby certified as a Certified Retailer of Manufactured Homes."

I.D.# IRET00241

Expires: 8/17/2024



Whitney A. Clark, ESQ
*Deputy Secretary of State for
Business Development*