

*Andrew J. Zarutskie, Town Clerk
Town of Newburgh
1496 Route 300
Newburgh NY 12550
Tel.(845) 564-4554*

AGENDA

**PUBLIC TOWN COUNCIL MEETING
Monday, October 7, 2013
7:00 p.m.**

- 1. ROLL CALL**
- 2. PLEDGE OF ALLEGIANCE TO THE FLAG**
- 3. MOMENT OF SILENCE**
- 4. CHANGES TO AGENDA**
- 5. COMMENTS ON AGENDA ITEMS**
- 6. RESOLUTION to Schedule Public Hearing for 2014 General and Highway Budgets**
- 7. RESOLUTION of Referral for Local Law (Cargo Container)**
- 8. POLICE: Purchase of Vehicles**
- 9. JUSTICE COURT: 2013-2014 Justice Court Assistance Program (JCAP) Grant**
- 10. FLEET MAINTENANCE: Award of Bid for Accessory Storage**
- 11. ANNOUNCEMENTS**
- 12. PUBLIC COMMENTS**
- 13. ADJOURNMENT**

6. RESOLUTION to Schedule Public Hearing for 2014 General and Highway Budgets

10-7-13

6

DRAFT

At a meeting of the Town Board of the Town of Newburgh, held at the Town Hall, 1496 Route 300, in the Town of Newburgh, Orange County, New York on the ___th day of October, 2013 at 7:00 P.M., Prevailing Time.

PRESENT:

- Wayne C. Booth, Supervisor
- George Woolsey, Councilman
- Gilbert J. Piaquadio, Councilman
- Elizabeth J. Greene, Councilwoman
- Ernest C. Bello, Jr., Councilman

RESOLUTION CALLING PUBLIC HEARING ON PRELIMINARY 2014 TOWN OF NEWBURGH BUDGET

Councilman\Councilwoman _____ presented the following resolution which was seconded by Councilman\Councilwoman _____.

WHEREAS, the Town Board of the Town of Newburgh has met and considered the tentative and preliminary budget for the fiscal year beginning January 1, 2014; and

WHEREAS, the Town Board of the Town of Newburgh desires to schedule a date and time for the Public Hearing to be held on November 4, 2013 at 7:00 p.m.; and

WHEREAS, the preliminary budget must be filed in the Office of the Town Clerk of the Town of Newburgh at the time of publication of the Notice of Public Hearing;

NOW, THEREFORE, BE IT RESOLVED as follows:

1. That in accordance with the provisions of §106 of the Town Law and other applicable provisions of Law, the preliminary budget for the fiscal year beginning January 1, 2014 shall be filed in the office of the Clerk of the Town of Newburgh where it shall be available for public inspection at or before the time of publication of the

Notice of Public Hearing.

2. The Town Clerk of the Town of Newburgh shall give Notice of such Public Hearing to be held on November 4, 2013 at 7:00 p.m. by publishing notice thereof in the official newspaper of the Town of Newburgh not less than five (5) days prior to November 4 2013, and cause a copy of such notice to be posted on the sign board of the Town of Newburgh not later than five (5) days before November 4, 2014.

3. This resolution shall take effect immediately.

The question of the adoption of the foregoing resolution was duly put to a vote on roll call, which resulted as follows:

George Woolsey, Councilman voting _____
Gilbert J. Piaquadio, Councilman voting _____
Elizabeth J. Greene, Councilwoman voting _____
Ernest C. Bello, Jr., Councilman voting _____
Wayne C. Booth, Supervisor voting _____

The resolution was thereupon declared duly adopted.

I, Andrew J. Zarutskie, the duly elected and qualified Town Clerk of the Town of Newburgh, New York, do hereby certify that the following resolution was adopted at a regular meeting of the Town Board held on October _____, 2013 and is on file and of record and that said resolution has not been altered, amended or revoked and is in full force and effect.

Andrew J. Zarutskie, Town Clerk
Town of Newburgh

7. RESOLUTION of Referral for Local Law (Cargo Container)

10-7-13

7

DRAFT

At a meeting of the Town Board of the Town of Newburgh, held at the Town Hall, 1496 Route 300, in the Town of Newburgh, Orange County, New York on the 7th day of October, 2013 at 7:00 o'clock p.m.

PRESENT:

Wayne C. Booth, Supervisor

George Woolsey, Councilman

Gilbert J. Piaquadio, Councilman

Elizabeth J. Greene, Councilwoman

Ernest C. Bello, Jr., Councilman

RESOLUTION OF TOWN BOARD PROVIDING FOR REFERRAL OF REVISED LOCAL LAW AMENDING CHAPTER 185 ENTITLED 'ZONING' OF THE CODE OF THE TOWN OF NEWBURGH TO ADD CARGO STORAGE CONTAINERS AS A PERMITTED ACCESSORY USE TO CERTAIN USES IN THE B, IB AND I DISTRICTS AND THE LHI OVERLAY DISTRICT AND TO ADD STORAGE BUILDINGS AS A PERMITTED ACCESSORY USE TO OFFICES FOR BUSINESS, RESEARCH AND PROFESSIONAL USES IN THE IB DISTRICT

Councilman/woman _____ presented the following resolution which was seconded by Councilman/woman _____.

WHEREAS, the Town Board of the Town of Newburgh has caused a local law to be prepared amending Chapter 185 entitled 'Zoning' of the Code of the Town of Newburgh to add Cargo Storage Containers as a Permitted Accessory Use to Certain Uses in the B, IB and I Districts and the LHI Overlay District and to add Storage Buildings as a Permitted Accessory Use to Offices for Business, Research and Professional Uses in the IB District; and

WHEREAS, the Town Board directed that copies of the aforesaid local law be forwarded to the Orange County Department of Planning, the Town of Newburgh Planning Board and the Town's Zoning Board of Appeals for their reports; and

WHEREAS, the Town Board considered the reports it received from the Orange County Department of Planning, the Town of Newburgh Planning Board and the Town of Newburgh Zoning Board of Appeals and has caused substantial modifications to be made in the local law,

NOW, THEREFORE, BE IT RESOLVED that copies of the revised local law amending Chapter 185 entitled 'Zoning' of the Code of the Town of Newburgh be forwarded to the Orange County Department of Planning and the Town of Newburgh Planning Board for their reports in accordance with the provisions of the New York State General Municipal Law and the Town of Newburgh Zoning Code; and

BE IT FURTHER RESOLVED, that a copy of the aforesaid revised local law also be forwarded to the Town of Newburgh Zoning Board of Appeals for its comments.

The question of the adoption of the foregoing resolution was duly put to a vote on roll call which resulted as follows:

George Woolsey, Councilman voting _____

Gilbert J. Piaquadio, Councilman voting _____

Elizabeth J. Greene, Councilwoman voting _____

Ernest C. Bello, Jr., Councilman voting _____

Wayne C. Booth, Supervisor voting _____

The resolution was thereupon declared duly adopted.

8. POLICE: Purchase of Vehicles

OCT 9 2013

8

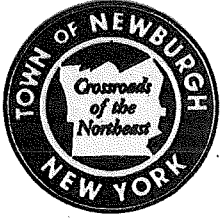

TOWN OF NEWBURGH POLICE DEPARTMENT

300 Gardnertown Road, Newburgh, New York 12550

Michael P. Clancy
Chief of Police

(845) 564-1100
Fax (845) 564-1870

September 30, 2013

To: Town Board

From: Chief Michael Clancy

Subject: Authorization for Purchase of Police Vehicles

I am requesting your authorization to purchase two (2) 2013 Ford Sedan Police Interceptors AWD from New York State Bid # PC65855 at a cost of \$23,274.14 per vehicle and one (1) 2013 Ford Expedition SSV also from New York State Bid # PC65855 at a cost of \$28,396.15 per vehicle for a total cost of \$74,944.43. The funds for these vehicles have been included in the 2013 police budget in the capital account (# 3120.2). I have spoken with Jim Lacolla from Fleet and he concurs with the above purchase.

Sincerely;

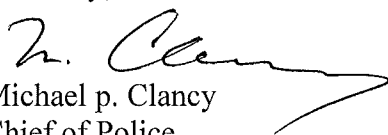
Michael p. Clancy
Chief of Police



71 Marsh Rd East Rochester, NY 14445
7706

Manday September 30th, 2013 8:38 AM

(585) 586-7705 Fax (585) 586-7706

Vehicle Purchase Proposal

Attention: Jim LaColla

Purchase Order#:

Town of Newburgh

Quote# 14695

88 Gardnertown Rd

22539/PC65855 2014 Lot 3 Item 8

Newburgh, NY 12550

Retail Inv: \$27240.70 Dealer Disc: \$1716.16

Phone: 845-561-2288 Fax: 845-561-3975

Mfg Bid Assist: \$2600.00 Options Disc: 8%

Mobile: 845-541-6788 Email:

fleetmaintenance@hvc.rr.com

Item Description	Code	Qty	Your Price	MSRP
2014 Ford Sedan Police Interceptor AWD	P2M	1	\$ 22,924.54	\$ 0.00
Oxford White	YZ	1	\$ 0.00	\$ 0.00
Keyed Alike - 1284x	43B	1	\$ 46.00	\$ 50.00
Noise Suppression Bonds	20P	1	\$ 87.40	\$ 95.00
Rear Console Plate	97D	1	\$ 32.20	\$ 35.00
Rear Door Handles Inoperable / Locks Inoperable	18G	1	\$ 32.20	\$ 35.00
Windows - Rear window power delete, operable from front driver side switches	67D	1	\$ 23.00	\$ 25.00
#1a - Front Headlamp/Police Interceptor Housing Only	13P	1	\$ 110.40	\$ 120.00
Dark Car Feature - Courtesy lamp disable when any door is opened	13C	1	\$ 18.40	\$ 20.00
Term is Net 15 Days A.R.V. Delivery from factory to dealer is estimated at 16-20 weeks. This Quote Expires In 60 Days or final Order date, whichever comes first.	Total Price:		\$ 23,274.14	
Quantity on this Order: 2	Grand Total:		\$ 46,548.28	

Suggested Items Below	Code	Qty	Your Price	MSRP
Police Wire Harness Connector Kit - Front	77E	1	\$ 96.60	\$ 105.00
Police Wire Harness Connector Kit - Rear	51J	1	\$ 119.60	\$ 130.00
Pre-Wiring for grille lamp, siren, and speaker	51G	1	\$ 46.00	\$ 50.00
ESP Powertrain Care 3 Year, 125,000 Miles, \$100.00 deductible AWD Adjusted for Specialty Use Surcharge	Warr	1	\$ 2,164.20	\$ 2,164.20
Center Console with Arm Rest, filler face plates, Cup holders, Power outlets (12V) (Havis)		1	\$ 703.80	\$ 765.00
Space Saver Full partition air bag compatible (Go Rhino)		1	\$ 1,334.00	\$ 1,450.00

To place an order please sign and date this proposal and return it to Van Bortel Ford along with a valid Purchase Order, Voucher, or Letter of Intent. Thank You!

Accepted By: _____ Title _____ Date _____

Van Bortel Ford Inc (WBE) Salesperson: Shane Startzel Quote: 14695 Federal ID: 16-1609363



71 Marsh Rd East Rochester, NY 14445 (585) 586-7705 Fax (585) 586-7706

Monday September 30th, 2013 3:29 PM

Vehicle Purchase Proposal

Attention: Jim LaColla

Purchase Order#:

Town of Newburgh
 88 Gardnertown Rd
 Newburgh, NY 12550
 Phone: 845-561-2288 Fax: 845-561-3975
 Mobile: 845-541-6788 Email:
 fleetmaintenance@hvc.rr.com

Quote# 14700
 22539/PC65855 2014 Lot 3 Item 12
 Retail Inv: \$37320.50 Dealer Disc: \$2287.75
 Mfg Bid Assist: \$7000.00 Options Disc: 8%

Item Description	Code	Qty	Your Price	MSRP
2014 Ford Expedition XL SSV 4WD	U1G	1	\$ 28,032.75	\$ 0.00
Oxford White	Z1	1	\$ 0.00	\$ 0.00
5.4L, FFV, SOHC, V8 Engine	995	1	\$ 0.00	\$ 0.00
6-Speed Automatic Transmission	446	1	\$ 0.00	\$ 0.00
17in St Whl (non EL) (P265/70R17 BSW - 4x2, non EL)/(P265/70R17OWL All-Seas - 4x4, non EL), Cloth 1st Row / Vinyl 2nd Row Seating, 3rd Row Seating Del with Cover/End Cap, Col Shifter and Floor Consol	102A	1	\$ 0.00	\$ 0.00
Front Captains Chairs, Cloth w/Drv Side Power (XL, XLT) XL, XLT	F	1	\$ 0.00	\$ 0.00
Trailer Tow Package - Optional on 100A, EG102A	536	1	\$ 363.40	\$ 395.00
Term is Net 15 Days A.R.V. Delivery from factory to dealer is estimated at 16-20 weeks. This Quote Expires In 60 Days or final Order date, whichever comes first.	Total Price:		\$ 28,396.15	
Quantity on this Order: 1	Grand Total:		\$ 28,396.15	
Suggested Items Below				
Running Boards - Optional on EG102A	186	1	\$ 400.20	\$ 435.00
Powertrain Commercial Business Use Surcharge Required	Warr	1	\$ 100.00	\$ 100.00
Powertrain Warranty 5 year, 100,000 mi \$100.00 Deductible 4x4	Warr	1	\$ 1,232.80	\$ 1,340.00
Powertrain \$0.00 Deductible Surcharge	Warr	1	\$ 115.00	\$ 115.00

To place an order please sign and date this proposal and return it to Van Bortel Ford along with a valid Purchase Order, Voucher, or Letter of Intent. Thank You!

Accepted By: _____ Title _____ Date _____

Van Bortel Ford Inc (WBE) Salesperson: Shane Startzel Quote: 14700 Federal ID: 16-1609363

9. Justice Court 2013-2014 Justice Court Assistance Program (JCAP) Grant

10-7-13



DRAFT

At a meeting of the Town Board of the Town of Newburgh, held at the Town Hall, 1496 Route 300, in the Town of Newburgh, Orange County, New York on the 7th day of October, 2013 at 7:00 P.M., Prevailing Time.

PRESENT:

Wayne C. Booth, Supervisor

George Woolsey, Councilman

Gilbert J. Piaquadio, Councilman

Elizabeth J. Greene, Councilwoman

Ernest C. Bello, Jr., Councilman

RESOLUTION OF SUPPORT
TO CERTAIN INITIATIVES OF THE
JUSTICE COURT OF THE TOWN OF
NEWBURGH IN SUBMITTING AN
APPLICATION FOR THE 2013 JUSTICE
COURT ASSISTANCE PROGRAM (JCAP)

Councilman/woman _____ presented the following resolution which was seconded by Councilman/woman _____.

WHEREAS, the Town of Newburgh Justice Court has taken the initiative of applying for a grant under the 2013 Justice Court Assistance Program (JCAP); and

WHEREAS, the Town of Newburgh Justice Court has provided each member of the Town Council with all of the details regarding this grant application, including the proposed use of any monies granted as a result of this application.

NOW, THEREFORE, BE IT RESOLVED that the Town of Newburgh Town Board, in its capacity as governing body of the Town of Newburgh, does hereby fully and completely support the initiatives of the Justice Court in applying for this grant.

BE IT FURTHER RESOLVED, that the aforesaid resolution shall take effect immediately.

The question of the adoption of the foregoing resolution was duly put to a vote on roll call, which resulted as follows:

George Woolsey, Councilman voting _____

Gilbert J. Piaquadio, Councilman voting _____

Elizabeth J. Greene, Councilwoman voting _____

Ernest C. Bello, Jr., Councilman voting _____

Wayne C. Booth, Supervisor voting _____

The resolution was thereupon declared duly adopted.

STATE OF NEW YORK)
COUNTY OF ORANGE) SS:
TOWN OF NEWBURGH)

I, Andrew J. Zarutskie, Town Clerk of the Town of Newburgh, DO HEREBY CERTIFY that I have compared the foregoing resolution, duly adopted by the Town Board of the Town of Newburgh on the 7th day of October, 2013, and entered in the minutes of the proceedings of said Board, and that the foregoing is a true and correct copy of said resolution and the whole thereof.

IN WITNESS WHEREOF, I have hereunto set my name and the seal of said Town on this _____ day of October, 2013.

Andrew J. Zarutskie, Town Clerk



OCT 9 2013

NEWBURGH TOWN COURT
311 ROUTE 32
NEWBURGH, NEW YORK 12550

9

TELEPHONE (845) 564-7165
FACSIMILE (845) 564-7171

HON. JUDE T. MARTINI
TOWN JUSTICE

HON. RICHARD CLARINO
TOWN JUSTICE

MEMORANDUM

TO: Wayne Booth, Town Supervisor
Ernie Bello, Town Councilman
Elizabeth J. Greene, Town Councilwoman
Gilbert J. Piaquadio, Town Councilman
George A. Woolsey, Town Councilman

FROM: Hon Richard Clarino, Town Justice *rk*
Hon. Jude T. Martini, Town Justice *JM*

DATE: October 2, 2013

SUBJECT: 2013/2014 Justice Court Assistance Program (JCAP)

Attached is information regarding an application for the 2013-2014 Justice Court Assistance Program (JCAP) Grant, which must be submitted by October 15, 2013.

The application must be submitted with a certified copy of a Local Resolution of the Town Board authorizing the application.

We are requesting this matter be placed on the October 7, 2013 agenda for your consideration.

If you require additional information, please feel free to contact either of us directly.

Thank you

Attachment



NEW YORK STATE
Unified Court System

OFFICE OF COURT ADMINISTRATION

RONALD P. YOUNKINS, ESQ.
EXECUTIVE DIRECTOR

EUGENE W. MYERS
CHIEF OF OPERATIONS

NANCY M. SUNUKJIAN, ESQ.
DIRECTOR, OFFICE OF JUSTICE COURT SUPPORT

July 1, 2013

To: All Town and Village Justices,

We are pleased to invite you to apply for a 2013-2014 Justice Court Assistance Program (JCAP) Grant. The State Court System's budget includes \$2.5 million in JCAP funding this fiscal year. The maximum JCAP award is \$30,000 per court. It may be used for a variety of purposes, including office and security equipment, furniture, courtroom and court facility improvements and renovations.

Applications for JCAP Grants may be submitted by the Justice Courts or by Towns and Villages on behalf of the court. Please coordinate your court's application with your clerk(s), Judge(s) and municipality. Applications and accompanying paperwork should be submitted by OCTOBER 15, 2013.

THE APPLICATION ITSELF MUST BE SUBMITTED ONLINE. However, the following items must be submitted either by mail, or faxed to us at 1-518-438-3518, or scanned and e-mailed to jcav@nycourts.gov

- Signature Page ✓
- Board Resolution ✓
- Court's Annual Budget ✓
- Estimates ✓

A link to the online grant application can be found on the Town and Village Courts website at www.nycourts.gov/justicecourts. When you click on the online grant application, you must enter an Account Name - which is "court", and a Password - which is "jcav", all lower case letters, to start the application.

The link directly to the website is:

https://www.nycourtsystem.com/fmi/iwp/cgi?-db=TVJCAP_GRTAPP13_ME.fp7&-loadframes

If you have any questions about JCAP, or if you need assistance completing the application, please contact the Office of Justice Court Support at 1-800-232-0630.

Very truly yours,

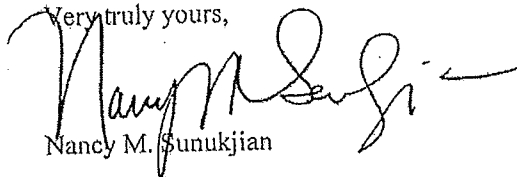

Nancy M. Sunukjian

cc: Hon. Michael V. Coccoma
Ronald P. Younkings, Esq.
Eugene W. Myers
Administrative Judges
Supervising Judges
District Executives

**ITEMS FOR 2013-2014
JCAP GRANT**

ITEM	PRICE	AMOUNT
6 6' x 6' Ballistic Barrier Blankets-Level III-A	\$2,480	\$14,880.00
1 Bullet Resistant Door for Court Lobby		5,755.00
1 Upgrade Cashiers Workstation		5,700.00
1 Fabric Task/Swivel Stool for Judge Clarino's Cashier		199.99
1 Mobile File Cabinet for Judge Clarino's Clerk		99.00
1 Computer Desk w/Storage		159.99
10 Paper Pro Generation II High Start (Desk Staplers)	33.95	<u>339.50</u>
Total		\$27,133.48



Armor UP L.P. dba

BulletProofME Body Armor

Bulletproof Vests, Plates, Helmets & Armor to
Put the Odds in YOUR favor

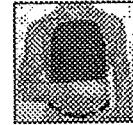

PRODUCT
CATALOG

- [HOME](#)
 - [PRODUCTS](#)
 - [WHY BulletProof ME?](#)
 - [ARMOR FAQs](#)
 - [BALLISTIC INFO PAGES](#)
 - [SATISFACTION GUARANTEE](#)
 - [CONTACT Bullet Proof ME](#)
 - [VEST SIZING](#)
 - [ORDER](#)
-

ProMAX Ballistic Blankets

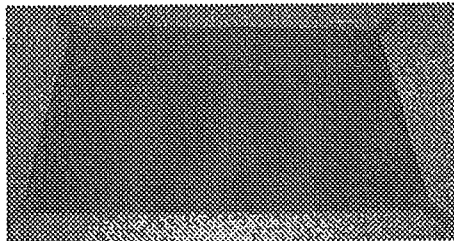

We have many years of experience helping customers with custom needs in cars, trucks, planes, helicopters, industrial plants, etc., etc. [Contact us](#) to discuss your unique needs.

Ballistic Barrier Blankets

- Available in ballistic protection [Level II](#) or [III-A](#)
- Level III-A Tested with the MIL-STD-662F for a 17 grain, .22 caliber Fragmentation FSP for a ballistic [V-50](#) of 1,975 fps (602 mps)
- Produced from multiple layers of Aramid fabric conforming to the protection level required, then sewn into a tough, abrasion-resistant and water-repellent nylon cover.
- Heavy-duty nylon web loop on the corners are standard, plus extra loops on long sides. We can substitute grommets for web loops if desired with a small additional cost.

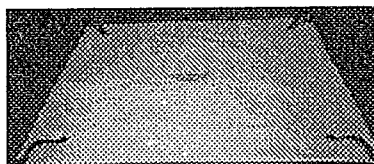

Outershell also available in flame-resistant, and water-repellent Avenue material in Black or Safety [YELLOW](#)

Made-to-order, and shipped in 3 to 6 weeks.

Size	Level II	Level III-A
~4' x 4' ~122 X 122 cm	\$ 1,080	\$ 1,150
~4' x 5' ~122 X 152 cm	1,350	1,420

Why BulletProofME?

- 1) [Personal service](#) on the phone. We care that you end up happy.
- 2) [Professional Level of Products and Service](#) years of experience you can trust
- 3) [Proper Fitting](#) is what makes the biggest difference in the real world. We are experts at Body Armor.
- 4) [Fast Shipping](#) We stock most products in popular sizes/colors.



"Bulletproof" Satisfaction GUARANTEE

13 Years of Making Customers Happy..

"some of the finest Body Armor that is available"
Chief Counsel, US Congress (Ret.)
[More letters and lives saved...](#)

Almost everything we sell is:



Made in the USA

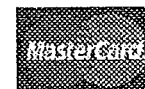

~4' x 6'	1,620	1,690
~122 X 183 cm		
~5' x 6'	2,020	2,080
~152 X 183 cm		
~6' x 6'	2,400	2,480
~183 X 183 cm		
Custom sizes available upon request	Email for Quote	Email for Quote
Rough Weight per Square Foot (Square footage times lbs. per Sq.Ft. = Total Blanket Weight)	~1.0	~1.5
<u>Cordura® Nylon Color Choices</u>		
Outershell also available in flame-resistant, and water-repellent Avenue material in Black or Safety YELLOW		

Call for quantity discounts for 10 or more, or discounts for prepayment via Bank Wire.

Related Pages:

[Tactical Ballistic Shields](#)

Put the odds in YOUR favor...

ORDER

[Complete Product LIST](#)

» CONTACT US «

ArmorUP L.P. dba BulletProofME Body Armor, 6705 Highway 290 West, Suite 502, Austin, Texas 78735

- Please call for an appointment before visiting -

This site © 1999 - 2013 Bullet Proof ME.com
[Copyright Notice](#) • [Legal Terms of Sale and Website Use](#)
 Bullet Photos © Winchester Ammunition

Ashcraft's Lock & Door

09/27/13

TOWN of Newburgh
Courts

Ⓐ 845-564-7161 x 204

Ⓑ 845-564-7171

Security metal Products

3'0" X 7'0" Bullet Resistant Labeled RH Flush
Door & Door frame Level 8 \$ 3,510.⁰⁰
Frame is welded

Full mortise Continuous Hinge \$ 375.⁰⁰
MARKAR HG305 83 1/8" US320

Cylindrical Lockset Grade 1 \$ 195.⁰⁰
YALE PB5405 LN US260

Door closer Grade 1 \$ 175.⁰⁰
SARGENT 281 P10 EN

\$ 4,255.⁰⁰

Labor to Install \$ 1,500.⁰⁰

ADD for wood door

\$ 1,800.⁰⁰

\$ 5,755.⁰⁰

GULLA WOODWORKING, INC.

6 Venice Road
Patterson, NY 12563
TEL (914) 522-8478
FAX (845) 278-1674

PROPOSAL AND ACCEPTANCE

000241

PROPOSAL SUBMITTED TO <u>TOWN JUSTICE COURT</u>		PHONE	DATE <u>9-25-13</u>
STREET <u>311 - Rt - 32</u>		JOB NAME	
CITY, STATE AND ZIP CODE <u>NEWBURGH N.Y. 12550</u>		JOB LOCATION	
ARCHITECT <u>ATT. FRAN</u>	DATE OF PLANS	JOB PHONE	

We hereby submit specifications and estimates for:

3" NEW DESK TOP - WITH LEGS TO MATCH EXISTING ONE -
NEW PENINSULA CAB - AS PER PLAN -
LAM COLOR TBD.
TAKE OUT OLD DESK + INSTALL NEW ONE

We Propose hereby to furnish material and labor — complete in accordance with above specifications, for the sum of:

FIVE THOUSAND SEVEN HUNDRED

dollars (\$ 5,700⁰⁰)

Payment to be made as follows:

All material is guaranteed to be as specified. All work to be completed in a workman-like manner according to standard practices. Any alteration or deviation from above specifications involving extra costs will be executed only upon written orders, and will become an extra charge over and above the estimate. All agreements contingent upon strikes, accidents or delays beyond our control. Owner to carry fire, tornado and other necessary insurance. Our workers are fully covered by Workmen's Compensation Insurance.

Authorized Signature

Note: This proposal may be withdrawn by us if not accepted within 30 days.

Acceptance of Proposal - The above prices, specifications and conditions are satisfactory and are hereby accepted. You are authorized to do the work as specified. Payment will be made as outlined above.

Signature

Signature

Date of Acceptance

* Same on both sides of island.

* laminate top

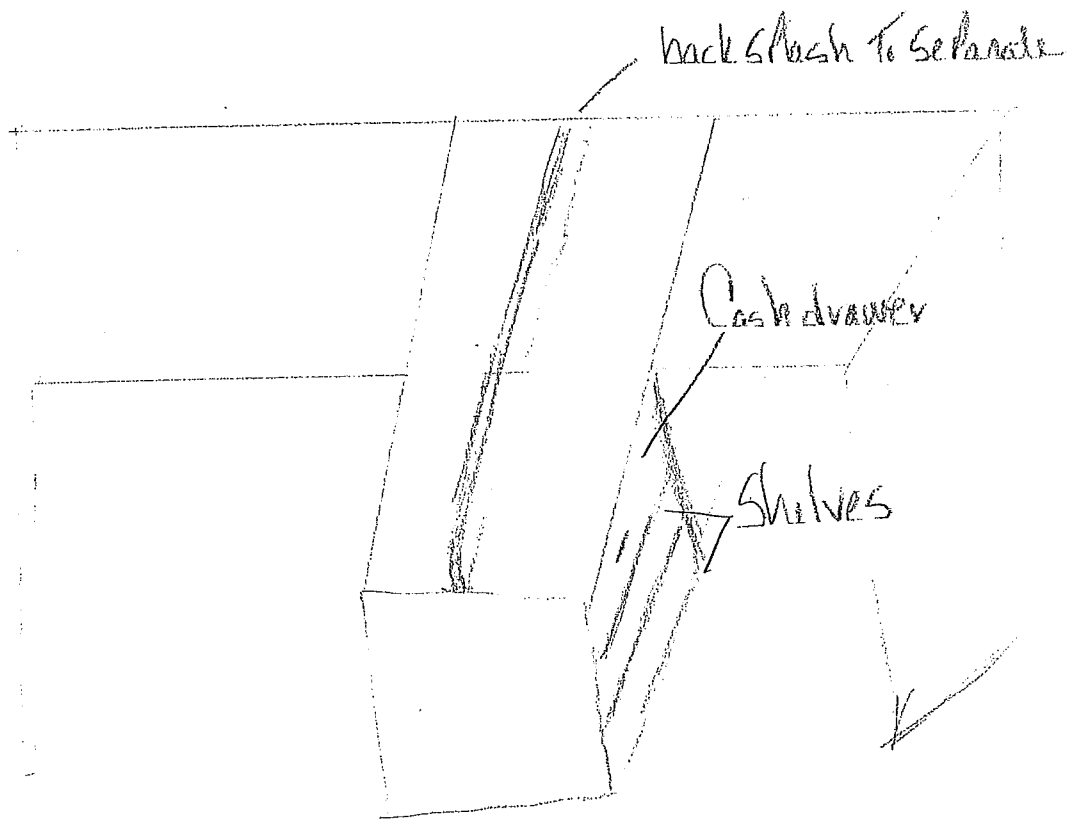



Favorites Lists | Easy Reorder | Order by Item #

My Account

Log in | (0 items)

Chairs & Stools

view larger

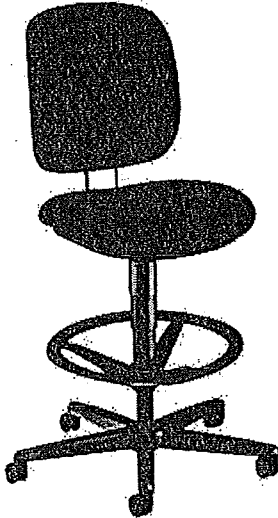

RC window



HON® Comfortask® Fabric Task/Swivel Stool, Black

Item: 505491 Model: H5905AB10T

Read 2 Reviews

Like

- Black 100% Olefin upholstery with Scotchgard® protection
 - Armless (Optional arms may be purchased separately)
 - Pneumatic seat height and back height adjustment
- See more details

FREE SHIPPING, plus 5% back for Rewards Members
 In Stock Online
 Expected Delivery: 7 - 14 Business Days
 FREE Shipping to store (Learn More)

SHARE:

Online Only

\$199.99
EACH

Customers Who Viewed This Also Viewed:

Select an Item

Qty. [Add to Cart](#)
[Add to Favorites](#)

- Product Info
- Reviews
- Q & A
- Supplies & Accessories

Product Details | Specifications | Adj. Back Height Video

Product Details

- Black 100% Olefin upholstery with Scotchgard® protection
- Armless (Optional arms may be purchased separately)

Specifications

- Strong lumbar support and over sized cushions
 - Pneumatic seat height adjustment is controlled by a button on the bottom of the seat, (See images)
 - Nylon base with dial wheel carpet casters
 - Dimensions: 39-5/8" - 49-3/4"H x 26-3/4"W x 30"D
 - Seat Size: 21-3/4" - 31-7/8"H x 20"W x 18"D
 - Back Size: 16-3/4"H x 16-1/4"W
 - Meets or exceeds ANSI/BIFMA standards
 - Weight rated up to 250 lb. based on an 8 hour work day
 - Ready to assemble
 - Mfr. limited lifetime warranty
- This product is only returnable if defective when received

Back dimensions	16-1/4"W x 16-3/4"
Assembly Required	Yes
Warranty	Lifetime limited
Seat color	Black
Base Material	Nylon
Meets ANSI/BIFMA standards	Yes
Seat to floor	21-3/4" - 31-7/8"H
Chair Type	Task
Rated level of use	8 hrs
Base Color	Black
Adjustable Headrest	No
Lumbar Support	Yes

Related Products



HON® Adjustable Swivel Task/Lab Stool Vinyl Healthcare Black,

HON Adjustable Swivel Task/Lab Stool Armless Design Black, Vinyl. Pneumatic seat height adjustment. Solid construction stands up ...



Lumisource Scooper Fiberglass Bar Stool, Black

Lumisource Scooper Bar stool constructed from chrome and fiberglass adds aesthetics and durability to the stool. Black colored ...



Safco 3434 Polyurethane Economy Lab Stool, Black

Black polyurethane upholstery Pneumatic seat height adjustment and 5" pneumatic lift to handle a variety of tasks Overall ...

Related Searches

pneumatic back swivel chair

armless comfortask chair

economy extended height chair

hon black nylon chair

safco economy lab stool

black mesh stool

This Web site is intended for use by US residents only. See International Sites. See our delivery policy for full details. Copyright 2012, Staples, Inc.. All Rights Reserved.

Questions? Call 1-800-333-3330 or email us.

Site Map | AdChoices

Close Window

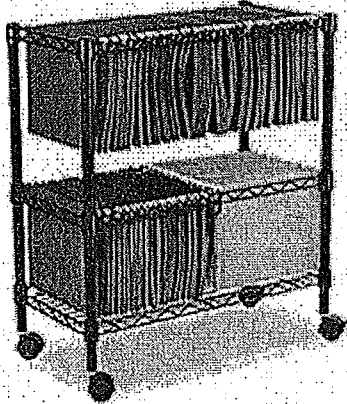

ALEFW601426BL

Mobile files help keep paper work handy when you need it and out of the way when you don't. Four 2" hooded casters, two locking. Bottom shelf adjusts in 1" increments and is rated at 250 lbs. Assembles without tools. Accommodates letter and legal size hanging files. Versatile front to back or side to side filing. Color: Black; Overall Width: 26"; Overall Depth: 14".

RC

Value Pack:	No
Ground Delivery:	Yes
Recycled:	No
Assembly Required:	Light Assembly Required
Manufacturers Warranty:	No Manufacturers Warranty
Green Product:	No
Country of Origin:	CN
Weight (pounds):	16.94 (lb.)
Retail Unit:	EA
MSRP:	\$99.00
Returnable Status:	This item IS returnable

Other Information:

Global Product Type	File Cabinets-Mobile File
Color	Black
Overall Width	26"

Overall Depth	14"
Overall Height	29 1/2"
Caster/Glide/Wheel	Four Casters, 2 Locking
Document Size Accommodation	Legal; Letter
Shelf Count	1
Compliance Standards	Meets or exceeds ANSI/BIFMA standards; NSF Certified
Pre-Consumer Recycled Content Percent	0%
Post-Consumer Recycled Content Percent	0%
Total Recycled Content Percent	0%
Special Features	Two-Tier File Unit

Close Window



[Favorites Lists](#) | [Easy Reorder](#) | [Order by Item #](#)

[My Account](#)

[Log in](#) | (0 items)

[Desks & Home / Computer Desks](#)



[view larger](#)

Felix



RTA Products Techni Mobili Computer Desk with Storage, Mahogany

Item: 125277 Model: RTA-3520-M615

[Read 3 Reviews](#)

Like

Mahogany finish with three storage drawers is made with heavy-duty engineered wood panels with a moisture...

30"H x 48"W x 23"D

Features a spacious elevated desktop above a pedestal with an open back accessory shelf and three utility...

[See more details](#)

SHARE:

FREE SHIPPING, plus 5% back for Rewards Members

FREE Shipping to store ([Learn More](#))

Online Only

\$159.99
Each

Customers Who Viewed This Also Viewed:

Currently Out of Stock

[Add to Favorites](#)

[Product Info](#)

[Reviews](#)

[Q & A](#)

[Supplies & Accessories](#)

Product Details

Product Details

This Techni Mobili Computer Desk with Storage boasts a simple yet elegant design

- Mahogany finish with three storage drawers is made with heavy-duty engineered wood panels with a moisture resistant PVC laminate veneer and a scratch-resistant powder-coated steel frame

RE: we need a price

Staplers

RE: we need a price

From: "Bob Hettinger" <valuoffice@csdsl.net>
 To: "Patricia Moore" <pmoore@nycourts.gov>
 Date: Thursday - August 29, 2013 11:28 AM
 Subject: RE: we need a price
 Attachments: Mime.822
 Ok.

From: Patricia Moore [mailto:pmoore@nycourts.gov]
Sent: Thursday, August 29, 2013 11:26 AM
To: valuoffice@csdsl.net
Subject: RE: we need a price

Bob
 They are going to wait until the end of the year. Thanks again!!!
 Patti
 >>> "Bob Hettinger" 08/28/13 2:53 PM >>>
 Ok?.

From: Patricia Moore [mailto:pmoore@nycourts.gov]
Sent: Wednesday, August 28, 2013 2:46 PM
To: valuoffice@csdsl.net
Subject: RE: we need a price

Thanks Bob we will let you know how many

Patti
 >>> "Bob Hettinger" 08/28/13 2:12 PM >>>
 Patti, On 5 would be \$ 35.95 each and on 10 would be \$ 33.95 each??.
 Thank you Bob

From: Patricia Moore [mailto:pmoore@nycourts.gov]
Sent: Wednesday, August 28, 2013 12:31 PM
To: valuoffice@csdsl.net
Subject: we need a price

hi Bob

We would like to order staplers.
 Paper Pro Generation II High Start
 # ACI- 1460
 We Need a price if we order 5
 and a price if we order 10

Thanks !!
 Patti

10. FLEET MAINTENANCE: Award of Bid for Accessory Storage

TOWN OF NEWBURGH
SUMMARY OF QUOTATION FORM

10-7-13

10

REQUESTED BY:

Jim LaColla

DATE PREPARED:

10/7/13

ITEM/SERVICE PURCHASED

ACCESSORY STORAGE SHELTER

VENDOR NAME

County Construction Erectors Du-Ben Steel Buildings

ORANGE LAKE CONST.

ADDRESS

527 UAPER AVE.

501 GARDNERTOWN RD

CITY/STATE/ZIP

NEWBURGH, NY 12550

NEWBURGH, NY 12550

PHONE #

564-1244

845-787-4496

CONTACT PERSON

ROBERT STONE

JOE RUCCIERO SR

PRICE QUOTED

16,708⁴²

\$16,000

EXPIRATION DATE

10/27/13

—

VENDOR CHOSEN

ORANGE LAKE CONSTRUCTION (PRICE INCLUDES 4" CONCRETE FLOOR)

*NOTE: If the vendor you wish to purchase from did not give the lowest quote, state reason why you did not purchase from the lowest cost vendor.

DEPARTMENT HEAD SIGNATURE



DATE:

10/7/13

(ATTACH ANY WRITTEN QUOTES, IF REQUIRED)

PROPOSAL

Page # _____ of _____ pages

ORANGE LAKE CONST. CORP.
501 GARDNERTOWN RD.
NEWBURGH, NY 12550

Proposal Submitted To: <i>TOWN OF NEWBURGH</i>	Job Name: <i>TIRE SHED</i>	Job #
Address: <i>GARDNERTOWN Rd</i>	Job Location: <i>FLEET MAINTANCE BLD</i>	
<i>NEWBURGH NY</i>	Date: <i>7-27-13</i>	Date of Plans
Phone #	Fax #	Architect

We hereby submit specifications and estimates for:

*12' x 43' x 12' High Single Slope 1" ON 12" PITCH
26 GA GALVALUME P.B.R. PANEL ROOF (SCREW DOWN)
(2) END WALL'S 26 GA P.B.R. PAINTED WALL PANEL'S
LOW END 11' 1st Bay 13' 2nd Bay 13' WITH PORTAL FRAME, 3rd
Bay 17'
INSTALL NEW STEEL DOOR 3'0" x 7'0" IN EXISTING BLD.*

*ALL PIER'S 12" SONOTUBES, 44" BELOW EXISTING
GARAGE FLOOR AND LEVEL WITH!*

\$5,000⁰⁰ DEPOSIT REQUIRED TO ORDER BLD

\$14,327⁵⁰

4" CONCRETE SLAB OVER 4" ITEM 4 COMPACTED WITH BROOM FINISH

IF NEEDED BOTH FOR \$16,000⁰⁰

\$2,400⁰⁰

We propose hereby to furnish material and labor — complete in accordance with the above specifications for the sum of:

\$ _____ Dollars

with payments to be made as follows: _____

Any alteration or deviation from above specifications involving extra costs will be executed only upon written order, and will become an extra charge over and above the estimate. All agreements contingent upon strikes, accidents, or delays beyond our control.

Respectfully
submitted

Note — this proposal may be withdrawn by us if not accepted within _____ days.

Acceptance of Proposal

The above prices, specifications and conditions are satisfactory and are hereby accepted. You are authorized to do the work as specified. Payments will be made as outlined above.

Signature _____

Date of Acceptance _____

Signature _____

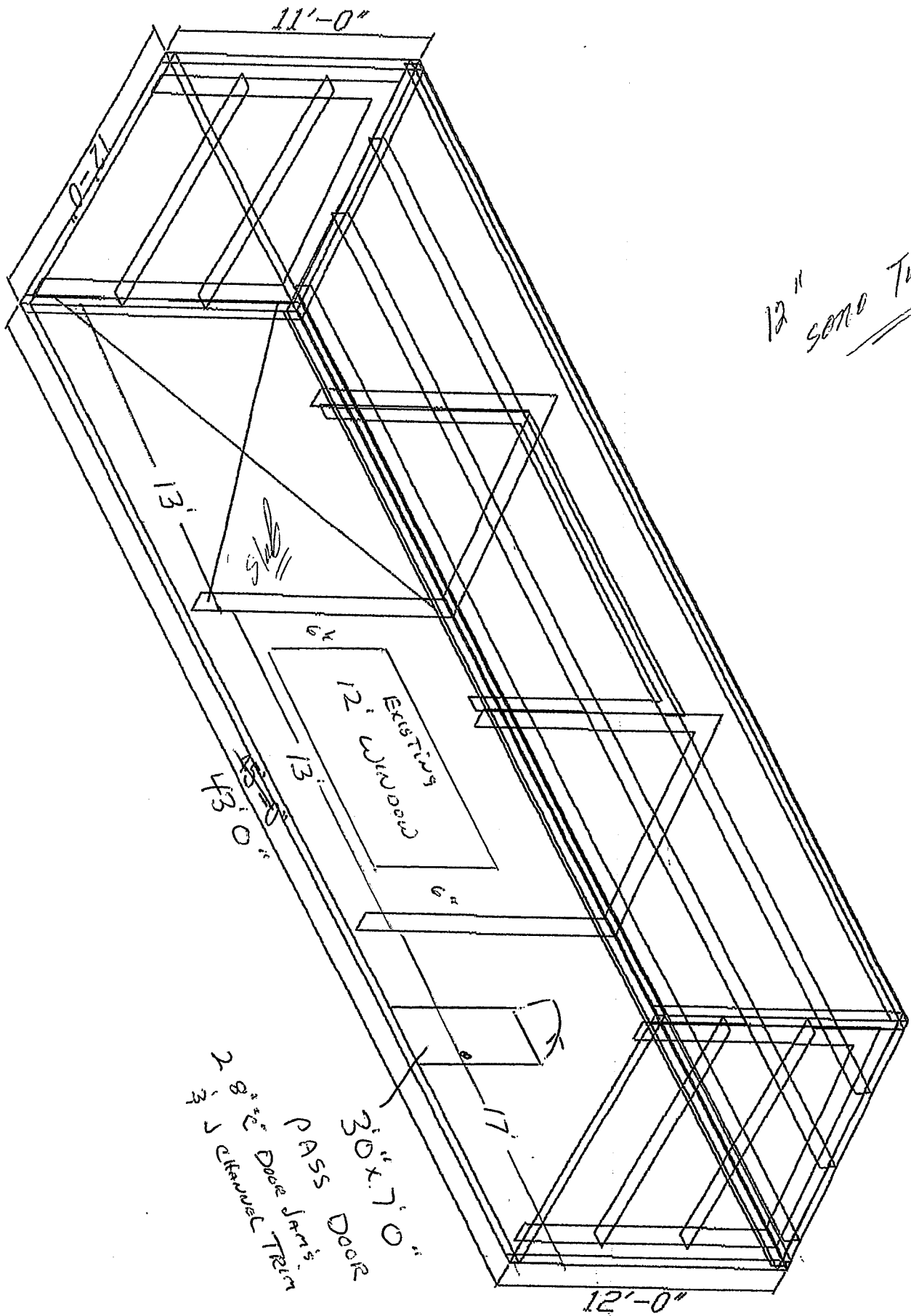

12" SCHED TUBES

30" x 7' 0" DOOR
 2 8" x 2" DOOR JAMB'S
 2 3/4" CHANNEL TRIM
 P.A.S.S.

GARDNERTOWN RD

DRIVE WAY TO HIGHWAY DEPT →

OFFICE

GARAGE

NEW STRUCTURE

12

43

TOWN OF NEWBURGH

FLEET MAINTENANCE

ACCESSORY STORAGE

The Town of Newburgh's ("Owner's") acceptance of the proposal submitted by Orange Lake Construction Corp. ("Contractor") is subject to the following requirements and conditions:

1. The Contractor shall assert no claim against the Owner on account of any variation between the estimated quantities and the actual quantities as measured when the work is complete, or on account of any mistake, misunderstanding or misconception as to the nature, location or amount of work to be performed by the Contractor under its accepted proposal.
2. The lump sum price or, as the case may be, the gross sum price on a unit price contract, shall include all the labor and materials required for the entire completion of the contract work by the Contractor. The Contractor acknowledges that the price as bid includes without limitation the restoration, to no less than their original condition existing streets, sidewalks, lawns, driveways, terraces, and all other areas disturbed or damaged by the Contractor during the performance of the contract work.
3. The Contractor shall employ local labor, insofar as the same may be reasonably available. Attention of the Contractor is called to the requirements and obligations relating to labor law requirements and prevailing wage rates.
4. The Contractor shall procure and deliver to the Town of Newburgh evidence of insurance in amounts not less than \$1,000,000 for each person and \$3,000,000 for each occurrence with coverage of all automotive equipment, endorsed to the Town of Newburgh as an additional named insured. The Contractor shall take out and maintain during the life of the Contract Workers' Compensation Insurance in conformity with the provisions of the Workers' Compensation Law of the State of New York, for all Contractor's employees engaged in work under this Contract required to be covered by law, and in case any such work is sublet, the Contractor shall require all subcontractors engaged in work under this Contract to provide similar statutory Workers' Compensation and Employer's Liability Insurance

5. The Contractor agrees that, in the event that persons or property of the Owner or of others sustain loss, damage or injury, including death, resulting from the intentional, reckless or negligent acts of the Contractor, or its Subcontractors, in their performance of this Contract, or from its or their failure to comply with any of the provisions of law, the Contractor shall indemnify and hold the Owner and its representatives harmless from all legal expenses and attorneys' fees incurred, all claims and judgment for damages, and all other costs by reason thereof.
6. The Contractor shall, at its own expense, provide all labor, materials, apparatus, scaffolding, appliances, utensils, tools, machinery, transportation and cartage and whatever else may be required of every description necessary to perform and complete the work, and shall be solely responsible for the same and for the safe, proper and lawful construction, maintenance and use thereof.
7. During performance and up to the date of acceptance by the Owner, the Contractor shall be under an absolute obligation to protect the unfinished work as well as materials and equipment against any damage, loss or injury; and, in the event of such damage, loss or injury, he shall promptly replace or repair such work
8. The rate of progress of the work shall be such that the entire work covered under NOTICE TO PROCEED shall be fully completed within 120 consecutive calendar days after issuance of the NOTICE TO PROCEED.
9. The Contractor warrants and represents that the work shall satisfy all the requirements of the bid solicitation; be completed free from fault and defects; be of the highest quality and incorporate only new materials and equipment unless the bid solicitation otherwise provided; be free of liens and encumbrances; be constructed in compliance with all applicable laws and insurance requirements; and be fit for the intended use and purpose.
10. The Owner may terminate the Contractor's right and obligation to perform all or any portion of the work, at any time and for any

reason whatsoever, with or without cause, upon written Notice of Termination to the Contractor. Such Notice of Termination shall specify the effective date of such termination and the extent to which performance of the work is terminated.

Following termination, the Owner shall pay the Contractor all unpaid balance due for work performed, less amounts retained and withheld. The Contractor waives any and all claims for damages relating to or arising out of such termination.

After the effective date of termination, the Owner may take all action necessary or desirable to complete the work, including entering into contracts with other contractors, with or without public bidding to the extent allowed by law.

11. The Contractor shall not assign, transfer or convey the agreement or any of its right, title or interest herein without the express prior consent in writing of the Owner.
12. The Contractor's acceptance of final payment shall be construed as the Contractor's complete, unconditional and general release of the Owner by the Contractor (and all persons claiming by, through and/or under the Contractor) relating to all claims for loss and damage relating to, or arising out of the bid acceptance or the work, except for the Contractor's claim for amounts still withheld.

Acknowledged and
Agreed by:

Contractor: Orange Lake Construction Corp.

By: 
Signature

Printed Name: Joe Puggiello

Title: Pres

Date: 10-7-13