

SU-30 - SINGLE UNIT TRUCK

SU-30 - SINGLE UNIT TRUCK

OVERALL LENGTH	30.000 FT
OVERALL WIDTH	8.000 FT
OVERALL BODY HEIGHT	13.500 FT
MIN BODY GROUND CLEARANCE	1.367 FT
TRACK WIDTH	8.000 FT
LOCK-TO-LOCK TIME	5.00 s
MAX STEERING ANGLE (VIRTUAL)	31.80°

Z:\PROJECTS\2024\12\18\2024\12\18\TRUCK TURNING EXHIBIT.DWG

ISSUE	DATE	BY	DESCRIPTION
1	12/18/2024	JF	ISSUED FOR REVIEW

NOT APPROVED FOR CONSTRUCTION

STONEFIELD
engineering & design

Rutherford, NJ · New York, NY · Boston, MA
Princeton, NJ · Tampa, FL · Detroit, MI
www.stonefielddesign.com

584 Broadway, Suite 310, New York, NY 10012
Phone 718.606.8305

TRUCK TURN EXHIBIT

**CAPITAL GROWTH
BUCHALTER**

PROPOSED QUICKCHEK

SECTION 86, BLOCK 1, LOT 39.3
2 LAKESIDE ROAD
TOWN OF NEWBURGH
ORANGE COUNTY, NEW YORK

ZACHARY E. CHAPLIN, P.E.
NEW YORK LICENSE No. 99748
LICENSED PROFESSIONAL ENGINEER

STONEFIELD
engineering & design

SCALE: 1"=20' PROJECT ID: NYC-230182.01

TITLE:
**SU-30 TRUCK
TURNING EXHIBIT**

DRAWING:

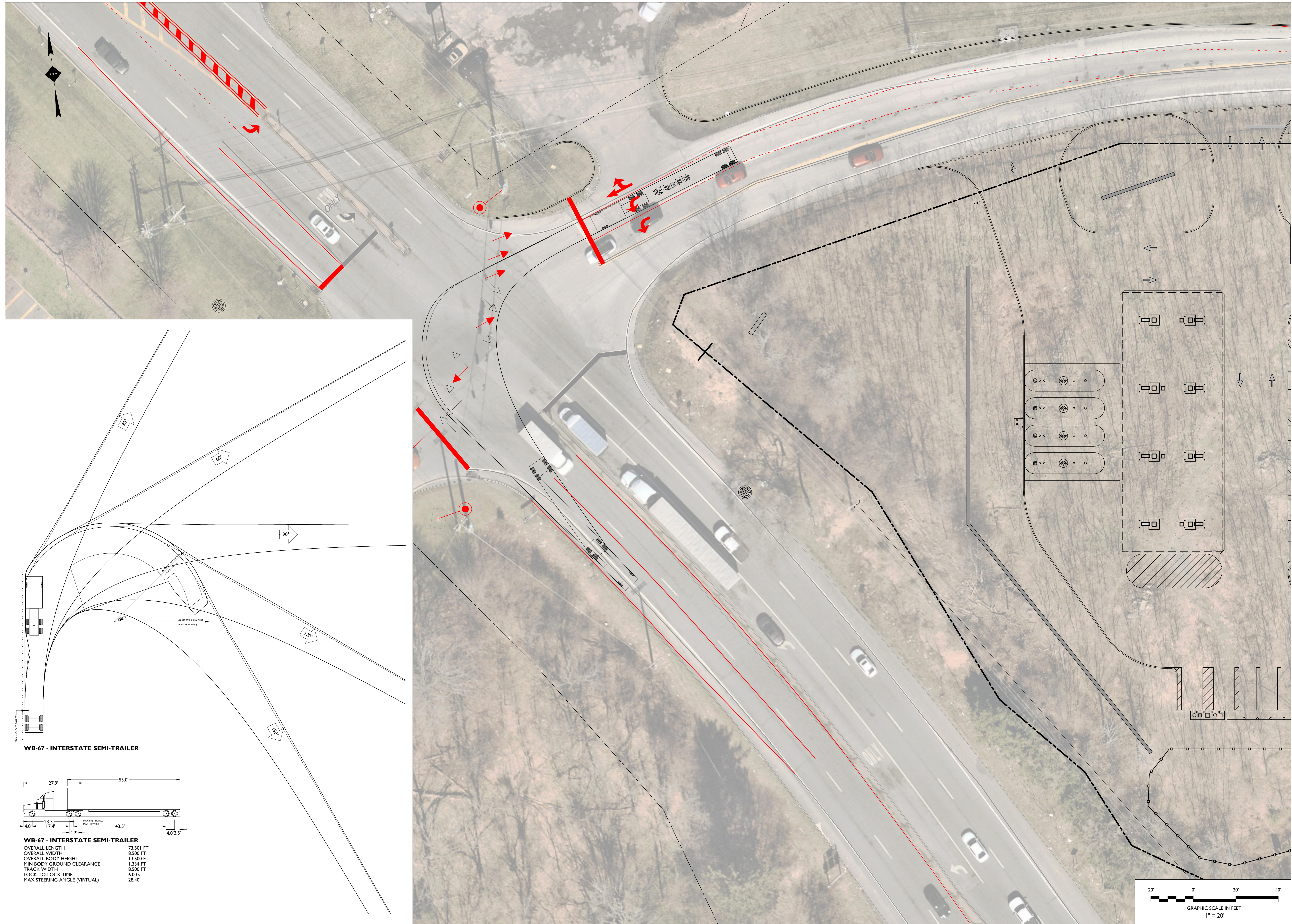

WB-67 - INTERSTATE SEMI-TRAILER

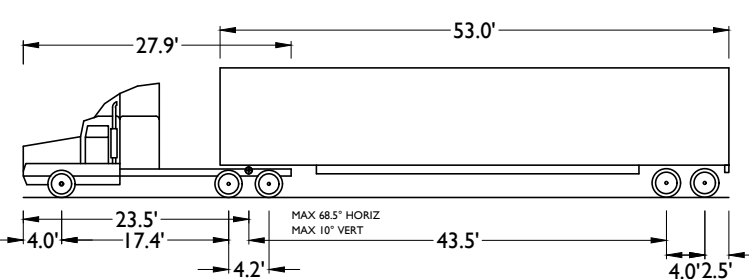

WB-67 - INTERSTATE SEMI-TRAILER

OVERALL LENGTH	73.501 FT
OVERALL WIDTH	8.500 FT
OVERALL BODY HEIGHT	13.500 FT
MIN BODY GROUND CLEARANCE	1.334 FT
TRACK WIDTH	8.500 FT
LOCK-TO-LOCK TIME	6.00 s
MAX STEERING ANGLE (VIRTUAL)	28.40°

ISSUE	DATE	BY	DESCRIPTION
1	12/18/2024	JF	ISSUED FOR REVIEW

NOT APPROVED FOR CONSTRUCTION

STONEFIELD
engineering & design

Rutherford, NJ · New York, NY · Boston, MA
Princeton, NJ · Tampa, FL · Detroit, MI
www.stonefielddesign.com

584 Broadway, Suite 310, New York, NY 10012
Phone 718.606.8305

TRUCK TURN EXHIBIT

**CAPITAL GROWTH
BUCHALTER**

PROPOSED QUICKCHECK

SECTION 86, BLOCK 1, LOT 39.3
2 LAKESIDE ROAD
TOWN OF NEWBURGH
ORANGE COUNTY, NEW YORK

ZACHARY E. CHAPLIN, P.E.
NEW YORK LICENSE No. 99748
LICENSED PROFESSIONAL ENGINEER

STONEFIELD
engineering & design

SCALE: 1"=20' PROJECT ID: NYC-230182.01

TITLE:
**WB-67 TRUCK
TURNING EXHIBIT**

DRAWING:
2 OF 4

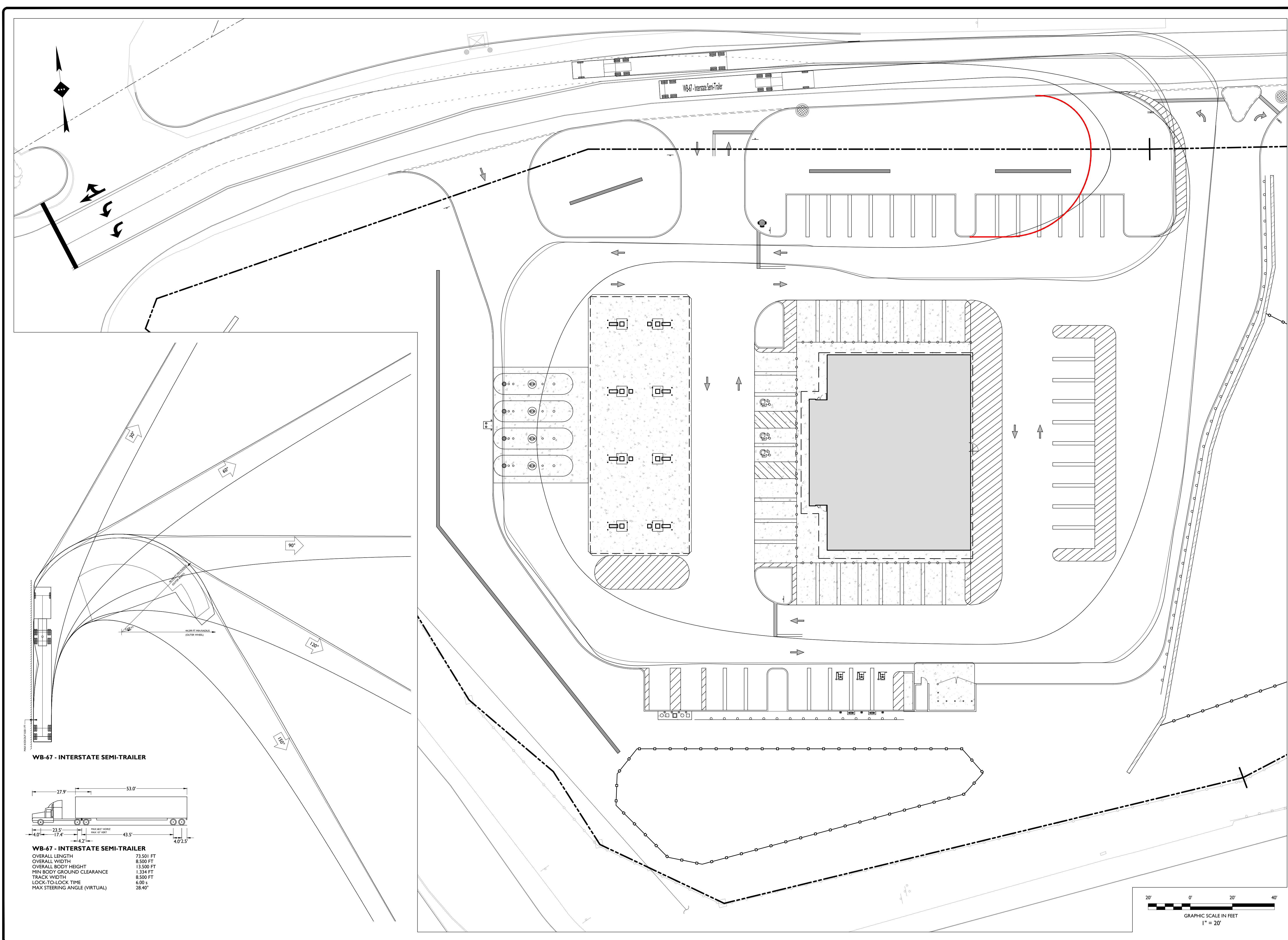

WB-67 - INTERSTATE SEMI-TRAILER

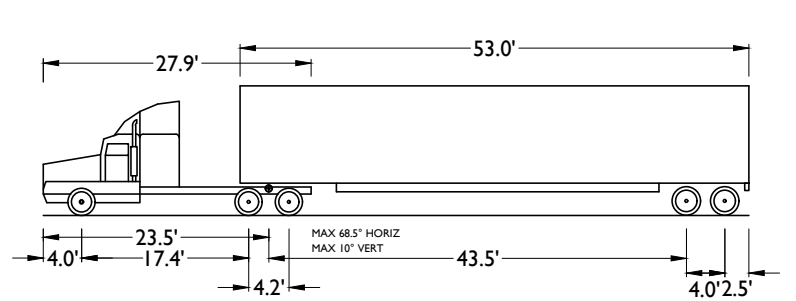

WB-67 - INTERSTATE SEMI-TRAILER

OVERALL LENGTH	73.501 FT
OVERALL WIDTH	8.500 FT
OVERALL BODY HEIGHT	13.500 FT
MIN BODY GROUND CLEARANCE	1.334 FT
TRACK WIDTH	8.500 FT
LOCK-TO-LOCK TIME	6.00 s
MAX STEERING ANGLE (VIRTUAL)	28.40°

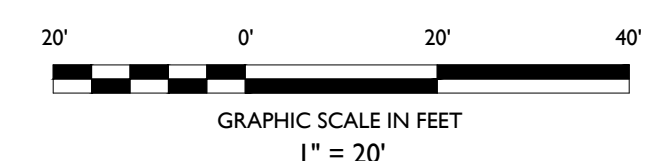

ISSUE	DATE	BY	DESCRIPTION
1	12/18/2024	JF	ISSUED FOR REVIEW

NOT APPROVED FOR CONSTRUCTION

STONEFIELD
engineering & design

Rutherford, NJ · New York, NY · Boston, MA
Princeton, NJ · Tampa, FL · Detroit, MI
www.stonefielddesign.com

584 Broadway, Suite 310, New York, NY 10012
Phone 718.606.8305

TRUCK TURN EXHIBIT

**CAPITAL GROWTH
BUCHALTER**

PROPOSED QUICKCHECK

SECTION 86, BLOCK 1, LOT 39.3
2 LAKESIDE ROAD
TOWN OF NEWBURGH
ORANGE COUNTY, NEW YORK

ZACHARY E. CHAPLIN, P.E.
NEW YORK LICENSE No. 99748
LICENSED PROFESSIONAL ENGINEER

STONEFIELD
engineering & design

SCALE: 1"=20' PROJECT ID: NYC-230182.01

TITLE:
**WB-67 TRUCK
TURNING EXHIBIT**

DRAWING:
3 OF 4

DRAWING PREPARED BY CAPITAL GROWTH BUCHALTER - LAKESIDE ROAD, NEWBURGH, NY 10973. TRUCK TURN EXHIBIT DWG

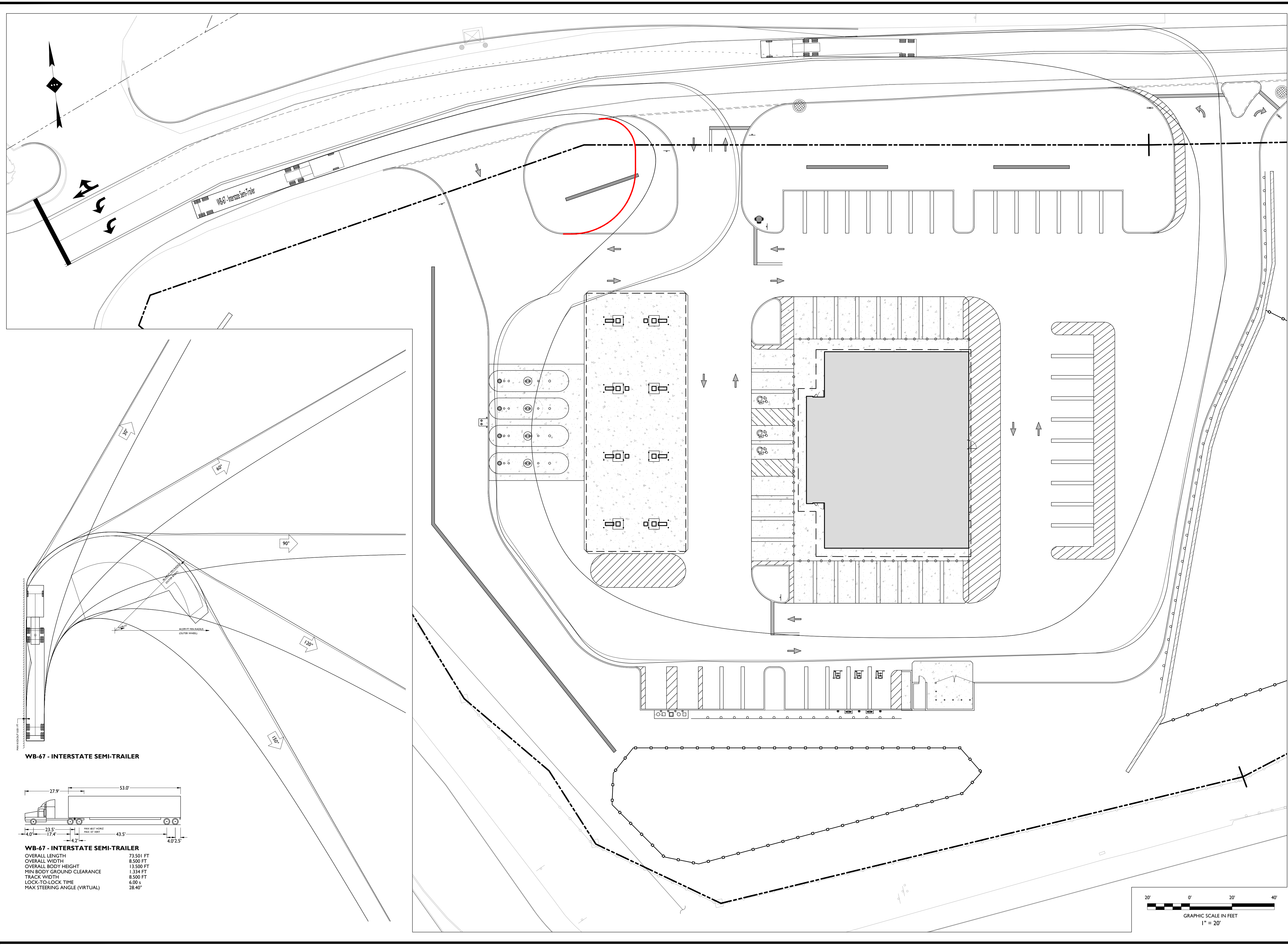

WB-67 - INTERSTATE SEMI-TRAILER

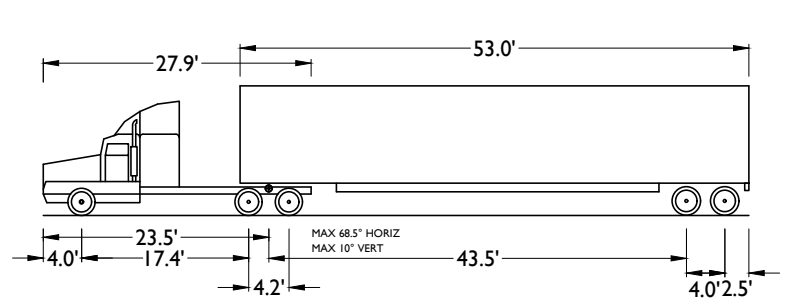

WB-67 - INTERSTATE SEMI-TRAILER

OVERALL LENGTH	73.501 FT
OVERALL WIDTH	8.500 FT
OVERALL BODY HEIGHT	13.500 FT
MIN BODY GROUND CLEARANCE	1.334 FT
TRACK WIDTH	8.500 FT
LOCK-TO-LOCK TIME	6.00 s
MAX STEERING ANGLE (VIRTUAL)	28.40°

ISSUE	DATE	BY	DESCRIPTION
1	12/18/2024	JF	ISSUED FOR REVIEW

NOT APPROVED FOR CONSTRUCTION

STONEFIELD
engineering & design

Rutherford, NJ · New York, NY · Boston, MA
Princeton, NJ · Tampa, FL · Detroit, MI
www.stonefielddesign.com

584 Broadway, Suite 310, New York, NY 10012
Phone 718.606.8305

TRUCK TURN EXHIBIT

**CAPITAL GROWTH
BUCHALTER**

PROPOSED QUICKCHECK

SECTION 86, BLOCK 1, LOT 39.3
2 LAKESIDE ROAD
TOWN OF NEWBURGH
ORANGE COUNTY, NEW YORK

ZACHARY E. CHAPLIN, P.E.
NEW YORK LICENSE No. 99748
LICENSED PROFESSIONAL ENGINEER

STONEFIELD
engineering & design

SCALE: 1"=20' PROJECT ID: NYC-230182.01

TITLE:
**WB-67 TRUCK
TURNING EXHIBIT**

DRAWING:
4 OF 4

DRAWING PREPARED BY: CAPITAL GROWTH BUCHALTER - LAKESIDE ROAD, NEWBURGH, NY 10973; TRUCK TURN EXHIBIT DWG